

DP200 BT & RJ telecom surge protection devices



Lightning surge protection for modems and telemetry equipment connected to Public Switched Telephone Networks

- ◆ Protects fax, modems, telemetry and other telecom equipment
- ◆ Robust - 10kA surge capability
- ◆ BT or RJ11 style plug and socket
- ◆ Simple installation
- ◆ Full 4-wire protection
- ◆ Immune to power crossing
- ◆ RFI version available for noisy environments



The DP200 BT & RJ series safeguard modems, telemetry outstations and fax machines from induced surges and transient overvoltages caused by lightning and other electrical disturbances. A single lightning strike can easily destroy unprotected equipment and lead to expensive down-time.

Telecom authorities now encourage the end user to fit secondary protection for their equipment. Telecom providers may supply some simple surge protection such as a gas discharge tube at the customers' premises. However, this is generally only to protect the telephone line itself and offers little or no protection for any equipment attached to it.

Hybrid surge protection circuitry is utilised within the DP200/BT & DP200/RJ to provide the best protection devices currently available. Should mains voltages be applied to the telecom line, for example by falling cables, the DP200 BT or RJ unit's power crossing immunity prevents damage to both the telecom equipment and the protection device.

The DP200 BT & RJ devices are easy to install. Simply loosen the lid retaining screw, remove the lid and screw to a wall or panel. The unit should be earthed with 2.5mm² cable. This cable is screwed into the unit's earth terminal and the other end is connected to the earth of the protected equipment.

The DP200/BT/RFI & DP200/RJ/RFI provide RFI filtering in addition to protection from lightning induced overvoltages. These devices suppress interference due to medium wave radio transmissions, and other sources, which can compromise normal telecom operation.

Complete protection can be achieved using Telematic's range of ac power surge protection devices to prevent surges entering equipment via their power supply. The MA05 and MA10 range combine a high level of protection with the benefit of RFI filtering thus removing noise and other unwanted signals from the supply.

Surge protection – the facts

Many kinds of process control instrumentation and communication networks can be destroyed by surges (also referred to as "transient over-voltages") on power, signal and telecommunication lines. This invariably results in expensive downtime. Surges may be caused by lightning, heavy electrical load switching, electrical faults or electrical 'noise', from arc welding and other industrial sources. Those induced by lightning are on the increase globally, and it is recognised by European and other international standards that lightning can induce voltage surges of more than 10kV on equipment cables - and a 'near miss' can inject more than 5kA of current through electronic circuitry.

The only effective way of preventing such damage is to equip all vulnerable connections with surge protection devices (SPDs). These incorporate circuitry designed to divert surges safely to earth, and to control the voltage seen by sensitive equipment. The Telematic range includes SPDs for virtually all applications, including mains power supplies, process instrumentation, PSTN installations and computer networking, thus providing 'all-round' protection from one source. These products are available directly from Telematic and from distributors around the world. Further information on all aspects of surge protection can be found in Telematic's range of Technical Application Notes available by post or downloaded from our Web Site.

A member of The MTL Instruments Group plc



INSTALLATION

In order to mount and earth the unit, the DP200 BT or RJ must first be opened by loosening the lid retaining screw and removing the lid. The unit should be connected to a good earth point for optimum protection. This point should be at the mains distribution board if the telecomms cable runs close by, otherwise at the mains supply earth close to the protected equipment.

Connection to this earth point should be made using 2.5mm² wire and should be kept to ≤1 metre. If multiple lines are required, the earths should not be 'daisy-chained'; each SPD should be earthed separately. Figure 1 shows a complete installation with protection for both ac power and telecom SPDs fitted. The earth is taken from the supply to the telemetry equipment using a short link (≤1m).

The two fixing holes can accommodate either No.6 or No.8 wood screws or up to 3mm diameter bolts. The operation of the DP200 BT or RJ is unaffected by its orientation, although it should not be mounted on a damp surface. Once the earthing and mounting operations are complete, the DP200 BT or RJ is simply re-assembled by fitting the lid back onto the base and tightening the lid retaining screw. A comprehensive installation guide is supplied with each unit.

SPECIFICATIONS

(all figures typical at 25°C unless otherwise stated)

Maximum discharge current

10kA (8/20μs)

Primary protector rating

10kV (10/700μs)

Working voltage

162V

Max. continuous operating voltage

175V

Leakage current

10μA at working voltage

Ringer Equivalence Number (REN)

0

Casing

Plastic ABS - VO IP50 Rated

Ambient temperature limits

-40°C to +70°C (working and storage)

Humidity

5% to 95% RH (non-condensing)

Weight

125g nominal

APPROVALS

Model	Authority	Certificate
DP200/BT	BABT	608379
DP200/BT/RFI	BABT	608379

Telematic Limited

Pondwicks Road, Luton, Beds, UK LU1 3LH
 Telephone: +44 (0)1582 429464 Fax: +44 (0)1582 459669
 E-mail: enquiry@telematic.com Web site: http://www.telematic.com

A member of The MTL Instruments Group plc

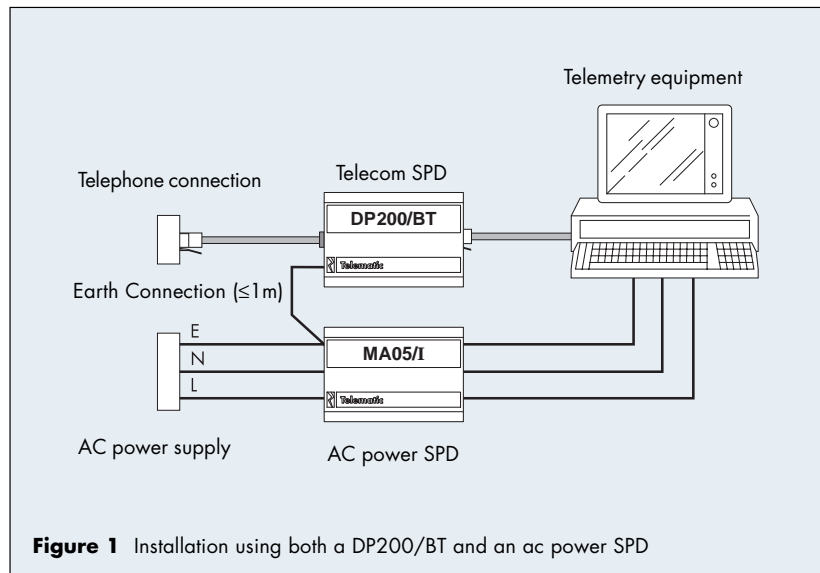

Figure 1 Installation using both a DP200/BT and an ac power SPD

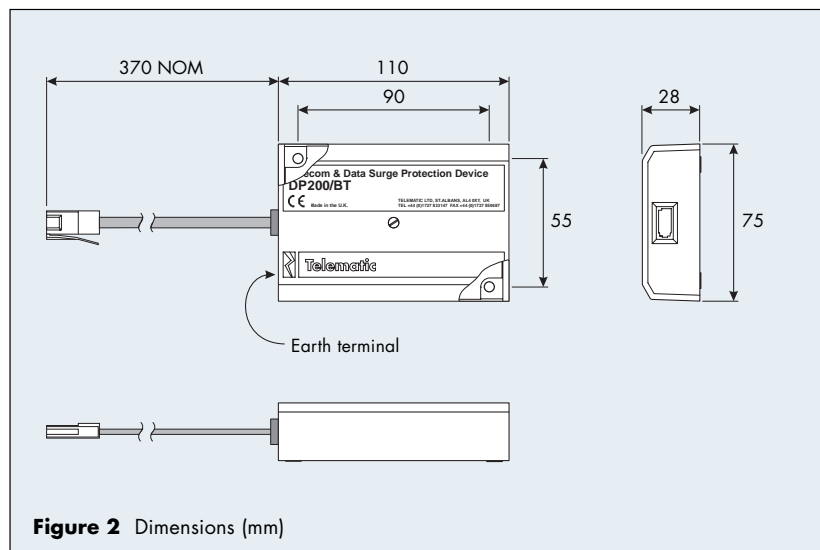

Figure 2 Dimensions (mm)

Typical values	DP200/BT & DP200/RJ	DP200/BT/RFI & DP200/RJ/RFI
Line resistance	5 ohms	10 ohms maximum
Limiting voltage 6kV/3kA 5kV/125A	375V 205V	250V 205V
Bandwidth (600 ohms)	6MHz	43kHz
Max stopband attenuation		65dB
Capacitance line to line line to earth	<200pF <150pF	<1.5nF <150pF
Insertion loss at 300Hz at 3400Hz	0.06dB 0.12dB	0.06dB 0dB
Line balance 300-3400Hz	better than 46dB	better than 46dB