



WE CATCH THE
BEST TECH. FOREVER

EVERBOUQUET INTERNATIONAL CO., LTD.

PART NO. : MC1602M-SR

FOR MESSRS. : _____

CONTENTS

<i>NO.</i>	<i>ITEM</i>	<i>PAGE</i>
1.	COVER	1
2.	RECORD OF REVISION	2
3.	GENERAL SPECIFICATION	3
4.	MECHANICAL DATA	3
5.	ABSOLUTE MAXIMUM RATINGS	4
6.	ELECTRICAL CHARACTERISTICS	5
7.	OPTICAL CHARACTERISTICS	5
8.	OUTLINE DIMENSION	6
9.	BLOCK DIAGRAM	7
10.	POWER SUPPLY	7

ACCEPTED BY : _____

PROPOSED BY : _____



RECORD OF REVISION

DATE	PAGE	SUMMARY

3. General specifications

3.1 General specifications

PLEASE REFER TO:

“CUSTOMER ACCEPTANCE STANDARD SPECIFICATIONS (MS-10-12780)”.

3.2 This individual specification is prior to general specifications

4. Mechanical data

- (1) NUMBER OF CHARACTERS-----16 CH * 2 LINE
- (2) MODULE SIZE-----85.0 W * 32.6 H * 10.0 T (Max) mm
- (3) EFFECTIVE AREA -----64.5 W * 16.0 H mm
- (4) CHARACTER PATTERN-----5 * 7 DOTS + CURSOR
- (5) CHARACTER SIZE -----2.96 W * 4.86 H mm
- (6) CHARACTER PITCH-----3.55 mm
- (7) DOT SIZE -----0.56 W * 0.66 H mm
- (8) DOT PITCH-----0.60 W * 0.70 H mm
- (9) VIEWING DIRECTION-----6 O’CLOCK

5. Absolute maximum ratings

5.1 Electrical absolute maximum ratings

<i>I T E M</i>	<i>SYMBOL</i>	<i>MIN.</i>	<i>MAX.</i>	<i>UNIT</i>	<i>COMMENT</i>
POWER SUPPLY FOR LOGIC	V _{DD} -V _{SS}	0	6.0	V	-----
INPUT VOLTAGE	V _I	V _{SS}	V _{DD}	V	-----
STATIC ELECTRICITY	-----	-----	100	V	NOTE (1)

NOTE (1): ELECTRO-STATIC DISCHARGE RESISTANCE IS TESTED BY CHARGING A 200PF CAPACITOR AND DISCHARGING IT BY CONTACT WITH A INTERFACE CONNECTOR PIN.

5.2 Environmental absolute maximum ratings

<i>I T E M</i>	<i>OPERATING</i>		<i>STORAGE</i>		<i>COMMENT</i>
	<i>MIN.</i>	<i>MAX.</i>	<i>MIN.</i>	<i>MAX.</i>	
AMBIENT TEMPERATURE	0°C	50°C	-20°C	70°C	-----
HUMIDITY	NOTE (2)		NOTE (2)		NO CONDENSATION
VIBRATION NOTE (3)	-----	0.5G	-----	2G	10~300Hz XYZ DIRECTIONS 1 Hr EACH
SHOCK NOTE (3)	-----	3G	-----	50G	10 msec XYZ DIRECTIONS 1 TIME EACH
CORROSIVE GAS	NOT ACCEPTABLE		NOT ACCEPTABLE		

NOTE (2) : $T_a \leq 50^\circ\text{C}$: 90%RH MAX.

$T_a > 50^\circ\text{C}$: ABSOLUTE HUMIDITY MUST BE LOWER THAN THE HUMIDITY OF 90% RH AT 50°C. (80% RH AT 60°C)

NOTE (3): 1G = 9.8 m/s²

6. Electrical characteristics

$T_a = 25^\circ\text{C}$ $V_{DD} = 5.0 \pm 0.25 \text{ V}$

<i>I T E M</i>	<i>SYMBOL</i>	<i>CONDITION</i>	<i>MIN.</i>	<i>TYP.</i>	<i>MAX.</i>	<i>UNIT</i>	
INPUT VOLTAGE	V_{IH}	-----	2.2	-----	V_{DD}	V	
	V_{IL}		V_{SS}	-----	0.6	V	
OUTPUT VOLTAGE (H LEVEL)	V_{OH}	$I_{OH} = -0.2 \text{ mA}$	2.4	-----	-----	V	
	V_{OL}	$I_{OL} = 1.2 \text{ mA}$	-----	-----	0.4	V	
POWER SUPPLY CURRENT	I_{DD}	$V_{DD} = 5.0\text{V}$	-----	1.0	1.5	mA	
RECOMMENDED LCD DRIVING VOLTAGE	$V_{DD}-V_o$	DUTY= 1/16 $\Phi = 10^\circ$ $\theta = 0^\circ$	$T_a = 0^\circ\text{C}$	-----	4.9	-----	V
			$T_a = 25^\circ\text{C}$	-----	4.5	-----	V
			$T_a = 50^\circ\text{C}$	-----	4.1	-----	V

NOTE (1): RECOMMENDED LCD DRIVING VOLTAGE MAY FLUCTUATE ABOUT $\pm 0.5\text{V}$ BY EACH MODULE.

7. Optical characteristics

$T_a = 25^\circ\text{C}$ $V_{DD} = 5.0\text{V}$

<i>I T E M</i>	<i>SYMBOL</i>	<i>CONDITION</i>	<i>MIN.</i>	<i>TYP.</i>	<i>MAX.</i>	<i>UNIT</i>	<i>NOTE</i>
VIEWING ANGLE	$\Phi 2-\Phi 1$	$K = 2.0$	30	40	-----	deg.	2
CONTRAST RATIO	K	$\Phi = 10^\circ$ $\theta = 0^\circ$	3.0	4.0	-----	-----	2
RESPONSE TIME	tr (rise)	$\Phi = 10^\circ$ $\theta = 0^\circ$	-----	200	350	ms	2
	tf (fall)	$\Phi = 10^\circ$ $\theta = 0^\circ$	-----	300	400	ms	2

NOTE (2): SEE CUSTOMER ACCEPTANCE STANDARD SPECIFICATION FOR DEFINITION OF OPTICAL CHARACTERISTICS.

9. Block diagram

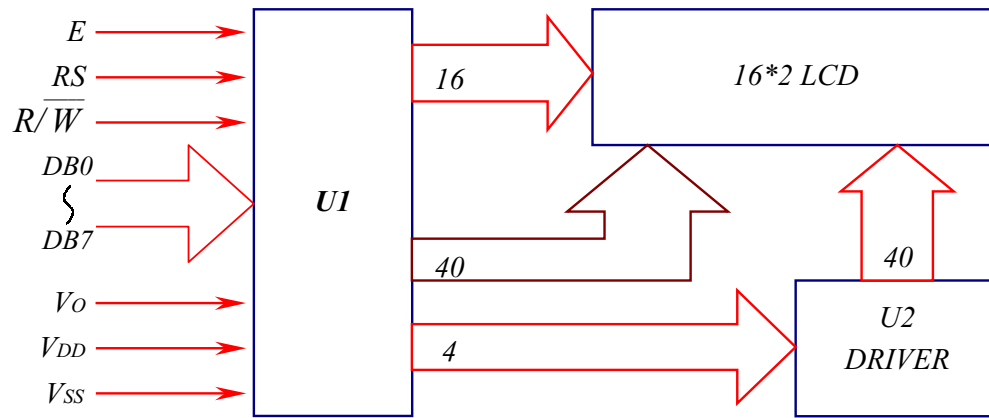

Character	1	2	3	4	5	6	7	8	9	10	11	12	13	14	15	16
LINE 1	00	01	02	03	04	05	06	07	08	09	0A	0B	0C	0D	0E	0F
LINE 2	40	41	42	43	44	45	46	47	48	49	4A	4B	4C	4D	4E	4F

10. Power supply for LCM

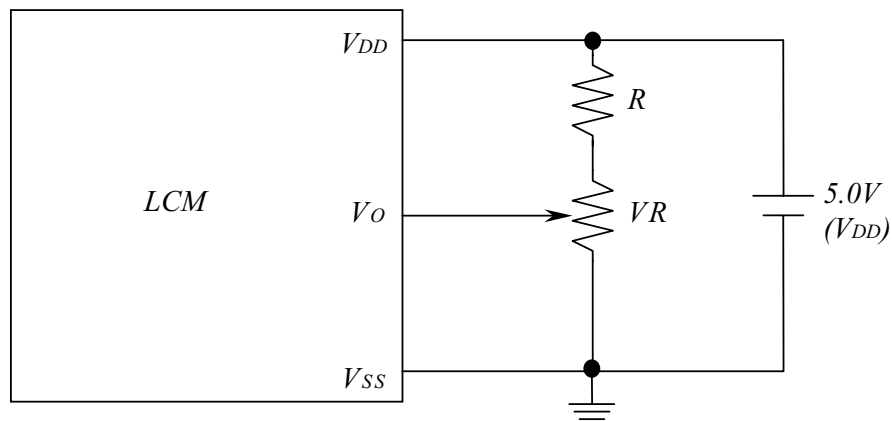

RECOMMENDED RESISTOR R: $V_{DD} - V_O \geq 1.5V$

$V_{DD} - V_O$: LCD DRIVING VOLTAGE

VR: $10K\Omega \sim 20K\Omega$