



EVERBOUQUET INTERNATIONAL CO., LTD.

WE CATCH THE
BEST TECH. FOREVER

PART NO. : MC1602C8-SERIES

FOR MESSRS. : _____

CONTENTS

<i>NO.</i>	<i>ITEM</i>	<i>PAGE</i>
1.	COVER	1
2.	RECORD OF REVERSION	2
3.	GENERAL SPECIFICATION	3
4.	MECHANICAL DATA	4
5.	ABSOLUTE MAXIMUM RATINGS	5
6.	ELECTRICAL CHARACTERISTICS	6
7.	OPTICAL CHARACTERISTICS	7
8.	OUTLINE DIMENSION	8
9.	BLOCK DIAGRAM	9
10.	POWER SUPPLY FOR LCM	10



ACCEPTED BY: _____

PROPOSED BY : _____

RECORD OF REVISION

DATE	PAGE	SUMMARY

3. General specifications

3.1 General specifications

PLEASE REFER TO:

“CUSTOMER ACCEPTANCE STANDARD SPECIFICATIONS (MS-10-0069)”

3.2 This individual specification is prior to general specifications

3.3 NUMBERING SYSTEM

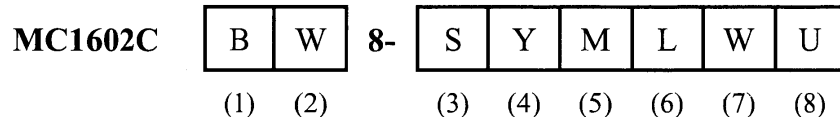

(1). CHARACTER FONTS :

PLEASE REFER TO

“CUSTOMER ACCEPTANCE STANDARD SPECIFICATIONS (MS-10-0069)”

(2). LCM TEMPERATURE :

“nil” : NORMAL TEMP

“W” : WIDE TEMP

(3). LCD TYPE :

“T” : TN TYPE

“S” : STN TYPE

“H” : HTN TYPE

“F” : FSTN TYPE

(4). LCD COLOR :

“Y” : YELLOW-GREEN

“B” : BLUE(STN/NEGATIVE)/BLACK(FSTN/NEGATIVE)

“G” : GRAY

“W” : WHITE(FSTN/POSITIVE)

(5). LCD POLARIZE TYPE

“nil” : TRANFLECTIVE

“M” : TRANSMISSIVE

(6). BACKLIGHT TYPE :

“L” : LED BACKLIGHT

(7). BACKLIGHT COLOR :

LED TYPE :

“nil” : YELLOW-GREEN

“A” : AMBER

“B” : BLUE

“G” : PURE-GREEN

“O” : ORANGE

“R” : RED

“W” : WHITE

(8). VIEWING DIRECTION :

“nil” : 6 O’CLOCK

“3” : 3 O’CLOCK

“U” : 12 O’CLOCK

“9” : 9 O’CLOCK

4. Mechanical data

- (1) NUMBER OF DOT -----16 CH * 2 LINE
- (2) MODULE SIZE -----80.0 W *36.0 H * 10.0 T(max) mm
- (3) EFFECTIVE AREA -----64.5 W * 16.0 H mm
- (4) CHARACTER PATTERN -----5 * 7 DOTS + CURSOR
- (5) CHARACTER SIZE-----2.96W * 4.86 H mm
- (6) CHARACTER PITCH -----3.55 mm
- (7) DOT SIZE-----0.56 W * 0.66 H mm
- (8) DOT PITCH -----0.60W * 0.70H mm

5. Absolute maximum ratings

5.1 Electrical absolute maximum ratings

<i>I T E M</i>	<i>SYMBOL</i>	<i>MIN.</i>	<i>MAX.</i>	<i>UNIT</i>	<i>COMMENT</i>
POWER SUPPLY FOR LOGIC	V _{DD} -V _{SS}	0	6.0	V	-----
INPUT VOLTAGE	V _I	V _{SS}	V _{DD}	V	-----
STATIC ELECTRICITY	-----	-----	100	V	NOTE (1)
POWER SUPPLY FOR LED	V _{LED}	-----	NOTE(2)	V	-----

NOTE (1): ELECTRO-STATIC DISCHARGE RESISTANCE IS TESTED BY CHARGING A 200PF CAPACITOR AND DISCHARGING IT BY CONTACT WITH A INTERFACE CONNECTOR PIN.

NOTE (2):

<i>SYMBOL</i>	<i>V_{LED} MAX.</i>	<i>LED TYPE</i>
V _{LED}	5.5V	YELLOW-GREEN,AMBER,ORANGE,RED
	5.0V	BLUE,PURE GREEN,WHITE

5.2 Environmental absolute maximum ratings

<i>I T E M</i>	<i>CONDITION</i>	<i>OPERATING</i>		<i>STORAGE</i>		<i>COMMENT</i>
		<i>MIN.</i>	<i>MAX.</i>	<i>MIN.</i>	<i>MAX.</i>	
AMBIENT TEMPERATURE	NORMAL	0 °C	50 °C	-20 °C	70 °C	-----
	WIDE	-20 °C	70 °C			
HUMIDITY	-----	NOTE (2)		NOTE (2)		NO CONDENSATION
VIBRATION NOTE (3)	-----	-----	0.5G	-----	2G	10~300Hz XYZ DIRECTIONS 1 Hr EACH
SHOCK NOTE (3)	-----	-----	3G	-----	50G	10 msec XYZ DIRECTIONS 1 TIME EACH
CORROSIVE GAS	-----	NOT ACCEPTABLE		NOT ACCEPTABLE		-----

NOTE (2): Ta ≤ 50 °C: 90% RH MAX.

Ta > 50 °C: ABSOLUTE HUMIDITY MUST BE LOWER THAN THE HUMIDITY OF 90% RH AT 50 °C. (80%RH AT 60 °C)

NOTE (3): 1G = 9.8 m/s²

6. Electrical characteristics

$T_a = 25\text{ }^\circ\text{C}$ $V_{DD} = 5.0 \pm 0.25\text{ V}$

<i>I T E M</i>	<i>SYMBOL</i>	<i>CONDITION</i>	<i>MIN.</i>	<i>TYP.</i>	<i>MAX.</i>	<i>UNIT</i>	
INPUT VOLTAGE	V _{IH}	-----	2.2	-----	-----	V	
	V _{IL}	-----	-----	-----	0.6	V	
OUTPUT VOLTAGE	V _{OH}	-I _{OH} = 0.205 mA	2.4	-----	-----	V	
	V _{OL}	I _{OL} = 1.2 mA	-----	-----	0.4	V	
POWER SUPPLY CURRENT	I _{DD}	V _{DD} = 5.0V	-----	1.0	1.5	mA	
RECOMMENDED LCD DRIVING VOLTAGE, NOTE(1)	V _{DD} -V _O	STN/ FSTN DUTY =1/16 Φ=10° NOTE(2)	Ta=-20°C	-----	4.8	-----	V
			Ta= 0°C	-----	4.7	-----	V
			Ta= 25°C	-----	4.5	-----	V
			Ta= 50°C	-----	4.3	-----	V
			Ta= 70°C	-----	4.2	-----	V
		TN DUTY =1/16 Φ=25° NOTE(2)	Ta=-20°C	-----	4.7	-----	V
			Ta= 0°C	-----	4.6	-----	V
			Ta= 25°C	-----	4.2	-----	V
			Ta= 50°C	-----	3.8	-----	V
			Ta= 70°C	-----	3.7	-----	V
POWER SUPPLY CURRENT FOR NOTE(3)	I _{LED}	V _{DD} = 5.0 V	-----	30	40	mA	

NOTE (1): RECOMMENDED LCD DRIVING VOLTAGE MAY FLUCTUATE ABOUT ±0.5V BY EACH MODULE.

(2): θ = 0° : VIEWING ANGLE AT 6 O’CLOCK
 θ = 180° : VIEWING ANGLE AT 12 O’CLOCK

(3): LED CURRENT OF DEFFERENT LED TYPE

<i>LED B.L TYPE</i>	<i>V_{LED}</i>	<i>I_{LED}</i>				<i>LED COLOR</i>
		<i>MIN.</i>	<i>TYP.</i>	<i>MAX.</i>	<i>UNIT.</i>	
A	4.8V	-----	30	40	mA	YELLOW-GREEN · AMBER · ORANGE · RED
B	4.0V	-----	30	40	mA	BLUE · WHITE · PURE GREEN

7. Optical characteristics

TN TYPE LCD

$$T_a = 25\text{ }^{\circ}\text{C} \quad V_{DD}-V_O = 4.2\text{V}$$

ITEM	SYMBOL	CONDITION	MIN.	TYP.	MAX.	UNIT	NOTE
VIEWING ANGLE	$\Phi 2-\Phi 1$	K = 1.4 NOTE(1)	20	30	----	deg.	NOTE(2)
CONTRAST RATIO	K	$\Phi = 25^{\circ}$ NOTE(1)	2.0	3.0	----	----	NOTE(2)
RESPONSE TIME	tr (rise)	$\Phi = 25^{\circ}$ NOTE(1)	----	150	250	ms	NOTE(2)
	tf (fall)	$\Phi = 25^{\circ}$ NOTE(1)	----	150	250	ms	NOTE(2)

STN TYPE LCD

$$T_a = 25\text{ }^{\circ}\text{C} \quad V_{DD}-V_O = 4.5\text{V}$$

ITEM	SYMBOL	CONDITION	MIN.	TYP.	MAX.	UNIT	NOTE
VIEWING ANGLE	$\Phi 2-\Phi 1$	K = 2.0 NOTE(1)	30	40	----	deg.	NOTE(2)
CONTRAST RATIO	K	$\Phi = 10^{\circ}$ NOTE(1)	3.0	4.0	----	----	NOTE(2)
RESPONSE TIME	tr (rise)	$\Phi = 10^{\circ}$ NOTE(1)	----	200	350	ms	NOTE(2)
	tf (fall)	$\Phi = 10^{\circ}$ NOTE(1)	----	300	400	ms	NOTE(2)

FSTN TYPE LCD

$$T_a = 25\text{ }^{\circ}\text{C} \quad V_{DD}-V_O = 4.5\text{V}$$

ITEM	SYMBOL	CONDITION	MIN.	TYP.	MAX.	UNIT	NOTE
VIEWING ANGLE	$\Phi 2-\Phi 1$	K = 2.0 NOTE(1)	30	40	----	deg.	NOTE(2)
CONTRAST RATIO	K	$\Phi = 10^{\circ}$ NOTE(1)	4.0	5.0	----	----	NOTE(2)
RESPONSE TIME	tr (rise)	$\Phi = 10^{\circ}$ NOTE(1)	----	200	350	ms	NOTE(2)
	tf (fall)	$\Phi = 10^{\circ}$ NOTE(1)	----	300	400	ms	NOTE(2)

Brightness for LED backlight

SYMBOL	CONDITION	MIN.	TYP.	MAX.	UNIT	LED TYPE	NOTE
B	$\Phi = 0^{\circ}$	4.0	----	----	cd/m ²	YELLOW-GREEN · RED · AMBER · ORANGE	NOTE(2)
	$\theta = 0^{\circ}$	6.0	----	----		BLUE · GREEN · WHITE	NOTE(3)

NOTE (1): $\theta = 0^{\circ}$ WHEN VIEWING ANGLE AT 6 O'CLOCK

$\theta = 180^{\circ}$ WHEN VIEWING ANGLE AT 12 O'CLOCK

(2): SEE CUSTOMER ACCEPTANCE STANDARD SPECIFICATION FOR DEFINITION OF OPTICAL CHARACTERISTICS.

(3): UNDER NORMAL TEMPERATURE AND HUMIDITY IN A DARK ROOM.

8. Outline dimension

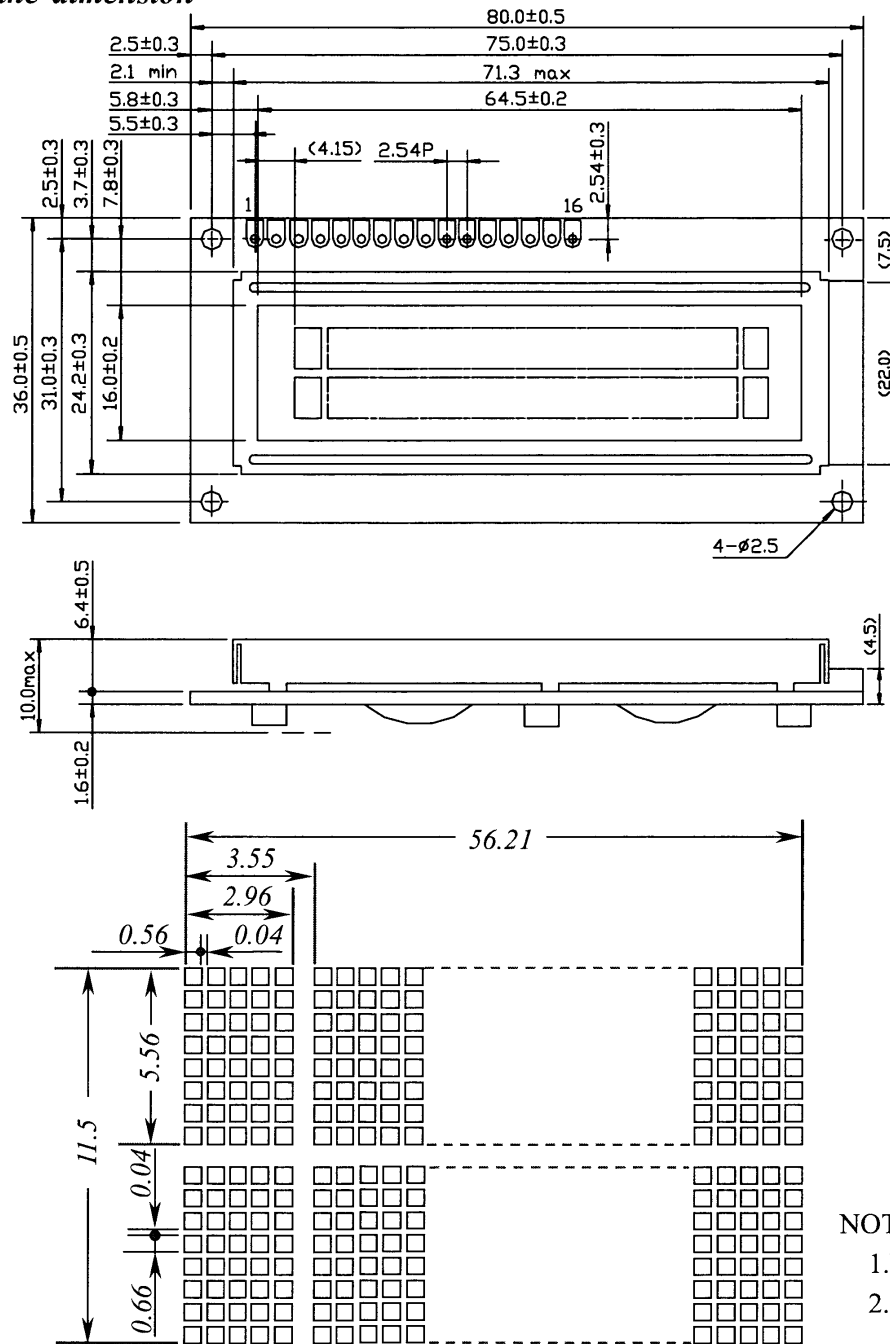

NOTE :
 1.UNIT : mm
 2.SCALE : NTS

Interface pin connection

PIN NO.	1	2	3	4	5	6	7	8
SYMBOL	V _{SS}	V _{DD}	V _O	RS	R/W	E	DB0	DB1
PIN NO.	9	10	11	12	13	14	15	16
SYMBOL	DB2	DB3	DB4	DB5	DB6	DB7	V _{LED(+)}	V _{LED(-)}

9. Block diagram

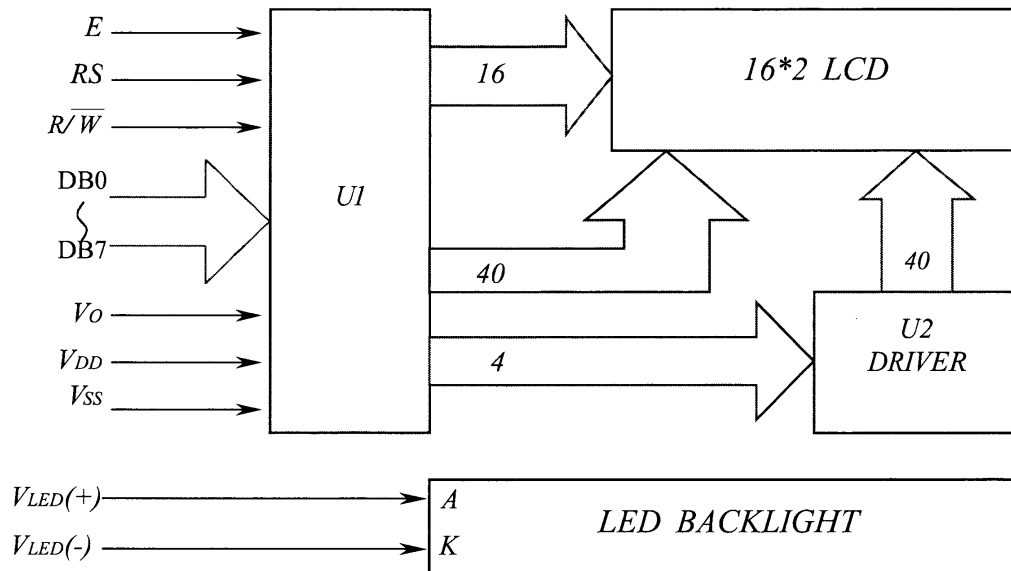

Display data address charts

Character	1	2	3	4	5	6	7	8	9	10	11	12	13	14	15	16
LINE 1	80	81	82	83	84	85	86	87	88	89	8A	8B	8C	8D	8E	8F
LINE 2	C0	C1	C2	C3	C4	C5	C6	C7	C8	C9	CA	CB	CC	CD	CE	CF

10. Power supply for LCM

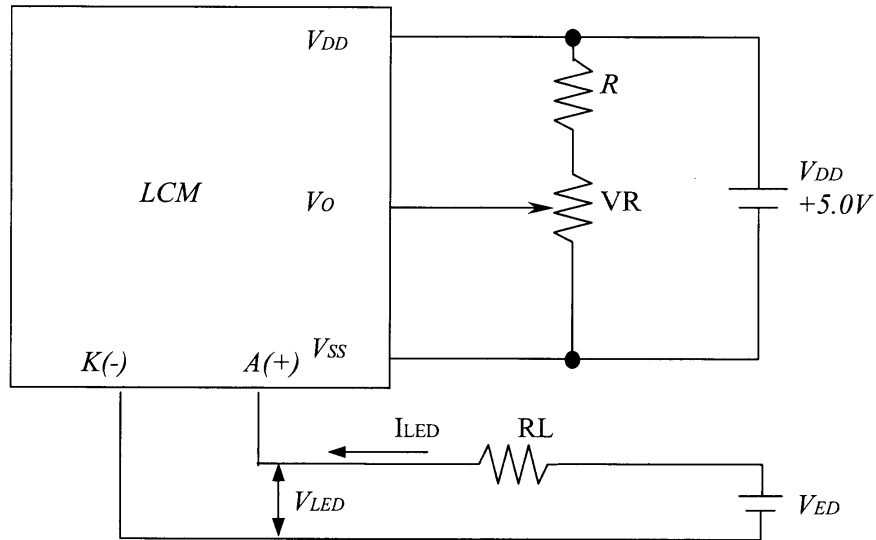

RECOMMENDED RESISTOR R : $V_{DD}-V_o \geq 1.5V$

$V_{DD}-V_o$: LCD DRIVING VOLTAGE

VR: $10K\Omega \sim 20K\Omega$

ITEM	LED TYPE	CONDITION
Limit resistor of LED (RL)	A	$RL \geq ((V_{ED}-5.0V) / I_{LED})$, $I_{LED} \leq 40mA$
	B	$RL \geq ((V_{ED}-4.0V) / I_{LED})$, $I_{LED} \leq 40mA$