

LENSES

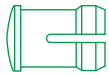

10mm THREADED LENS for PCB MOUNTED LEDs



U.S. & Foreign Patents Issued and Pending

VERSATILITY

CLIPLITE® lenses provide a method of viewing PCB mounted LEDs on a display panel. Designed to accommodate either HI-flux or 10mm LEDs. Permits LED viewing angles of up to 180 degrees. Lenses are available in six colors.

BRIGHTNESS

CLIPLITE® lenses enhance the direct viewing of PCB mounted LEDs. Mono, multi-color, infrared, and photo detection devices can be displayed in this manner. LED brightness levels can range from 20 to 40,000mcd.

APPLICATION

CLIPLITE® lenses permit the panel display of PCB mounted LED without its physical attachment to front panel. Properly installed, the assembly exceeds NEMA 4 for water, ice and dust conditions. Additionally tested for U.V., solar, temperature cycling, shock and vibration. Also provides circuit protection from ESD.

INSTALLATION

CLIPLITE® 10mm lenses are easily installed. Simply slip lens through a 9/16" panel opening, slide lock washer onto lens barrel and twist retaining ring. PCB mounted LED can then slide in and out of the lens without physical attachment to display panel. If overtightened, retaining ring is designed to slip back into previous thread. Secure by retightening ring.

SPECIFICATIONS

MATERIAL	Lens - Polycarbonate Lock washer - FH Steel, Nickel plate Retaining ring - Thermoplastic U.L. 94 V0 Rated Seal - EPDM
DESIGN	10mm low profile lens with fresnel rings.
MOUNTING	Mounts through front of panel. Retaining ring secures the assembly to panel. HMC 461 & HMS 462 mounts through a 9/16" (14.3mm) hole on 3/4" centers. Panel thickness 1/32" to 3/16".
TEST DATA	Assembly tested for: Temperature cycle -40°C to +105°C, Water, Ice, Shock/vibration up to 6g at 2000Hz, Solar & UV. Tests conducted by Consolidated Laboratories.

EASY THREE STEP PANEL ASSEMBLY

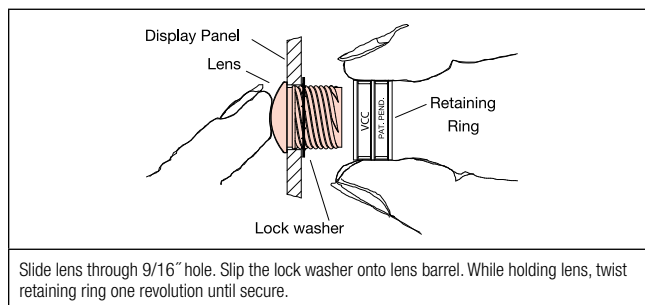

ORDERING CODES

HMC 461 RTP

MODEL

HMC 461 Standard Threaded 10mm Fresnel Lens
 HMS 462 Water Tight Threaded 10mm Fresnel Lens

HMC 461 ASSEMBLY CONTAINS

Lens
 Lock washer
 Retaining ring

HMS 462 ASSEMBLY CONTAINS

Lens w/Seal (exceeds NEMA 4)
 Lock washer
 Retaining ring

COLOR

RTP Red Transparent
 ATP Amber Transparent
 GTP Green Transparent
 BTP Blue Transparent
 YTP Yellow Transparent
 CTP Clear Transparent

LENS ASSEMBLY WITH PCB MOUNTED LEDs

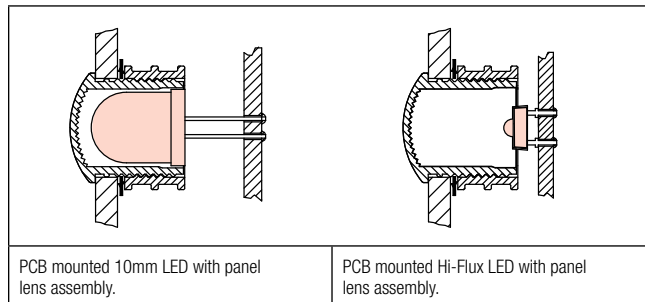

OUTLINE DRAWING

