

## FT3 SERIES TRI-LENSES for LUXEON™ LEDs: LUXEON I, III, and V, STAR and EMITTER

- High efficiency
- Available in 3 different beams
- 50mm diameter, sized for MR16 lamp applications
- Patent Pending

The FT3 series Tri-lens are available for both Batwing and Lambertian Luxeon™ LEDs from Lumileds (1).

A software-optimized aspheric profile combined with front shaped micro-lens arrays enable the generation of three different lens models: narrow beam, medium beam, and wide beam (2).

The high collection efficiency reaches 85% of the total flux emitted from the LED.

These lenses are assembled with a 50mm diameter holder. The holder assures the proper relative placement of the lens and the Luxeon™ LEDs. Heat staking the three legs of the holder to the customer's PCB or heat sink provides excellent optical and mechanical assembly (see Fraen Application Note FAN01-EN, at [www.fraen.com](http://www.fraen.com)).

Typical applications are:

- Reading lamps
- Signs
- Architectural Lighting
- Street Lights
- Most application where uniformity and high intensity over a wide angle is required

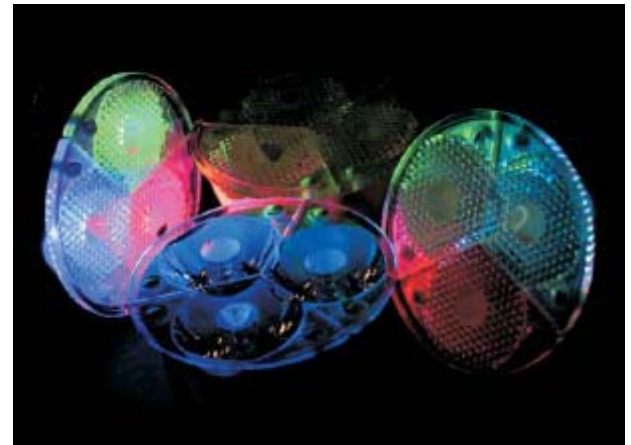

- (1) LUXEON™ is a trademark of Lumileds Lighting, LLC. For technical specification on LEDs please refer to the LUXEON™ datasheet or visit <http://www.luxeon.com> or [www.lumileds.com](http://www.lumileds.com)
- (2) Typical beam divergence may change with different color LEDs.

**FRAEN CORPORATION**  
80 Newcrossing Road  
Reading MA 01867  
Phone: 781.205.5300  
Fax: 781.942.2426

**FRAEN Srl**  
Via E.Fermi, 7  
20090 Cusago (MI) – Italy  
Phone: +39 02.90.39.40.49  
Fax: +39 02.90.39.37.36

Email: [optics@fraen.com](mailto:optics@fraen.com)  
Website: [www.fraensrl.com](http://www.fraensrl.com)

Distributed by Future Electronics



**Americas: 1-888-LUXEON2**  
[askluxeon@FutureElectronics.com](mailto:askluxeon@FutureElectronics.com)  
**Europe: 00-0800-44FUTURE**  
[luxeon.europe@FutureElectronics.com](mailto:luxeon.europe@FutureElectronics.com)  
**Asia: 1-800-LUMILEDS**  
[lumileds.asia@FutureElectronics.com](mailto:lumileds.asia@FutureElectronics.com)

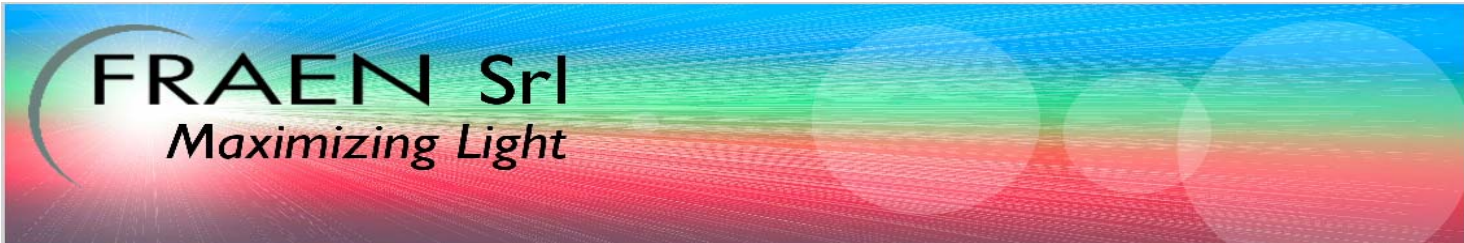





## General Characteristics



---

Lens Material	Optical Grade PMMA
Holder Material	PC ABS or Transparent PC
Operating Temperature range	-40deg C / + 80 deg C
Storage Temperature range	-40deg C / + 80 deg C

Average transmittance in visible spectrum (400 – 700nm) >90%, as measured using 3mm thick Optical Grade PMMA.

## Optical Characteristics: Total Beam Divergence

<u>With Batwing</u> LED		Typical total beam divergence (deg) (3)			
Lens Part Number	Type of lens	Red, Amber LEDs 	Blue, Cyan, Green LEDs 	White LEDs 	Warm White LEDs 
FT3-HNB1-Lbyy-H	Narrow beam	6	8	8	10
FT3-HMB1-Lbyy-H	Medium beam	25	25	25	30
FT3-HWB1-Lbyy-H	Wide beam	45	45	45	45

<u>With Lambertian</u> LED		Typical total beam divergence (deg) (3)		
Lens Part Number	Type of lens	Red, Orange, Amber LEDs 	Blue, Cyan, Green LEDs 	White LEDs 
FT3-HNB1-Lbyy-H	Narrow beam	8	10	10
FT3-HMB1-Lbyy-H	Medium beam	25	28	30
FT3-HWB1-Lbyy-H	Wide beam	40	45	45

- (3) The typical divergence varies with LED color due to different chip size and chip position tolerance.  
The typical total divergence is the full angle measured where the luminous intensity is half of the peak value.

## Optical Characteristics: On-axis efficiency

<u>With Batwing LEDs</u>		Typical on-axis efficiency (cd/lm) (4)(5)						
Lens Part Number	Type of lens	Blue LEDs	Cyan LEDs	Green LEDs	Yellow LEDs	Red LEDs	White LEDs	Warm White LEDs
FT3-HNB1-Lbyy-H	Narrow beam	28.3	29.5	29.5	32.6	32.6	28.4	13.5
FT3-HMB1-Lbyy-H	Medium beam	5.6	5.7	5.7	4.2	4.2	5.7	4.1
FT3-HWB1-Lbyy-H	Wide beam	1.6	1.7	1.7	1.3	1.3	1.6	1.6

<u>With Lambertian LEDs</u>		Typical on-axis efficiency (cd/lm) (4)(5)						
Lens Part Number	Type of lens	Blue LEDs	Cyan LEDs	Green LEDs	Yellow LEDs	Orange LEDs	Red LEDs	White LEDs
FT3-HNB1-Lbyy-H	Narrow beam	17	18.2	18.2	16.5	16.5	16.5	17.1
FT3-HMB1-Lbyy-H	Medium beam	5.3	5.5	5.5	4.4	4.4	4.4	5.6
FT3-HWB1-Lbyy-H	Wide beam	1.6	1.7	1.7	1.2	1.2	1.2	1.8

(4) The efficiency values listed below are the total values for the whole Tri-lens module. To estimate the on-axis intensity, multiply the on-axis efficiency of the lens (cd/lm) by the total flux of the Luxeon LED used. For more detail on flux binning please check the Luxeon LED datasheet at <http://www.luxeon.com>.

(5) Luminous intensity depends on the LEDs flux binning and LEDs tolerances. Please refer to the Luxeon datasheet for more details on flux binning and mechanical tolerances.

Typical illuminance measured in lux per lumen (**E**) is given by  $E=I/d^2$ , where (**I**) is the above on axis efficiency in cd/lm and (**d**) the distance between the light output and the measured point.

To estimate the total illuminance in lux, multiply the typical illuminance **E** by the flux in lumen of the LEDs used.



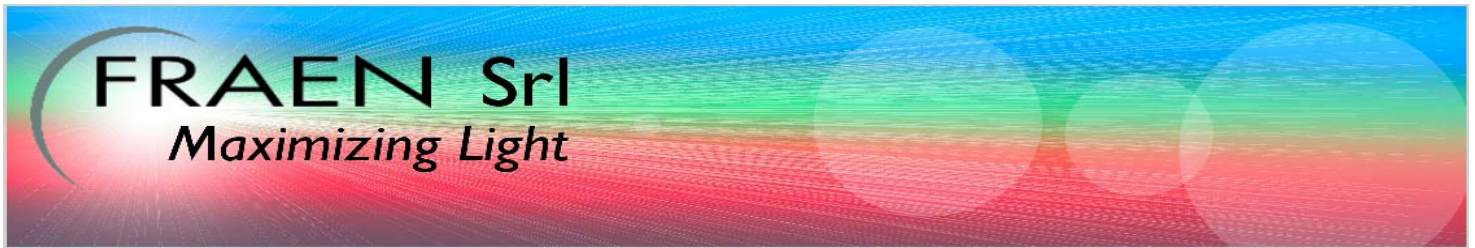

## Mechanical Characteristics

---

The Tri-lens modules, either Batwing and Lambertian, are only available with their holder because that holder:

- Keeps the 3 lenses together
- Sets the lenses at the right position on the LEDs to provide best efficiency.

*Please note that flow lines and weld lines on the external surfaces of the lenses are acceptable if the optical performance of the lens is within the specification described in the section "OPTICAL CHARACTERISTICS".*

## Mechanical Characteristics

### Lens + holder assembly view:

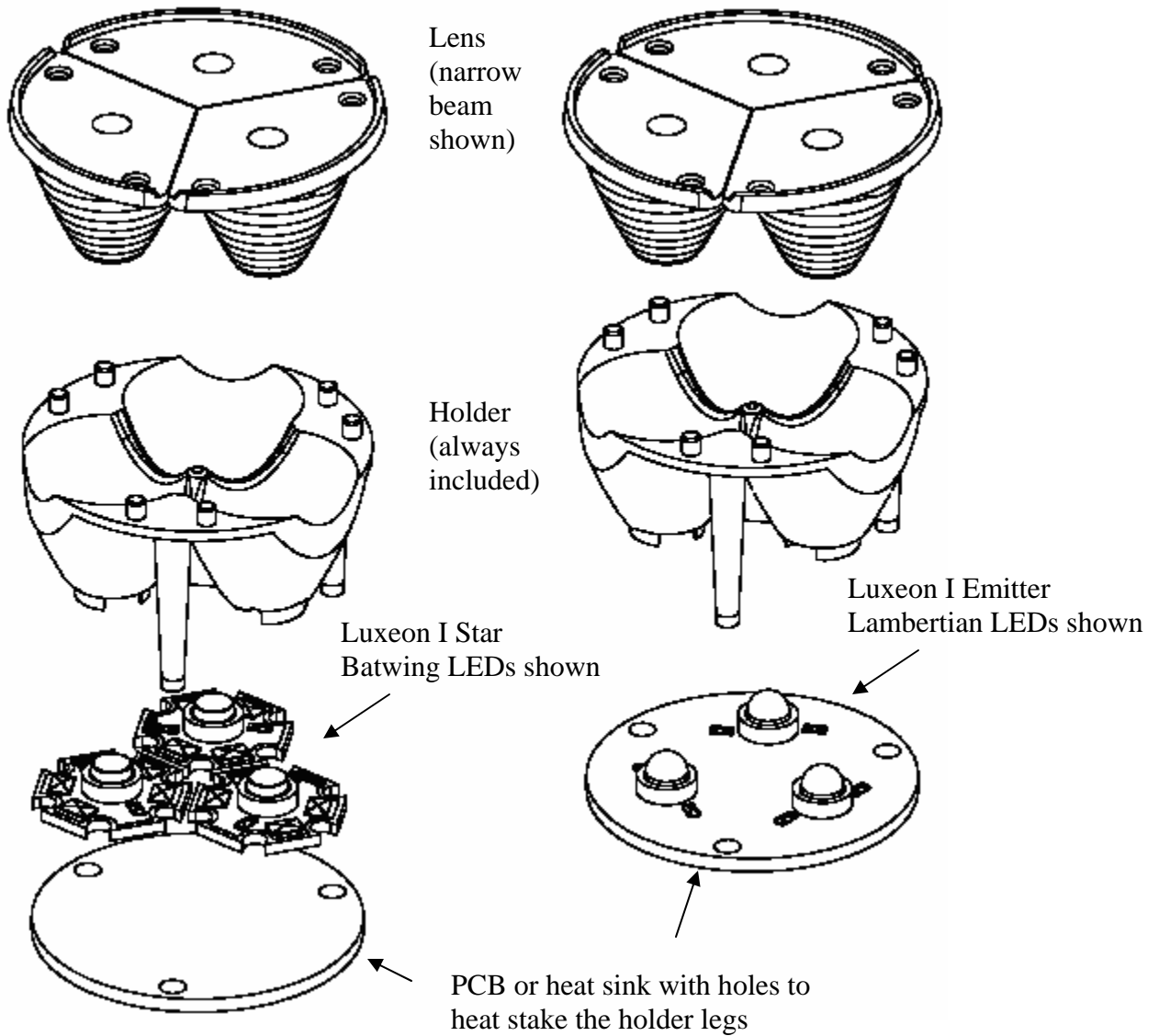

**Lens + holder assembly dimensions:**

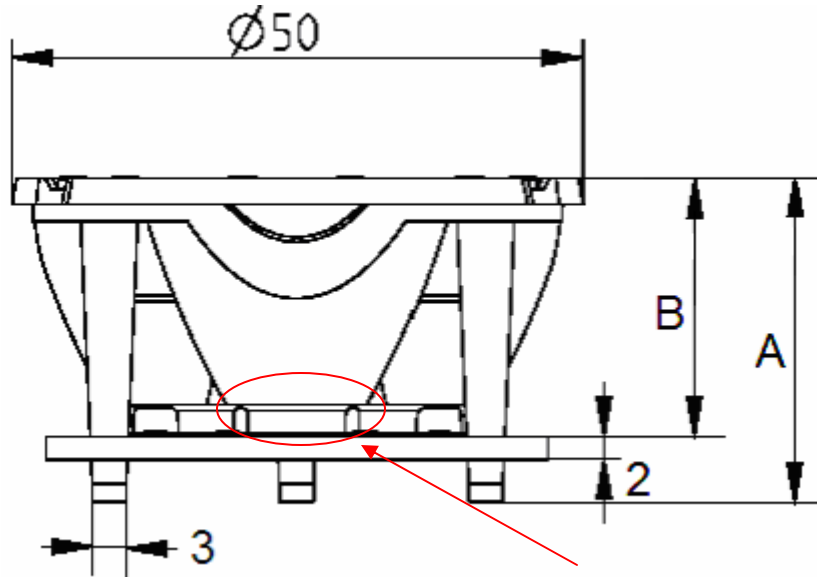

Shape of cutout in holder identifies the specific holder and application (Luxeon I Star, Luxeon III or V Star. or Emitter).

To assure the correct focal position of the lens and the Luxeon LED, specific holders have been designed. They can be identified by the shape of the cutout on the bottom of the holder:

Type of Luxeon LEDs used		Bottom of the holder	A	B
Batwing Luxeon LEDs	Star or Emitter		26.2mm	22,5mm
	Warm White Star		26.2mm	22mm
Lambertian Luxeon LEDs	Luxeon I Star Luxeon I, III or V Emitter		26.7mm	23.3mm
	Luxeon III or V Star		26.7mm	22.7mm

Dimensions tolerance is +/-0.2mm

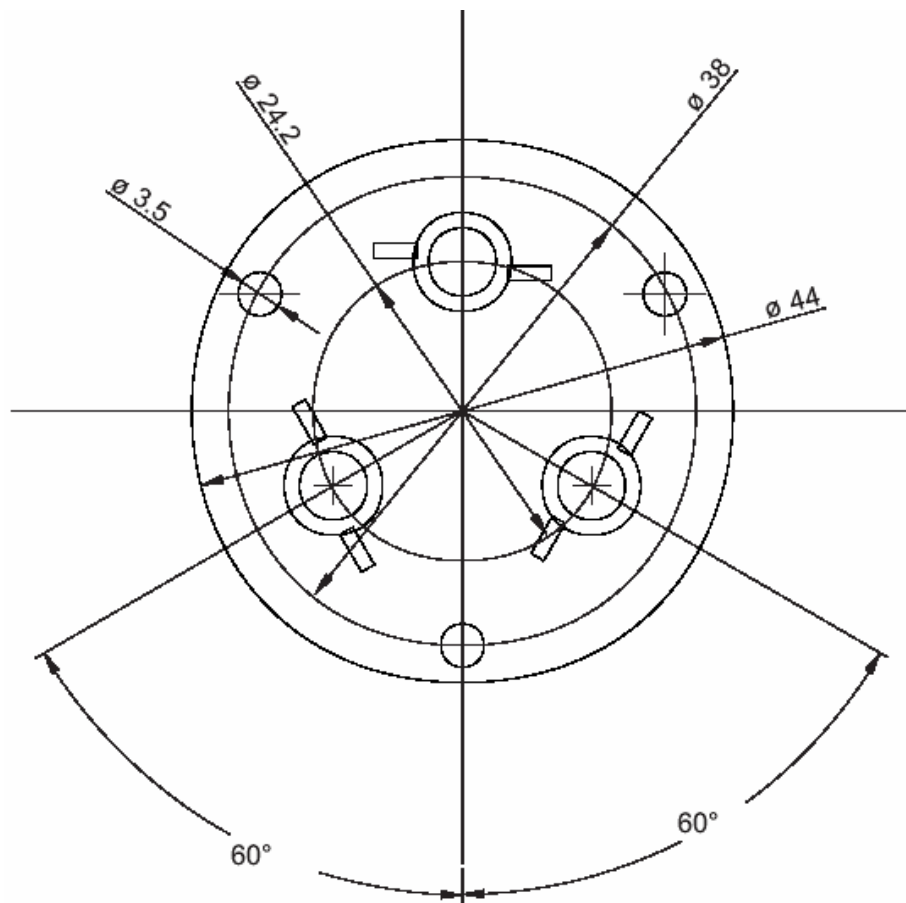

The outer geometry of all the Tri-lenses (Narrow, Medium and Wide beam) are the same for the different beams, except the top of the lens.  
 The lens can be identified by the top view:

**Top views (either Batwing or Lambertian):**

Narrow beam lens

Medium beam lens

Wide beam lens



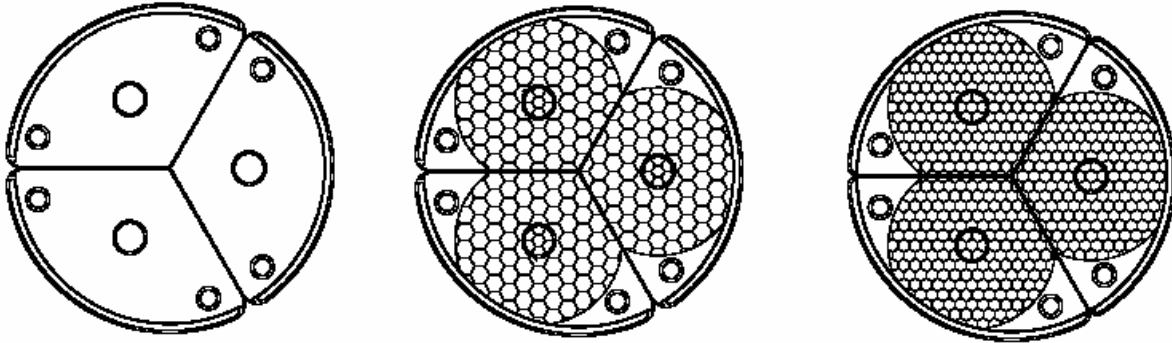

### Ordering part numbers

FT3-xxxx-yyyy-H

**LEDS TYPE:**

LB01: Luxeon I Batwing Star/Emitter  
LBSW: Luxeon I Batwing Star Warm White  
LL01: Luxeon I Lambertian Star/Emitter  
and Luxeon III/V Emitter  
LLS3: Luxeon III/V Lambertian Star

**LENS TYPE:**

HNB1: Narrow beam lens  
HMB1: Medium beam lens  
HWB1: Wide beam lens

Published by Fraen Corporation.

All technical data contained in this document are properties of Fraen Corporation and may change without notice.