

© COPYRIGHT 1998 BY SPC TECHNOLOGY. ALL RIGHTS RESERVED. NO PORTION OF THIS PUBLICATION, WHETHER IN WHOLE OR IN PART CAN BE REPRODUCED WITHOUT THE EXPRESS WRITTEN CONSENT OF SPC TECHNOLOGY.

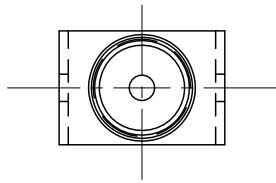

RoHS Compliant

| REVISIONS |     |             |       | DOC. NO. SPC-F005, Total Pages: 2                      |        |         |        |         |
|-----------|-----|-------------|-------|--|--------|---------|--------|---------|
|           |     |             |       | Effective: 7/15/97. DCP No: 229 Supersedes DCP No: 103 |        |         |        |         |
| DCP #     | REV | DESCRIPTION | DRAWN | DATE   | CHECKD | DATE    | APPRVD | DATE    |
| 1946      | A   | RELEASED    | SA    | 1/10/07  | JWM    | 3/19/07 | TL     | 3/19/07 |



**SPECIFICATIONS:**  
 SHELL AND TERMINAL: STEEL ELECTRO TIN PLATED OVER COPPER FLASH  
 SPRING: PHOS. BRONZE

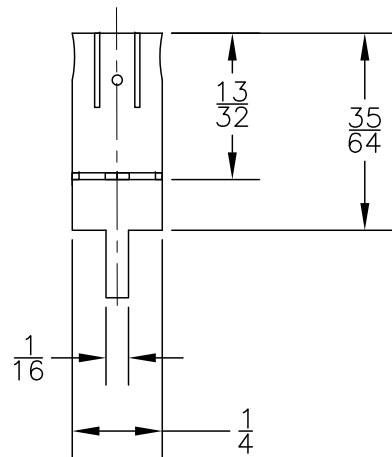
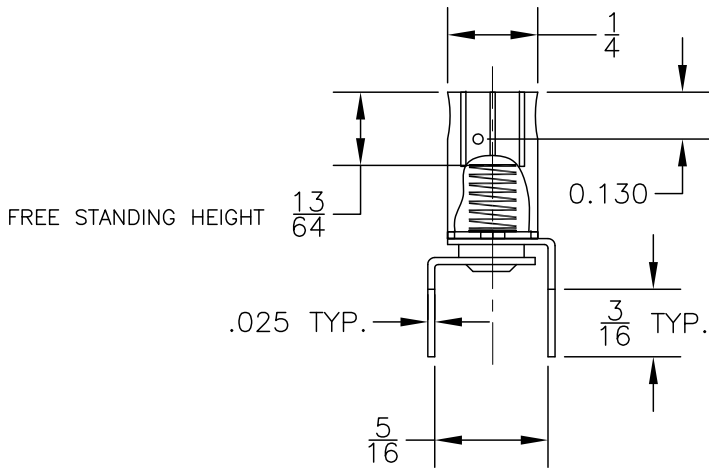

**DISCLAIMER:**  
 ALL STATEMENTS AND TECHNICAL INFORMATION CONTAINED HEREIN ARE BASED UPON INFORMATION AND/OR TESTS WE BELIEVE TO BE ACCURATE AND RELIABLE. SINCE CONDITIONS OF USE ARE BEYOND OUR CONTROL, THE USER SHALL DETERMINE THE SUITABILITY OF THE PRODUCT FOR THE INTENDED USE AND ASSUME ALL RISK AND LIABILITY WHATSOEVER IN CONNECTION THEREWITH.



**SPC TECHNOLOGY**

TOLERANCES UNLESS OTHERWISE SPECIFIED.

FRACTIONS: ±1/64

DECIMALS:  
 XX = ±.02  
 XXX = ±.005

|               |         |
|---------------|---------|
| DRAWN BY:     | DATE:   |
| SAMI ALNADI   | 1/10/07 |
| CHECKED BY:   | DATE:   |
| JEFF MCVICKER | 3/19/07 |
| APPROVED BY:  | DATE:   |
| THOMAS LEE    | 3/19/07 |

DRAWING TITLE:  
**MIDGET GROOVE BASE LAMPHOLDER, PC MOUNT**

|            |                |                 |     |
|------------|----------------|-----------------|-----|
| SIZE       | DWG. NO.       | ELECTRONIC FILE | REV |
| A          | SPC21774       | 16M1265.DWG     | A   |
| SCALE: NTS | U.O.M.: INCHES | SHEET: 1 OF 1   |     |

SPC-F005.DWG