

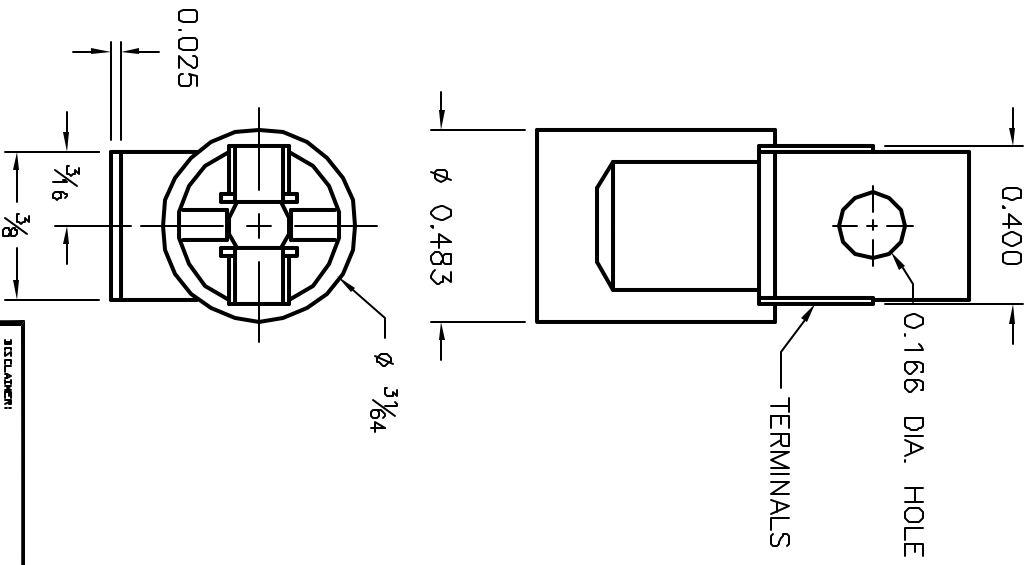

RoHS
Compliant



REVISONS		DOC. NO.	SPC-F005, Total Pages: 2	
DCP #	REV	DESCRIPTION	DATE	DATE
1948	A	RELEASED	1/10/07	3/19/07

- NOTES:**
1. SOLDER OR QUICK DISCONNECT TERMINALS WITH ELONGATED SLOTS, TAPERED TO ACCEPT AMP NO. 98 TAPER-TAB RECEPTACLES.
 2. TERMINAL MATERIAL: BRASS, ELECTRO - TIN PLATED OVER COPPER FLASH
 3. HOUSING: WEDGE BASE, NYLON INSULATED
 4. BRACKET MATERIAL: STEEL TO BE ZINC-PLATED AND CLEAR-PLATED.

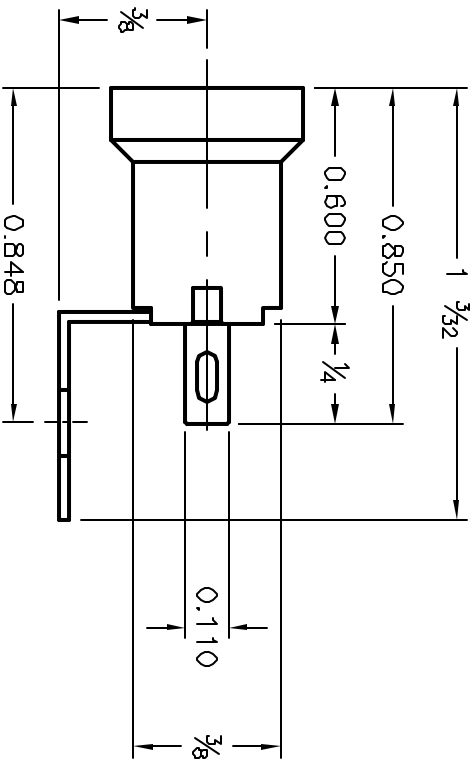

DISCLAIMER:
ALL STATEMENTS AND TECHNICAL INFORMATION CONTAINED HEREIN ARE BASED UPON INFORMATION AND/OR TESTS WE BELIEVE TO BE ACCURATE AND RELIABLE. SINCE CONDITIONS OF USE ARE BEYOND OUR CONTROL, THE USER SHALL DETERMINE THE SUITABILITY OF THE PRODUCT FOR THE INTENDED USE AND ASSUME ALL RISK AND LIABILITY WHATSOEVER IN CONNECTION THEREWITH.



SPC TECHNOLOGY

TOLERANCES UNLESS OTHERWISE SPECIFIED:
FRACTION: ±1/64
DECIMAL:
3 PLACES, ±.005

DRAWN BY:	DATE:
SAMI ALNADI	1/10/07
CHECKED BY:	DATE:
JEFF MCVICHER	3/19/07
APPROVED BY:	DATE:
THOMAS LEE	3/19/07

DRAWING TITLE:		SPC TECHNOLOGY	
Miniature Wedge Base Lampholder With 2 Terminals			
SIZE	DWG. NO.	ELECTRONIC FILE	REV
A	SPC21768	16M1259.DWG	A
SCALE:	NTS	U.O.M.: INCHES [mm]	SHEET: 1 OF 1