

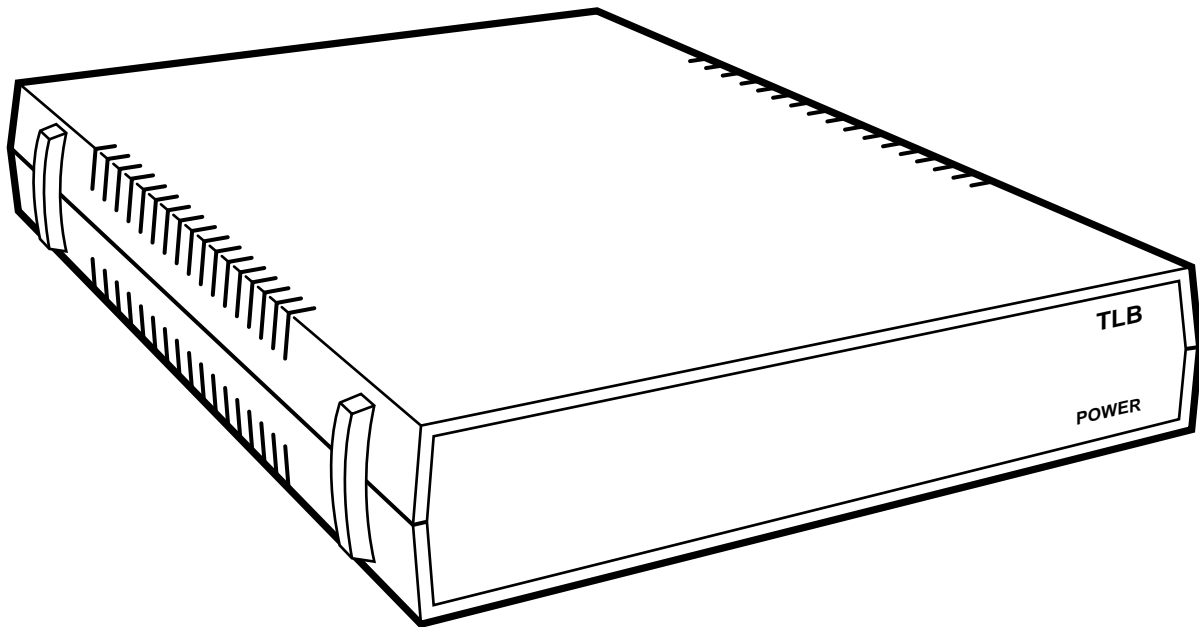

Telco Line Bridge (TLB)



**CUSTOMER
SUPPORT
INFORMATION**

Order **toll-free** in the U.S. 24 hours, 7 A.M. Monday to midnight Friday: **877-877-BBOX**
FREE technical support, 24 hours a day, 7 days a week: Call **724-746-5500** or fax **724-746-0746**
Mail order: **Black Box Corporation**, 1000 Park Drive, Lawrence, PA 15055-1018
Web site: www.blackbox.com • E-mail: info@blackbox.com

Telco Line Bridge (TLB) Installation and Operation Manual

1. Specifications

Power	Wallmount transformer, 115-VAC, 60 Hz <i>or</i> 230-VAC 50 Hz, at 5 Watts
Dimensions	Standalone: 2.5" H x 8.1" W x 11.9" D (6.4 x 20.6 x 30.2 cm) PC Card: 7.5" W x 10.5" D (19.1 x 26.7 cm) installs in rack (product code RM013)
Weight	Standalone: 3.0 lb. (1.4 kg)
Enclosure	High impact plastic
Operating Temperature	32° to 140°F (0 to 60°C)
Storage Temperature	4° to 158°F (-20 to 70°C)
Humidity	0—95% relative humidity, non-condensing
Connectors	(2) 10-screw terminal strips
Indicators	One LED for indicating power ON/OFF
Operating Mode	4-wire on Analog Leased Lines
Transmit Level With 0 dBm Input	Independently switch-selectable gain/attenuation of receive levels for each receive leg from -16 dB to +16 dB in 2 dB increments
Maximum Input for Undistorted	
Output (16 dB Loss Selected)	+10 dBm
Maximum Undistorted Output	+10 dBm
Minimum Channel Separation	30 dB typical
Frequency Response	300 Hz - 3 KHz, Gain variation less than +/- 0.75 dB typical
Absolute Accuracy of	
Gain/Loss Settings @ 1 KHz	+/- 0.75 dB typical
MTBF	Ground benign environment = 235,000 hrs Ground fixed environment = 157,000 hrs

2. Description

The Telco Line Bridge (TLB) is an active bridge for use on leased lines. The unit enables users to interface multiple analog telephone lines (four-wire type) to one modem. The TLB circuit is designed using operational amplifiers that are driven by 600 ohm transformers, thus maintaining proper line impedance. The output of the *op* amps is also matched to the analog line with 600 ohm transformers.

The unit has been designed to simultaneously broadcast any data received by the “master” input to each of four devices connected to the independently adjustable, transmit outputs. Any data received by the TLB on any one of its four independently adjustable receive inputs is transmitted out the “master” output. Normally, only one of these receive inputs is capable of receiving data at any one time. If data is received simultaneously by more than one receive input, the data transmitted out the “master” output may be unintelligible.

A typical application for the TLB is where a “master” modem is broadcasting data out to four “slave” modems and only one “slave” modem is allowed to send data back to the master modem at a time. In this application, each transmit and each receive leg to the slave modems can be independently set to compensate for varying line losses and receive requirements of the devices being used.

The TLB is available in both standalone and rack mounted versions. The Telco Line Bridge PC Card (TL205-C) is made to be inserted in the Telco Line Bridge Rack (RM013). This is a 19” rack capable of holding up to 12 printed circuit cards. The rack has its own power supply which is switch selectable for 115 VAC or 230 VAC operation.

PART NUMBER	DESCRIPTION
TL205A-R2	TELCO LINE BRIDGE STANDALONE UNIT (115 VAC)
TL205AE-R2.....	TELCO LINE BRIDGE STANDALONE UNIT (230 VAC)
TL205-C.....	TELCO LINE BRIDGE PRINTED CIRCUIT CARD
RM013	TELCO LINE BRIDGE RACK

3. Installation

1. Remove the cover from the TLB and connect the leased lines and the modem to terminal blocks TB1 and TB2 as shown in Figures 1 and 2. Cable ties have been included to provide strain relief for each cable.
2. Set the gain/attenuation for each transmit and each receive pair according to your system requirements. When you select a Gain for a particular leg, the gain/loss jumper for that circuit must be in the "gain" position. When you select a Loss for a particular leg, the gain/loss jumper must be in the "loss" position.

The gain/loss jumpers for the four transmit legs (T1, T2, T3, and T4) are W6, W7, W8, and W9. The gain/loss jumpers for the four receive legs (R1, R2, R3, and R4) are W2, W3, W4, and W5.
3. Once the gain/loss jumper is set, select the correct DIP switch settings on either S1, S2, S3, or S4 for the required gain of attenuation. Table 1 lists the DIP switch settings and jumper positions required for the available gain/attenuation settings.
4. Jumper position W1 is for tying frame ground to logic ground. The position is normally left open at the factory. If signal ground is to be connected to frame ground, it is recommended that a 100 ohm, half watt resistor be soldered in location W1. A wire jumper may also be used, but care must be taken to ensure that circulating ground currents are limited to acceptable levels.
5. Replace the cover and connect the power supply to the TLB. Then connect the power supply transformer to a wall receptacle of the proper voltage.

NOTE: Data received by the TLB on "RA" will be broadcast out all four transmit legs (T1 through T4) simultaneously. However, normally only one receive leg (R1 through R4) is capable of receiving data at any one time. If data is received on two or more receive legs simultaneously, the data output at "TA" may be unintelligible.

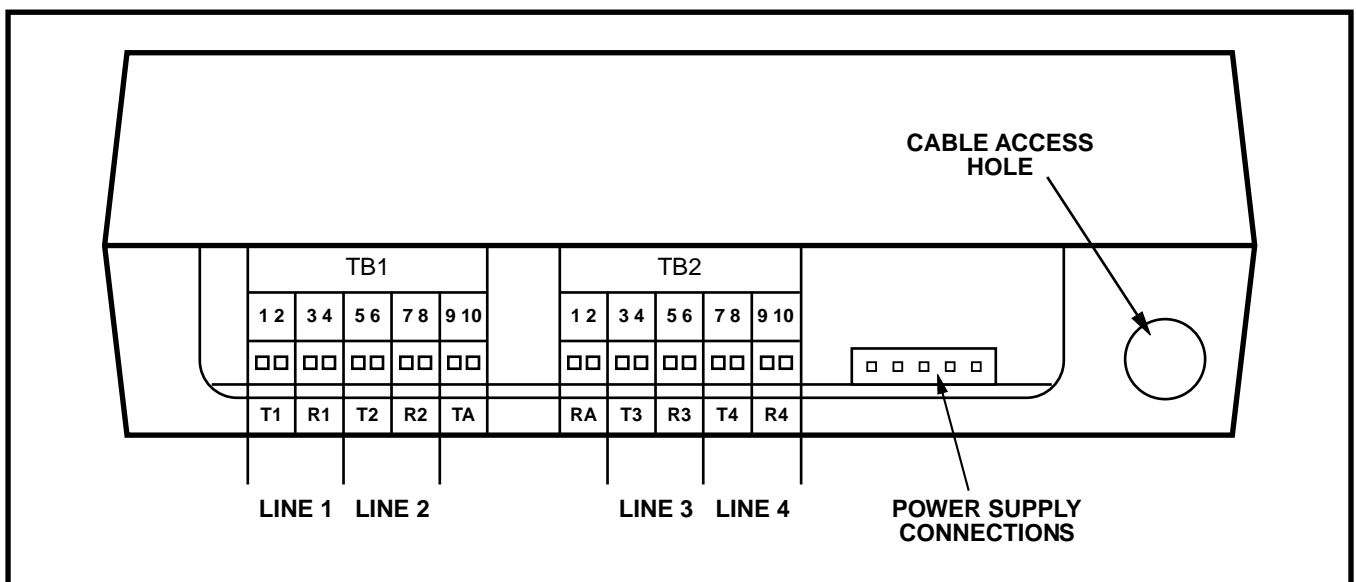

Figure 1. Rear View of the Telco Line Bridge

TELCO LINE BRIDGE (TLB)

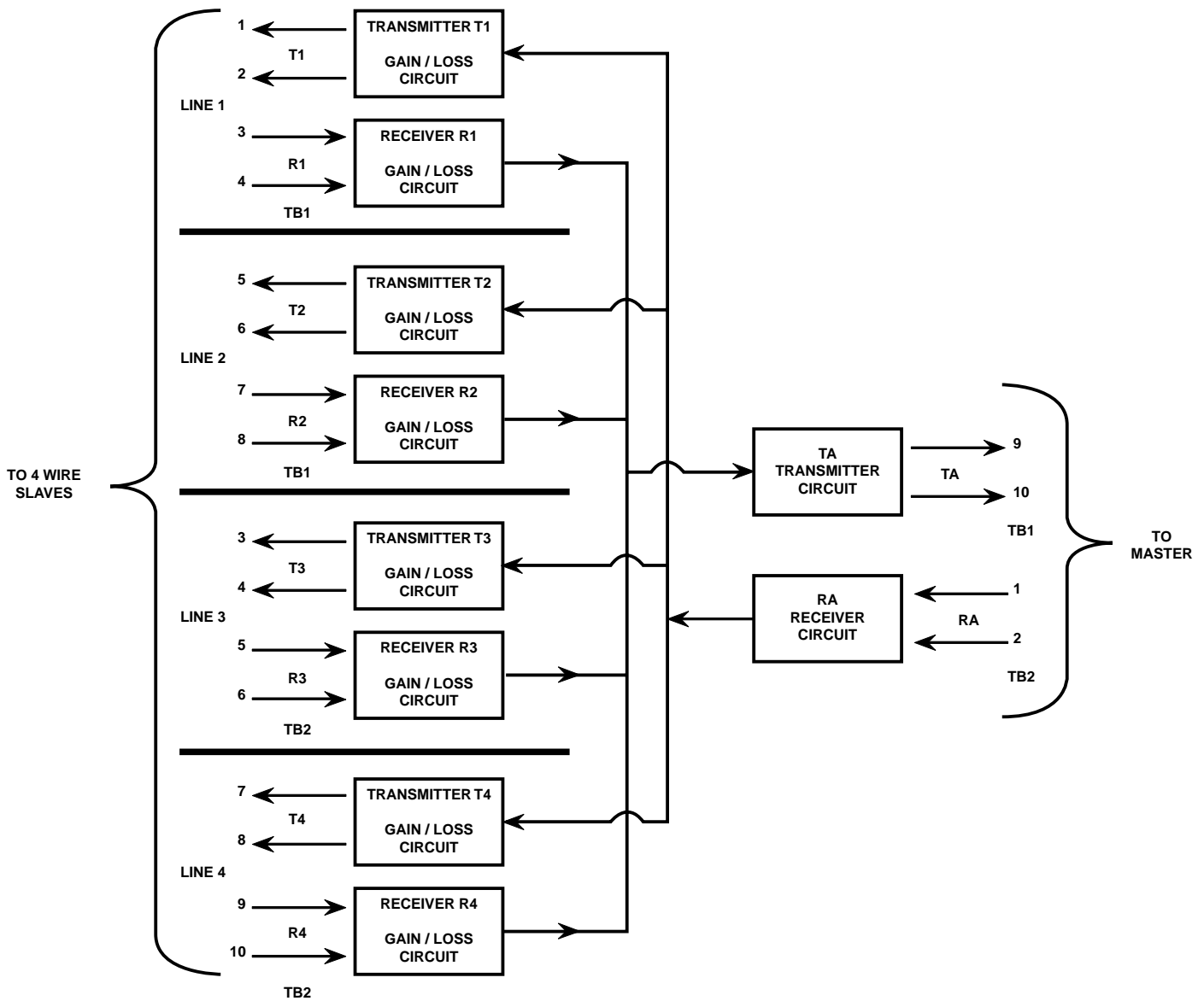

Figure 2. Functional Block Diagram and Connector Diagram

NOTE: The 20 terminals on the TLB connect only to the analog side of the modem and not to the RS-232 port.

Table 1. Gain/Attenuation Settings

Gain (In db) Position	Jumper Position	DIP Switch			
		A	B	C	D
-16	Loss	ON	ON	ON	ON
-14	Loss	OFF	ON	ON	ON
-12	Loss	ON	OFF	ON	ON
-10	Loss	OFF	OFF	ON	ON
-8	Loss	OFF	ON	OFF	ON
-6	Loss	OFF	OFF	OFF	ON
-4	Loss	ON	ON	ON	OFF
-2	Loss	OFF	OFF	ON	OFF
0*	Loss	OFF	OFF	OFF	OFF
0*	Gain	ON	ON	ON	ON
+2	Gain	OFF	ON	ON	ON
+4	Gain	ON	OFF	ON	ON
+6	Gain	OFF	OFF	ON	ON
+8	Gain	OFF	ON	OFF	ON
+10	Gain	OFF	OFF	OFF	ON
+12	Gain	ON	ON	ON	OFF
+14	Gain	OFF	OFF	ON	OFF
+16	Gain	OFF	OFF	OFF	OFF

* There are two possible positions for setting the 0 dB level. The setting with the jumper in the "gain" position and the four DIP switch positions all in the "ON" position will be slightly more accurate for most applications.

TELCO LINE BRIDGE (TLB)

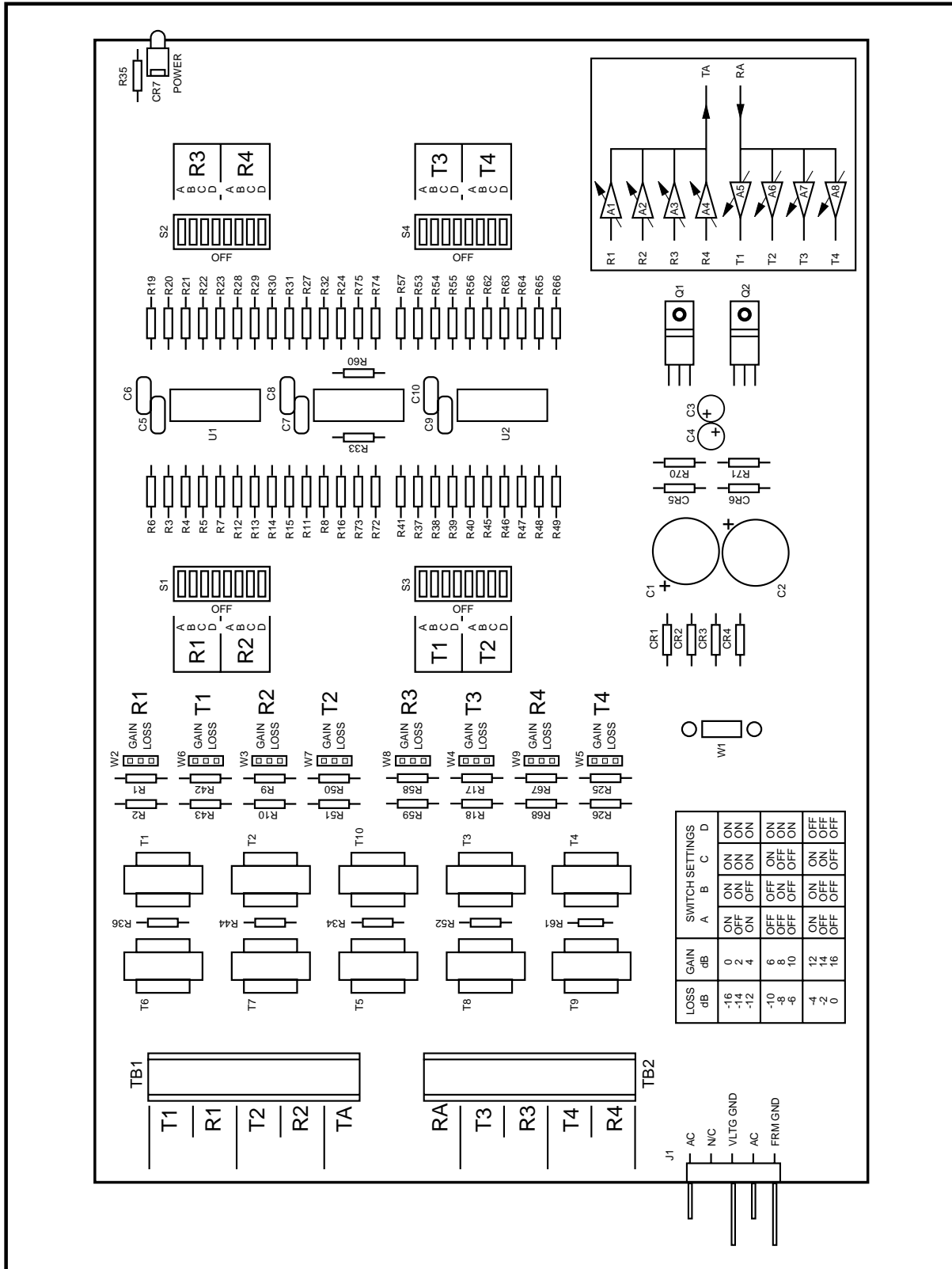

Figure 3. Telco Line Bridge Component Layout.

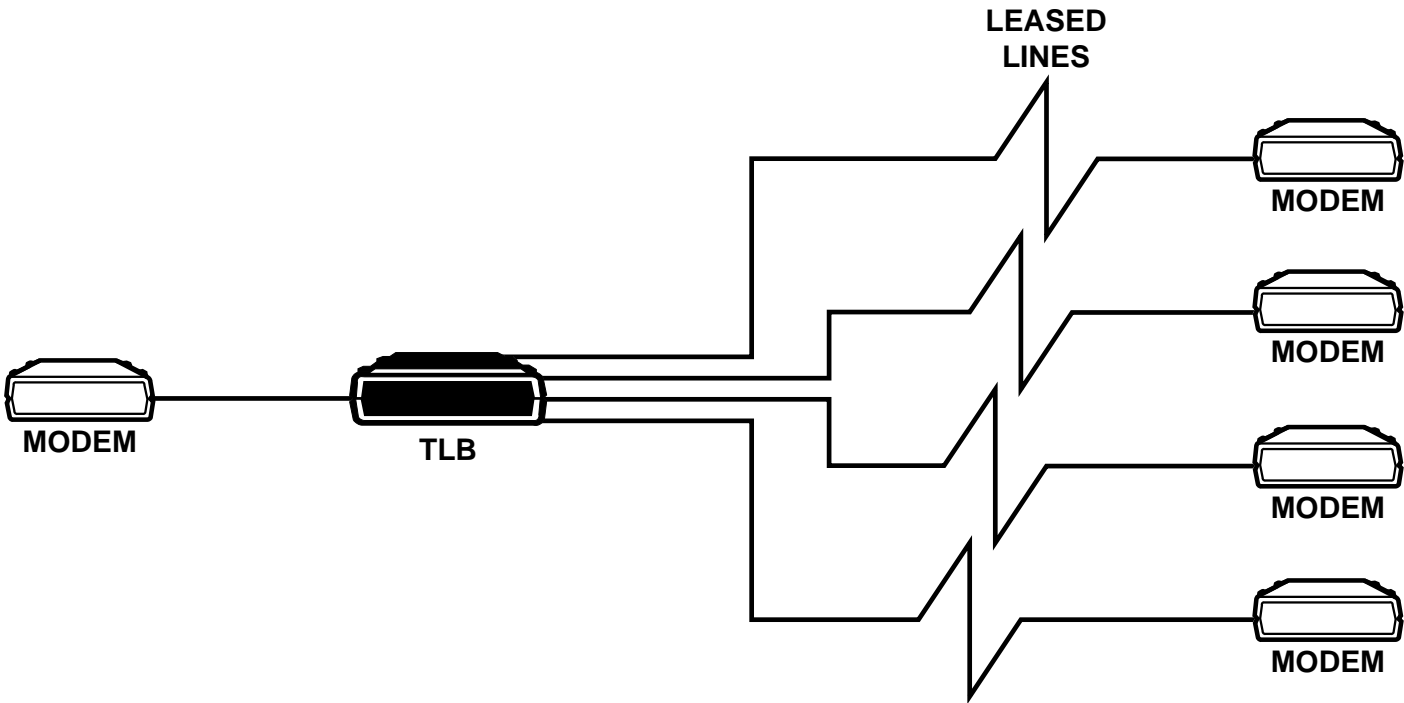
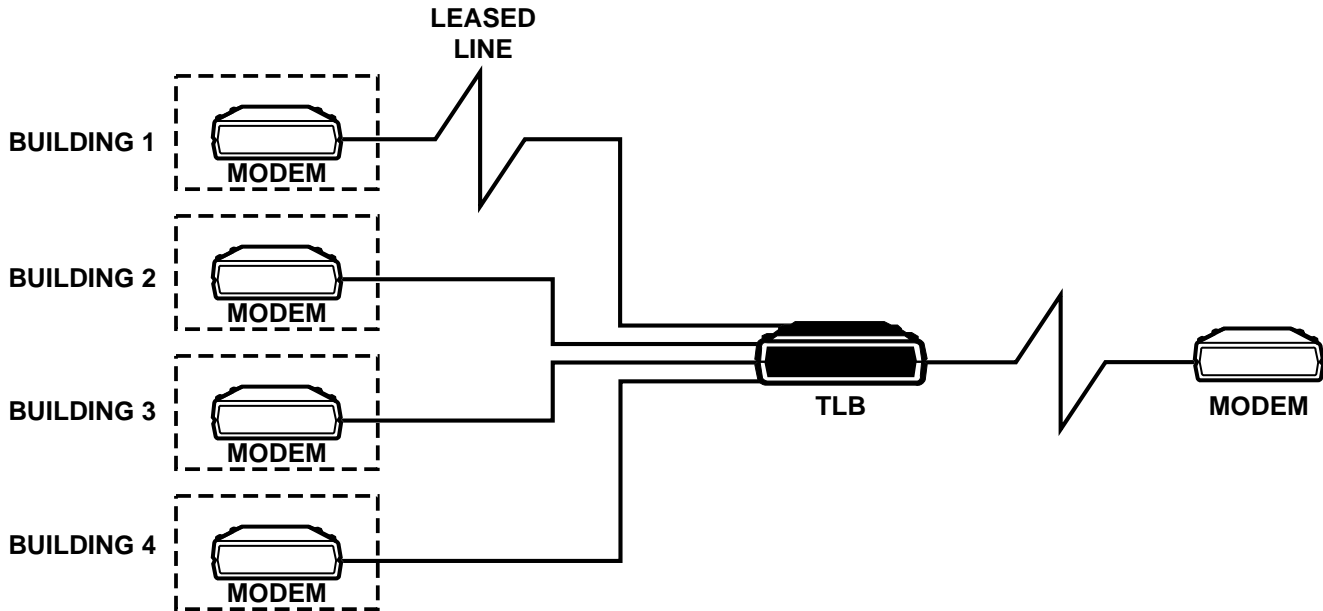

Figure 4. Two ways of using the Telco Line Bridge as a multidrop data broadcast.

TELCO LINE BRIDGE (TLB)

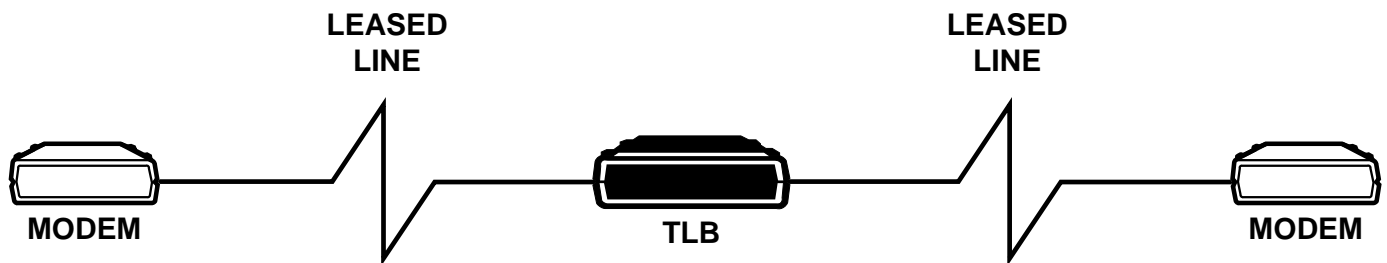

Figure 5. Using the Telco Line Bridge as a signal amplifier or attenuator.



© Copyright 1992. Black Box Corporation. All rights reserved.

1000 Park Drive • Lawrence, PA 15055-1018 • 724-746-5500 • Fax 724-746-0746