

AT-41586

Low Cost General Purpose Transistors



Data Sheet

Description

Avago's AT-41586 is a general purpose NPN bipolar transistor that offers excellent high frequency performance. The AT-41586 is housed in a low cost surface mount .085" diameter plastic package. The 4 micron emitter-to-emitter pitch enables this transistor to be used in many different functions. The 14 emitter finger interdigitated geometry yields an intermediate sized transistor with impedances that are easy to match for low noise and moderate power applications. Applications include use in wireless systems as an LNA, gain stage, buffer, oscillator, and mixer. An optimum noise match near 50Ω in the 1 to 2 GHz frequency range, makes this device easy to use as a low noise amplifier.

The AT-41586 bipolar transistor is fabricated using Avago's 10 GHz f_T Self-Aligned-Transistor (SAT) process. The die is nitride passivated for surface protection. Excellent device uniformity, performance and reliability are produced by the use of ion-implantation, self-alignment techniques, and gold metalization in the fabrication of this device.

86 Plastic Package

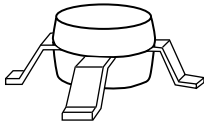

Pin Connections

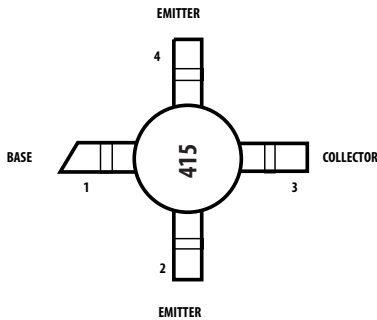

Features

- Low Noise Figure
1.4 dB Typical at 1 GHz
1.7 dB Typical at 2 GHz
- High Associated Gain
17.0 dB Typical at 1 GHz
12.5 dB Typical at 2 GHz
- Low Cost Surface Mount Package
- Tape and Reel Option Available
- Lead-free Option Available

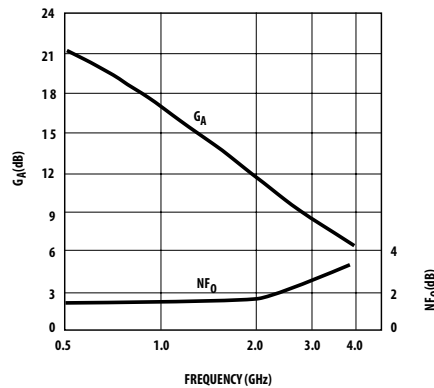

Figure 1. AT-41586 Noise Figure and Associated Gain vs. Frequency at $V_{CE} = 8 \text{ V}$, $I_C = 10 \text{ mA}$.

AT-41586 Absolute Maximum Ratings^[1]

Symbol	Parameter	Units	Absolute Maximum ^[1]
V_{EBO}	Emitter-Base Voltage	V	1.5
V_{CBO}	Collector-Base Voltage	V	20
V_{CEO}	Collector-Emitter Voltage	V	12
I_C	Collector Current	mA	60
P_T	Power Dissipation ^[2]	mW	500
T_j	Junction Temperature	°C	150
T_{STG}	Storage Temperature	°C	-65 to 150

Thermal Resistance:^[3]

$$\theta_{jc} = 165^\circ\text{C/W}$$

Notes:

1. Operation of this device above any one of these parameters may cause permanent damage.
2. $T_{CASE} = 25^\circ\text{C}$.
3. See MEASUREMENTS section, "Thermal Resistance," for more information.

Electrical Specifications, $T_A = 25^\circ\text{C}$, $V_{CE} = 8\text{ V}$

Symbol	Parameters and Test Conditions	Unit	Min.	Typ.	Max.	
NF_0	Optimum Noise Figure: $I_C = 10\text{ mA}$	f = 1.0 GHz f = 2.0 GHz f = 4.0 GHz	dB	1.4 1.7 3.0		
G_A	Gain @ NF_0 : $I_C = 10\text{ mA}$	f = 1.0 GHz f = 2.0 GHz f = 4.0 GHz	dB	17.0 12.5 8.0		
$ S_{21E} ^2$	Insertion Power Gain: $I_C = 25\text{ mA}$	f = 1.0 GHz f = 2.0 GHz	dB	17.0 11.0		
P_{1dB}	Power Output @ 1 dB Gain Compression: $I_C = 25\text{ mA}$	f = 2.0 GHz	dBm	18.0		
G_{1dB}	1 dB Compressed Gain: $I_C = 25\text{ mA}$	f = 2.0 GHz	dB	13.0		
f_T	Gain Bandwidth Product: $I_C = 25\text{ mA}$		GHz	8.0		
h_{FE}	Forward Current Transfer Ratio: $I_C = 10\text{ mA}$			30	150	270
I_{CBO}	Collector Cutoff Current: $V_{CB} = 8\text{ V}$		μA		0.2	
I_{EBO}	Emitter Cutoff Current: $V_{EB} = 1\text{ V}$		μA		1.0	

Note:

1. For more information on outlines 86, refer to "Tape and Reel Packaging for Surface Mount Devices."

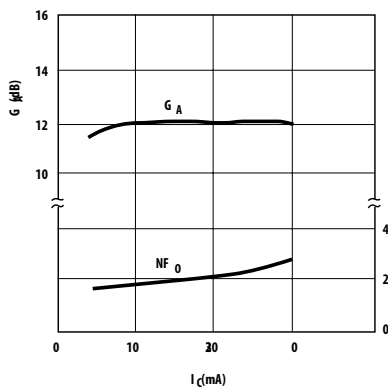

Figure 2. AT-41586 Optimum Noise Figure and Associated Gain vs. Collector Current at $V_{CE} = 8\text{ V}$, $f = 2.0\text{ GHz}$.

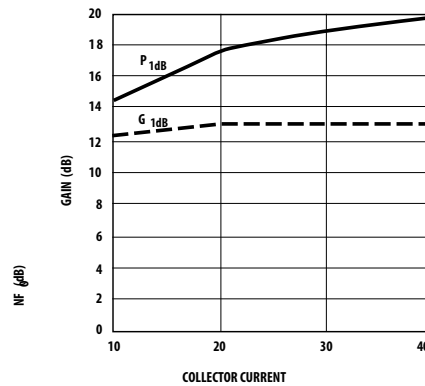

Figure 3. AT-41586 P_{1dB} and G_{1dB} vs. Collector Current at $V_{CE} = 8\text{ V}$, $f = 2.0\text{ GHz}$.

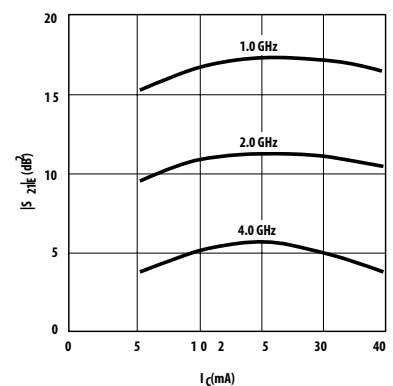

Figure 4. AT-41586 Insertion Power Gain vs. Collector Current and Frequency at 25°C , $V_{CE} = 8\text{ V}$.

AT-41586 Typical Scattering Parameters at $T_A = 25^\circ\text{C}$

$V_{CE} = 8\text{ V}$, $I_C = 10\text{ mA}$, $Z_o = 50\ \Omega$

Frequency (GHz)	S_{11}			S_{21}			S_{12}		S_{22}	
	Mag.	Ang.	(dB)	Mag.	Ang.	(dB)	Mag.	Ang.	Mag.	Ang.
0.100	0.78	-39	28.4	26.3	154	-36.4	0.015	71	0.91	-16
0.200	0.71	-71	26.9	22.1	134	-31.7	0.026	59	0.79	-27
0.300	0.65	-95	25.2	18.1	122	-29.8	0.032	50	0.67	-34
0.400	0.61	-113	23.5	15.0	119	-28.8	0.036	44	0.58	-38
0.500	0.59	-127	22.0	12.6	114	-28.1	0.039	43	0.52	-40
0.600	0.57	-137	20.7	10.8	100	-27.5	0.042	43	0.47	-40
0.700	0.56	-146	19.6	9.5	95	-27.1	0.044	43	0.44	-41
0.800	0.56	-154	18.5	8.4	91	-26.5	0.047	43	0.42	-41
0.900	0.55	-160	17.6	7.6	86	-26.1	0.049	44	0.40	-42
1.000	0.55	-166	16.8	6.9	83	-25.8	0.051	47	0.38	-42
1.500	0.55	173	13.4	4.7	70	-23.8	0.064	49	0.34	-45
2.000	0.57	157	10.9	3.5	57	-22.0	0.079	49	0.32	-52
2.500	0.59	144	9.2	2.9	44	-20.6	0.093	48	0.31	-61
3.000	0.62	133	7.6	2.4	34	-19.3	0.108	47	0.30	-71
3.500	0.64	123	6.0	2.0	25	-18.1	0.124	45	0.30	-83
4.000	0.67	114	5.1	1.8	16	-17.0	0.141	42	0.31	-95
4.500	0.70	106	4.1	1.6	5	-15.9	0.159	39	0.32	-108
5.000	0.73	99	2.9	1.4	-3	-15.0	0.176	35	0.32	-121
5.500	0.76	93	1.6	1.2	-8	-14.2	0.193	31	0.34	-135
6.000	0.78	88	0.8	1.1	-18	-13.5	0.209	31	0.36	-150

AT-41586 Typical Noise Parameters at $T_c = 25^\circ\text{C}$,

$Z_o = 50\ \Omega$, $I_C = 10\text{ mA}$, $V_{CE} = 8\text{ V}$

Frequency (GHz)	NF_0 (dB)	Γ_{opt} Mag.	Ang.	$R_N/50\ \Omega$
0.1	1.3	0.12	3	0.17
0.5	1.3	0.10	16	0.17
1.0	1.4	0.04	43	0.16
2.0	1.7	0.12	-145	0.16

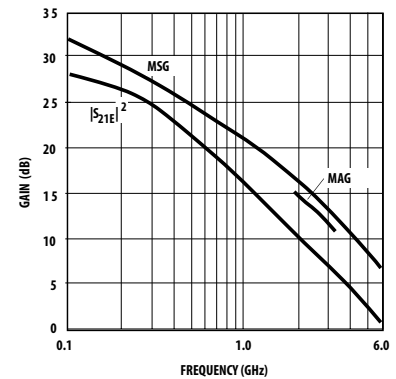

Figure 5. AT-41586 Insertion Power Gain, Maximum Available Gain and Maximum Stable Gain vs. Frequency at $V_{CE} = 8\text{ V}$, $I_C = 10\text{ mA}$.

AT-41586 Typical Scattering Parameters at $T_A = 25^\circ\text{C}$

$V_{CE} = 8\text{ V}$, $I_C = 25\text{ mA}$, $Z_o = 50\ \Omega$

Frequency (GHz)	S_{11}			S_{21}			S_{12}		S_{22}	
	Mag.	Ang.	(dB)	Mag.	Ang.	(dB)	Mag.	Ang.	Mag.	Ang.
0.100	0.64	-61	31.9	39.4	154	-37.0	0.014	64	0.82	-24
0.200	0.59	-101	29.2	28.7	169	-33.1	0.022	53	0.64	-35
0.300	0.56	-125	26.6	21.4	124	-31.7	0.026	49	0.53	-38
0.400	0.55	-140	24.6	17.0	111	-30.4	0.030	49	0.47	-39
0.500	0.54	-151	22.9	14.0	104	-29.6	0.033	50	0.43	-38
0.600	0.54	-159	21.4	11.7	97	-28.8	0.036	52	0.40	-38
0.700	0.54	-166	20.1	10.1	91	-28.1	0.039	53	0.40	-37
0.800	0.54	-171	19.0	8.9	86	-27.5	0.042	55	0.38	-37
0.900	0.54	-176	18.0	7.9	81	-26.9	0.045	56	0.37	-37
1.000	0.55	177	17.1	7.2	77	-26.3	0.048	57	0.36	-37
1.500	0.57	164	13.6	4.8	64	-23.8	0.064	59	0.34	-42
2.000	0.57	152	11.1	3.6	55	-21.9	0.080	57	0.32	-49
2.500	0.60	141	9.2	2.9	44	-20.0	0.100	55	0.31	-58
3.000	0.62	132	7.6	2.4	34	-18.4	0.120	52	0.31	-68
3.500	0.64	124	6.4	2.1	24	-17.0	0.140	49	0.31	-80
4.000	0.67	116	5.6	1.9	18	-14.8	0.180	45	0.32	-94
4.500	0.70	109	4.1	1.6	9	-15.9	0.160	45	0.30	-109
5.000	0.73	102	3.5	1.5	1	-15.3	0.170	42	0.30	-123
5.500	0.77	96	2.3	1.3	-7	-14.4	0.190	38	0.32	-138
6.000	0.76	90	1.6	1.2	-14	-13.9	0.200	33	0.35	-152

Outline 86 Dimensions

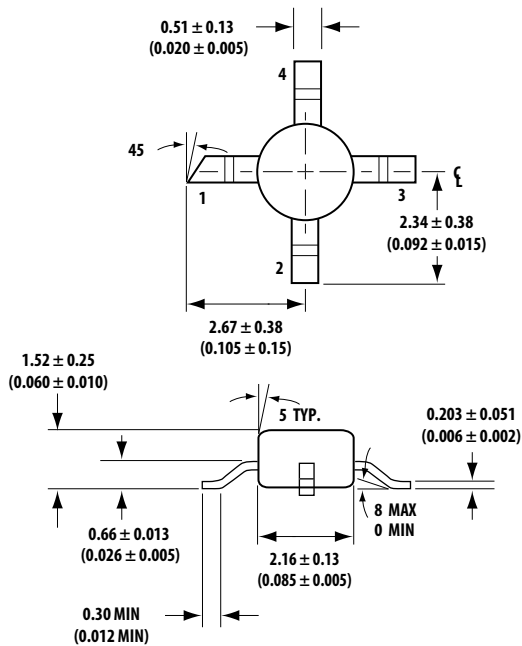

DIMENSIONS ARE IN MILLIMETERS (INCHES)

Ordering Information

Part Numbers	No. of Devices	Comments
AT-41586-BLKG	100	Bulk
AT-41586-TR1G	1000	7" Reel
AT-41586-TR2G	4000	13" Reel

Device Orientation

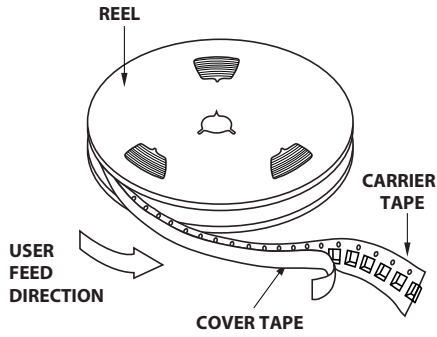

Tape Dimensions and Product Orientation

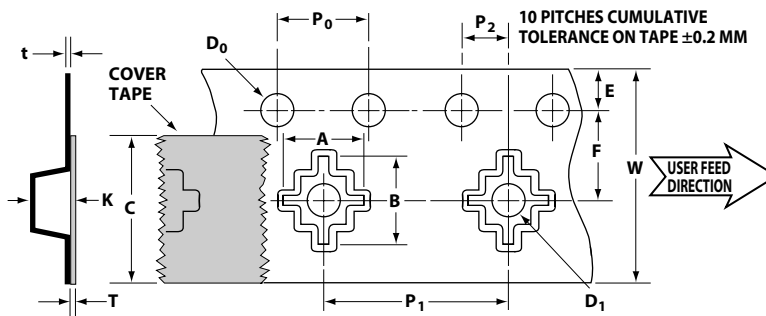

DESCRIPTION		SYMBOL	SIZE (mm)	SIZE (INCHES)
CAVITY	LENGTH	A_0	6.45 ± 0.10	0.254 ± 0.004
	WIDTH	B_0	5.13 ± 0.10	0.202 ± 0.004
	DEPTH	K_0	2.11 ± 0.10	0.083 ± 0.004
	PITCH	P_1	8.00 ± 0.10	0.315 ± 0.004
	BOTTOM HOLE DIAMETER	D_1	1.50 min.	0.059 min.
PERFORATION	DIAMETER	D_0	$1.50 + 0.10/-0$	$0.059 + 0.004/-0$
	PITCH	P_0	4.00 ± 0.10	0.157 ± 0.004
	POSITION	E	1.75 ± 0.10	0.069 ± 0.004
CARRIER TAPE	WIDTH	W	8.00 ± 0.30	0.315 ± 0.012
	THICKNESS	t	0.255 ± 0.013	0.0100 ± 0.0005
COVER TAPE	WIDTH	C	9.19 ± 0.10	0.362 ± 0.004
	TAPE THICKNESS	T_t	0.051 ± 0.010	0.0020 ± 0.0004
DISTANCE BETWEEN CENTERLINE	CAVITY TO PERFORATION (WIDTH DIRECTION)	F	5.51 ± 0.05	0.217 ± 0.002
	CAVITY TO PERFORATION (LENGTH DIRECTION)	P_2	2.00 ± 0.05	0.079 ± 0.002

For product information and a complete list of distributors, please go to our web site: www.avagotech.com

Avago, Avago Technologies, and the A logo are trademarks of Avago Technologies in the United States and other countries. Data subject to change. Copyright © 2005-2008 Avago Technologies. All rights reserved. Obsoletes 5989-2651EN AV02-1459EN - August 8, 2008

AVAGO
TECHNOLOGIES