

### Features:

- \* Universal AC Input 90—264Vac
- \* Low ripple & noise
- \* No minimum load requirement
- \* 100% burn in test
- \* 1 year warranty
- \* Safety: UL, CUL, GS, CB, CE, FCC



### SPECIFICATION:

MODEL NO.	DSA-60W-12-1	DSA-60W-12-2	DSA-60W-20-1				
PART NO.	T3637ST	T3636ST	T3834ST				
OUTPUT:							
Voltage	12VDC	12VDC	24VDC				
Current (Max)	5A	5A	2.5A				
Current (Min)	0A						
Line Regulation	+/-2%						
Output Regulation	+/-5%						
Over Voltage Protection	15.6VDC Max Zener Clamped	15.6VDC Max Zener Clamped	31VDC Max Zener Clamped				
Over Current Protection	10A Max With Auto Recovery	10A Max With Auto Recovery	5A Max With Auto Recovery				
Ripple Voltage (L.F)	120mV P-P	120mV P-P	240mV P-P				
O/P Connector ( 1.8M Jack Lead )	2.1x5.5x12mm Centre +VE R/A						
SAFETY:							
Hi Pot Test I/P-O/P	1.5KVAC or 2121VDC	3KVAC or 4242VDC	1.5KVAC or 2121VDC				
Insulation I/P-O/P	50Mohms						
Earth Continuity	<100mOhms	N/A	<100mOhms				
TEMPERATURE:							
Operating	0 to 40°C						
Storage	-20 to 60°C						
HUMIDITY:							
Operating	20 to 85%		Non Condensing				
Storage	5 to 95%		Non Condensing				
INPUT:							
Voltage	90 to 264VAC						
Frequency	47 to 63Hz						
Current RMS (Max)	1.5A						
Input Plug Type	IEC320 C14	IEC320 C8	IEC320 C14				
Leakage Current	3.5mA	0.25mA	3.5mA				
Efficiency (Min)	80%						
MTBF	50K Hours						
Safety	EN 60950-1,	UL 60950-1					
Additional Safety							
EMI	EN 55022,	EN 61000-3-2,	EN 61000-3-3				
EMC	EN 55024						

1 ARKWRIGHT ROAD, READING, BERKS. RG2 0LU  
 TEL: 0118 9311199 FAX: 0118 9311145  
 E-Mail: [info@stontronics.co.uk](mailto:info@stontronics.co.uk) [www.stontronics.co.uk](http://www.stontronics.co.uk)

**Dimensions:**

**Weight: 310g Approx.**

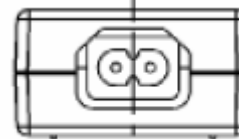
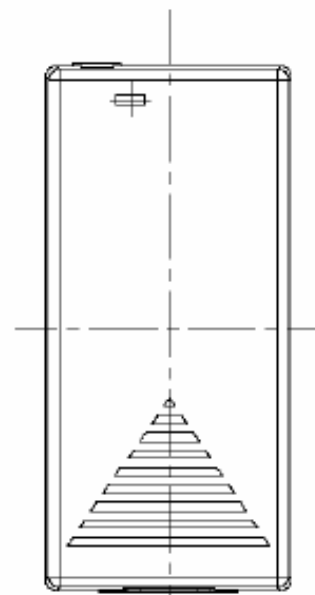
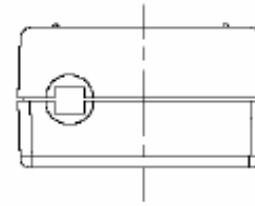
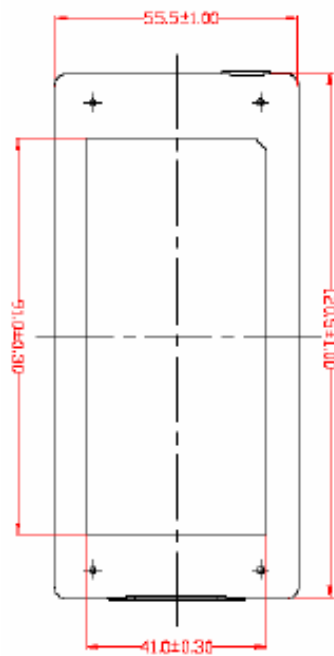

**C8 Mains Input**

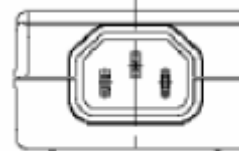

**C14 Mains Input**

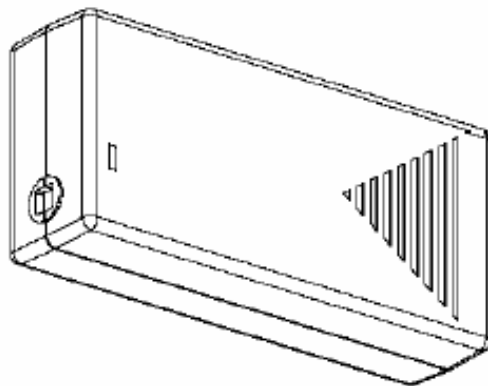

**1 ARKWRIGHT ROAD, READING, BERKS. RG2 0LU**

**TEL: 0118 9311199**

**FAX: 0118 9311145**

**E-Mail: [info@stontronics.co.uk](mailto:info@stontronics.co.uk) [www.stontronics.co.uk](http://www.stontronics.co.uk)**