

# Approval Sheet

FOR Nordic/

PART NO.: SAL115A-1510U-6

DESIGNED NO.: A6030152-2(SMP3080063)

TYPE:

DATE: August 20, 2003

APPROVED BY (PLEASE SIGN)

25/11-03 <i>[Signature]</i>	25/11-03 WORK POWER <i>[Signature]</i>		
--------------------------------	--	--	--

H. Backmark

思 慈 有 限 公 司



ONTOP CO., LTD.

-DIV. OF SAC GROUP-

台北市中山北路六段一六一號二樓之二

2F-2, 161, CHUNG SHANG N. RD. SEC. 6, TAIPEI, TAIWAN

TEL:++886-2-2838 2606

FAX:++886-2-2838 2604



## 15W AC to DC Switching Power Adapter Specification

Model Name : SAL115A-1510U-6

### INDEX

1.) Electrical Specification

2.) Mechanical Drawing

3.) Temperature Test

CUSTOMER :

DATE : 8/20/92

MODEL NO. : SAL115A-1510U-6

PART NO. :

CHANGE NOTICE

ORIGINAL DESIGN NO. : A6030152-1	REVISED DESIGN No. : A6030152-2
----------------------------------	---------------------------------

1.Pluge :2.1\*5.5\*11 S

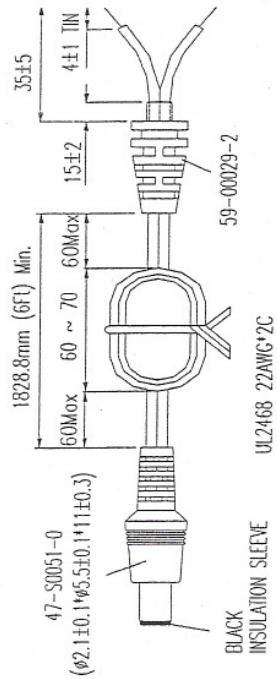

1. Pluge: (RJ11 Phone Jack)如下圖

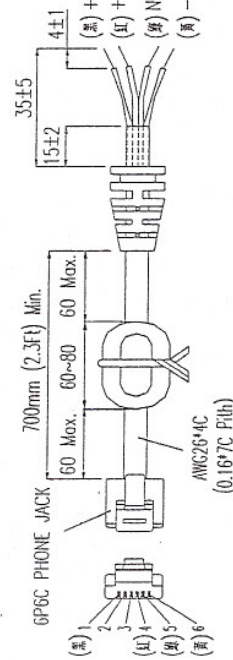

Customer Approved by :

PRODUCTION REVISION HISTORY :

REV.	DATE	BY:	DESCRIPTION OF CHANGE
-2	8/20/92		1.依客戶要求變更Pluge

Designed by : Peter Wang

Checked by :



Approved by :



SAC AC to DC SWITCHING ADAPTER SPECIFICATION	MODEL:	SAL115A-1510U-6	Design NO:	A6030152-2
---	--------	-----------------	------------	------------

## 1. DESCRIPTION.

- 1.1 This specification is suitable for :
- 1.2 This adapter is used for : B002 無線電話
- 1.3 This product is AC to DC switching power transfer device, it can provide for a 8.16W dc output with constant voltage source.

## 2. SURFACE , STRUCTURE.

- 2-1 Surface damage , rusting etc. is not permitted.
- 2-2 Appearance , dimension and description : As drawing.

## 3. ELECTRICAL CHARACTERISTICS.

- 3-1 Input Voltage :
  - a. Rated Voltage, 100~240 Vac
  - b. Max. Voltage, 90~264 Vac
- 3-2 Input Frequency :
 

47~63Hz
- 3-3 Input Current :
 

400 mA (Max.) @ 100Vac/50Hz with full load
- 3-4 Output Voltage and Current(dc) :

	Voltage (Vdc)	Current (mA)	Voltage (Vdc)	Current (mA)
O/P	13.6±5%	0	13.6±5%	600

### 3-4-1 Line Regulation :

The line regulation is less than ±2%, @ full load and ±10% input voltage.

3-4-2 Load Regulation :

The load regulation is less than  $\pm 5\%$ .

3-5 Efficiency :

80% (Min.) , @ AC Input 100Vac/50 Hz with full load.

75% (Min.) , @ AC Input 240Vac/50 Hz with full load.

3-6 Ripple and Noise Voltage : (At full load)

At O/P=13.6Vdc  $\leq 150$  mVp-p

The measuring terminated with a 10uF EC-Capacitor and 0.1uF CC-Capacitor , and measurement is done by 20MHz band-width.

3-7 Safety Test :

3-7-1 Hi -Pot Test :

3000 Vac, 5mA, 1 Sec. between Primary and Secondary circuit and chassis.

3-7-2 Insulation Test :

500Vdc, 1 minute between Primary and Secondary circuit and chassis,  
IR should  $\geq 100M\Omega$ .

3-7-3 Leakage Current :  $\leq 0.25mA$  , at 240Vac / 50Hz

3-8 Temperature Rise : (Use thermometer).

AC input 100 V / 50 Hz with full load, shall not exceed 45K on case surface  
@ ambient 25°C.

3-9 Transient Response : < 10%, @ output change between 50% and 100% of full load,  
slew rate is 0.5A/us, frequency is 100Hz and 10KHz.

3-10 Hold Up Time :  $\geq 8$  mSec., @ 100Vac/50Hz, ambient 25°C with full load.

3-11 Rise Time :  $\leq 20$  mSec., @ 100Vac/50Hz, ambient 25°C with full load from 5% to 95% of Vo.

3-12 Inrush Current :  $\leq 70A$  at 100 ~ 240Vac.  
At cold start, Maximum Load, ambient 25°C :

3-13 No load Power Consumption (Off Mode) :  $\leq 1$  Watts,  
At 240Vac/50Hz, ambient 25°C

#### 3-14 PROTECTION CHARACTERISTICS :

3-14-1 Over Voltage Protection Clamping on 120%~160% Vo

3-14-2 Over Load Protection Current : 1.5 ~ 3.5 A @ 100~240Vac, ambient 25°C.

3-14-3 Short Protection :

The adapter can withstand continuous short at DC output and no damage. It will enter into normal condition if the fault condition is removed.

#### 4. ENVIRONMENT.

4-1 Operating Temperature : 0°C ~ + 40°C

4-2 Operating Humidity : 20% to 80 %R.H.

4-3 Storage Temperature : -20°C ~ + 80°C

4-4 Storage Humidity : 10% to 95 %R.H.

#### 5. RELIABILITY.

5-1 MTBF : (When calculated using MIL-HDBK-217F)  
100,000 hours at 25°C

## 6. SAFETY.

Safety Status :  V  Applicable   Not applicable

Agency	Standards	Note
CUS	UL60950	
CSA	C22.2 No.60950	
TUV/GS	EN60950	
PSE		
CB	IEC60950	
CE	EN55022 / EN55024	

## 7. EMS & EMI.

### 7-1 EMS :

Items	Specification	Reference
ESD	Contact : $\geq 4KV$	IEC61000-4-2
	Non-Contact : $\geq 8KV$	
RS	Frequency : 80MHz~1.0GHz, Field Strength : 3V/M	IEC61000-4-3
EFT	1.0KV on input ac power ports.	IEC61000-4-4
SURGE	Line to line : $\pm 1KV$ (peak)	IEC61000-4-5
	Line to earth (ground) : $\pm 2KV$ (peak)	

### 7-2 EMI for both Conduction & Radiation ( At Resistor load )

<b>Comply with Standards</b>
CISPR22 ; EN55022, Class B

## 8. MECHANICAL CHARACTERISTICS.

8-1 Physical Size : 75mm(L) x 50mm(W) x 30mm(H)

8-2 Enclosure material : 94V-1, minimum

8-3 Output Cable : 700mm 電話線 #26 x4C (客戶提供) , with Plug : RJ11 Phone jack

Polarity : As figure show

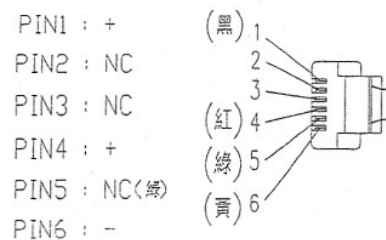

8-4 Strain Relief Test :

9 Kg to the output cord for 60 seconds each , there should be no breakage of the cord or plug .

8-5 Vibration Test :

The vibration frequencies are set at 10-55-10 Hz. with total amplitude of 1.5 mm along the 3 directions namely X-Y-Z. The each direction should be vibrated for 30 minutes, after testing no abnormal electrical or mechanical should occur.

8-6 Drop Test : (Referring to CSA C22.2 No.950 / UL1950 / UL1310 / EN60950)

Products shall be dropped from a height of 1M onto a horizontal surface consists of hardwood at 13mm thick, mounted on two layers of plywood each 19mm to 20mm thick, all supported on a concrete or equivalent non-resilient floor.

Upon conclusion of test, the equipment need not be operational.

8-7 Cord Bending Test :

The cord shall withstand a weight of 200 gm, when swung from left to right at an angle of 120 deg. For testing total of 1000 times.

9. WARRANTY.

The products warrant for at least one year against defects in materials and workmanship.

10. Net Weight (Reference) : 81 ±5g

Tested By: Peter Wang

Checked By:



Approved By:





### Engineering Sample Electrical Testing Data

Customer :

Date: 2003/8/20

Part No. : SAL115A-1510U-6

Design No. : A6030152-2

ITEM	TEST SPEC.	Sample No.												
		1	2	3	4	5	6	7	8	9	10			
At 100Vac/50Hz No loading power	≤ 1 Watts (Max.)	0.3												
Input Current At Full Load	400 mA (Max.)	176												
O/P DC-Voltage At Load 0 mA	13.6±5% Vdc	13.6												
O/P DC-Voltage At Load 600 mA	13.6±5% Vdc	13.4												
Ripple & Noise At full Load	150 mVp-p	18												
Efficiency	80%	84%												
Over Load Current	1.5 ~ 3.5	2.0												
At 240Vac/50Hz No loading power	≤ 1 Watts (Max.)	0.4												
Input Current At Full Load	135 mA (Max.)	85												
O/P DC-Voltage At Load 0 mA	13.6±5% Vdc	13.6												
O/P DC-Voltage At Load 600 mA	13.6±5% Vdc	13.4												
Ripple & Noise At full Load	150 mVp-p	15												
Efficiency	75%	81%												
Over Load Current	1.5 ~ 3.5	2.2												

**Remark :**

Output ripple and noise are measured by oscilloscope (20MHz bandwidth ) and output in parallel with one 10uF/50V and one 0.1uF/50V capacitor



## 15W AC to DC Switching Power Adapter Specification

Model Name : SAL115A-1510U-6

### INDEX

1.) Electrical Specification

2.) Mechanical Drawing

3.) Temperature Test

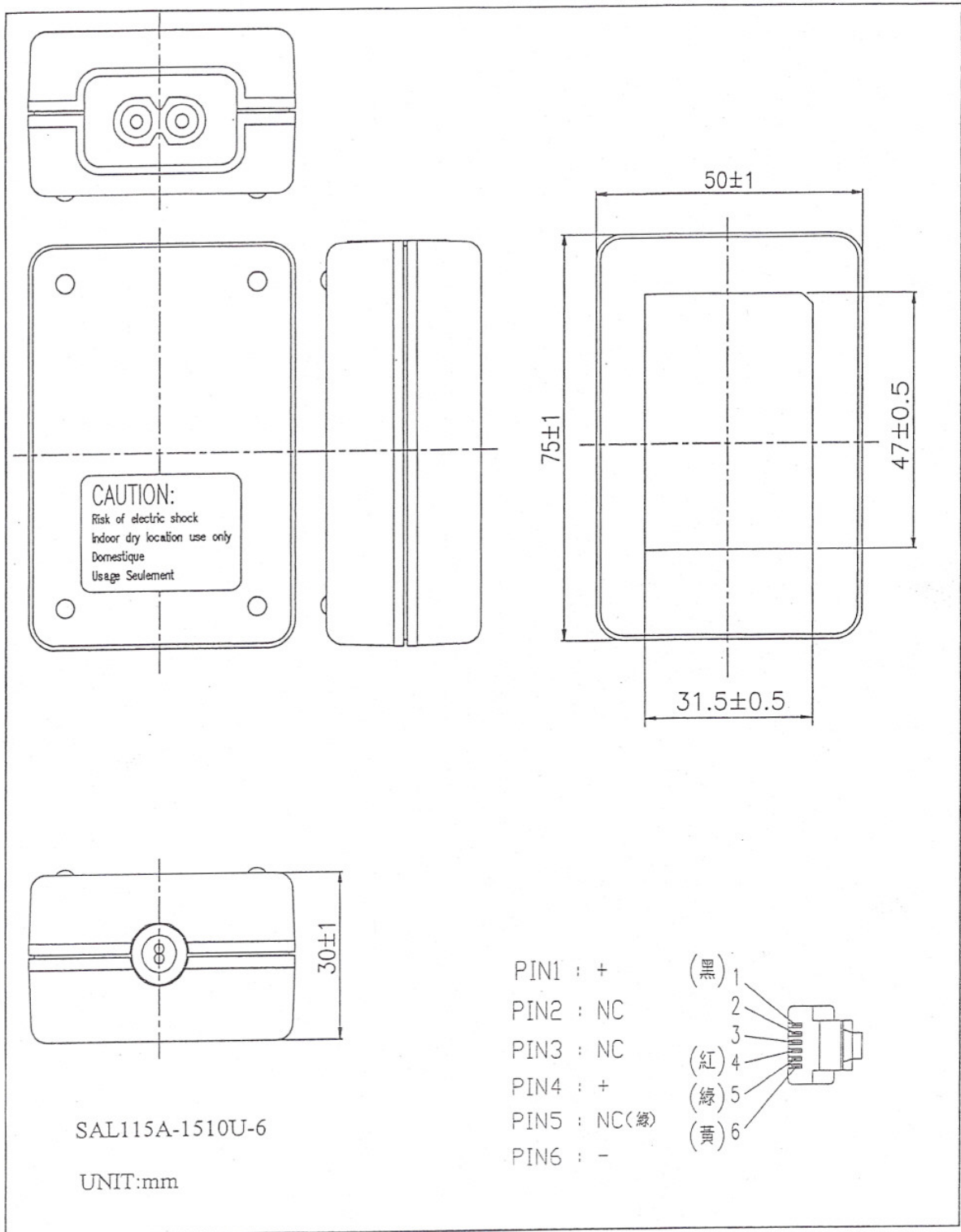

PIN1 : +  
 PIN2 : NC  
 PIN3 : NC  
 PIN4 : +  
 PIN5 : NC(綠)  
 PIN6 : -

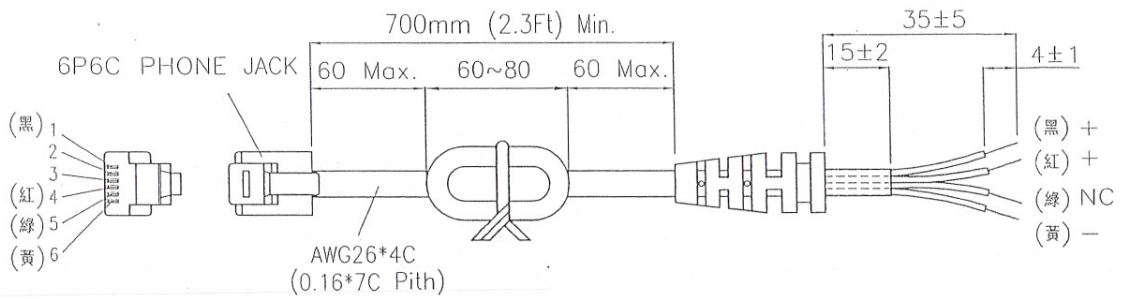

△						DATE\REVISER		DWG. NAME	DC CORD	
REV.	DESCRIPTION					DATE\REVISER		MODEL		
DRAWER	DESIGN	CHECK	APPROVED	DIMENSION	TOLERANCE	Q'TY	UNIT	MATERIAL	P. V. C.	
CHENG	 92.8.20 美智	 92.8.20 大同	 90.8.20 介超	0 ~ 5	±0.1	UNIT	mm	TREATMENT		
				5 ~ 60	±0.2	SCALE	/	DWG. NO.	89-TEI-8	
				60 ~ 200	±0.3	ORIG. DATE	2003.7.8	ONTOP COMPANY LIMITED		
				200 ~ 350	±0.6	MANUFACTORY				



## 15W AC to DC Switching Power Adapter Specification

Model Name : SAL115A-1510U-6

### INDEX

- 1.) Electrical Specification
- 2.) Mechanical Drawing
- 3.) Temperature Test