



ALL RIGHTS RESERVED. NO PORTION OF THIS PUBLICATION, WHETHER IN WHOLE OR IN PART CAN BE REPRODUCED WITHOUT THE EXPRESS WRITTEN CONSENT OF SPC TECHNOLOGY.

SPC-F005.DWG

REVISIONS

DOC. NO. SPC-F005 * Effective: 7/8/02 * DCP No: 1398

DCP #	REV	DESCRIPTION	DRAWN	DATE	CHECKD	DATE	APPRVD	DATE
1262	A	RELEASED	HO	8/21/01	JWM	8/21/02	DJC	8/21/02
1885	B	UPDATED TO ROHS COMPLIANCE	EO	02/03/06	HO	2/6/06	HO	2/6/06

Dimensions	A	B	C	D	E	F	G	H	I	J	K
Min.	8.5	7.74	6.09	0.40	-	2.41	4.82	0.71	0.73	12.7	42°
Max.	9.39	8.5	6.6	0.53	0.88	2.66	5.33	0.86	1.02	-	48°

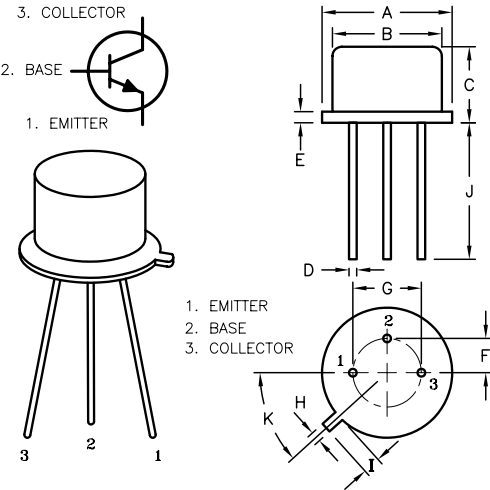

A silicon NPN transistor in a TO-39 type case designed primarily for amplifier and switching applications. This device features high breakdown voltage, low leakage current, low capacity, and beta useful over an extremely wide current range.

Electrical Characteristics: (T_A = +25°C Unless otherwise specified)

Parameter	Symbol	Test Conditions	Min	Typ	Max	Unit
OFF Characteristics						
Collector-Emitter Breakdown Voltage	V _{(BR)CEO}	I _C = 0.1mA, I _B = 0	40	-	-	V
Collector-Base Breakdown Voltage	V _{(BR)CBO}	I _C = 100µA, I _E = 0	60	-	-	V
Emitter-Base Breakdown Voltage	V _{(BR)EBO}	I _E = 100µA, I _C = 0	5	-	-	V
Emitter Cut-Off Current	I _{EBO}	V _{BE} = 4V, I _C = 0	-	-	0.25	µA

ON Characteristics, Note 1

DC Current Gain	h _{FE}	V _{CE} = 10V, I _C = 150mA	50	-	250	-
		V _{CE} = 2.5V, I _C = 150mA	40	-	-	-
Collector-Emitter Saturation Voltage	V _{CE(sat)}	I _C = 150mA, I _B = 15mA	-	-	1.4	V
Base-Emitter Saturation Voltage	V _{BE(sat)}	I _C = 150mA, I _B = 15mA	-	-	1.7	V

Small-Signal Characteristics

Current Gain-Bandwidth Product	f _T	V _{CE} = 10V, I _C = 50mA, f = 20MHz	100	-	-	MHz
Output Capacitance	C _{obo}	V _{CB} = 10V, I _E = 0, f = 1MHz	-	-	12	pF
Input Capacitance	C _{ibo}	V _{BE} = 500mV, I _C = 0, f = 1MHz	-	-	80	pF

Note 1. Pulse Test: Pulse Width ≤ 300µs, Duty Cycle ≤ 1%.

Absolute Maximum Ratings:

- Collector-Base Voltage, V_{CBO} = 60V
- Collector-Emitter Voltage, V_{CEO} = 40V
- Emitter-Base Voltage, V_{EBO} = 5V
- Continuous Collector Current, I_C = 0.7A
- Total Device Dissipation (T_A = +25°C), P_D = 800mW
Derate above 25°C = 4.6mW/°C
- Total Device Dissipation (T_C = +25°C), P_D = 5W
Derate above 25°C = 28.6mW/°C
- Operating Junction Temperature Range, T_J = -65° to +200°C
- Storage Temperature Range, T_{stg} = -65° to +200°C
- Thermal Resistance, Junction-to-Case, R_{thJC} = 35°C/W
- Lead Temperature (Duration Soldering, 1/16" from case, 60sec Max.), T_L = 300°C

DISCLAIMER:
ALL STATEMENTS AND TECHNICAL INFORMATION CONTAINED HEREIN ARE BASED UPON INFORMATION AND/OR TESTS WE BELIEVE TO BE ACCURATE AND RELIABLE. SINCE CONDITIONS OF USE ARE BEYOND OUR CONTROL, THE USER SHALL DETERMINE THE SUITABILITY OF THE PRODUCT FOR THE INTENDED USE AND ASSUME ALL RISK AND LIABILITY WHATSOEVER IN CONNECTION THEREWITH.

TOLERANCES:
UNLESS OTHERWISE SPECIFIED, DIMENSIONS ARE FOR REFERENCE PURPOSES ONLY.

DRAWN BY:	DATE:
HISHAM ODISH	8/21/02
CHECKED BY:	DATE:
JEFF MCVICKER	8/21/02
APPROVED BY:	DATE:
DANIEL CAREY	8/21/02

DRAWING TITLE: Amplifier Transistor, TO-39, NPN, Silicon			
SIZE	DWG. NO.	ELECTRONIC FILE	REV
A	2N3053	35C0698.DWG	B
SCALE:	NTS	U.O.M.: Millimeters	SHEET: 1 OF 1