

PNP Silicon Double Transistor

- To be used as a current mirror
- Good thermal coupling and V_{BE} matching
- High current gain
- Low collector-emitter saturation voltage

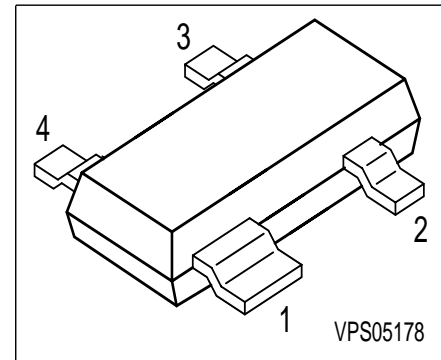
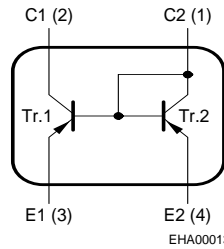

Type	Marking	Pin Configuration				Package
BCV62A	3Js	1 = C2	2 = C1	3 = E1	4 = E2	SOT143
BCV62B	3Ks	1 = C2	2 = C1	3 = E1	4 = E2	SOT143
BCV62C	3Ls	1 = C2	2 = C1	3 = E1	4 = E2	SOT143

Maximum Ratings

Parameter	Symbol	Value	Unit
Collector-emitter voltage (transistor T1)	V_{CEO}	30	V
Collector-base voltage (open emitter) (transistor T1)	V_{CBO}	30	
Emitter-base voltage	V_{EBS}	6	
DC collector current	I_C	100	mA
Peak collector current	I_{CM}	200	
Base peak current (transistor T1)	I_{BM}	200	
Total power dissipation, $T_S = 99\text{ °C}$	P_{tot}	300	mW
Junction temperature	T_j	150	°C
Storage temperature	T_{stg}	-65 ... 150	

Thermal Resistance

Junction - soldering point ¹⁾	R_{thJS}	≤170	K/W
--	------------	------	-----

¹⁾For calculation of R_{thJA} please refer to Application Note Thermal Resistance

Electrical Characteristics at $T_A = 25^\circ\text{C}$, unless otherwise specified

Parameter	Symbol	Values			Unit
		min.	typ.	max.	
DC Characteristics of T1					
Collector-emitter breakdown voltage $I_C = 10\text{ mA}, I_B = 0$	$V_{(BR)CEO}$	30	-	-	V
Collector-base breakdown voltage $I_C = 10\text{ }\mu\text{A}, I_B = 0$	$V_{(BR)CBO}$	30	-	-	
Emitter-base breakdown voltage $I_E = 10\text{ }\mu\text{A}, I_C = 0$	$V_{(BR)EBO}$	6	-	-	
Collector cutoff current $V_{CB} = 30\text{ V}, I_E = 0$	I_{CBO}	-	-	15	nA
Collector cutoff current $V_{CB} = 30\text{ V}, I_E = 0, T_A = 150\text{ }^\circ\text{C}$	I_{CBO}	-	-	5	μA
DC current gain 1) $I_C = 0.1\text{ mA}, V_{CE} = 5\text{ V}$	h_{FE}	100	-	-	-
DC current gain 1) $I_C = 2\text{ mA}, V_{CE} = 5\text{ V}$	h_{FE}				
	BCV62A	125	180	220	
	BCV62B	220	290	475	
	BCV62C	420	520	800	
Collector-emitter saturation voltage1) $I_C = 10\text{ mA}, I_B = 0.5\text{ mA}$ $I_C = 100\text{ mA}, I_B = 5\text{ mA}$	V_{CEsat}	-	75	300	mV
		-	250	650	
Base-emitter saturation voltage 1) $I_C = 10\text{ mA}, I_B = 0.5\text{ mA}$ $I_C = 100\text{ mA}, I_B = 5\text{ mA}$	V_{BEsat}	-	700	-	
		-	850	-	
Base-emitter voltage 1) $I_C = 2\text{ mA}, V_{CE} = 5\text{ V}$ $I_C = 10\text{ mA}, V_{CE} = 5\text{ V}$	$V_{BE(ON)}$	600	650	750	
		-	-	820	

 1) Pulse test: $t \leq 300\mu\text{s}$, $D = 2\%$

Electrical Characteristics at $T_A = 25^\circ\text{C}$, unless otherwise specified.

Parameter	Symbol	Values			Unit
		min.	typ.	max.	
DC Characteristics					
Base-emitter forward voltage $I_E = 10 \mu\text{A}$ $I_E = 250 \text{ mA}$	V_{BES}	0.4 -	- -	- 1.8	V
Matching of transistor T1 and transistor T2 at $I_{E2} = 0.5\text{mA}$ and $V_{\text{CE1}} = 5\text{V}$ $T_A = 25^\circ\text{C}$ $T_A = 150^\circ\text{C}$	I_{C1} / I_{C2}	- 0.7 0.7	- - -	- 1.3 1.3	-
Thermal coupling of transistor T1 and transistor T2 1) T1: $V_{\text{CE}} = 5\text{V}$ Maximum current of thermal stability of I_{C1}	I_{E2}	-	5	-	mA
AC characteristics of transistor T1					
Transition frequency $I_C = 10 \text{ mA}$, $V_{\text{CE}} = 5 \text{ V}$, $f = 100 \text{ MHz}$	f_T	-	250	-	MHz
Collector-base capacitance $V_{\text{CB}} = 10 \text{ V}$, $f = 1 \text{ MHz}$	C_{cb}	-	3	-	pF
Emitter-base capacitance $V_{\text{EB}} = 0.5 \text{ V}$, $f = 1 \text{ MHz}$	C_{eb}	-	8	-	
Noise figure $I_C = 200 \mu\text{A}$, $V_{\text{CE}} = 5 \text{ V}$, $R_S = 2 \text{ k}\Omega$, $f = 1 \text{ kHz}$, $\Delta f = 200 \text{ Hz}$	F	-	2	-	dB
Short-circuit input impedance $I_C = 1 \text{ mA}$, $V_{\text{CE}} = 10 \text{ V}$, $f = 1 \text{ kHz}$	h_{11e}	-	4.5	-	k Ω
Open-circuit reverse voltage transf.ratio $I_C = 1 \text{ mA}$, $V_{\text{CE}} = 10 \text{ V}$, $f = 1 \text{ kHz}$	h_{12e}	-	2	-	10^{-4}
Short-circuit forward current transf.ratio $I_C = 1 \text{ mA}$, $V_{\text{CE}} = 10 \text{ V}$, $f = 1 \text{ kHz}$	h_{21e}	100	-	900	-
Open-circuit output admittance $I_C = 1 \text{ mA}$, $V_{\text{CE}} = 10 \text{ V}$, $f = 1 \text{ kHz}$	h_{22e}	-	30	-	μS

1) Witout emitter resistor. Device mounted on alumina 15mm x 16.5mm x 0.7mm

Test circuit for current matching

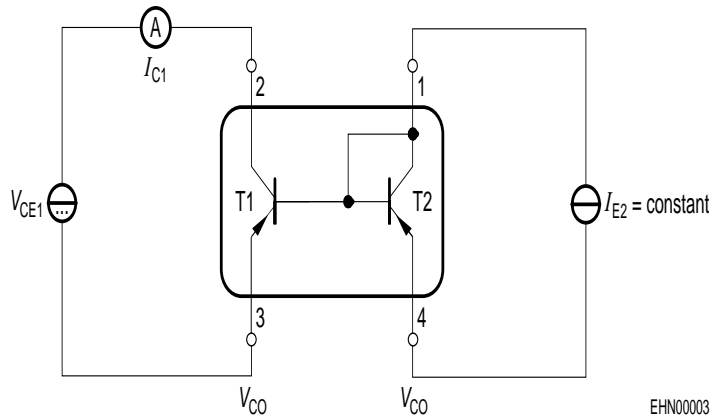

Note: Voltage drop at contacts: $V_{CO} < 2/3 V_T = 16\text{mV}$

Characteristic for determination of V_{CE1} at specified R_E range with I_{E2} as parameter under condition of $I_{C1}/I_{E2} = 1.3$

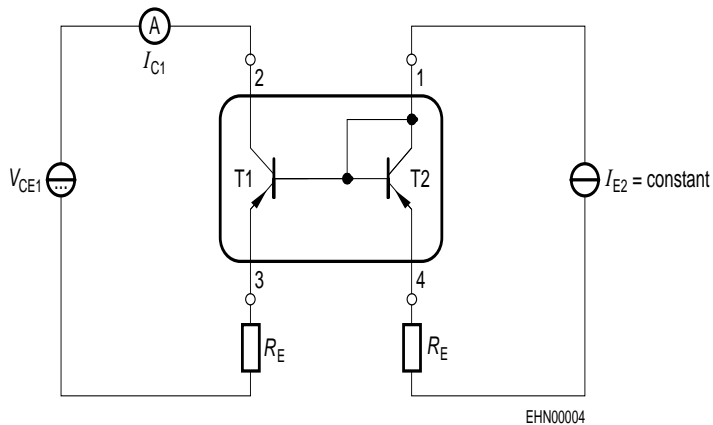

Note: BCV62 with emitter resistors

Total power dissipation $P_{tot} = f(T_S)$

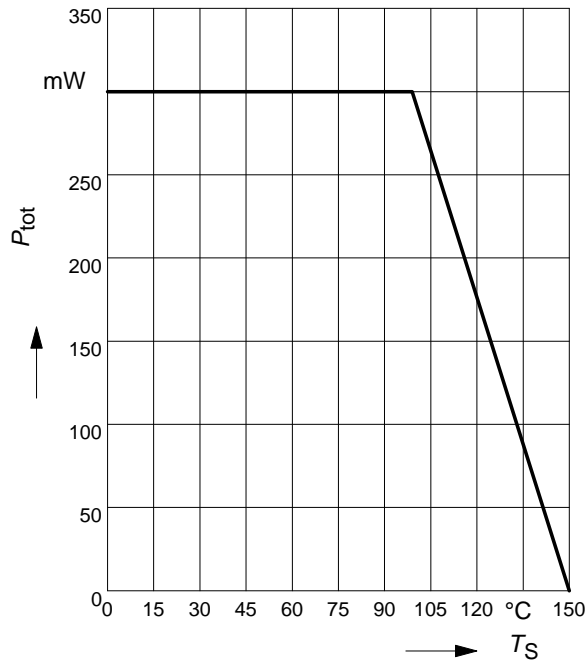

Permissible pulse load

$P_{totmax} / P_{totDC} = f(t_p)$

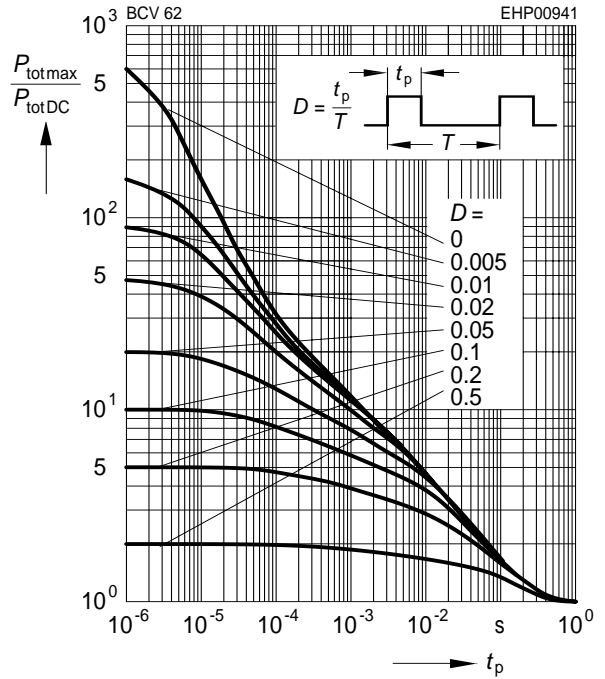

Package Outline

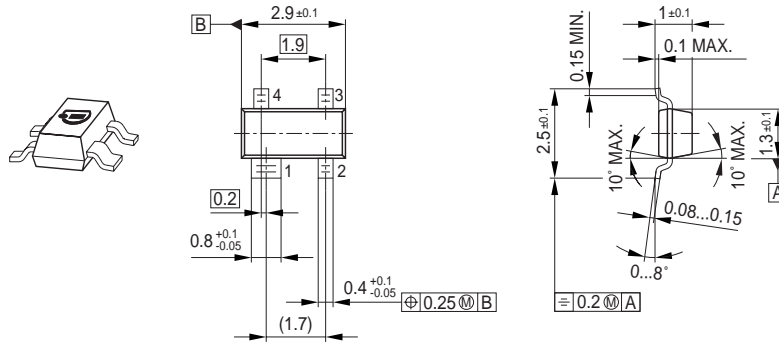

Foot Print

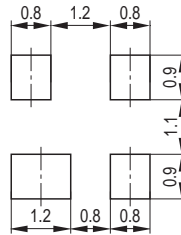

Marking Layout

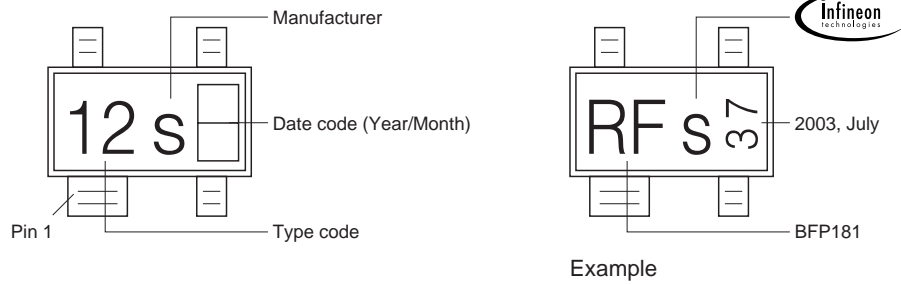

Packing

Code E6327: Reel ø180 mm = 3.000 Pieces/Reel
 Code E6433: Reel ø330 mm = 10.000 Pieces/Reel

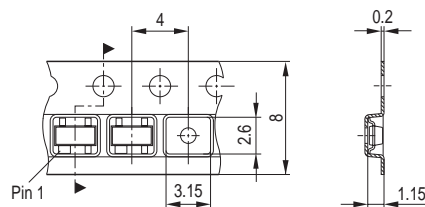

Published by Infineon Technologies AG,
St.-Martin-Strasse 53,
81669 München
© Infineon Technologies AG 2005.
All Rights Reserved.

Attention please!

The information herein is given to describe certain components and shall not be considered as a guarantee of characteristics.
Terms of delivery and rights to technical change reserved.
We hereby disclaim any and all warranties, including but not limited to warranties of non-infringement, regarding circuits, descriptions and charts stated herein.

Information

For further information on technology, delivery terms and conditions and prices please contact your nearest Infineon Technologies Office (www.infineon.com).

Warnings

Due to technical requirements components may contain dangerous substances. For information on the types in question please contact your nearest Infineon Technologies Office.
Infineon Technologies Components may only be used in life-support devices or systems with the express written approval of Infineon Technologies, if a failure of such components can reasonably be expected to cause the failure of that life-support device or system, or to affect the safety or effectiveness of that device or system. Life support devices or systems are intended to be implanted in the human body, or to support and/or maintain and sustain and/or protect human life. If they fail, it is reasonable to assume that the health of the user or other persons may be endangered.