

2N681 thru 2N692



SOLID STATE INC.

46 FARRAND STREET
BLOOMFIELD, NEW JERSEY 07003

www.solidstateinc.com

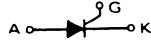

REVERSE BLOCKING TRIODE THYRISTORS

... designed primarily for half-wave ac control applications, such as motor controls, heating controls and power supplies; or wherever half-wave silicon gate-controlled, solid-state devices are needed.

- Glass Passivated Junctions and Center Gate Fire for Greater Parameter Uniformity and Stability
- Blocking Voltage to 800 Volts

SILICON CONTROLLED RECTIFIER

25 AMPERES RMS
25-800 VOLTS



TO-48

MAXIMUM RATINGS ($T_J = 125^\circ\text{C}$ unless otherwise noted.)

Rating	Symbol	Value	Unit
*Peak Repetitive Off-State Blocking Voltage (1) 2N681 2N682 2N683 2N684 2N685 2N686 2N687 2N688 2N689 2N690 2N691 2N692	V_{RRM} or V_{DRM}	25 50 100 150 200 250 300 400 500 600 700 800	Volts
*Peak Non-Repetitive Reverse Voltage 2N681 2N682 2N683 2N684 2N685 2N686 2N687 2N688 2N689 2N690 2N691 2N692	V_{RSM}	35 75 150 225 300 350 400 500 600 720 840 960	Volts
*RMS On-State Current (All Conduction Angles)	$I_T(RMS)$	25	Amp
*Average On-State Current ($T_C = 65^\circ\text{C}$)	$I_T(AV)$	16	Amp
*Peak Non-Repetitive Surge Current (One cycle, 60 Hz, preceded and followed by rated current and voltage)	I_{TSM}	150	Amp
Circuit Fusing Considerations ($T_J = -40$ to $+125^\circ\text{C}$, $t = 1.0$ to 8.3 ms)	I^2t	93	A^2s
*Peak Gate Power	P_{GM}	5.0	Watts
*Average Gate Power	$P_{G(AV)}$	0.5	Watt
*Peak Forward Gate Current 2N681-2N689 2N690-2N692	I_{GM}	2.0 1.2	Amp
*Peak Gate Voltage – Forward Reverse	V_{FGM} V_{RGM}	10 5.0	Volts
*Operating Junction Temperature Range	T_J	-65 to +125	$^\circ\text{C}$
*Storage Temperature Range	T_{stg}	-65 to +150	$^\circ\text{C}$
Stud Torque	–	30	in. lb.

2N681 thru 2N692

THERMAL CHARACTERISTICS

Characteristic	Symbol	Max	Unit
Thermal Resistance, Junction to Case	$R_{\theta JC}$	2.0	$^{\circ}\text{C}/\text{W}$

ELECTRICAL CHARACTERISTICS ($T_J = 25^{\circ}\text{C}$ unless otherwise noted.)

Characteristic	Symbol	Min	Typ	Max	Unit
*Average Forward or Reverse Blocking Current (Rated V_{DRM} or V_{RRM} , gate open, $T_J = 125^{\circ}\text{C}$)	$I_{D(AV)}, I_{R(AV)}$				mA
2N681-2N684		—	—	6.5	
2N685		—	—	6.0	
2N686		—	—	5.5	
2N687		—	—	5.0	
2N688		—	—	4.0	
2N689		—	—	3.0	
2N690		—	—	2.5	
2N691		—	—	2.25	
2N692		—	—	2.0	
Peak Forward or Reverse Blocking Current (Rated V_{DRM} or V_{RRM} , gate open, $T_J = 125^{\circ}\text{C}$)	I_{DRM}, I_{RRM}	—	—	2.0	mA
*Peak On-State Voltage ($I_{TM} = 50.3$ A peak, Pulse Width ≤ 1.0 ms, Duty Cycle $\leq 2.0\%$)	V_{TM}	—	—	2.0	Volts
Gate Trigger Current, Continuous dc ($V_{AK} = 12$ Vdc, $R_L = 50 \Omega$) *($V_{AK} = 12$ Vdc, $R_L = 50 \Omega, T_C = -65^{\circ}\text{C}$)	I_{GT}	—	—	40 80	mA
Gate Trigger Voltage, Continuous dc ($V_{AK} = 12$ Vdc, $R_L = 50 \Omega$) *($V_{AK} = 12$ Vdc, $R_L = 50 \Omega, T_J = -65^{\circ}\text{C}$)	V_{GT}	—	0.65	2.0 3.0	Volts
*Gate Non-Trigger Voltage (Rated V_{DRM} , $R_L = 50 \Omega, T_J = 125^{\circ}\text{C}$)	V_{GD}	0.25	—	—	Volts
Holding Current ($V_{AK} = 12$ Vdc, Gate Open)	I_H	—	7.3	50	mA
Critical Rate of Rise of Off-State Voltage (Rated V_{DRM} , Exponential Waveform, $T_J = 125^{\circ}\text{C}$, Gate Open)	dv/dt	—	30	—	$\text{V}/\mu\text{s}$

* Indicates JEDEC Registered Data.

FIGURE 1 – AVERAGE CURRENT DERATING

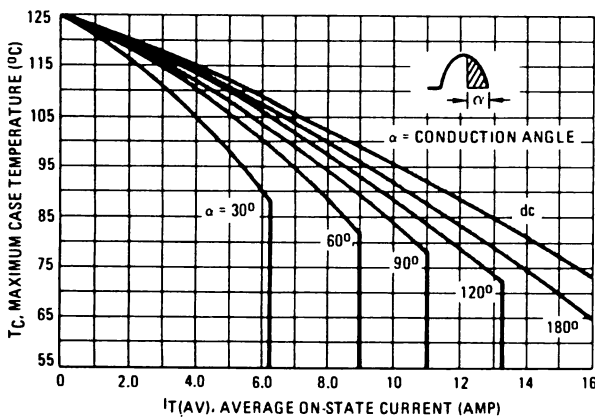
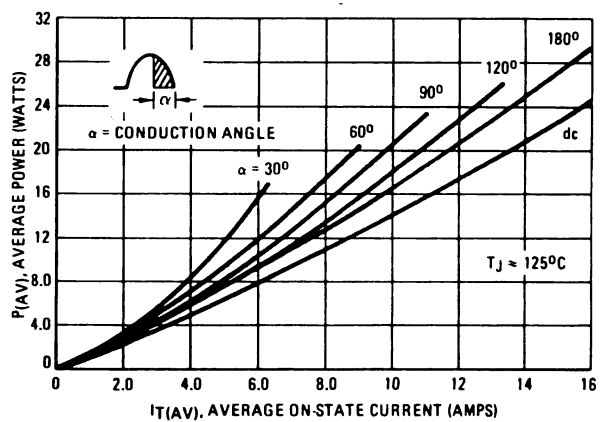

FIGURE 2 – MAXIMUM ON-STATE POWER DISSIPATION



2N681 thru 2N692

FIGURE 3 – ON-STATE CHARACTERISTICS

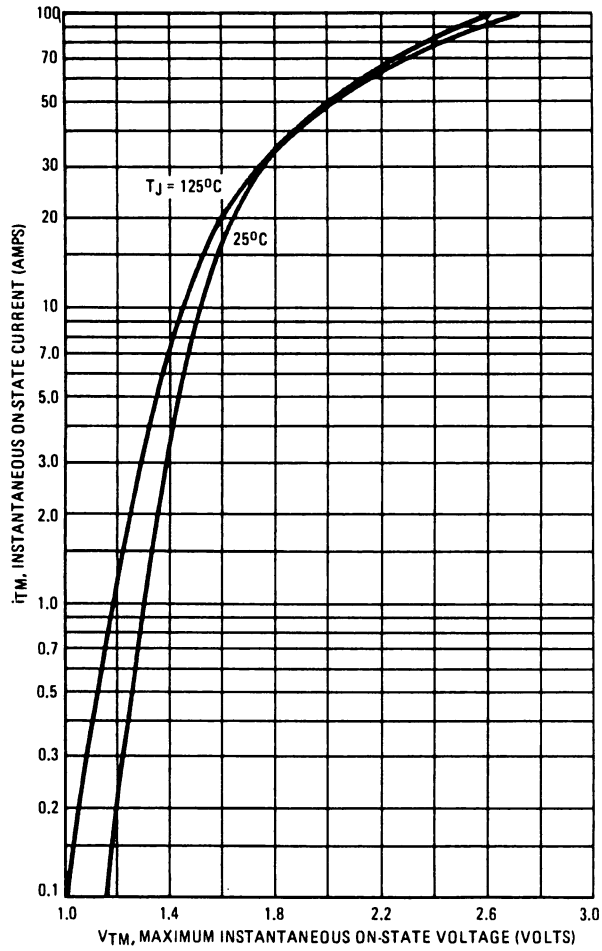

FIGURE 4 – MAXIMUM NON-REPETITIVE SURGE CURRENT

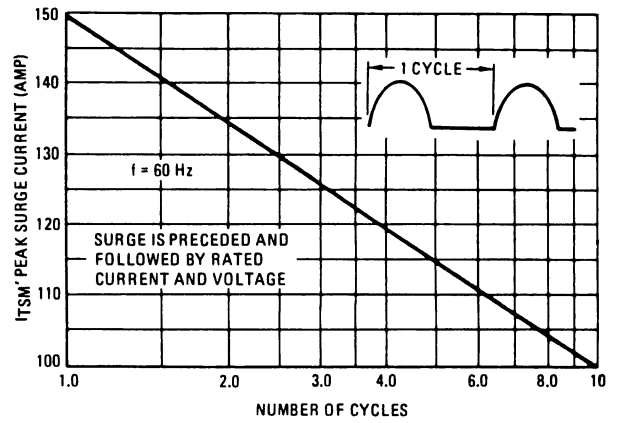
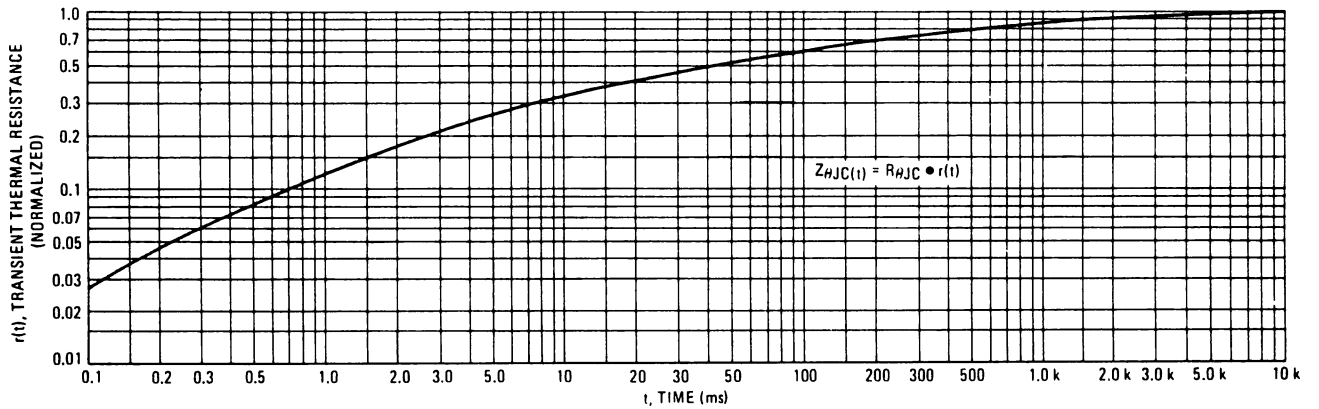

FIGURE 5 – THERMAL RESPONSE



TYPICAL CHARACTERISTICS

FIGURE 6 – PULSE TRIGGER CURRENT

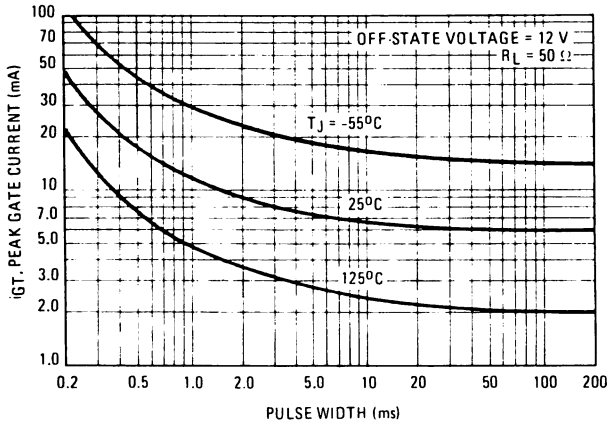

FIGURE 7 – GATE TRIGGER CURRENT

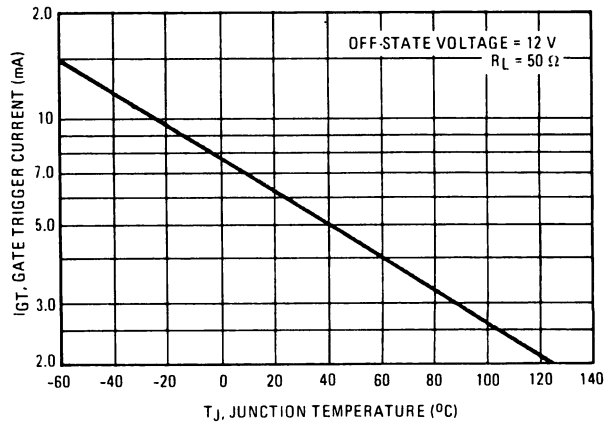

FIGURE 8 – GATE TRIGGER VOLTAGE

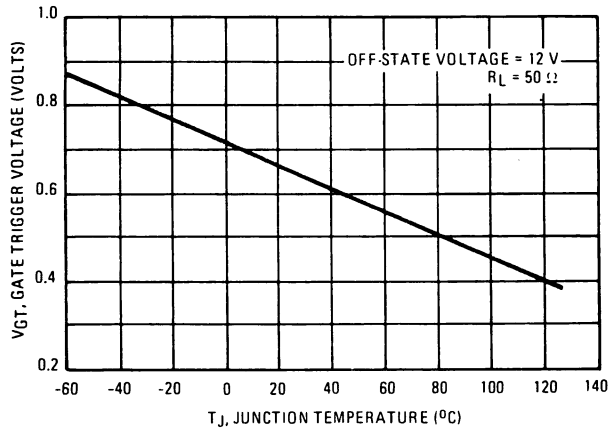
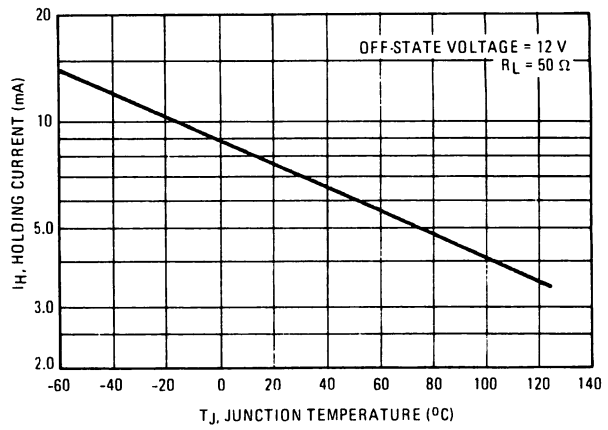
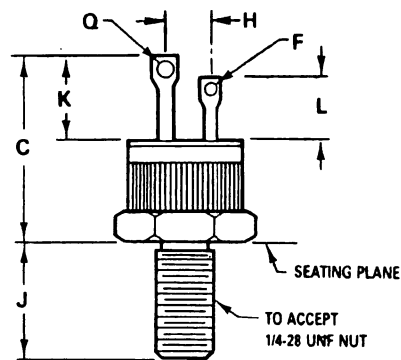
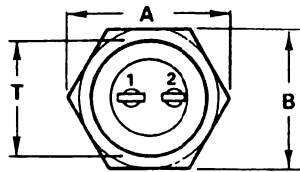

FIGURE 9 – HOLDING CURRENT





TERM. 1. CATHODE
 2. GATE
 STUD: ANODE

TO-48

DIM	MILLIMETERS		INCHES	
	MIN	MAX	MIN	MAX
A	15.34	15.60	0.604	0.614
B	14.00	14.20	0.551	0.559
C	20.70	24.13	0.815	0.950
F	0.89	2.16	0.035	0.085
H	3.75	4.41	0.148	0.174
J	10.67	11.56	0.420	0.455
K	9.78	10.54	0.385	0.416
L	6.99	7.75	0.275	0.305
Q	1.65	4.06	0.065	0.160
T	12.70	12.83	0.500	0.505