

Features

- Low cost!
- +4.75V to +5.5V input
- +2.5V (±25mV), 12 Amp output
- 200kHz, synchronous-rectifier topology
- High efficiency, 87%
- Low output noise, 40mVp-p
- Quick transient response, 30µsec
- -40 to +50°C operation with no derating
- Highly reliable, 100% SMT construction
- Remote on/off control
- Output short-circuit protection
- 1" x 2" metal package; EMC compliant
- IEC950/EN60950/UL1950 pending
- Modifications and customs for OEM's

As supply voltages trend lower and load currents increase, centralized power becomes more impractical. The tight accuracy, low noise and quick transient response demanded by today's low-voltage CPU's, ASIC's and DSP's make power processing at the "point of use" the only viable solution. As voltages decrease much below 3.3V, the task of designing your own circuit to efficiently derive low-voltage power from higher-voltage buses (5V, 12V, 48V, etc.) becomes significantly more challenging.

When you are designing power-hungry 2.5V partitions or boards, consider Murata Power Solutions' new UNR-2.5/12-D5. This non-isolated, 5V-to-2.5V DC/DC delivers a full 12 Amps at an impressive 87% efficiency. Packaged in a 1" x 2" x 0.44" metal case, the converter exploits synchronous rectification, planar magnetics and 100% automatic SMT assembly to bring you an incomparable 30 Watts of 2.5V power.

The UNR-2.5/12-D5 delivers full power over the -40 to +50°C temperature range without heat sinking or forced-air cooling. It is fully line (±0.1%) and load (±0.5%) regulated and features low noise (40mVp-p) and quick (30µsec) transient response. The unit offers remote on/off control, and it can withstand a sustained output short circuit with full recovery to rated accuracy.

Designing your own 2.5V step-down buck regulator may be practical for low-power applications. When you need 12 Amps, the task becomes significantly more time consuming. Consider that the high efficiency, ease-of-use, and overall cost effectiveness of Murata Power Solutions' new 2.5V UNR Series make the quick solution the best solution.

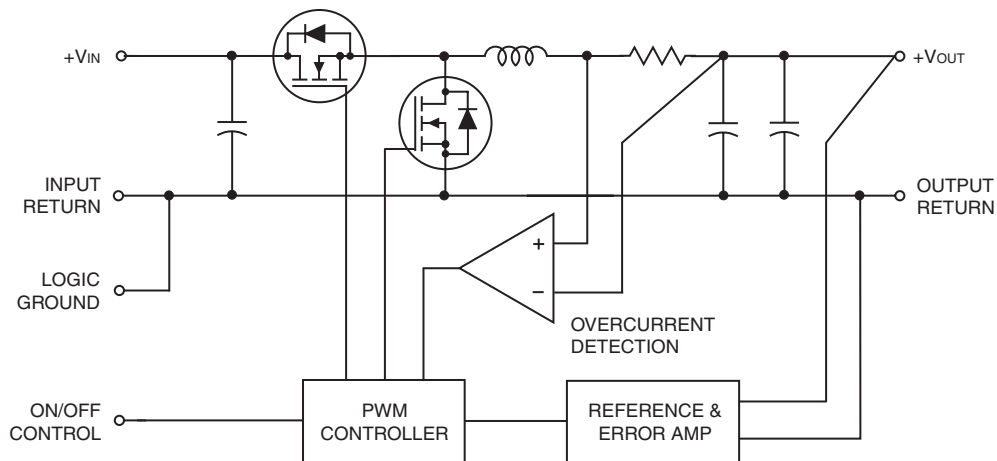

Signals applied to the On/Off Control are referenced to Logic Ground which is internally connected to Input/Output Return. The Logic Ground pin is not designed to carry heavy current. Do not install units with the Return pins open or connected via high-impedance runs.

Figure 1. Simplified Schematic



For full details go to
www.murata-ps.com/rohs

**Single Output, Non-Isolated, 5V-to-2.5V
12 Amp, DC/DC Converters**

Performance/Functional Specifications

Typical @ T_A = +25°C under nominal line voltage and full-load conditions unless noted. ① ②

| Input | |
|--------------------------------------|---|
| Input Voltage Range | 4.75-5.5 Volts (5V nominal) |
| Input Current ③ | 0.15/6.9 Amps |
| Input Filter Type | Capacitive |
| Overshoot Protection | None |
| Reverse-Polarity Protection | None |
| On/Off Control (Pin 2) ④ | TTL high (or open) = on, low = off |
| Output | |
| V _{out} Accuracy (50% load) | ±1% (±25mV) maximum |
| Temperature Coefficient | ±0.02% per °C |
| Ripple/Noise (20MHz BW) ⑤ | 40mVp-p typical, 80mVp-p maximum |
| Line/Load Regulation | ±0.1% maximum/±0.5% maximum |
| Efficiency | 87% typical, 84% minimum |
| Overcurrent Detection Point ⑥ | Auto-recovery |
| Dynamic Characteristics | |
| Transient Response (50% load step) | 30µsec to ±1% of final value |
| Switching Frequency | 200kHz (±20kHz) |
| Environmental | |
| Operating Temperature (Ambient): | |
| Without Derating | -40 to +50°C |
| With Derating | to +100°C (Straight line to 0 Watts) |
| Storage Temperature | -40 to +105°C |
| Physical | |
| Dimensions | 2" x 1" x 0.44" (51 x 25 x 11.2mm) |
| Shielding | 5-sided |
| Case Connection | Pin 5 (Input Return) |
| Case Material | Corrosion resistant steel with non-conductive, epoxy-based, black enamel finish and plastic baseplate |
| Pin Material | Tin over copper alloy |
| Weight | 1.6 ounces (45.4 grams) |

- ① These devices have no minimum load requirements and will regulate under no-load conditions.
- ② Achieving specified performance requires the installation of an external 470µF input capacitor with an ESR of 20mΩ and an rms ripple current rating of 6 Amps, as well as an external 22µF output capacitor with an ESR of 200mΩ or less.
- ③ No-load/full-load conditions. When the unit is off, the input "standby" current is typically 10mA.
- ④ See On/Off Control Functionality.
- ⑤ Output noise may be reduced by installing additional external capacitors across the output terminals. Caps should be selected for low ESR (typically 60mW) and located as close to the unit as possible.
- ⑥ Overcurrent detection initiates at approximately 30% above rated load, where the output current "hiccups" at an average current of 1A and remains there until the short is removed.

Absolute Maximum Ratings

| | |
|---------------------------------------|---|
| Input Voltage | 7 Volts |
| Output Current | Current limited. Devices can withstand a sustained output short circuit without damage. |
| Storage Temperature | -40 to +105°C |
| Lead Temperature (soldering, 10 sec.) | +300°C |

These are stress ratings. Exposure of devices to any of these conditions may adversely affect long-term reliability. Proper operation under conditions other than those listed in the Performance/Functional Specifications Table is not implied.

On/Off Control Functionality

The On/Off Control pin has an internal 5kΩ pull-up resistor to +V_{IN}. It can be driven with any logic circuit capable of meeting the following drive requirements. Logic "0" = 0 to +0.8V. Logic "1" = +2.0V to +V_{IN}. I_H (@ V_{IN} = +2.0V) = -0.7mA. I_L (@ V_{IN} = 0V) = -1.1mA. Open collector logic or a single NPN drive transistor can be used. The drive circuit should be rated for more than 5.5V. Applying a voltage to pin 2 when no input power is applied to the converter can cause permanent damage to the converter.

MECHANICAL SPECIFICATIONS

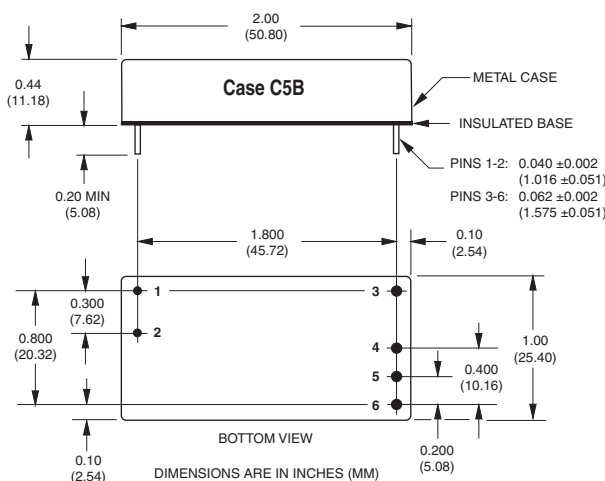

| I/O Connections | |
|-----------------|----------------|
| Pin | Function P9 |
| 1 | Logic Ground |
| 2 | On/Off Control |
| 3 | +Output |
| 4 | Output Return |
| 5 | Input Return |
| 6 | +Input |

Note:
The case is connected to pin 5 (Input Return).

ORDERING INFORMATION

UNR-2.5/12-D5 Non-Isolated, 5V-to-2.5V, 30 Watt, DC/DC Converter, non-RoHS.



Features

- Low cost!
- +4.75V to +5.5V input
- +3.3V (±33mV), 12 Amp output
- 200kHz, synchronous-rectifier topology
- High efficiency, 90%
- Low output noise, 40mVp-p
- Quick transient response, 30µsec
- -40 to +50°C operation with no derating
- Highly reliable, 100% SMT construction
- Remote on/off control
- Output short-circuit protection
- 1" x 2" metal package; EMC compliant
- IEC950/EN60950/UL1950 pending
- Modifications and customs for OEM'st

As 3.3V CPU's, DSP's and PLD's proliferate and low-voltage currents increase, the shortcomings of both traditional centralized power architectures and the recently introduced 3.3V outputs on AC/DC converters become more apparent. The solution is to locally derive 3.3V power from buses of higher voltage (5V, 12V, 48V, etc.). "Point-of-use" power processing is the only way to guarantee the tight accuracy, low noise, and quick transient response required by these new devices.

If you are designing power-hungry 3.3V partitions or boards, consider Murata Power Solutions' new UNR-3.3/12-D5. These non-isolated, 5V-to-3.3V DC/DC's deliver up to 12 Amps. Packaged in 1" x 2" x 0.44" metal cases, these converters use synchronous rectification, planar magnetics, and 100% automatic SMT assembly to bring you the most cost-effective 3.3V power.

The 90% efficient UNR-3.3/12-D5 delivers its full 40W output power from -40 to +50°C without heat sinking or forced-air cooling. It is fully line (±0.1% max.) and load (±0.5% max.) regulated and features a TTL-compatible on/off control. These devices can withstand a sustained output short circuit and automatically recover to rated accuracy.

Designing your own 3.3V step-down buck regulator may be practical for low-power applications. When you need 12 Amps, the task becomes significantly more challenging and time consuming. It's time to consider the high efficiency, ease-of-use, and overall cost effectiveness of Murata Power Solutions' UNR Series. Safety agency approvals and full EMI characterizations are currently in progress.

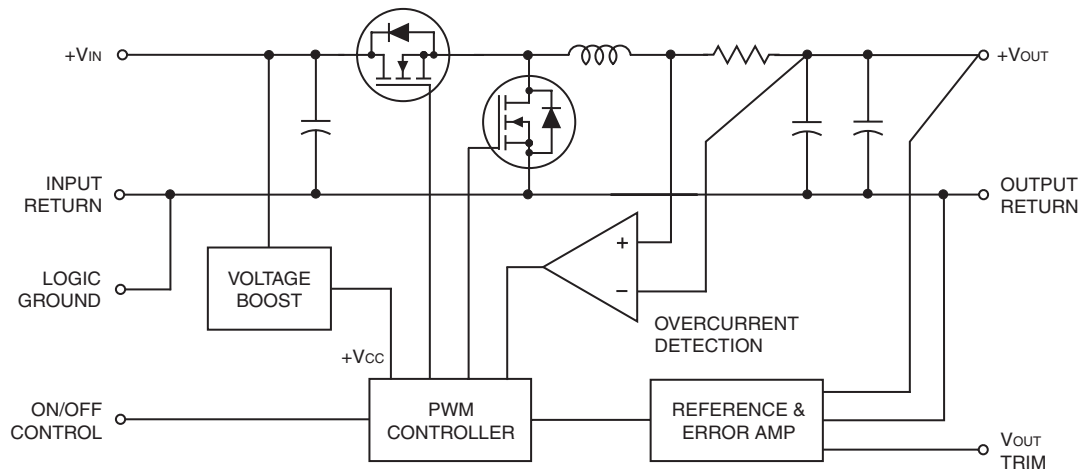

Signals applied to the On/Off Control are referenced to Logic Ground which is internally connected to Input/Output Return. The Logic Ground pin is not designed to carry heavy current. Do not install units with the Return pins open or connected via high-impedance runs.

Figure 2. Simplified Schematic

**Single Output, Non-Isolated, 5V-to-2.5V
12 Amp, DC/DC Converters**

Performance/Functional Specifications

Typical @ T_A = +25°C under nominal line voltage and full-load conditions unless noted. ① ②

| Input | |
|--------------------------------------|---|
| Input Voltage Range | 4.75-5.5 Volts (5V nominal) |
| Input Current ③ | 0.15/8.8 Amps |
| Input Filter Type | Capacitive |
| Overvoltage Protection | None |
| Reverse-Polarity Protection | None |
| On/Off Control (Pin 2) ④ | TTL high (or open) = on, low = off |
| Output | |
| V _{OUT} Accuracy (50% load) | ±1% (±33mV) maximum |
| Temperature Coefficient | ±0.02% per °C |
| Ripple/Noise (20MHz BW) ⑤ | 40mVp-p typical, 80mVp-p maximum |
| Line/Load Regulation | ±0.1% maximum/±0.5% maximum |
| Efficiency | 90% typical, 87% minimum |
| Overcurrent Detection Point ⑥ | Auto-recovery |
| Dynamic Characteristics | |
| Transient Response (50% load step) | 30µsec to ±1% of final value |
| Switching Frequency | 200kHz (±20kHz) |
| Environmental | |
| Operating Temperature (Ambient): | |
| Without Derating | -40 to +50°C |
| With Derating | to +100°C (Straight line to 0 Watts) |
| Storage Temperature | -40 to +105°C |
| Physical | |
| Dimensions | 2" x 1" x 0.44" (51 x 25 x 11.2mm) |
| Shielding | 5-sided |
| Case Connection | Pin 5 (Input Return) |
| Case Material | Corrosion resistant steel with non-conductive, epoxy-based, black enamel finish and plastic baseplate |
| Pin Material | RoHS: Gold-plate over copper alloy Non-RoHS: Tin over copper alloy |
| Weight | 1.6 ounces (45.4 grams) |

- ① These devices have no minimum load requirements and will regulate under no-load conditions.
- ② Achieving specified performance requires the installation of an external 470µF input capacitor with an ESR of 20mΩ and an rms ripple current rating of 6 Amps, as well as an external 22µF output capacitor with an ESR of 200mΩ or less.
- ③ No-load/full-load conditions. When the unit is off, the input "standby" current is typically 10mA.
- ④ See On/Off Control Functionality.
- ⑤ Output noise may be reduced by installing additional external capacitors across the output terminals. Caps should be selected for low ESR (typically 60mΩ) and located as close to the unit as possible.
- ⑥ Overcurrent detection initiates at approximately 30% above rated load, where the output current "hiccupps" at an average current of 1A and remains there until the short is removed.

| Absolute Maximum Ratings | |
|---------------------------------------|---|
| Input Voltage | 7 Volts |
| Output Current | Current limited. Devices can withstand a sustained output short circuit without damage. |
| Storage Temperature | -40 to +105°C |
| Lead Temperature (soldering, 10 sec.) | +300°C |

These are stress ratings. Exposure of devices to any of these conditions may adversely affect long-term reliability. Proper operation under conditions other than those listed in the Performance/Functional Specifications Table is not implied.

On/Off Control Functionality

The On/Off Control pin has an internal 5kΩ pull-up resistor to +V_{IN}. It can be driven with any logic circuit capable of meeting the following drive requirements. Logic "0" = 0 to +0.8V. Logic "1" = +2.0V to +V_{IN}. I_{IH} (@V_{IN} = +2.0V) = -0.7mA. I_{IL} (@V_{IN} = 0V) = -1.1mA. Open collector logic or a single NPN drive transistor can be used. The drive circuit should be rated for more than 5.5V. Applying a voltage to pin 2 when no input power is applied to the converter can cause permanent damage to the converter.

MECHANICAL SPECIFICATIONS

| I/O Connections | |
|-----------------|----------------|
| Pin | Function P9 |
| 1 | Logic Ground |
| 2 | On/Off Control |
| 3 | +Output |
| 4 | Output Return |
| 5 | Input Return |
| 6 | +Input |

Note: The case is connected to pin 5 (Input Return).

ORDERING INFORMATION

| | |
|-----------------|--|
| UNR-3.3/12-D5 | Non-Isolated, 5V-to-3.3V, 40 Watt, DC/DC Converter, non-RoHS version |
| UNR-3.3/12-D5-C | RoHS version |

Murata Power Solutions, Inc.
11 Cabot Boulevard, Mansfield, MA 02048-1151 U.S.A.
Tel: (508) 339-3000 (800) 233-2765 Fax: (508) 339-6356
www.murata-ps.com email: sales@murata-ps.com ISO 9001 REGISTERED

Murata Power Solutions, Inc. makes no representation that the use of its products in the circuits described herein, or the use of other technical information contained herein, will not infringe upon existing or future patent rights. The descriptions contained herein do not imply the granting of licenses to make, use, or sell equipment constructed in accordance therewith. Specifications are subject to change without notice. © 2008 Murata Power Solutions, Inc.

04/10/08

- USA:** Mansfield (MA), Tel: (508) 339-3000, email: sales@murata-ps.com
- Canada:** Toronto, Tel: (866) 740-1232, email: toronto@murata-ps.com
- UK:** Milton Keynes, Tel: +44 (0)1908 615232, email: mk@murata-ps.com
- France:** Montigny Le Bretonneux, Tel: +33 (0)1 34 60 01 01, email: france@murata-ps.com
- Germany:** München, Tel: +49 (0)89-544334-0, email: munich@murata-ps.com
- Japan:** Tokyo, Tel: 3-3779-1031, email: sales_tokyo@murata-ps.com
Osaka, Tel: 6-6354-2025, email: sales_osaka@murata-ps.com
Website: www.murata-ps.jp
- China:** Shanghai, Tel: +86 215 027 3678, email: shanghai@murata-ps.com
Guangzhou, Tel: +86 208 221 8066, email: guangzhou@murata-ps.com