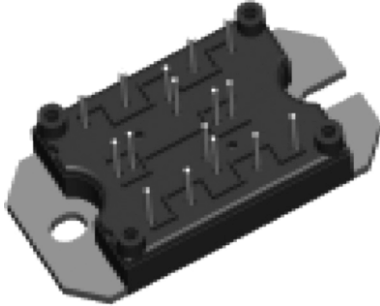



"Full Bridge" IGBT MTP (Warp Speed IGBT), 50 A


MTP

PRODUCT SUMMARY	
V_{CES}	600 V
I_C DC	69 A
$V_{CE(on)}$	2.22 V

FEATURES

- Generation 4 warp speed IGBT technology
- HEXFRED® antiparallel diodes with ultrasoft reverse recovery
- Very low conduction and switching losses
- Optional SMT thermistor
- Al_2O_3 DBC
- Very low stray inductance design for high speed operation
- Speed 8 kHz to 60 kHz > 20 kHz hard switching, > 200 kHz resonant mode
- UL approved file E78996 
- Compliant to RoHS directive 2002/95/EC
- Designed and qualified for industrial level


RoHS
COMPLIANT

BENEFITS

- Optimized for welding, UPS and SMPS applications
- Low EMI, requires less snubbing
- Direct mounting to heatsink
- PCB solderable terminals
- Very low junction to case thermal resistance

ABSOLUTE MAXIMUM RATINGS				
PARAMETER	SYMBOL	TEST CONDITIONS	MAX.	UNITS
Collector to emitter voltage	V_{CES}		600	V
Continuous collector current	I_C	$T_C = 25\text{ }^\circ\text{C}$	69	A
		$T_C = 80\text{ }^\circ\text{C}$	46	
Pulsed collector current	I_{CM}		200	
Peak switching current	I_{LM}		200	
Diode continuous forward current	I_F	$T_C = 100\text{ }^\circ\text{C}$	25	
Peak diode forward current	I_{FM}		200	
Gate to emitter voltage	V_{GE}		± 20	V
RMS isolation voltage	V_{ISOL}	Any terminal to case, $t = 1$ minute	2500	
Maximum power dissipation per single IGBT	P_D	$T_C = 25\text{ }^\circ\text{C}$	195	W
		$T_C = 100\text{ }^\circ\text{C}$	78	

ELECTRICAL SPECIFICATIONS ($T_J = 25\text{ }^\circ\text{C}$ unless otherwise noted)						
PARAMETER	SYMBOL	TEST CONDITIONS	MIN.	TYP.	MAX.	UNITS
Collector to emitter breakdown voltage	$V_{(BR)CES}$	$V_{GE} = 0\text{ V}$, $I_C = 250\text{ }\mu\text{A}$	600	-	-	V
Temperature coefficient of breakdown voltage	$\Delta V_{(BR)CES}/\Delta T_J$	$V_{GE} = 0\text{ V}$, $I_C = 4\text{ mA}$ (25 °C to 125 °C)	-	+ 0.6	-	V/°C
Collector to emitter saturation voltage	$V_{CE(on)}$	$V_{GE} = 15\text{ V}$, $I_C = 25\text{ A}$	-	2.22	3.14	V
		$V_{GE} = 15\text{ V}$, $I_C = 50\text{ A}$	-	2.43	3.25	
		$V_{GE} = 15\text{ V}$, $I_C = 25\text{ A}$, $T_J = 150\text{ }^\circ\text{C}$	-	1.65	1.93	
		$V_{GE} = 15\text{ V}$, $I_C = 50\text{ A}$, $T_J = 150\text{ }^\circ\text{C}$	-	2.08	2.45	
Gate threshold voltage	$V_{GE(th)}$	$V_{CE} = V_{GE}$, $I_C = 250\text{ }\mu\text{A}$	3	-	6	
Temperature coefficient of threshold voltage	$\Delta V_{GE(th)}/\Delta T_J$	$V_{CE} = V_{GE}$, $I_C = 250\text{ }\mu\text{A}$ (25 °C to 125 °C)	-	- 17	-	mV/°C
Transconductance	g_{fe}	$V_{CE} = 100\text{ V}$, $I_C = 25\text{ A}$, $PW = 80\text{ }\mu\text{s}$	-	43	-	S
Zero gate voltage collector current	$I_{CES} (1)$	$V_{GE} = 0\text{ V}$, $V_{CE} = 600\text{ V}$, $T_J = 25\text{ }^\circ\text{C}$	-	-	250	μA
		$V_{GE} = 0\text{ V}$, $V_{CE} = 600\text{ V}$, $T_J = 150\text{ }^\circ\text{C}$	-	-	10	mA
Gate to emitter leakage current	I_{GES}	$V_{GE} = \pm 20\text{ V}$	-	-	± 250	nA
Diode forward voltage drop	V_{FM}	$I_C = 25\text{ A}$	-	1.36	1.64	V
		$I_C = 50\text{ A}$	-	1.57	1.93	
		$I_C = 25\text{ A}$; $T_J = 150\text{ }^\circ\text{C}$	-	1.19	1.42	
		$I_C = 50\text{ A}$; $T_J = 150\text{ }^\circ\text{C}$	-	1.48	1.80	

Note

(1) I_{CES} includes also opposite leg overall leakage

SWITCHING CHARACTERISTICS ($T_J = 25\text{ }^\circ\text{C}$ unless otherwise specified)						
PARAMETER	SYMBOL	TEST CONDITIONS	MIN.	TYP.	MAX.	UNITS
Total gate charge (turn-on)	Q_g	$I_C = 25\text{ A}$ $V_{CC} = 480\text{ V}$ $V_{GE} = 15\text{ V}$	-	175	263	nC
Gate to emitter charge (turn-on)	Q_{ge}		-	27	41	
Gate to collector charge (turn-on)	Q_{gc}		-	71	107	
Turn-on switching loss	E_{on}	$R_g = 5\text{ }\Omega$, $I_C = 25\text{ A}$ $V_{CC} = 480\text{ V}$ $V_{GE} = \pm 15\text{ V}$, $T_J = 25\text{ }^\circ\text{C}$	-	0.13	0.20	mJ
Turn-off switching loss	E_{off}		-	0.42	0.62	
Total switching loss	E_{tot}		-	0.55	0.82	
Turn-on switching loss	E_{on}	$R_g = 5\text{ }\Omega$, $I_C = 25\text{ A}$ $V_{CC} = 480\text{ V}$ $V_{GE} = \pm 15\text{ V}$, $T_J = 125\text{ }^\circ\text{C}$	-	0.39	0.59	
Turn-off switching loss	E_{off}		-	0.49	0.74	
Total switching loss	E_{tot}		-	0.88	1.32	
Input capacitance	C_{ies}	$V_{GE} = 0\text{ V}$ $V_{CC} = 30\text{ V}$ $f = 1.0\text{ MHz}$	-	3610	5415	pF
Output capacitance	C_{oes}		-	714	1071	
Reverse transfer capacitance	C_{res}		-	58	87	
Diode reverse recovery time	t_{rr}	$V_R = 200\text{ V}$; $I_C = 25\text{ A}$; $di/dt = 200\text{ A}/\mu\text{s}$	-	50	-	ns
Diode peak reverse current	I_{rr}		-	4.5	-	A
Diode Recovery charge	Q_{rr}		-	112	-	nC
Diode peak rate of fall of recovery during t_b	$di_{(rec)}/dt$		-	250	-	A/ μs

THERMAL AND MECHANICAL SPECIFICATIONS						
PARAMETER	SYMBOL	TEST CONDITIONS	MIN.	TYP.	MAX.	UNITS
Operating junction temperature range	T_J		- 40	-	150	°C
Storage temperature range	T_{Stg}		- 40	-	125	
Junction to case	IGBT	R_{thJC}	-	-	0.64	°C/W
	Diode		-	-	0.9	
Case to sink per module	R_{thCS}	Heatsink compound thermal conductivity = 1 W/mK	-	0.06	-	
Clearance ⁽¹⁾		External shortest distance in air between 2 terminals	5.5	-	-	mm
Creepage ⁽¹⁾		Shortest distance along external surface of the insulating material between 2 terminals	8	-	-	
Weight			66			g

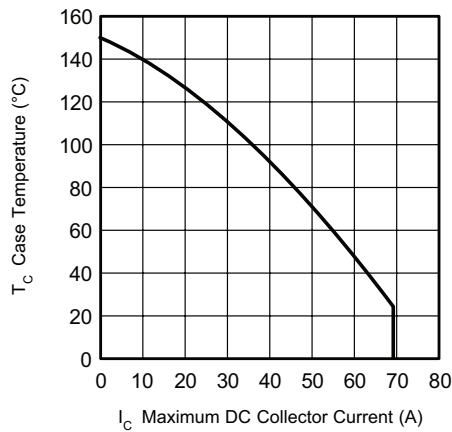
Note
⁽¹⁾ Standard version only i.e. without optional thermistor


Fig. 1 - Maximum Collector Current vs. Case Temperature

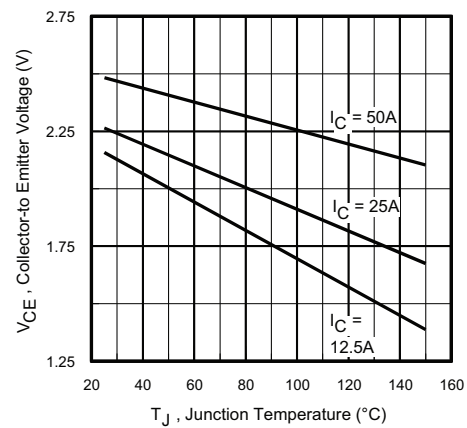


Fig. 2 - Typical Collector to Emitter Voltage vs. Junction Temperature

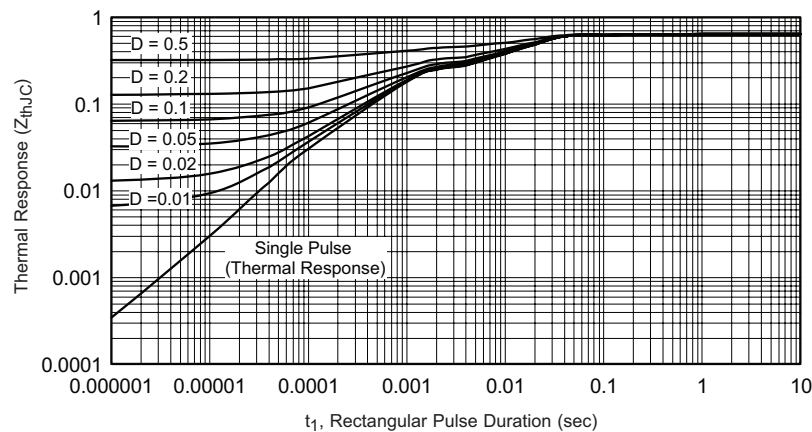


Fig. 3 - Maximum Transient Thermal Impedance, Junction to Case (IGBT)

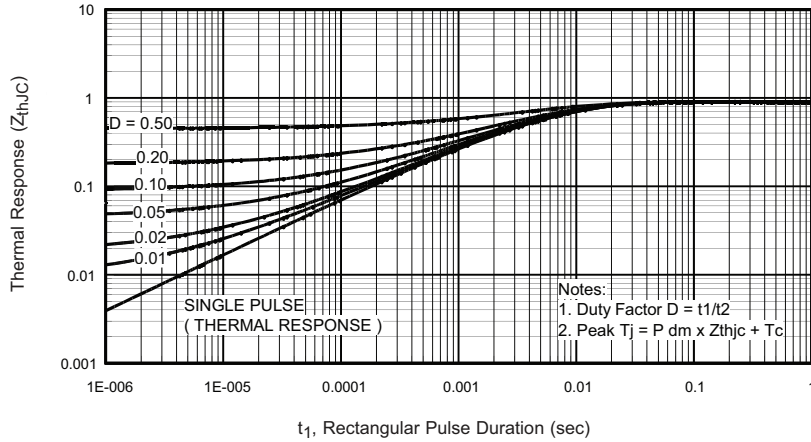


Fig. 4 - Maximum Transient Thermal Impedance, Junction to Case (Diode)

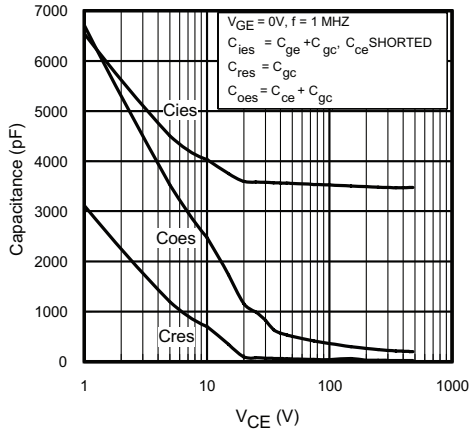


Fig. 5 - Typical Capacitance vs. Collector to Emitter Voltage

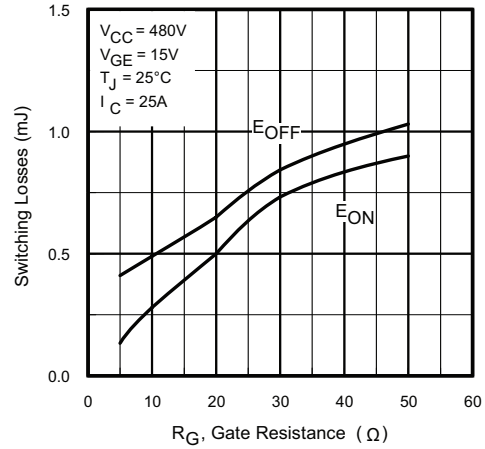


Fig. 7 - Typical Switching Losses vs. Gate Resistance

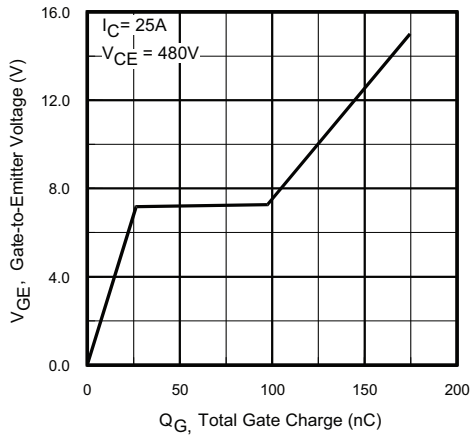


Fig. 6 - Typical Gate Charge vs. Gate to Emitter Voltage

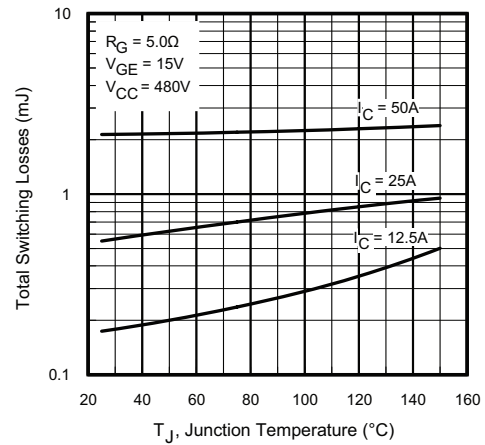


Fig. 8 - Typical Switching Losses vs. Junction Temperature

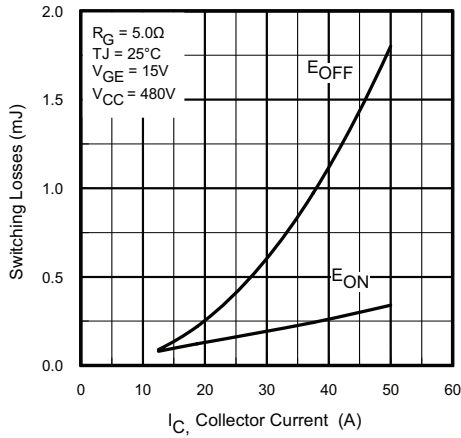


Fig. 9 - Typical Switching Losses vs. Collector to Emitter Current

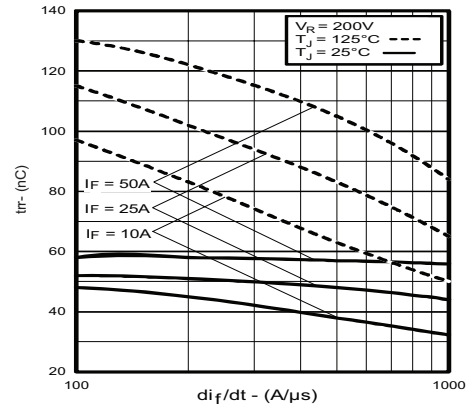
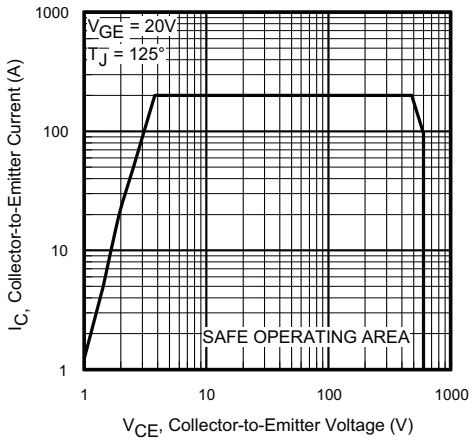

 Fig. 12 - Typical Reverse Recovery Time vs. dI_F/dt


Fig. 10 - Turn-Off SOA

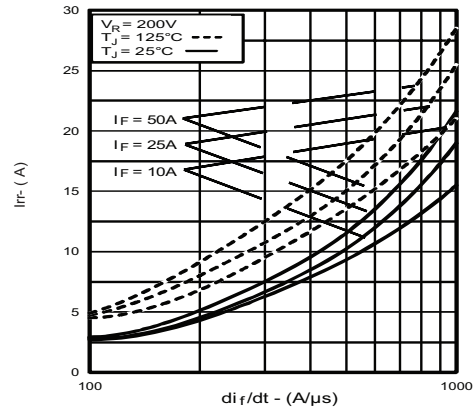
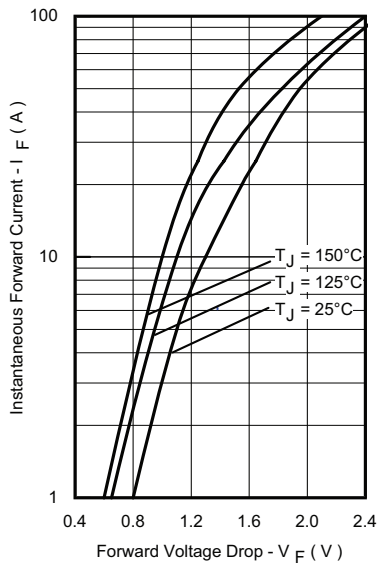
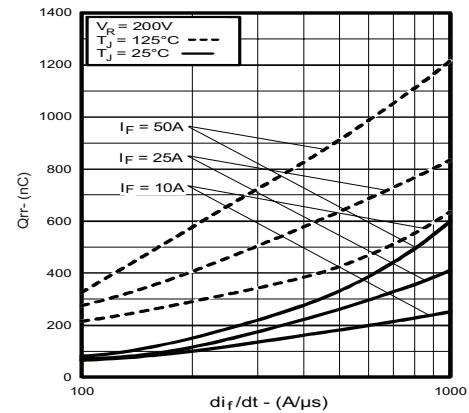

 Fig. 13 - Typical Reverse Recovery Current vs. dI_F/dt


Fig. 11 - Maximum Forward Voltage Drop vs. Instantaneous Forward Current


 Fig. 14 - Typical Stored Charge vs. dI_F/dt

25MT060WFAPbF



Vishay High Power Products "Full Bridge" IGBT MTP
(Warp Speed IGBT), 50 A

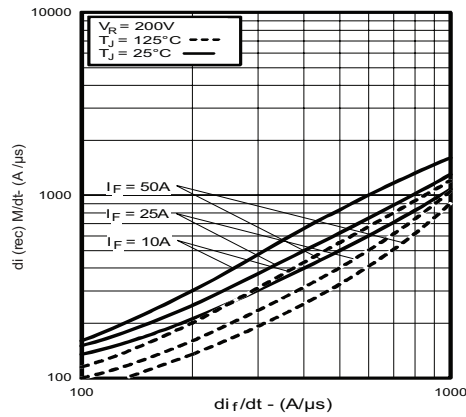


Fig. 15 - Typical $dI_{(rec)M}/dt$ vs. dI_F/dt

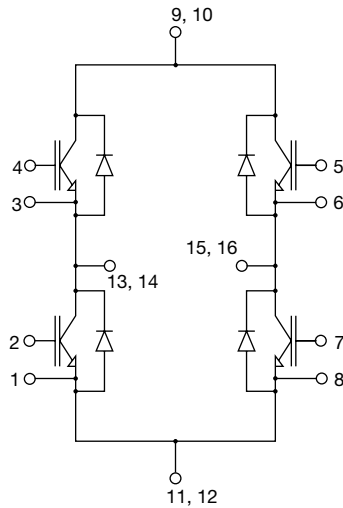


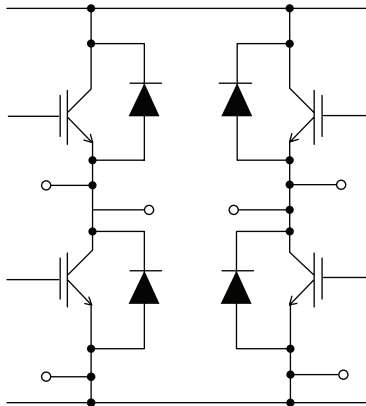
Fig. 16 - Electrical diagram

ORDERING INFORMATION TABLE

Device code	25	MT	060	W	F	A	PbF
	①	②	③	④	⑤	⑥	⑦

- 1** - Current rating (25 = 25 A)
- 2** - Essential part number
- 3** - Voltage code (060 = 600 V)
- 4** - Speed/type (W = Warp IGBT)
- 5** - Circuit configuration (F = Full bridge)
- 6** - A = Al₂O₃ DBC substrate
- 7** - PbF = Lead (Pb)-free

CIRCUIT CONFIGURATION



LINKS TO RELATED DOCUMENTS

Dimensions	www.vishay.com/doc?95245
------------	--



Disclaimer

ALL PRODUCT, PRODUCT SPECIFICATIONS AND DATA ARE SUBJECT TO CHANGE WITHOUT NOTICE TO IMPROVE RELIABILITY, FUNCTION OR DESIGN OR OTHERWISE.

Vishay Intertechnology, Inc., its affiliates, agents, and employees, and all persons acting on its or their behalf (collectively, "Vishay"), disclaim any and all liability for any errors, inaccuracies or incompleteness contained in any datasheet or in any other disclosure relating to any product.

Vishay makes no warranty, representation or guarantee regarding the suitability of the products for any particular purpose or the continuing production of any product. To the maximum extent permitted by applicable law, Vishay disclaims (i) any and all liability arising out of the application or use of any product, (ii) any and all liability, including without limitation special, consequential or incidental damages, and (iii) any and all implied warranties, including warranties of fitness for particular purpose, non-infringement and merchantability.

Statements regarding the suitability of products for certain types of applications are based on Vishay's knowledge of typical requirements that are often placed on Vishay products in generic applications. Such statements are not binding statements about the suitability of products for a particular application. It is the customer's responsibility to validate that a particular product with the properties described in the product specification is suitable for use in a particular application. Parameters provided in datasheets and/or specifications may vary in different applications and performance may vary over time. All operating parameters, including typical parameters, must be validated for each customer application by the customer's technical experts. Product specifications do not expand or otherwise modify Vishay's terms and conditions of purchase, including but not limited to the warranty expressed therein.

Except as expressly indicated in writing, Vishay products are not designed for use in medical, life-saving, or life-sustaining applications or for any other application in which the failure of the Vishay product could result in personal injury or death. Customers using or selling Vishay products not expressly indicated for use in such applications do so at their own risk and agree to fully indemnify and hold Vishay and its distributors harmless from and against any and all claims, liabilities, expenses and damages arising or resulting in connection with such use or sale, including attorneys fees, even if such claim alleges that Vishay or its distributor was negligent regarding the design or manufacture of the part. Please contact authorized Vishay personnel to obtain written terms and conditions regarding products designed for such applications.

No license, express or implied, by estoppel or otherwise, to any intellectual property rights is granted by this document or by any conduct of Vishay. Product names and markings noted herein may be trademarks of their respective owners.