

SKM 75GB063D



SEMITRANS[®] 2

Superfast NPT-IGBT Modules

SKM 75GB063D

SKM 75GAR063D

SKM 75GAL063D

Features

- N channel, homogeneous Si-structure (NPT-Non punch-through IGBT)
- Low tail current with low temperature dependence
- High short circuit capability, self limiting if term. G is clamped to E
- Pos. temp.-coeff. of V_{CEsat}
- Very low C_{ies} , C_{oes} , C_{res}
- Latch-up free
- Fast & soft inverse CAL diodes
- Isolated copper baseplate using DBC Direct Copper Bonding Technology without hard mould
- Large clearance (10 mm) and creepage distances (20 mm)

Typical Applications*

- Switching (not for linear use)
- Switched mode power supplies
- UPS
- Three phase inverters for servo / AC motor speed control
- Pulse frequencies also > 10kHz

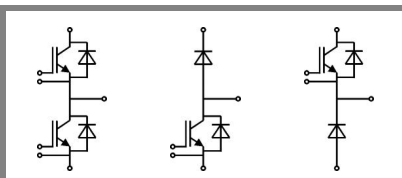

GB

GAL

GAR

Absolute Maximum Ratings		$T_c = 25^\circ\text{C}$, unless otherwise specified		
Symbol	Conditions	Values		Units
IGBT				
V_{CES}	$T_j = 25^\circ\text{C}$	600		V
I_C	$T_j = 150^\circ\text{C}$	$T_{case} = 25^\circ\text{C}$	100	A
		$T_{case} = 75^\circ\text{C}$	75	A
I_{CRM}	$I_{CRM} = 2 \times I_{Cnom}$	150		A
V_{GES}		± 20		V
t_{psc}	$V_{CC} = 300\text{V}; V_{GE} \leq 20\text{V}; T_j = 125^\circ\text{C}$ $V_{CES} < 600\text{V}$	10		μs
Inverse Diode				
I_F	$T_j = 150^\circ\text{C}$	$T_{case} = 25^\circ\text{C}$	75	A
		$T_{case} = 80^\circ\text{C}$	50	A
I_{FRM}	$I_{FRM} = 2 \times I_{Fnom}$	150		A
I_{FSM}	$t_p = 10\text{ms}; \sin.$	$T_j = 150^\circ\text{C}$	440	A
Freewheeling Diode				
I_F	$T_j = 150^\circ\text{C}$	$T_c = 25^\circ\text{C}$	100	A
		$T_c = 80^\circ\text{C}$	75	A
I_{FRM}	$I_{FRM} = 2 \times I_{Fnom}$	200		A
I_{FSM}	$t_p = 10\text{ms}; \sin$	$T_j = 150^\circ\text{C}$	720	A
Module				
$I_{t(RMS)}$		200		A
T_{vj}		- 40 ... + 150		$^\circ\text{C}$
T_{stg}		- 40 ... + 125		$^\circ\text{C}$
V_{isol}	AC, 1 min.	2500		V

Characteristics		$T_c = 25^\circ\text{C}$, unless otherwise specified			
Symbol	Conditions	min.	typ.	max.	Units
IGBT					
$V_{GE(th)}$	$V_{GE} = V_{CE}, I_C = 1\text{mA}$	4,5	5,5	6,5	V
I_{CES}	$V_{GE} = 0\text{V}, V_{CE} = V_{CES}$		0,1	0,3	mA
V_{CE0}		$T_j = 25^\circ\text{C}$	1,05		V
		$T_j = 125^\circ\text{C}$	1		V
r_{CE}	$V_{GE} = 15\text{V}$	$T_j = 25^\circ\text{C}$	14		m Ω
		$T_j = 125^\circ\text{C}$	18,7		m Ω
$V_{CE(sat)}$	$I_{Cnom} = 75\text{A}, V_{GE} = 15\text{V}$	$T_j = 25^\circ\text{C}_{chiplev.}$	2,1	2,5	V
		$T_j = 125^\circ\text{C}_{chiplev.}$	2,4	2,8	V
C_{ies}	$V_{CE} = 25, V_{GE} = 0\text{V}$	$f = 1\text{MHz}$	4,2		nF
C_{oes}			0,5		nF
C_{res}			0,3		nF
Q_G	$V_{GE} = 0\text{V} \dots +15\text{V}$	180		nC	
R_{Gint}	$T_j = ^\circ\text{C}$	0		Ω	
$t_{d(on)}$	$R_{Gon} = 15\ \Omega$	$V_{CC} = 300\text{V}$ $I_C = 75\text{A}$	60		ns
t_r			50		ns
E_{on}	$R_{Goff} = 15\ \Omega$	$T_j = 125^\circ\text{C}$ $V_{GE} = \pm 15\text{V}$	3		mJ
$t_{d(off)}$			350		ns
t_f			35		ns
E_{off}	per IGBT		2,5		mJ
$R_{th(j-c)}$			0,35		K/W



SEMITRANS[®] 2

Superfast NPT-IGBT Modules

SKM 75GB063D

SKM 75GAR063D

SKM 75GAL063D

Features

- N channel, homogeneous Si-structure (NPT-Non punch-through IGBT)
- Low tail current with low temperature dependence
- High short circuit capability, self limiting if term. G is clamped to E
- Pos. temp.-coeff. of V_{CEsat}
- Very low C_{ies} , C_{oes} , C_{res}
- Latch-up free
- Fast & soft inverse CAL diodes
- Isolated copper baseplate using DBC Direct Copper Bonding Technology without hard mould
- Large clearance (10 mm) and creepage distances (20 mm)

Typical Applications*

- Switching (not for linear use)
- Switched mode power supplies
- UPS
- Three phase inverters for servo / AC motor speed control
- Pulse frequencies also > 10kHz

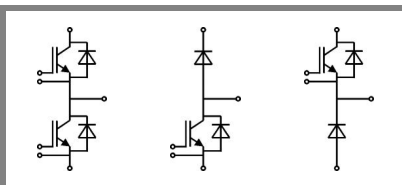

GB

GAL

GAR

Characteristics					
Symbol	Conditions	min.	typ.	max.	Units
Inverse Diode					
$V_F = V_{EC}$	$I_{Fnom} = 75 \text{ A}; V_{GE} = 0 \text{ V}$	$T_j = 25 \text{ }^\circ\text{C}_{chiplev.}$	1,55	1,9	V
		$T_j = 125 \text{ }^\circ\text{C}_{chiplev.}$	1,55		V
V_{F0}		$T_j = 125 \text{ }^\circ\text{C}$		0,9	V
r_F		$T_j = 125 \text{ }^\circ\text{C}$	10	13,3	m Ω
I_{RRM}	$I_F = 75 \text{ A}$	$T_j = 125 \text{ }^\circ\text{C}$	30		A
Q_{rr}	$di/dt = 800 \text{ A}/\mu\text{s}$		3,7		μC
E_{rr}	$V_{GE} = -15 \text{ V}; V_{CC} = 300 \text{ V}$				mJ
$R_{th(j-c)D}$	per diode			0,72	K/W
Freewheeling Diode					
$V_F = V_{EC}$	$I_{Fnom} = 100 \text{ A}; V_{GE} = 0 \text{ V}$	$T_j = 25 \text{ }^\circ\text{C}_{chiplev.}$	1,55	1,9	V
		$T_j = 125 \text{ }^\circ\text{C}_{chiplev.}$	1,55		V
V_{F0}		$T_j = 125 \text{ }^\circ\text{C}$		0,9	V
r_F		$T_j = 125 \text{ }^\circ\text{C}$	8	10	V
I_{RRM}	$I_F = 100 \text{ A}$	$T_j = 125 \text{ }^\circ\text{C}$	44		A
Q_{rr}	$di/dt = 0 \text{ A}/\mu\text{s}$		6		μC
E_{rr}	$V_{GE} = -15 \text{ V}; V_{CC} = 300 \text{ V}$				mJ
$R_{th(j-c)FD}$	per diode			0,6	K/W
Module					
L_{CE}				30	nH
R_{CC+EE}	res., terminal-chip	$T_{case} = 25 \text{ }^\circ\text{C}$	0,75		m Ω
		$T_{case} = 125 \text{ }^\circ\text{C}$	1		m Ω
$R_{th(c-s)}$	per module			0,05	K/W
M_s	to heat sink M6		3	5	Nm
M_t	to terminals M5		2,5	5	Nm
w				160	g

This is an electrostatic discharge sensitive device (ESDS), international standard IEC 60747-1, Chapter IX.

* The specifications of our components may not be considered as an assurance of component characteristics. Components have to be tested for the respective application. Adjustments may be necessary. The use of SEMIKRON products in life support appliances and systems is subject to prior specification and written approval by SEMIKRON. We therefore strongly recommend prior consultation of our personal.

SKM 75GB063D



SEMITRANS[®] 2

Superfast NPT-IGBT Modules

SKM 75GB063D

SKM 75GAR063D

SKM 75GAL063D

Features

- N channel, homogeneous Si-structure (NPT-Non punch-through IGBT)
- Low tail current with low temperature dependence
- High short circuit capability, self limiting if term. G is clamped to E
- Pos. temp.-coeff. of V_{CEsat}
- Very low C_{ies} , C_{oes} , C_{res}
- Latch-up free
- Fast & soft inverse CAL diodes
- Isolated copper baseplate using DBC Direct Copper Bonding Technology without hard mould
- Large clearance (10 mm) and creepage distances (20 mm)

Typical Applications*

- Switching (not for linear use)
- Switched mode power supplies
- UPS
- Three phase inverters for servo / AC motor speed control
- Pulse frequencies also > 10kHz

Z_{th}		Values	Units
Symbol	Conditions		
$Z_{th(j-c)}$			
R_{θ}	$i = 1$	250	mk/W
R_{θ}	$i = 2$	70	mk/W
R_{θ}	$i = 3$	25	mk/W
R_{θ}	$i = 4$	5	mk/W
τ_{θ}	$i = 1$	0,0874	s
τ_{θ}	$i = 2$	0,0078	s
τ_{θ}	$i = 3$	0,0017	s
τ_{θ}	$i = 4$	0,0001	s
$Z_{th(j-c)D}$			
R_{θ}	$i = 1$	550	mk/W
R_{θ}	$i = 2$	340	mk/W
R_{θ}	$i = 3$	92	mk/W
R_{θ}	$i = 4$	18	mk/W
τ_{θ}	$i = 1$	0,0761	s
τ_{θ}	$i = 2$	0,0045	s
τ_{θ}	$i = 3$	0,011	s
τ_{θ}	$i = 4$	0,0002	s

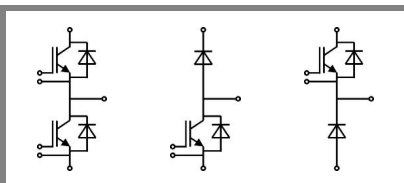

GB

GAL

GAR

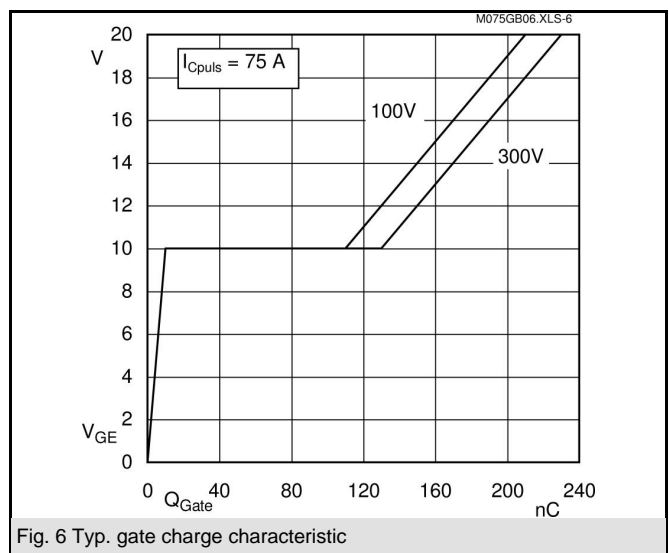
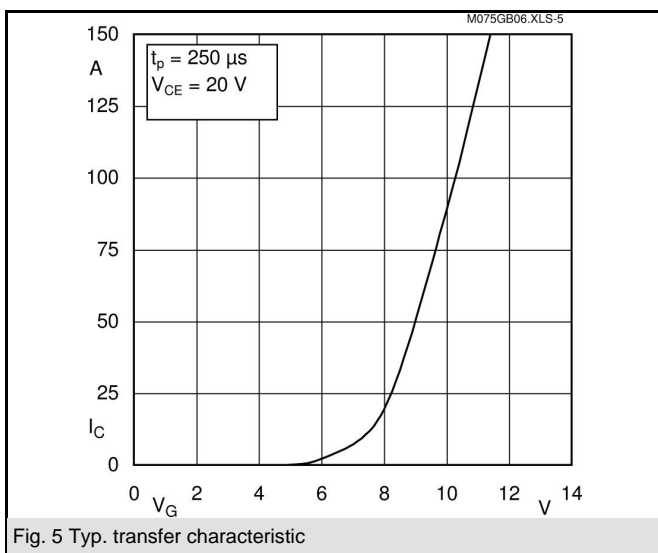
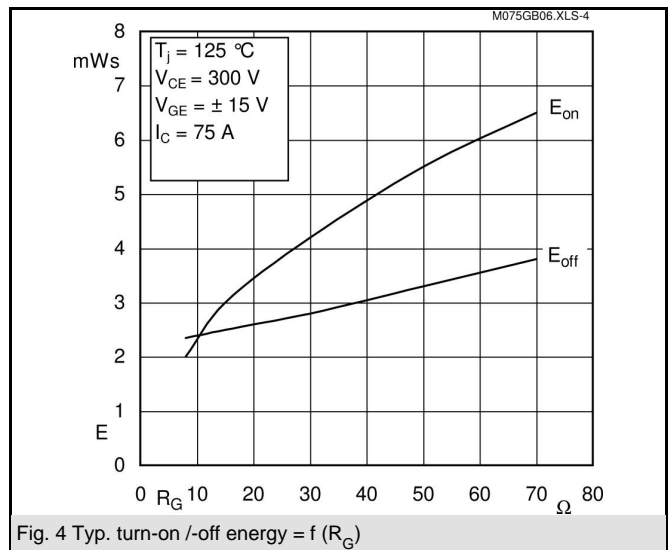
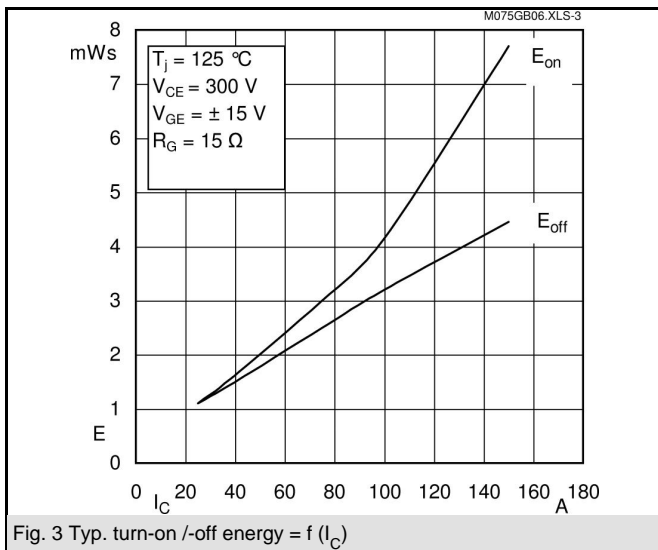
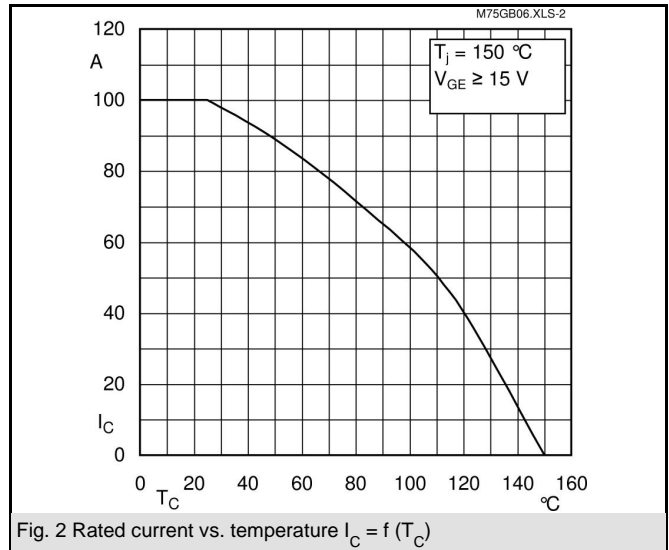
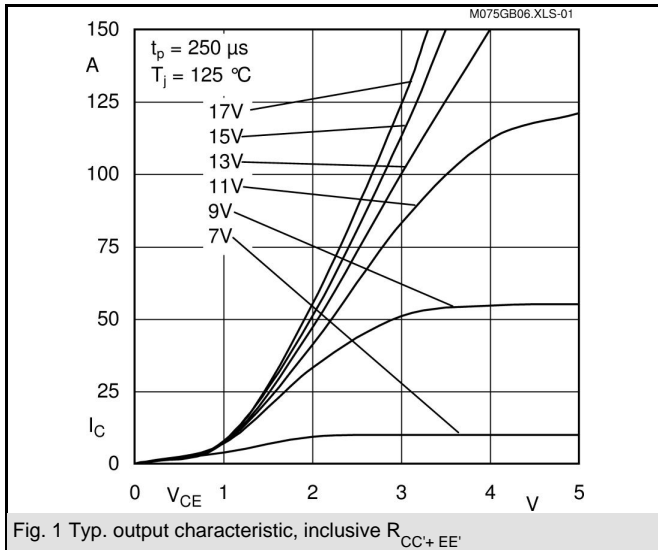

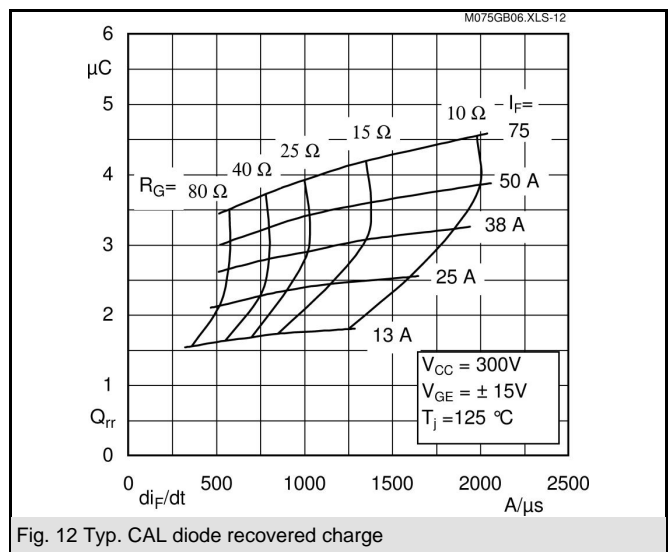
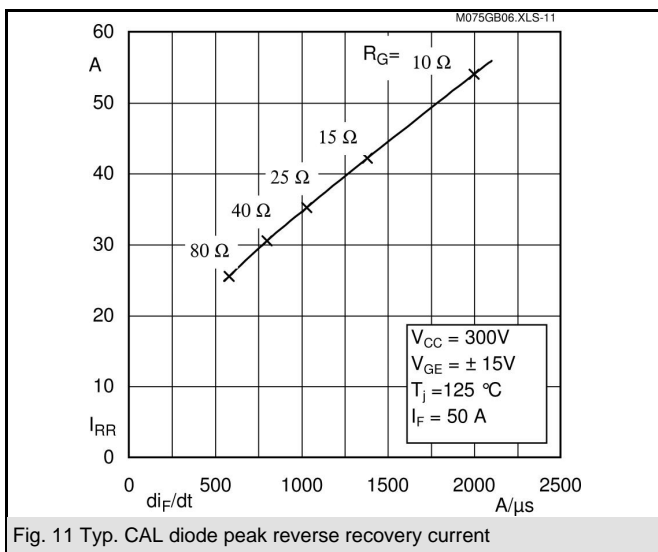
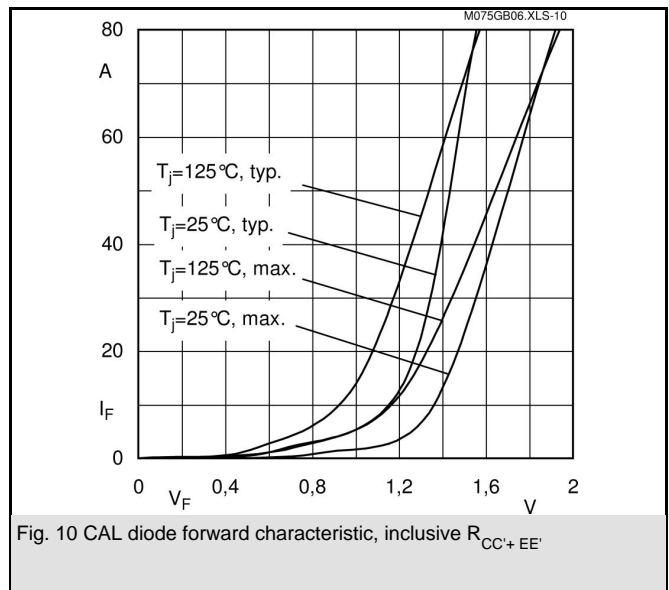
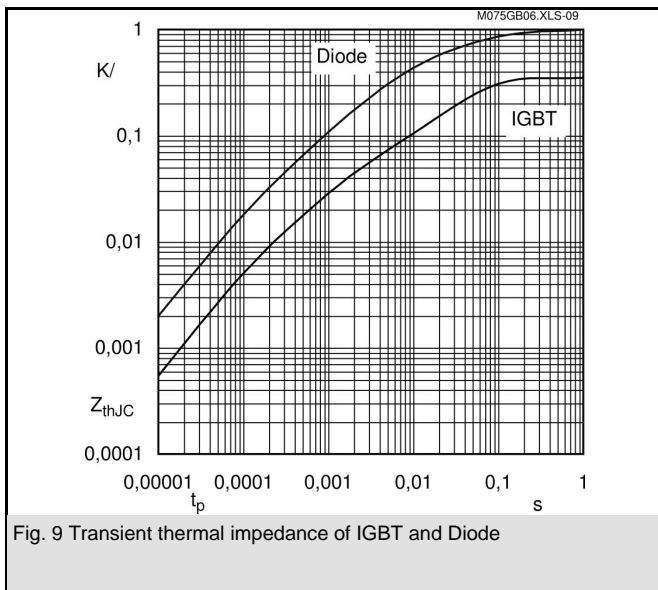
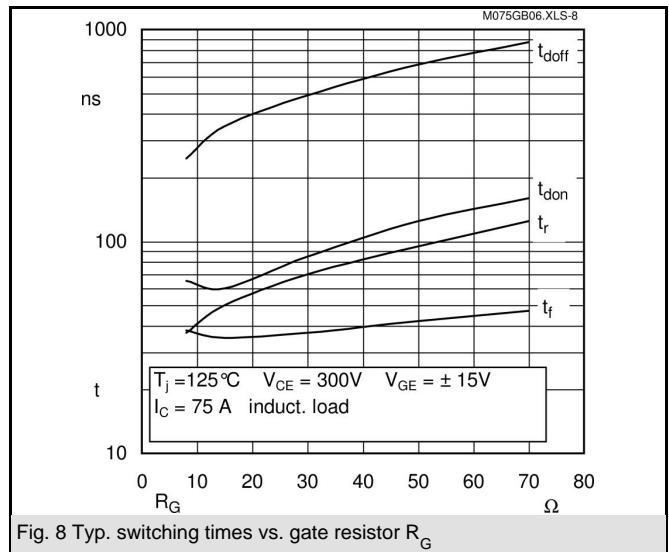
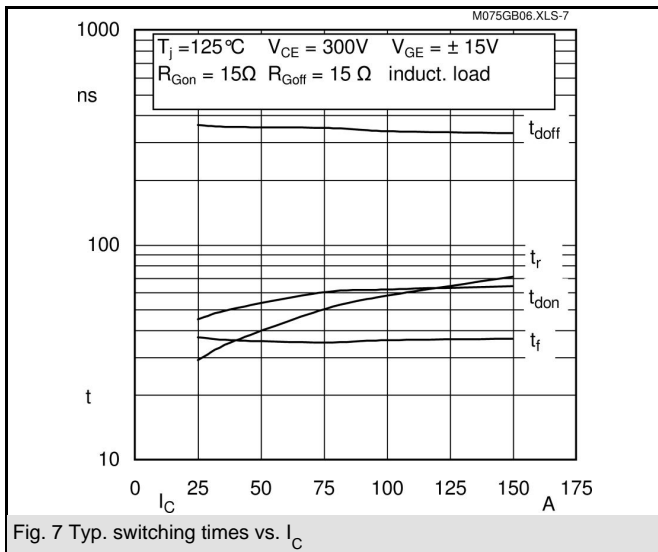

SKM 75GB063D

UL recognized

CASED61

File no. E 63 532

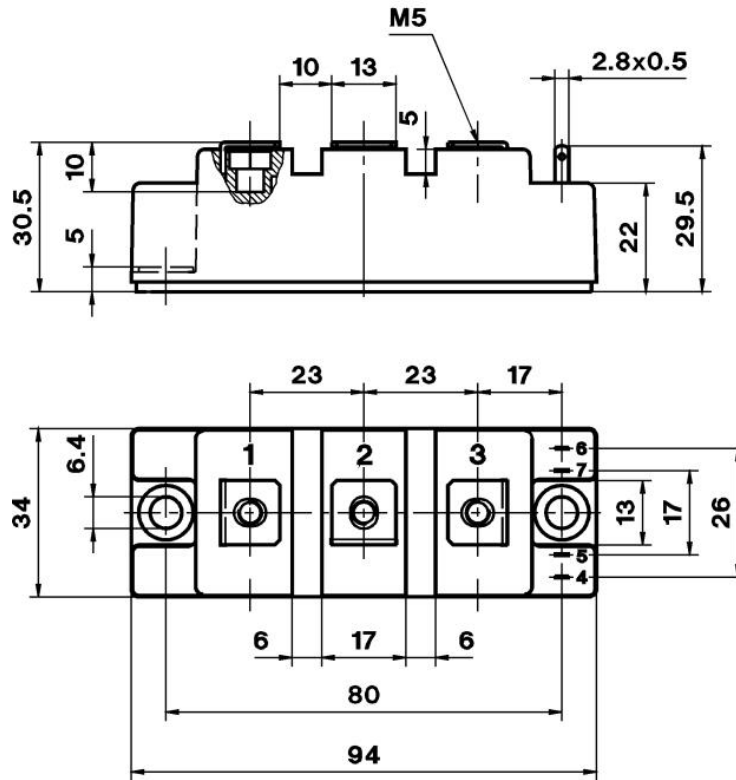

Case D 61

