

Power Integrated Module (PIM)

■ Features

- NPT-Technology
- Solderable Package
- Square SC SOA at $10 \times I_C$
- High Short Circuit Withstand-Capability
- Small Temperature Dependence of the Turn-Off Switching Loss
- Low Losses And Soft Switching

■ Equivalent Circuit

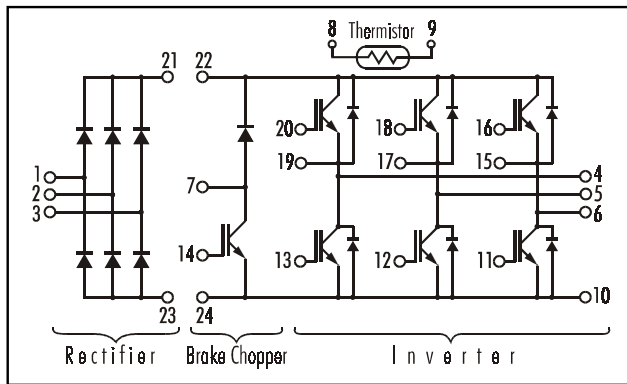

■ Outline Drawing

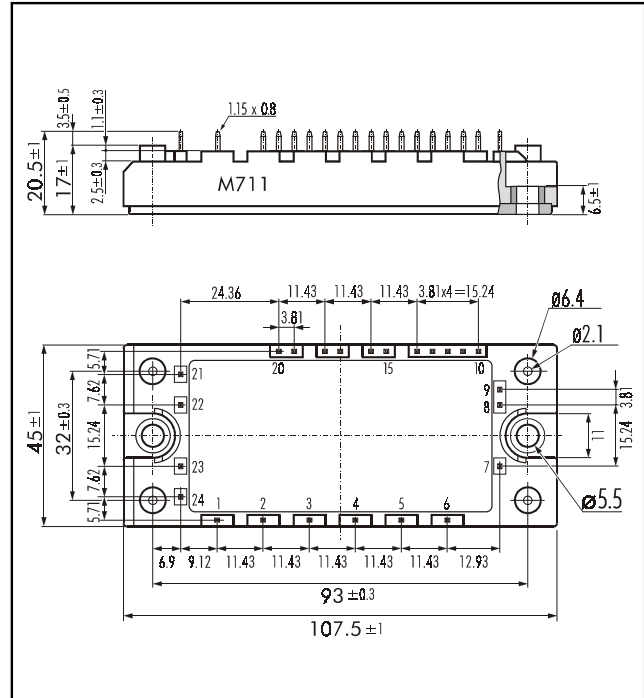

■ Absolute Maximum Ratings ($T_c=25^\circ\text{C}$)

	Items	Symbols	Test Conditions	Ratings	Units		
Inverter	Collector-Emitter Voltage	V_{CES}		1200	V		
	Gate -Emitter Voltage	V_{GES}		± 20			
	Collector Current	I_C	Continuous	$25^\circ\text{C} / 80^\circ\text{C}$	35 / 25	A	
			$I_{C\text{ PULSE}}$	1ms	$25^\circ\text{C} / 80^\circ\text{C}$		70 / 50
			$-I_{C\text{ PULSE}}$				25
Collector Power Dissipation	P_C	1 device		180	W		
Rectifier	Repetitive Peak Reverse Voltage	V_{RRM}		1600	V		
	Average Output Current	I_O	50Hz/60Hz sinus wave	25	A		
	Surge Current (Non Repetitive)	I_{FSM}	$T_J=150^\circ\text{C}$, 10 ms, sinus wave	260			
	I^2t (Non Repetitive)			338	A^2s		
Brake Chopper	Collector-Emitter Voltage	V_{CES}		1200	V		
	Gate -Emitter Voltage	V_{GES}		± 20			
	Collector Current	I_C	Continuous	$25^\circ\text{C} / 80^\circ\text{C}$	25 / 15	A	
			$I_{C\text{ PULSE}}$	1ms	$25^\circ\text{C} / 80^\circ\text{C}$		50 / 30
	Collector Power Dissipation	P_C	1 device		110	W	
	Repetitive Peak Reverse Voltage	V_{RRM}			1200	V	
Operating Junction Temperature	T_J			+150	$^\circ\text{C}$		
Storage Temperature	T_{Stg}			-40 ~ +125			
Isolation Voltage	V_{ISO}	A.C. 1min.		2500	V		
Mounting Screw Torque*				3.5	Nm		

Note: *:Recommendable Value; 2.5 ~ 3.5 Nm (M5)

■ Electrical Characteristics (T_J=25°C)

Items		Symbols	Test Conditions	Min.	Typ.	Max.	Units	
Inverter	IGBT	Zero Gate Voltage Collector Current	I _{CES}	V _{GE} =0V V _{CE} =1200V			1.0	mA
		Gate-Emitter Leakage Current	I _{GES}	V _{CE} =0V V _{GE} =± 20V			200	nA
		Gate-Emitter Threshold Voltage	V _{GE(th)}	V _{GE} =20V I _C =25mA	5.5	7.2	8.5	
		Collector-Emitter Saturation Voltage	V _{CE(sat)}	V _{GE} =15V I _C = 25A	Chip	2.1		V
		Input Capacitance	C _{ies}	f=1MHz, V _{GE} =0V, V _{CE} =10V		3000		pF
	Turn-on Time	t _{on}	V _{CC} = 600V I _C = 25A		0.35	1.2		
		t _{r,x}	V _{GE} = ±15V		0.25	0.6		
		t _{r,i}	R _G = 51Ω		0.45	1.0		
		t _{off}	Inductive Load		0.08	0.3		
		t _f						
FRD	Diode Forward On-Voltage	V _F	I _F =25A	Chip	2.3		V	
	Reverse Recovery Time	t _{rr}	I _F =25A	Terminal	2.4	3.2	ns	
Rectifier	Forward Voltage	V _{FM}	I _F =25A	Chip	1.1		V	
	Reverse Current	I _{RRM}	V _R =1600V	Terminal	1.2	1.5	mA	
Brake Chopper	Zero Gate Voltage Collector Current	I _{CES}	V _{GE} =0V V _{CE} =1200V			1.0	mA	
	Gate-Emitter Leakage Current	I _{GES}	V _{CE} =0V V _{GE} =± 20V			200	nA	
	Collector-Emitter Saturation Voltage	V _{CE(sat)}	V _{GE} =15V I _C =15A	Chip	2.10		V	
				Terminal	2.20	2.6		
	Turn-on Time	t _{on}	V _{CC} = 600V I _C = 15A		0.35	1.2		
		t _{r,x}	V _{GE} = ±15V		0.25	0.6		
		t _{r,i}	R _G = 82Ω		0.45	1.0	μs	
Turn-off Time	t _{off}	Inductive Load		0.08	0.3			
	t _f							
Reverse Current	I _{RRM}	V _R =1200V			1.0	mA		
NTC	Resistance	R	T= 25°C		5000		Ω	
			T=100°C	465	495	520		
	B Value	B	T=25 / 50°C	3305	3375	3450		K

■ Thermal Characteristics

Items	Symbols	Test Conditions	Min.	Typ.	Max.	Units
Thermal Resistance (1 device)	R _{th(j-c)}	Inverter IGBT			0.69	°C/W
		Inverter FRD			1.30	
		Brake IGBT			1.14	
		Rectifier Diode			0.90	
Contact Thermal Resistance	R _{th(c-f)}	With Thermal Compound		0.05		

