

SKM 75GB123D



SEMITRANS[®] 2

IGBT Modules

SKM 75GB123D

SKM 75GAL123D

SKM 75GAR123D

Features

- MOS input (voltage controlled)
- Low inductance case
- Very low tail current with low temperature dependence
- High short circuit capability, self limiting to $6 \times I_{Cnom}$
- Latch-up free
- Fast & soft inverse CAL diodes
- Isolated copper baseplate using DCB Direct Copper Bonding Technology
- Large clearance (10 mm) and creepage distance (20 mm)

Typical Applications*

- AC inverter drives
- UPS

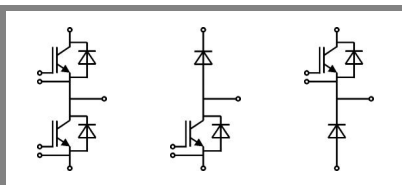

GB

GAL

GAR

| Absolute Maximum Ratings | | $T_c = 25\text{ }^\circ\text{C}$, unless otherwise specified | | |
|--------------------------|--|---|---------------|---|
| Symbol | Conditions | Values | Units | |
| IGBT | | | | |
| V_{CES} | $T_j = 25\text{ }^\circ\text{C}$ | 1200 | V | |
| I_C | $T_j = 150\text{ }^\circ\text{C}$ | $T_{case} = 25\text{ }^\circ\text{C}$ | 75 | A |
| | | $T_{case} = 80\text{ }^\circ\text{C}$ | 60 | A |
| I_{CRM} | $I_{CRM} = 2 \times I_{Cnom}$ | 150 | A | |
| V_{GES} | | ± 20 | V | |
| t_{psc} | $V_{CC} = 600\text{ V}; V_{GE} \leq 20\text{ V}; T_j = 125\text{ }^\circ\text{C}$ $V_{CES} < 1200\text{ V}$ | 10 | μs | |

| Inverse Diode | | | | |
|----------------------|-----------------------------------|---------------------------------------|-----|---|
| I_F | $T_j = 150\text{ }^\circ\text{C}$ | $T_{case} = 25\text{ }^\circ\text{C}$ | 75 | A |
| | | $T_{case} = 80\text{ }^\circ\text{C}$ | 50 | A |
| I_{FRM} | $I_{FRM} = 2 \times I_{Fnom}$ | 150 | A | |
| I_{FSM} | $t_p = 10\text{ ms}; \sin.$ | $T_j = 150\text{ }^\circ\text{C}$ | 480 | A |

| Freewheeling Diode | | | | |
|---------------------------|-----------------------------------|---------------------------------------|-----|---|
| I_F | $T_j = 150\text{ }^\circ\text{C}$ | $T_{case} = 25\text{ }^\circ\text{C}$ | 95 | A |
| | | $T_{case} = 80\text{ }^\circ\text{C}$ | 65 | A |
| I_{FRM} | $I_{FRM} = 2 \times I_{Fnom}$ | 200 | A | |
| I_{FSM} | $t_p = 10\text{ ms}; \sin$ | $T_j = 150\text{ }^\circ\text{C}$ | 720 | A |

| Module | | | |
|---------------|------------|----------------|------------------|
| $I_{t(RMS)}$ | | 200 | A |
| T_{vj} | | - 40 ... + 150 | $^\circ\text{C}$ |
| T_{stg} | | - 40 ... + 125 | $^\circ\text{C}$ |
| V_{isol} | AC, 1 min. | 2500 | V |

| Characteristics | | $T_c = 25\text{ }^\circ\text{C}$, unless otherwise specified | | | | |
|-----------------|--|---|------|------|------------|----|
| Symbol | Conditions | min. | typ. | max. | Units | |
| IGBT | | | | | | |
| $V_{GE(th)}$ | $V_{GE} = V_{CE}, I_C = 2\text{ mA}$ | 4,5 | 5,5 | 6,5 | V | |
| I_{CES} | $V_{GE} = 0\text{ V}, V_{CE} = V_{CES}$ | | 0,1 | 0,3 | mA | |
| V_{CE0} | | $T_j = 25\text{ }^\circ\text{C}$ | 1,4 | 1,6 | V | |
| | | $T_j = 125\text{ }^\circ\text{C}$ | 1,6 | 1,8 | V | |
| r_{CE} | $V_{GE} = 15\text{ V}$ | $T_j = 25\text{ }^\circ\text{C}$ | 22 | 28 | m Ω | |
| | | $T_j = 125\text{ }^\circ\text{C}$ | 30 | 38 | m Ω | |
| $V_{CE(sat)}$ | $I_{Cnom} = 50\text{ A}, V_{GE} = 15\text{ V}$ | | 2,5 | 3 | V | |
| C_{ies} | $V_{CE} = 25, V_{GE} = 0\text{ V}$ | $f = 1\text{ MHz}$ | | 3,3 | 4,3 | nF |
| C_{oes} | | | | 0,5 | 0,6 | nF |
| C_{res} | | | | 0,22 | 0,3 | nF |
| Q_G | $V_{GE} = -8 - +20\text{ V}$ | | 500 | | nC | |
| R_{Gint} | $T_j = \text{ }^\circ\text{C}$ | | 5 | | Ω | |
| $t_{d(on)}$ | $R_{Gon} = 22\text{ }^\circ\Omega$ | $V_{CC} = 600\text{ V}$ $I_C = 50\text{ A}$ | 44 | 100 | ns | |
| t_r | | | 56 | 100 | ns | |
| E_{on} | $R_{Goff} = 22\text{ }^\circ\Omega$ | $T_j = 125\text{ }^\circ\text{C}$ $V_{GE} = \pm 15\text{ V}$ | 8 | | mJ | |
| $t_{d(off)}$ | | | 380 | 500 | ns | |
| t_f | | | 70 | 100 | ns | |
| E_{off} | | | 5 | | mJ | |
| $R_{th(j-c)}$ | per IGBT | | | 0,27 | K/W | |

SKM 75GB123D

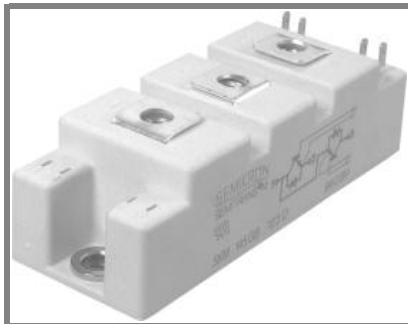

SEMITRANS[®] 2

IGBT Modules

SKM 75GB123D

SKM 75GAL123D

SKM 75GAR123D

Features

- MOS input (voltage controlled)
- Low inductance case
- Very low tail current with low temperature dependence
- High short circuit capability, self limiting to $6 \times I_{cnom}$
- Latch-up free
- Fast & soft inverse CAL diodes
- Isolated copper baseplate using DCB Direct Copper Bonding Technology
- Large clearance (10 mm) and creepage distance (20 mm)

Typical Applications*

- AC inverter drives
- UPS

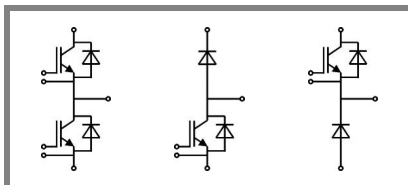

GB

GAL

GAR

| Characteristics | | | | | |
|---------------------------|---|---|------|------|-------|
| Symbol | Conditions | min. | typ. | max. | Units |
| Inverse Diode | | | | | |
| $V_F = V_{EC}$ | $I_{Fnom} = 50 \text{ A}; V_{GE} = 0 \text{ V}$ | $T_j = 25 \text{ }^\circ\text{C}_{chiplev.}$ | 2 | 2,5 | V |
| | | $T_j = 125 \text{ }^\circ\text{C}_{chiplev.}$ | 1,8 | | V |
| V_{F0} | | $T_j = 25 \text{ }^\circ\text{C}$ | 1,1 | 1,2 | V |
| | | $T_j = 125 \text{ }^\circ\text{C}$ | | | V |
| r_F | | $T_j = 25 \text{ }^\circ\text{C}$ | 18 | 26 | mΩ |
| | | $T_j = 125 \text{ }^\circ\text{C}$ | | | mΩ |
| I_{RRM} | $I_F = 50 \text{ A}$ | $T_j = 125 \text{ }^\circ\text{C}$ | 35 | | A |
| Q_{rr} | $di/dt = 800 \text{ A}/\mu\text{s}$ | | | | μC |
| E_{tr} | $V_{GE} = 0 \text{ V}; V_{CC} = 600 \text{ V}$ | | | | mJ |
| $R_{th(j-c)D}$ | per diode | | | 0,6 | K/W |
| Freewheeling Diode | | | | | |
| $V_F = V_{EC}$ | $I_{Fnom} = 50 \text{ A}; V_{GE} = 0 \text{ V}$ | $T_j = 25 \text{ }^\circ\text{C}_{chiplev.}$ | 1,85 | 2,2 | V |
| | | $T_j = 125 \text{ }^\circ\text{C}_{chiplev.}$ | 1,6 | | V |
| V_{F0} | | $T_j = 25 \text{ }^\circ\text{C}$ | 1,1 | 1,2 | V |
| | | $T_j = 125 \text{ }^\circ\text{C}$ | | | V |
| r_F | | $T_j = 25 \text{ }^\circ\text{C}$ | 15 | 20 | V |
| | | $T_j = 125 \text{ }^\circ\text{C}$ | | | V |
| I_{RRM} | $I_F = 50 \text{ A}$ | $T_j = 125 \text{ }^\circ\text{C}$ | 40 | | A |
| Q_{rr} | | | | | μC |
| E_{tr} | $V_{GE} = 0 \text{ V}; V_{CC} = 600 \text{ V}$ | | | | mJ |
| $R_{th(j-c)FD}$ | per diode | | | 0,5 | K/W |
| Module | | | | | |
| L_{CE} | | | | 30 | nH |
| $R_{CC'+EE'}$ | res., terminal-chip | $T_{case} = 25 \text{ }^\circ\text{C}$ | 0,75 | | mΩ |
| | | $T_{case} = 125 \text{ }^\circ\text{C}$ | 1 | | mΩ |
| $R_{th(c-s)}$ | per module | | | 0,05 | K/W |
| M_s | to heat sink M6 | | 3 | 5 | Nm |
| M_t | to terminals M5 | | 2,5 | 5 | Nm |
| w | | | | 160 | g |

This is an electrostatic discharge sensitive device (ESDS), international standard IEC 60747-1, Chapter IX.

* The specifications of our components may not be considered as an assurance of component characteristics. Components have to be tested for the respective application. Adjustments may be necessary. The use of SEMIKRON products in life support appliances and systems is subject to prior specification and written approval by SEMIKRON. We therefore strongly recommend prior consultation of our personal.

SKM 75GB123D

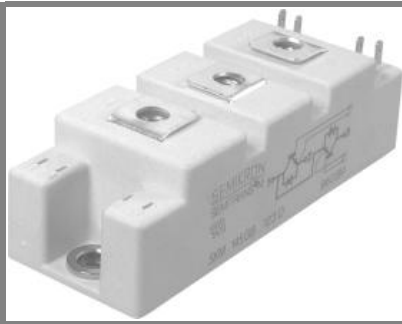

SEMITRANS[®] 2

IGBT Modules

SKM 75GB123D

SKM 75GAL123D

SKM 75GAR123D

Features

- MOS input (voltage controlled)
- Low inductance case
- Very low tail current with low temperature dependence
- High short circuit capability, self limiting to $6 \times I_{cnom}$
- Latch-up free
- Fast & soft inverse CAL diodes
- Isolated copper baseplate using DCB Direct Copper Bonding Technology
- Large clearance (10 mm) and creepage distance (20 mm)

Typical Applications*

- AC inverter drives
- UPS

| Z_{th} | | Values | Units |
|-----------------|------------|--------|-------|
| Symbol | Conditions | | |
| $Z_{th(j-c)I}$ | | | |
| R_{θ} | $i = 1$ | 180 | mk/W |
| R_{θ} | $i = 2$ | 64 | mk/W |
| R_{θ} | $i = 3$ | 22 | mk/W |
| R_{θ} | $i = 4$ | 4 | mk/W |
| τ_{θ} | $i = 1$ | 0,0327 | s |
| τ_{θ} | $i = 2$ | 0,0479 | s |
| τ_{θ} | $i = 3$ | 0,008 | s |
| τ_{θ} | $i = 4$ | 0,005 | s |
| $Z_{th(j-c)D}$ | | | |
| R_{θ} | $i = 1$ | 380 | mk/W |
| R_{θ} | $i = 2$ | 190 | mk/W |
| R_{θ} | $i = 3$ | 26 | mk/W |
| R_{θ} | $i = 4$ | 4 | mk/W |
| τ_{θ} | $i = 1$ | 0,0947 | s |
| τ_{θ} | $i = 2$ | 0,006 | s |
| τ_{θ} | $i = 3$ | 0,08 | s |
| τ_{θ} | $i = 4$ | 0,003 | s |

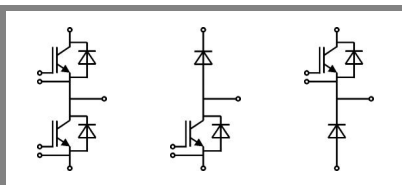

GB

GAL

GAR

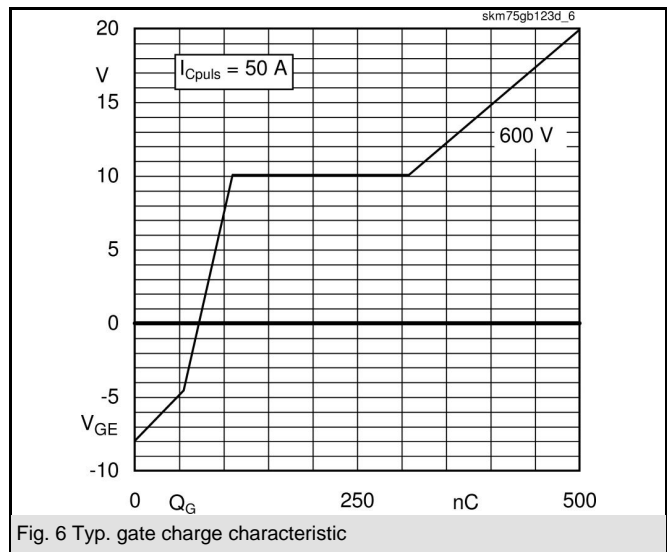
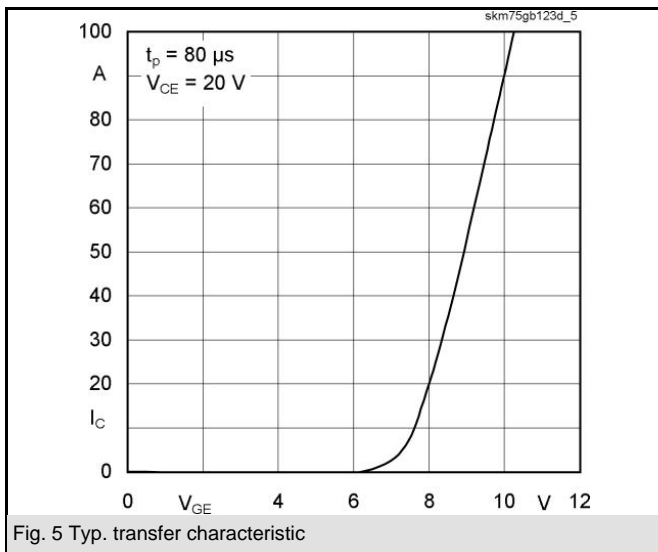
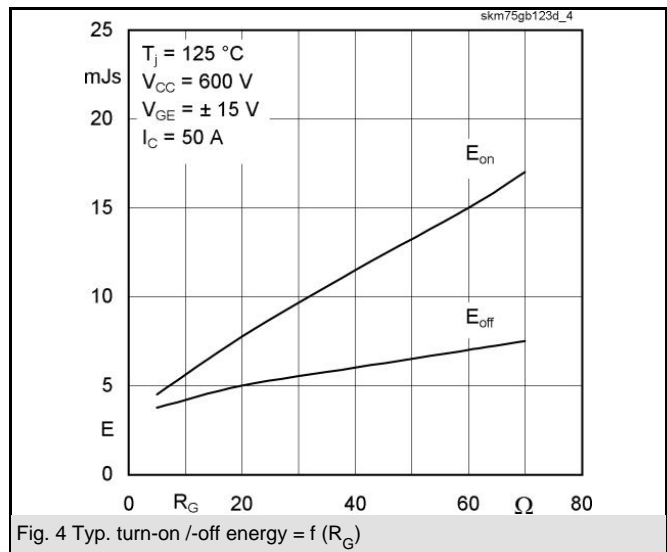
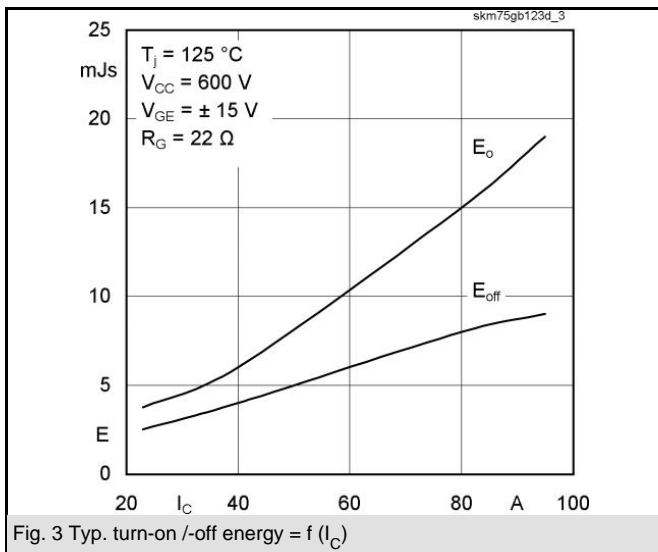
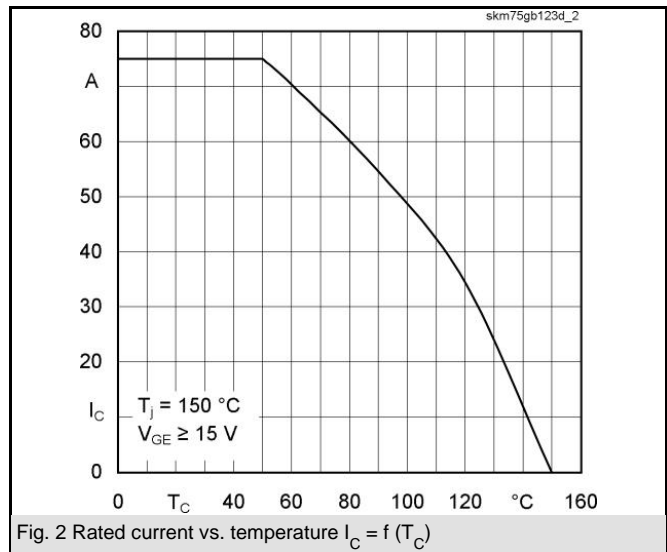
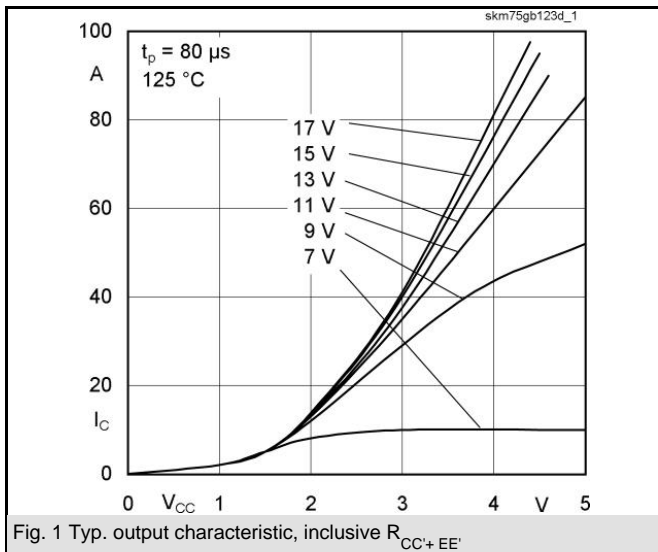

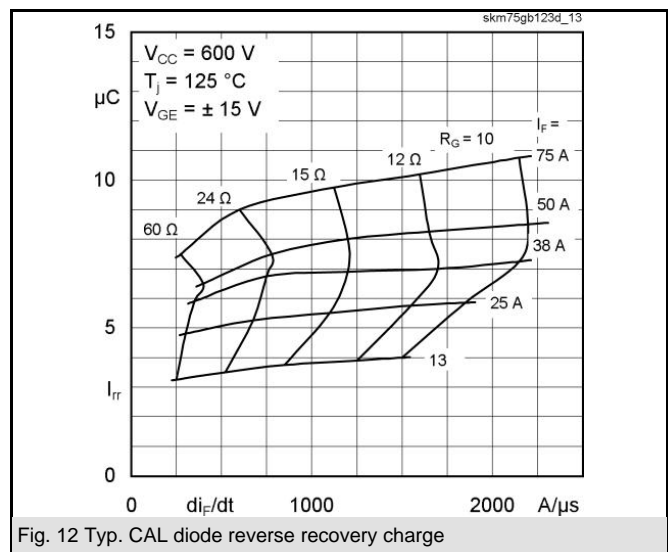
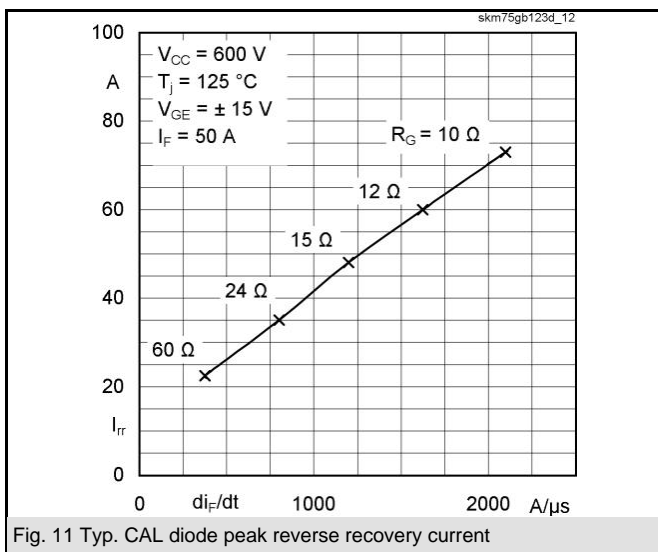
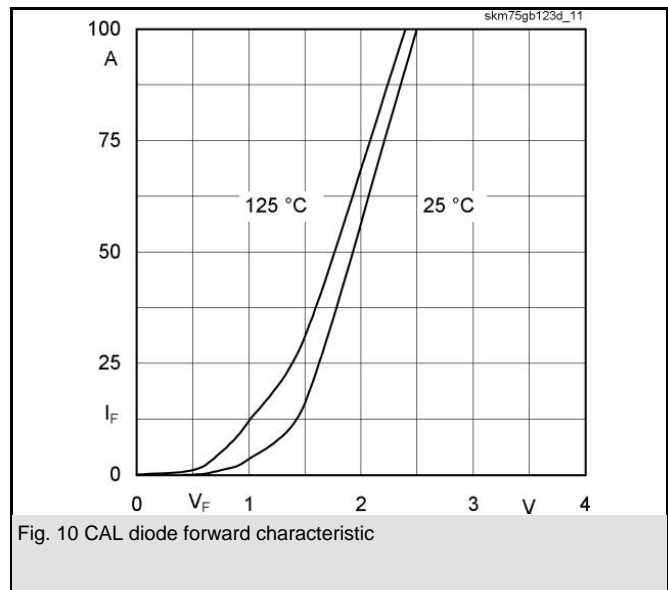
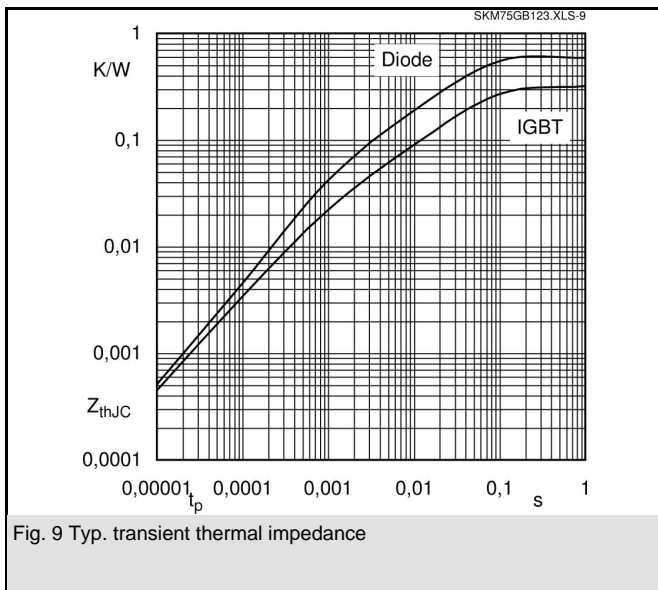
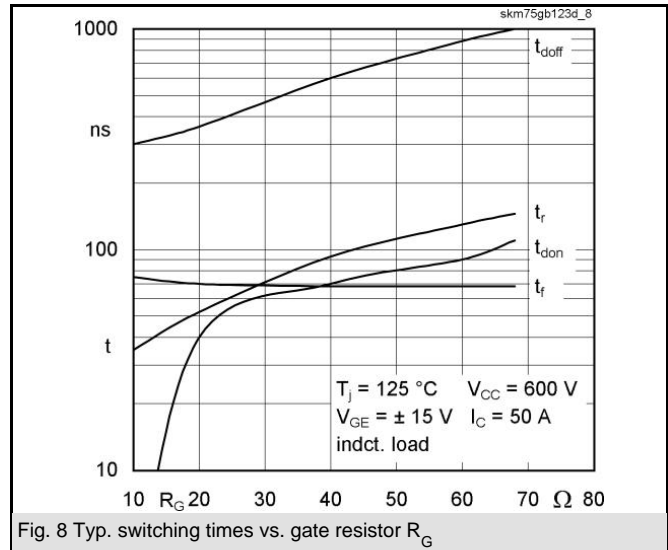
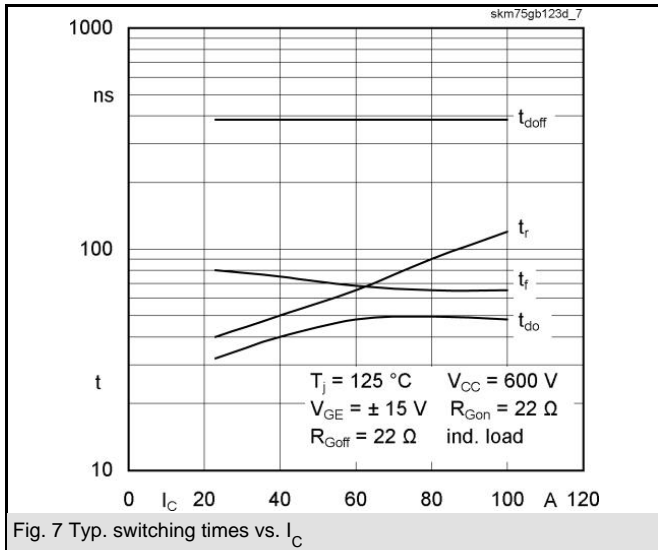

SKM 75GB123D

UL Recognized

CASED61

File 63 532

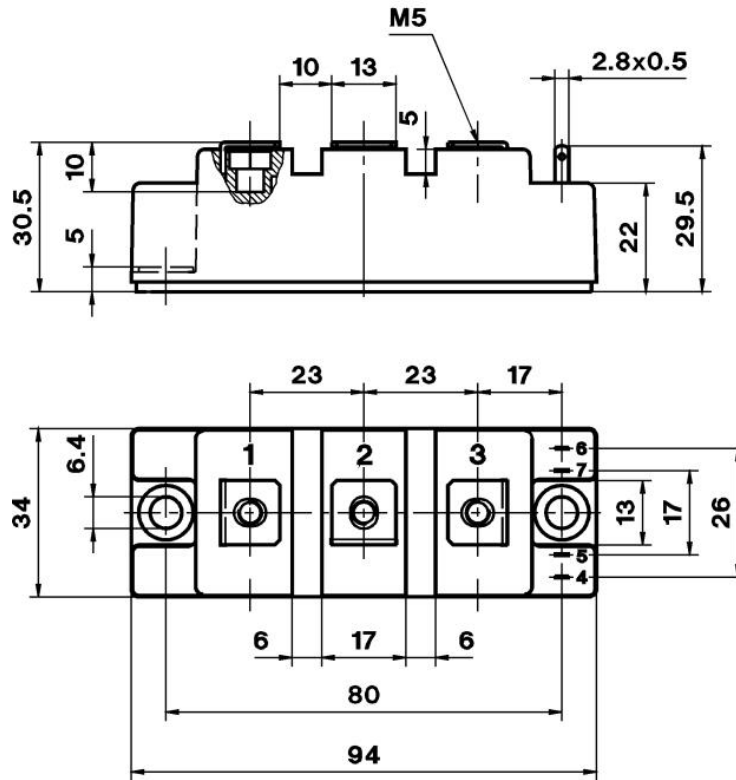

Case D 61

