

OBSOLETE PRODUCT

Contact Factory for Replacement Model

WPC10R

2:1 WIDE INPUT RANGE DC/DC CONVERTER



DESCRIPTION

The WPC10R is a family of high performance DC/DC converters that offer regulated outputs over two input voltage ranges of 18 - 36 and 28 - 75V and over a wide specification temperature range of -40°C to +100°C.

The 350kHz switching frequency and forward converter topology provide optimum performance in a space-saving package. The design uses all surface mounted components, including magnetics, to provide enhanced reliability. All models will operate even under no-load conditions, although a minimum load is specified for load regulation measurement purposes. A metal package is utilized for decreased radiated noise and an optional remote enable feature allows low power standby operation.

FEATURES

- SAFETY APPROVALS (cULus, CE)
- MEETS EN55022 LEVEL A & B FOR CONDUCTED EMISSIONS WITH A 10 MICROFARAD EXTERNAL CAPACITOR
- SPECIFICATION TEMPERATURE RANGE: -40°C TO +100°C
- INDUSTRY STANDARD PINOUTS
- INDUSTRY STANDARD PACKAGE
- LOW PROFILE 0.4 INCH (10MM)
- SHORT CIRCUIT PROTECTION
- TEMPERATURE SHUTDOWN
- REMOTE ON/OFF (OPTIONAL)
- LOW RADIATED EMISSIONS

APPLICATIONS

- TELECOMMUNICATION APPLICATIONS
- BATTERY POWERED SYSTEMS
- PORTABLE INSTRUMENTS
- PROCESS CONTROL EQUIPMENT
- TRANSPORTATION EQUIPMENT
- DISTRIBUTED POWER SYSTEMS

SIMPLIFIED CIRCUIT DIAGRAM

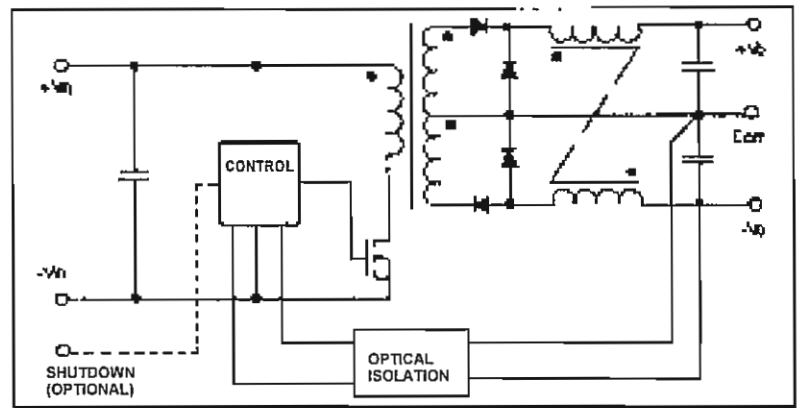

AGENCY APPROVALS



ELECTRICAL SPECIFICATIONS

Specifications typical at $T_A = +25^{\circ}\text{C}$, nominal input voltage, rated output current unless otherwise specified.

MODEL	NOMINAL INPUT VOLTAGE (VDC)	RATED OUTPUT VOLTAGE (VDC)	OUTPUT CURRENT		VOLTAGE REGULATION		NOISE (mVpp)	EFFICIENCY (%)
			MIN LOAD (mA)	RATED LOAD (mA)	LINE (\pm)	LOAD (\pm)		
WPC10R24S03	24	3.3	300	3000	0.5%	1%	75	75
WPC10R24S05	24	5	200	2000	0.5%	1%	75	77
WPC10R24S12	24	12	83	833	0.5%	1%	75	78
WPC10R24S15	24	15	67	666	0.5%	1%	75	79
WPC10R24D05	24	± 5	± 100	± 1000	0.5%	2%	75	74
WPC10R24D12	24	± 12	± 42	± 417	0.5%	2%	75	78
WPC10R24D15	24	± 15	± 33	± 333	0.5%	2%	75	79
WPC10R48S03	48	3.3	300	3000	0.5%	1%	75	77
WPC10R48S05	48	5	200	2000	0.5%	1%	75	79
WPC10R48S12	48	12	83	833	0.5%	1%	75	80
WPC10R48S15	48	15	67	666	0.5%	1%	75	81
WPC10R48D05	48	± 5	± 100	± 1000	0.5%	2%	75	79
WPC10R48D12	48	± 12	± 42	± 417	0.5%	2%	75	80
WPC10R48D15	48	± 15	± 33	± 333	0.5%	2%	75	81

COMMON SPECIFICATIONS

Specifications typical at $T_A = +25^{\circ}\text{C}$, nominal input voltage, rated output current unless otherwise specified.

PARAMETER	CONDITIONS	MIN	TYP	MAX	UNITS
INPUT					
Voltage Range		18	24	36	Vdc
Reflected Ripple Current	$V_{IN}=34-75$ for 3.3Vout	28	48	75	Vdc
			20	50	mAp-p
ISOLATION					
Test Voltage	60 Hz, 10 Seconds	1500			Vpk
Resistance			10		G Ω
Capacitance			1500		pF
Leakage Current	$V_{ISO} = 240\text{VAC}$, 60Hz		100		mArms
OUTPUT					
Rated Power				10	Watts
Voltage Setpoint Accuracy			± 1		%
Temperature Coefficient			± 0.02		%/ $^{\circ}\text{C}$
Line Regulation	Low Line to High Line				%
Singles			± 0.2		%
Duals			± 0.2		%
Load Regulation	Min Load to Rated Load				%
Singles			± 0.2		%
Duals			± 0.5		%
Ripple & Noise	BW = 5 Hz to 20 MHz			75	mVp-p
GENERAL					
Switching Frequency			350		kHz
MTTF per MIL-HDBK-217, Rev F	Circuit Stress Method,		933		khr
Ground Benign	$T_A = +25^{\circ}\text{C}$				
Package Weight			35		g
TEMPERATURE					
Specification (ambient)		-40		+71	$^{\circ}\text{C}$
Specification (case)		-40		+100	$^{\circ}\text{C}$
Storage		-55		+125	$^{\circ}\text{C}$

ABSOLUTE MAXIMUM RATINGS

Output Short Circuit Protection
 (at $T_A = 25^\circ\text{C}$, nominal input voltage)Continuous
 Internal Power Dissipation..... 2.5W
 Lead Temperature (soldering 10seconds, max)+300°C
 Maximum Case Temperature+110°C

ORDERING INFORMATION

WPC10R xxyz N/P/F R

Device Family _____
 Indicates Wide Input Voltage 10 Watt Regulated Unit
 Model Number _____
 Selected from Table of Electrical Characteristics
 xx = Input Voltage
 y = Number of Outputs (Single "S", Dual "D")
 zz = Output Voltage
 Case Ground Option _____
 "P" = Positive Input Connection
 "N" = Negative Input Connection
 "F" = Floating Input Connection
 Remote ON/OFF (optional) _____

MECHANICAL

TOP VIEW

SIDE VIEW

Pin Connections

1	+Vin
2	-Vin
3	Remote On/Off
4	+Vout
5	Common
6	-Vout

BOTTOM VIEW

NOTES: All dimensions are in inches (millimeters).
 GRID: 0.100 inches (2.54 millimeters)
 Pin Placement Tolerance: ±0.015
 * Common pins are not present on single output models
 Marked with: specific model ordered, date code, job code.

MATERIAL: Units are encapsulated in a low thermal resistance molding compound which has excellent chemical resistance, wide operating temperature range, and good electrical properties under high humidity environments. The encapsulant and outer shell of the unit have UL94V-0 ratings. Lead material is brass with a solder plated surface to allow ease of solderability.

THERMAL DERATING CURVE

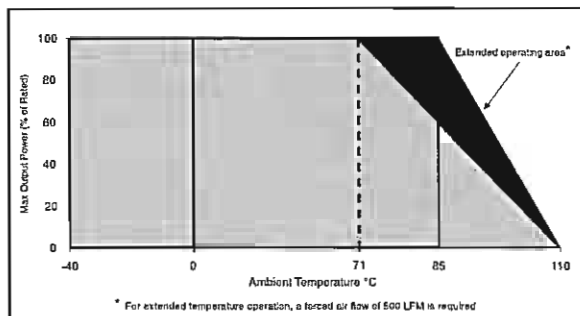

Testing for UL approval was obtained without an input fuse. All UL criteria were met. Although it is good engineering practice to use an input fuse, one is not required for safety reasons.

REMOTE ON/OFF CONTROL

Logic Compatibility CMOS or Open Collector TTL
 EC On Open Circuit or > 2VDC
 EC Off < 1.3VDC
 Shutdown Idle Current <10mA
 Control Common -Vin