

International
IR Rectifier

MBR10..PbF Series

SCHOTTKY RECTIFIER

10 Amp

$I_{F(AV)} = 10\text{Amp}$
 $V_R = 35\text{-}45\text{V}$

Major Ratings and Characteristics

Characteristics	Values	Units
$I_{F(AV)}$ Rectangular waveform	10	A
I_{FRM} @ $T_C = 135^\circ\text{C}$	20	A
V_{RRM}	35-45	V
I_{FSM} @ $t_p = 5\ \mu\text{s}$ sine	1060	A
V_F @ 10Apk, $T_J = 125^\circ\text{C}$	0.57	V
T_J range	-65 to 150	$^\circ\text{C}$

Description/ Features

This Schottky rectifier has been optimized for low reverse leakage at high temperature. The proprietary barrier technology allows for reliable operation up to 150°C junction temperature. Typical applications are in switching power supplies, converters, free-wheeling diodes, and reverse battery protection.

- 150°C T_J operation
- TO-220 and D²Pak packages
- Low forward voltage drop
- High purity, high temperature epoxy encapsulation for enhanced mechanical strength and moisture resistance
- High frequency operation
- Guard ring for enhanced ruggedness and long term reliability
- Lead-Free ("PbF" suffix)

Case Styles

MBR10..PbF



TO-220AC

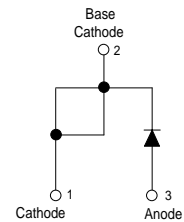

MBR10..PbF Series

Bulletin PD-20863 rev. A 04/06

International
 Rectifier

Voltage Ratings

Part number	MBR1035PbF	MBR1045PbF
V_R Max. DC Reverse Voltage (V)	35	45
V_{RWM} Max. Working Peak Reverse Voltage (V)		

Absolute Maximum Ratings

Parameters	Values	Units	Conditions
$I_{F(AV)}$ Max. Average Forward Current	10	A	@ $T_C = 135^\circ\text{C}$ (Rated V_R)
I_{FRM} Peak Repetitive Forward Current	20	A	Rated V_R , square wave, 20kHz $T_C = 135^\circ\text{C}$
I_{FSM} Non Repetitive Peak Surge Current	1060	A	5 μs Sine or 3 μs Rect. pulse Following any rated load condition and with rated V_{RRM} applied Surge applied at rated load conditions halfwave, single phase, 60Hz
	150		
E_{AS} Non-Repetitive Avalanche Energy	8	mJ	$T_J = 25^\circ\text{C}$, $I_{AS} = 2\text{Amps}$, $L = 4\text{mH}$
I_{AR} Repetitive Avalanche Current	2	A	Current decaying linearly to zero in 1 μsec Frequency limited by T_J max. $V_A = 1.5 \times V_R$ typical

Electrical Specifications

Parameters	Values	Units	Conditions
V_{FM} Max. Forward Voltage Drop (1)	0.84	V	@ 20A $T_J = 25^\circ\text{C}$
	0.57	V	@ 10A $T_J = 125^\circ\text{C}$
	0.72	V	@ 20A $T_J = 125^\circ\text{C}$
I_{RM} Max. Instantaneous Reverse Current (1)	0.1	mA	$T_J = 25^\circ\text{C}$ Rated DC voltage
	15	mA	$T_J = 125^\circ\text{C}$
$V_{F(TO)}$ Threshold Voltage	0.354	V	$T_J = T_J$ max.
r_t Forward Slope Resistance	17.6	m Ω	
C_T Max. Junction Capacitance	600	pF	$V_R = 5V_{DC}$ (test signal range 100Khz to 1Mhz) 25°C
L_S Typical Series Inductance	8.0	nH	Measured from top of terminal to mounting plane
dv/dt Max. Voltage Rate of Change (Rated V_R)	10000	V/ μs	

(1) Pulse Width < 300 μs , Duty Cycle <2%

Thermal-Mechanical Specifications

Parameters	Values	Units	Conditions
T_J Max. Junction Temperature Range	-65 to 150	$^\circ\text{C}$	
T_{stg} Max. Storage Temperature Range	-65 to 175	$^\circ\text{C}$	
R_{thJC} Max. Thermal Resistance Junction to Case	2.0	$^\circ\text{C/W}$	DC operation
R_{thCS} Typical Thermal Resistance Case to Heatsink	0.50	$^\circ\text{C/W}$	Mounting surface, smooth and greased Only for TO-220
wt Approximate Weight	2 (0.07)	g (oz.)	
T Mounting Torque	Min.	6 (5)	Kg-cm (lbf-in)
	Max.	12 (10)	
Marking Device	MBR1045		

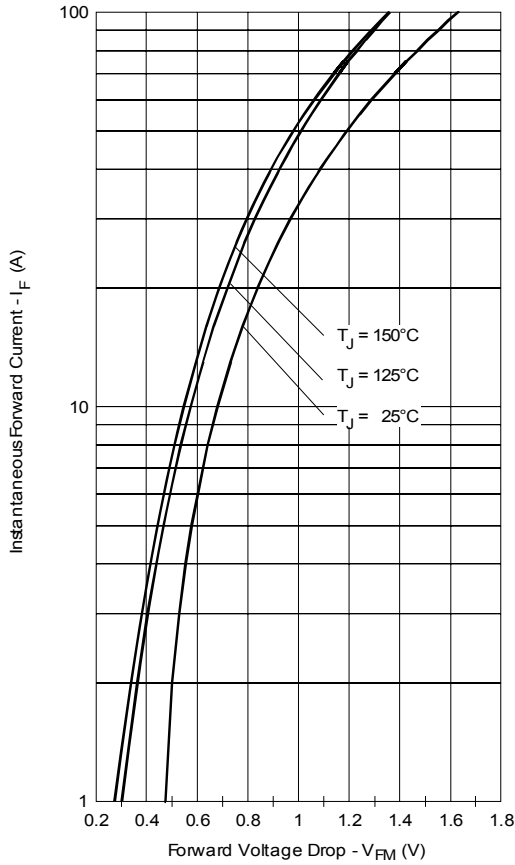

Fig. 1 - Max. Forward Voltage Drop Characteristics

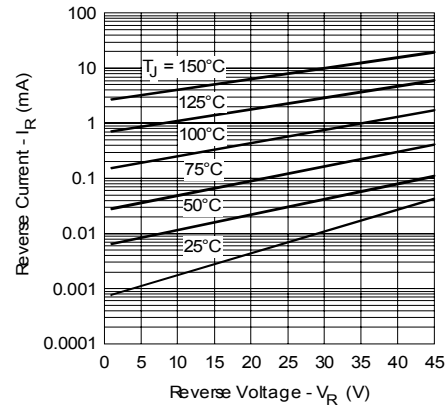

Fig. 2 - Typical Values Of Reverse Current Vs. Reverse Voltage

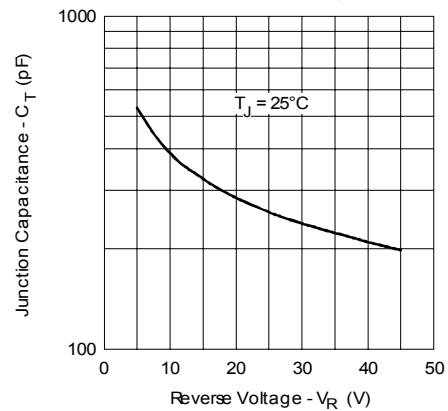

Fig. 3 - Typical Junction Capacitance Vs. Reverse Voltage

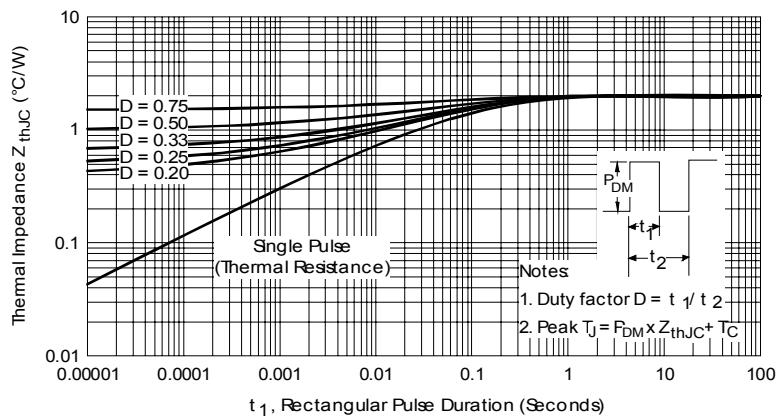

Fig. 4 - Max. Thermal Impedance Z_{thJC} Characteristics

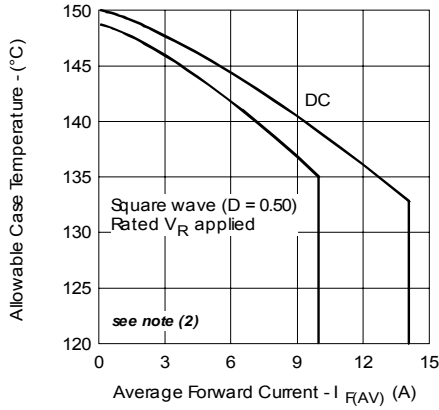

Fig. 5 - Max. Allowable Case Temperature Vs. Average Forward Current

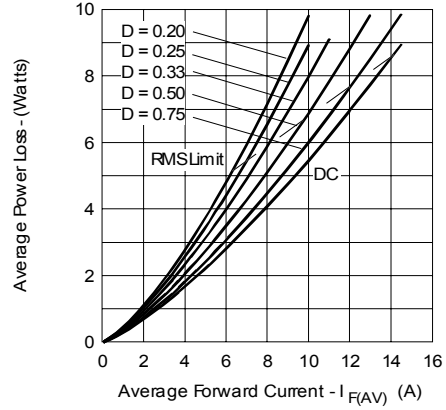

Fig. 6 - Forward Power Loss Characteristics

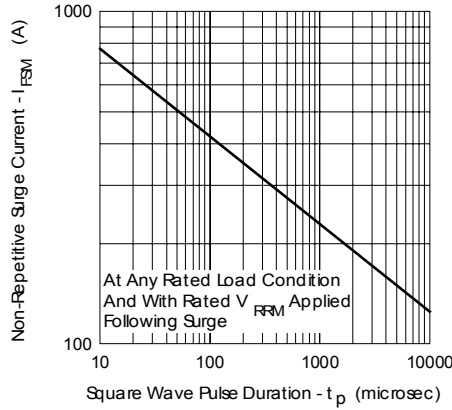
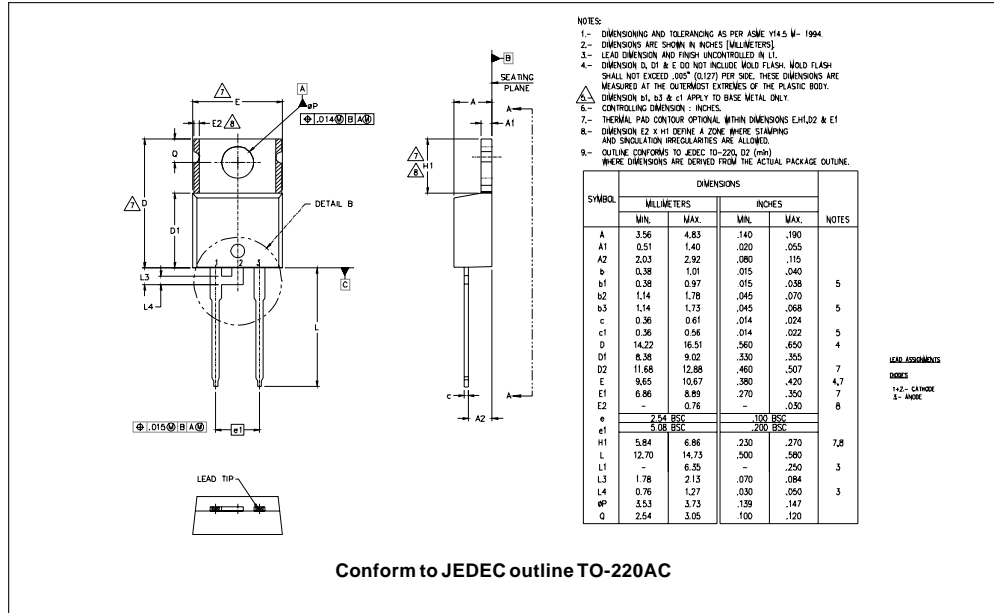

Fig. 7 - Max. Non-Repetitive Surge Current

(2) Formula used: $T_C = T_J - (Pd + Pd_{REV}) \times R_{thJC}$;
 $Pd = \text{Forward Power Loss} = I_{F(AV)} \times V_{FM} @ (I_{F(AV)} / D)$ (see Fig. 6);
 $Pd_{REV} = \text{Inverse Power Loss} = V_{R1} \times I_{R1} (1 - D)$; $I_{R1} @ V_{R1} = \text{rated } V_R$

Outline Table



Part Marking Information

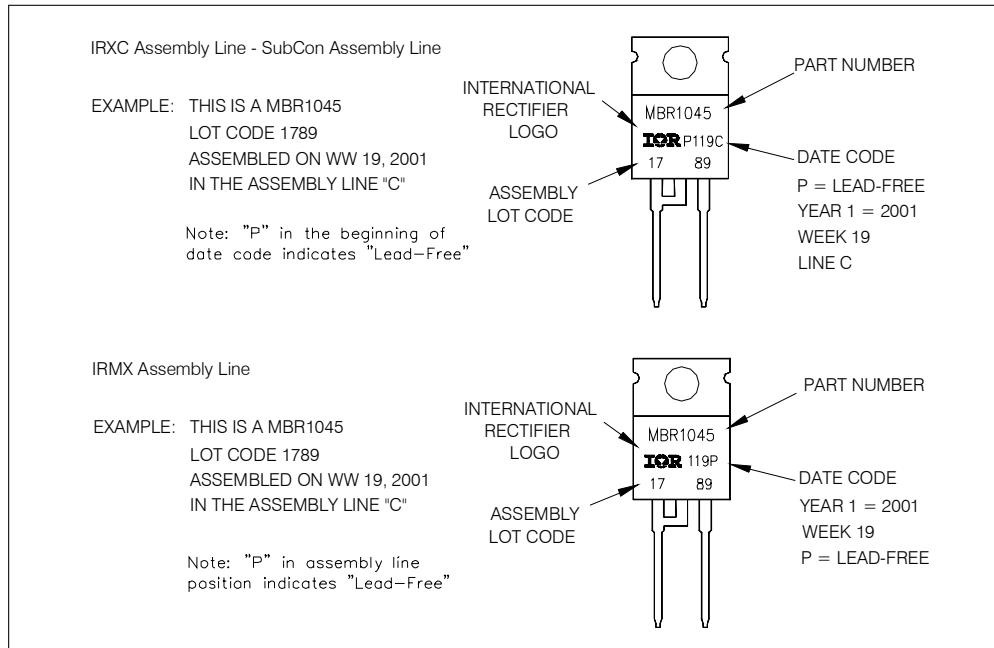

Ordering Information Table

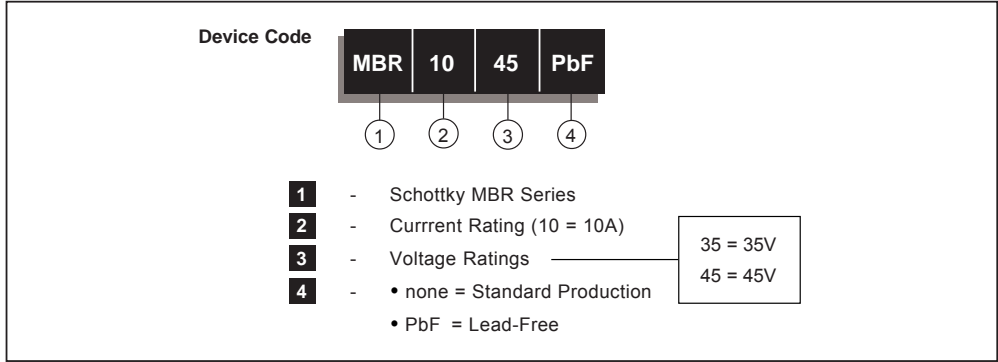

```

MBR1045
*****
* This model has been developed by *
* Wizard SPICE MODEL GENERATOR (1999) *
* (International Rectifier Corporation) *
* Contains Proprietary Information *
*****
* SPICE Model Diode is composed by a *
* simple diode plus paralld VCG2T *
*****
.SUBCKT MBR1045 ANO CAT
D1 ANO 1 DMOD (0.04688)
*Define diode model
.MODEL DMOD D(IS=2.14849701885607E-04A,N=1.50833541375759,BV=52V,
+ IBV=0.431942180477539A,RS= 0.000618816,CJO=1.90645706123736E-08,
+ VJ=2.31227489200037,XTI=2, EG=0.684712841282824)
*****
*Implementation of VCG2T
VX 1 2 DC 0V
R1 2 CAT TRES 1E-6
.MODEL TRES RES(R=1,TC1=-29.9118224426661)
GP1 ANO CAT VALUE={-ABS(I(VX))*(EXP((((-6.195028E-06/-29.91182)*((V(2,CAT)*1E6)/(I(VX)+1E-6)-
1)))+1)*4.475503E-02*ABS(V(ANO,CAT)))-1}}
*****
.ENDS MBR1045

Thermal Model Subcircuit
.SUBCKT MBR1045 5 1

CTHERM1 5 4 1.40E+00
CTHERM2 4 3 1.46E+01
CTHERM3 3 2 9.30E+01
CTHERM4 2 1 1.69E+03

RTHERM1 5 4 5.79E-01
RTHERM2 4 3 7.72E-01
RTHERM1 3 2 4.45E-01
RTHERM1 2 1 1.93E-01

.ENDS MBR1045
    
```

Data and specifications subject to change without notice.
This product has been designed and qualified for Industrial Level and Lead-Free.
Qualification Standards can be found on IR's Web site.

International
IR Rectifier

IR WORLD HEADQUARTERS: 233 Kansas St., El Segundo, California 90245, USA Tel: (310) 252-7105
TAC Fax: (310) 252-7309
Visit us at www.irf.com for sales contact information. 04/06