

V_{DRM} V_{RSM} V_{RRM}	I_D ($T_{case} = 89\text{ °C}$, full conduction) 28 A			
400 V	–	–	SKBZ 28/04	SKCH 28/04
600 V	SKBT 28/06	SKBH 28/06	SKBZ 28/06	SKCH 28/06
800 V	SKBT 28/08	SKBH 28/08	SKBZ 28/08	SKCH 28/08
1200 V	SKBT 28/12	SKBH 28/12	SKBZ 28/12	SKCH 28/12
1400 V	SKBT 28/14	SKBH 28/14	SKBZ 28/14	SKCH 28/14

SEMIPONT® 1 Controllable Bridge Rectifiers

SKBT 28 SKBZ 28
SKBH 28 SKCH 28



Symbol	Conditions	SKBT 28 SKBH 28	SKCH 28 SKBZ 28
I_D	$T_{case} = 85\text{ °C}$, inductive load $T_{amb} = 45\text{ °C}$, chassis ¹⁾ P5A/100 P13A/125 P1A/120	30 A 13 A 15 A 16 A 23 A	
I_{TSM}, I_{FSM}	$T_{vj} = 25\text{ °C}$, 10 ms $T_{vj} = 125\text{ °C}$, 10 ms	320 A 280 A	
i^2t	$T_{vj} = 25\text{ °C}$, 8,3...10 ms $T_{vj} = 125\text{ °C}$, 8,3...10 ms	510 A ² s 390 A ² s	
$(di/dt)_{cr}$	$T_{vj} = 125\text{ °C}$, 10 ms	50 A/ μ s	
$(dv/dt)_{cr}$	$T_{vj} = 125\text{ °C}$, $\frac{2}{3} V_{DRM}$	500 V/ μ s	
I_H	$T_{vj} = 25\text{ °C}$, typ./max.	50 mA/150 mA	
I_L	$T_{vj} = 25\text{ °C}$, typ./max.	100 mA/300 mA	
V_T	$T_{vj} = 25\text{ °C}$; $I_T = 75\text{ A}$	2,25 V	
$V_{T(TO)}$	$T_{vj} = 125\text{ °C}$	1,0 V	
r_T	$T_{vj} = 125\text{ °C}$	16 m Ω	
I_D	$T_{vj} = 125\text{ °C}$; V_{DRM} , V_{RRM}	8 mA	
V_{GT}	$T_{vj} = 25\text{ °C}$; $V_D = 6\text{ V}$	2 V	
I_{GT}	$T_{vj} = 25\text{ °C}$; $V_D = 6\text{ V}$	100 mA	
V_{GD}	$T_{vj} = 125\text{ °C}$; $V_D = 6\text{ V}$	0,25 V	
R_{thjc}	per thyristor/diode	1,8 °C/W	
	total	0,45 °C/W	
R_{thch}	total	0,1 °C/W	
R_{thja}	total ²⁾	15 °C/W	
T_{vj} , T_{stg}		– 40...+ 125 °C	
V_{isol}	a.c. 50...60 Hz; r.m.s.; 1 s / 1 min	3600 V~ / 3000 V~	
M_1	case to heatsink; SI units/US units	2 Nm/18 lb. in. \pm 15 %	
w		66 g	
Case		SKBT: G 22 SKBH: G 23	SKBZ: G 24 SKCH: G 25

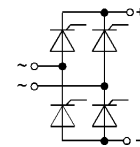

SKBT

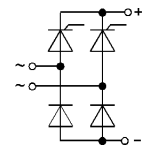

SKBH

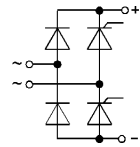

SKBZ

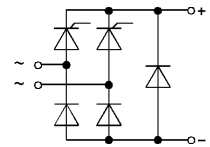

SKCH

Features

- Sturdy isolated metal baseplate
- Fast-on terminals with solder tips
- Suitable for wave soldering
- High surge current rating
- UL recognized, file no. E 63 532

Typical Applications

- Controllable single-phase rectifiers
- DC power supplies
- DC motor controllers
- DC motor field controllers

¹⁾ Painted metal sheet of minimum 250 x 250 x 1 mm³: $R_{thca} = 1,85\text{ °C/W}$

²⁾ Freely suspended or mounted on an insulator

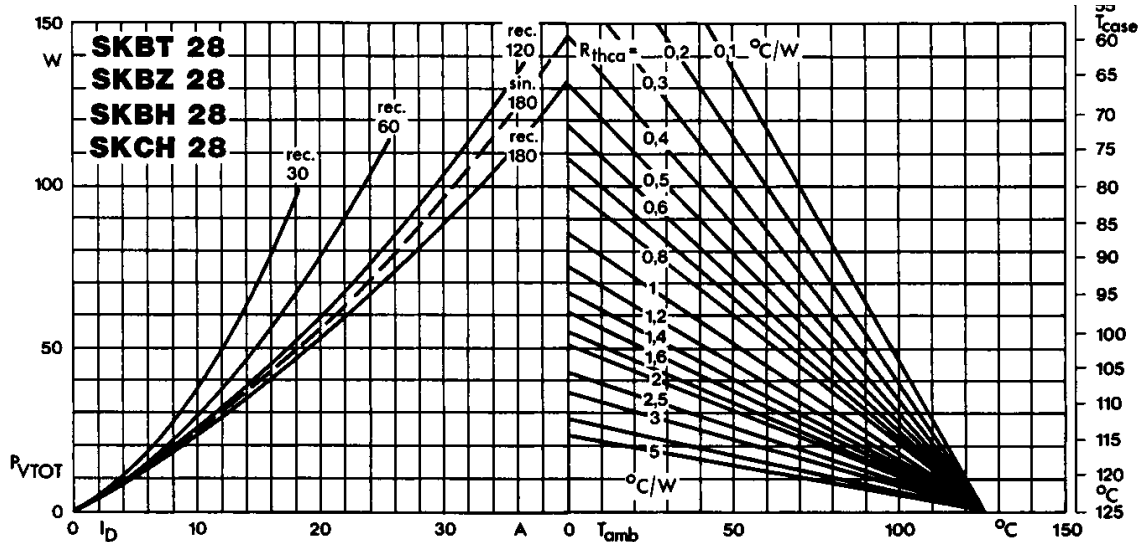

Fig. 4 Power dissipation vs. output current and case temperature

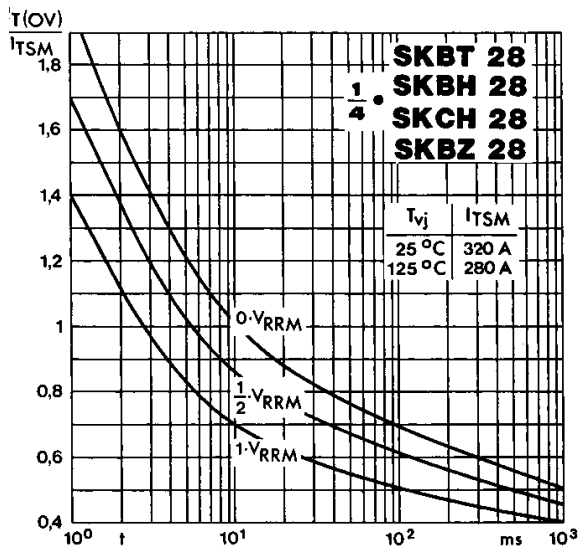

Fig. 5 Surge overload current vs. time

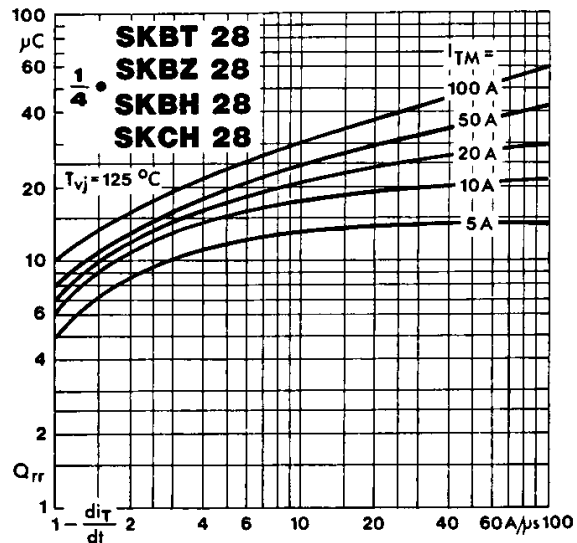

Fig. 8 Recovered charge vs. current decrease

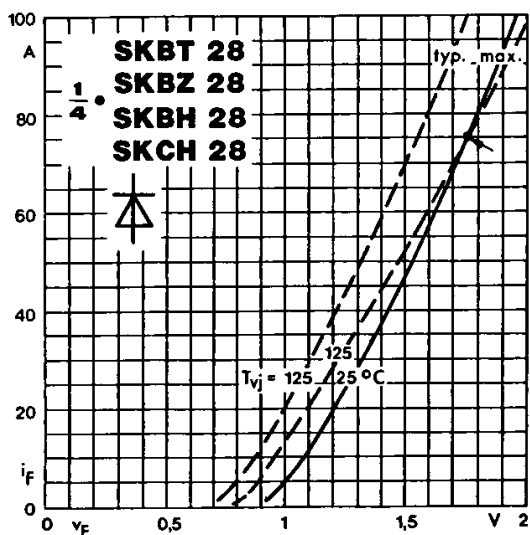

Fig. 9 Forward characteristics of a single diode

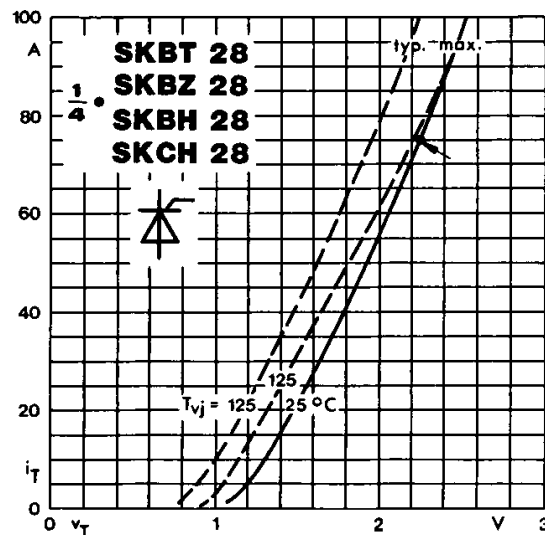

Fig. 10 On-state characteristics of a single thyristor

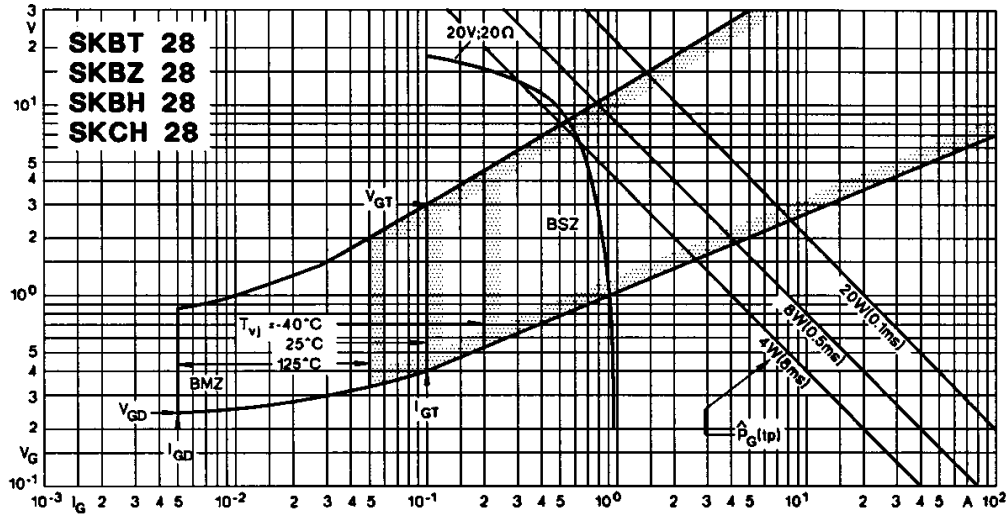

Fig. 11 Gate trigger characteristics

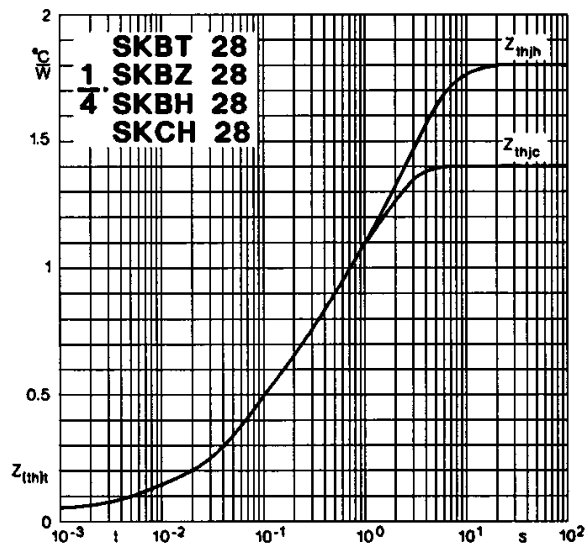
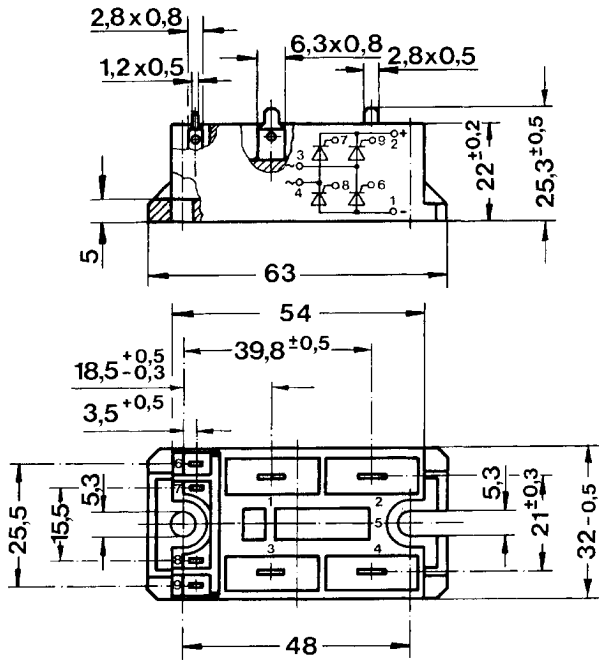
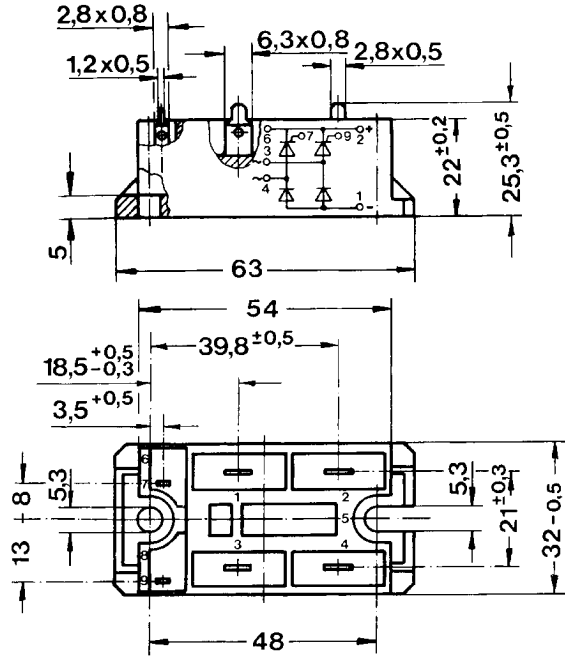

Fig. 12 Transient thermal impedance vs. time

SKBT 28Case G 22
SEMIPONT® 1

Dimensions in mm

SKBH 28Case G 23
SEMIPONT® 1

Dimensions in mm

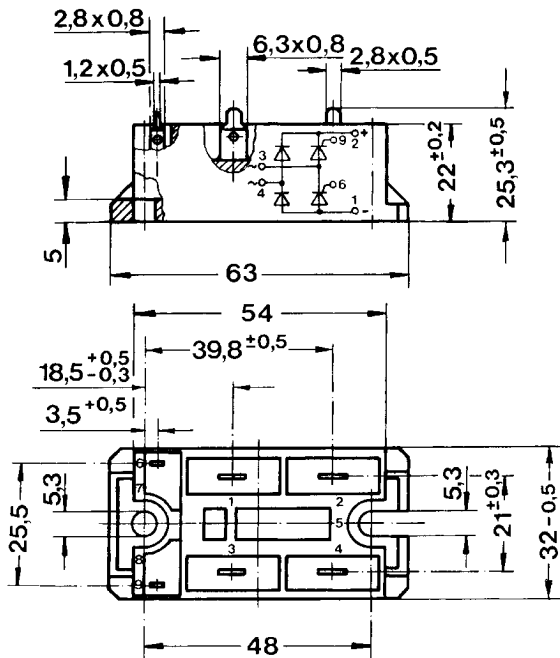
SKBZ 28Case G 24
SEMIPONT® 1

Dimensions in mm

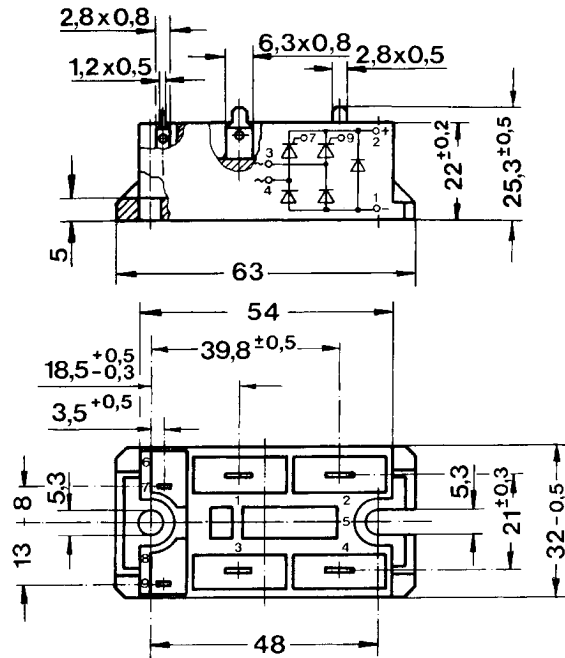
SKCH 28Case G 25
SEMIPONT® 1

Dimensions in mm