

ALL RIGHTS RESERVED. NO PORTION OF THIS PUBLICATION, WHETHER IN WHOLE OR IN PART CAN BE REPRODUCED WITHOUT THE EXPRESS WRITTEN CONSENT OF SPC TECHNOLOGY.

REVISIONS			DOC. NO. SPC-F004 * Effective: 12/21/98 * DCP No: 680					
DCP #	REV	DESCRIPTION	DRAWN	DATE	CHECKD	DATE	APPRVD	DATE
1002	A	RELEASED	HYD	4/11/02	JWM	4/12/02	JC	4/12/02

FEATURES & MECHANICAL DATA:

- Case: Metal, electrically isolated metal case for maximum heat dissipation
- Terminals: Plated 0.25 Inches Quick Disconnect
- Surge overload rating to 400 Amperes
- Weight: 1 ounce, 30 grams
- Mounting Position: Any

Maximum Ratings and Electrical Characteristics

Rating @ 25°C ambient temperature unless otherwise specified. Single phase, half wave, 60Hz, resistive or inductive load.
For capacitive load, derate current by 20 %

CHARACTERISTICS	MULTICOMP TYPE NO.						
	MCCM2500 MCCM5000	MCCM2501 MCCM3501	MCCM2502 MCCM3502 MCCM5002	MCCM2504 MCCM3504	MCCM2506 MCCM3506 MCCM5006	MCCM2508 MCCM3508	MCCM25010 MCCM35010 MCCM50010
Max. Recurrent Peak Reverse Voltage (V)	50	100	200	400	600	800	1000
Max. RMS Input Voltage (V)	35	70	140	280	420	560	800
Max. DC Blocking Voltage (V)	50	100	200	400	600	800	1000

Multicomp Type No.	Max. Average Forward Current For Resistive Load @ TC=55°C	Non-repetitive Peak Forward Surge Current @ Rated Load	I ² t Rating for fusing (t < 8.3ms) (A ² S)	Max. Peak Forward Voltage Per Bridge Element at Specified Current	
				Current (A)	Voltage (V)
MCCM2500	25 A	300 A	374	12.5	1.2
MCCM2501					
MCCM2502					
MCCM2504					
MCCM2506					
MCCM2508					
MCCM25010	35 A	400 A	664	17.5	1.2
MCCM3501					
MCCM3502					
MCCM3504					
MCCM3506					
MCCM3508					
MCCM35010	50 A	500 A	750	25	1.2
MCCM5000					
MCCM5002					
MCCM5006					
MCCM50010					

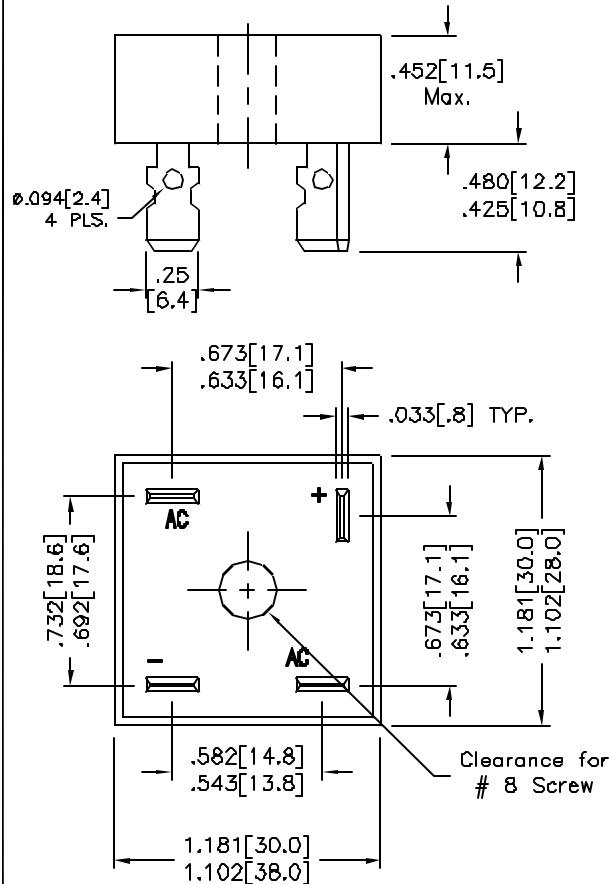

- Max. reverse leakage current @ rated DC blocking voltage: 10 μA
- Typical thermal resistance (see curve) R θJC: 2.5°C/W
- Operating temperature range T_J & storage temperature range T_{STG}: -55°C ~ +150°C

SPC-F004.DWG

DISCLAIMER:
ALL STATEMENTS AND TECHNICAL INFORMATION CONTAINED HEREIN ARE BASED UPON INFORMATION AND/OR TESTS WE BELIEVE TO BE ACCURATE AND RELIABLE. SINCE CONDITIONS OF USE ARE BEYOND OUR CONTROL, THE USER SHALL DETERMINE THE SUITABILITY OF THE PRODUCT FOR THE INTENDED USE AND ASSUME ALL RISK AND LIABILITY WHATSOEVER IN CONNECTION THEREWITH.



UNLESS OTHERWISE SPECIFIED, DIMENSIONS ARE FOR REFERENCE PURPOSES ONLY.

DRAWN BY:	DATE:
HISHAM QDISH	4/11/02
CHECKED BY:	DATE:
JEFF MCVICKER	4/12/02
APPROVED BY:	DATE:
JOHN COLE	4/12/02

DRAWING TITLE: HIGH CURRENT SILICON BRIDGE RECTIFIER			
SIZE	DWG. NO.	ELECTRONIC FILE	REV
A	TA-328	TA-328.DWG	A
SCALE: NTS		U.O.M.: INCHES [mm]	SHEET: 1 OF 2

RATING AND CHARACTERISTIC CURVES

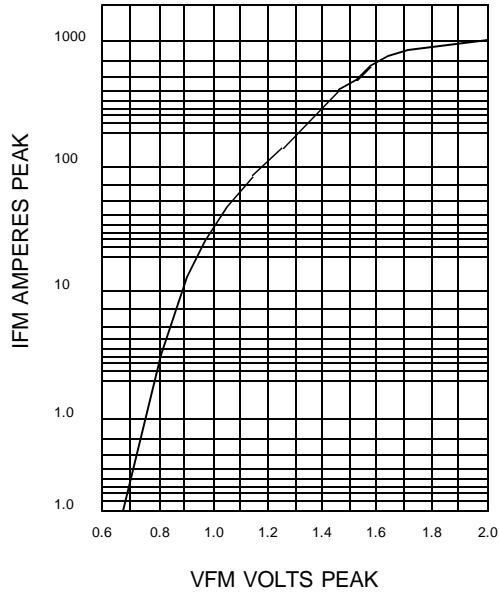

TYPICAL INSTANTANEOUS FORWARD CHARACTERISTICS AT $T_j=25^\circ\text{C}$

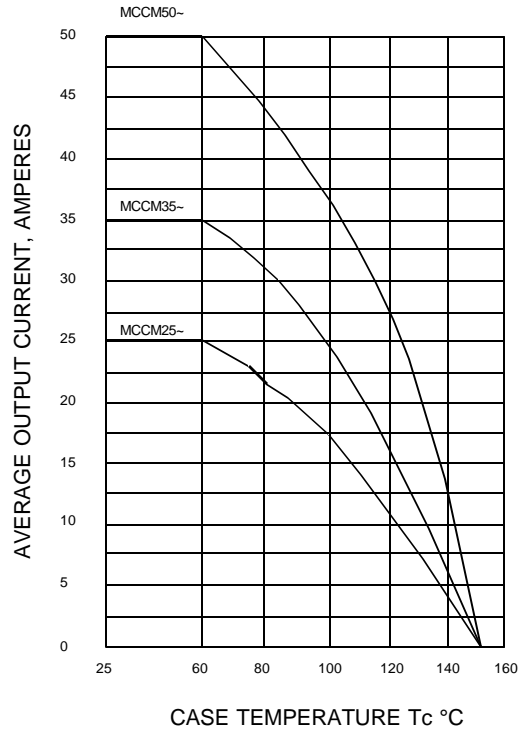

OUTPUT CURRENT AS, CASE TEMPERATURE RESISTIVE OR INDUCTIVE LOAD $T_j=150^\circ\text{C}$

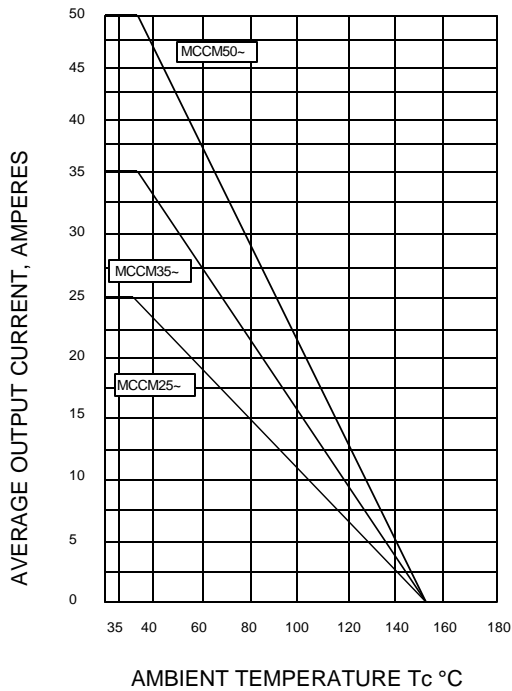

OUTPUT CURRENT VS. AMBIENT TEMPERATURE RESISTIVE OR INDUCTIVE LOAD BRIDGE MOUNTED ON A 8" X 8" ALUMINUM PLATE 25" THICK

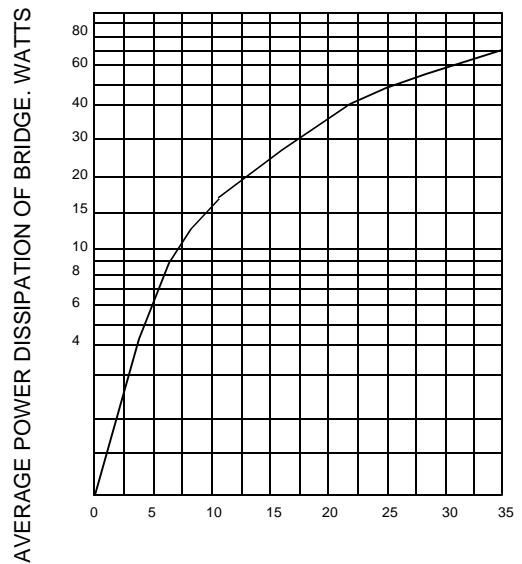

POWER DISSIPATION VS. AVERAGE OUTPUT CURRENT RESISTIVE OR INDUCTIVE LOAD, $T_j=150^\circ\text{C}$

SIZE A	DWG. NO. TA-328	ELECTRONIC FILE TA-328.DWG	REV A
SCALE: NTS		U.O.M.: INCHES [mm]	SHEET: 2 OF 2