

PROTECTION PRODUCTS

Description

RailClamps are surge rated diode arrays designed to protect high speed data interfaces. The SR series has been specifically designed to protect sensitive components which are connected to data and transmission lines from overvoltage caused by electrostatic discharge (**ESD**), electrical fast transients (**EFT**), and **lightning**.

The unique design of the SRDA series devices incorporates surge rated, low capacitance steering diodes and a TVS diode in a single package. During transient conditions, the steering diodes direct the transient to either the positive side of the power supply line or to ground. The internal TVS diode prevents over-voltage on the power line, protecting any downstream components.

The low capacitance array configuration allows the user to protect six high-speed data or transmission lines. The low inductance construction minimizes voltage overshoot during high current surges.

Features

- ◆ Transient protection for high-speed data lines to **IEC 61000-4-2 (ESD) ±15kV (air), ±8kV (contact)**
IEC 61000-4-4 (EFT) 40A (5/50ns)
IEC 61000-4-5 (Lightning) 24A (8/20µs)
- ◆ Array of surge rated diodes with internal TVS diode
- ◆ Protects six I/O lines and power supply line
- ◆ Low capacitance (<15pF) for high-speed interfaces
- ◆ Low operating & clamping voltages
- ◆ Solid-state technology

Mechanical Characteristics

- ◆ JEDEC SO-8 package
- ◆ Pb-Free, Halogen Free, RoHS/WEEE Compliant
- ◆ Molding compound flammability rating: UL 94V-0
- ◆ Marking : Part number, date code, logo
- ◆ Packaging : Tape and Reel

Applications

- ◆ USB Power & Data Line Protection
- ◆ T1/E1 secondary IC Side Protection
- ◆ Token Ring
- ◆ HDSL, SDSL secondary IC Side Protection
- ◆ Video Line Protection
- ◆ Microcontroller Input Protection
- ◆ Base stations
- ◆ I²C Bus Protection

Circuit Diagram

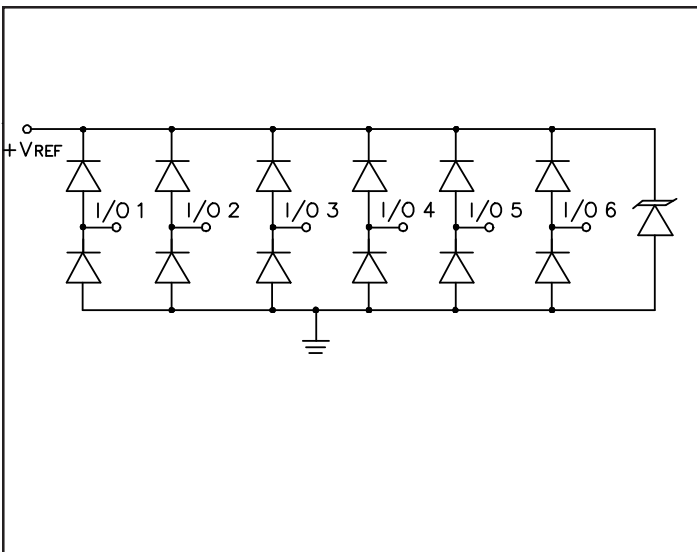

Schematic and PIN Configuration

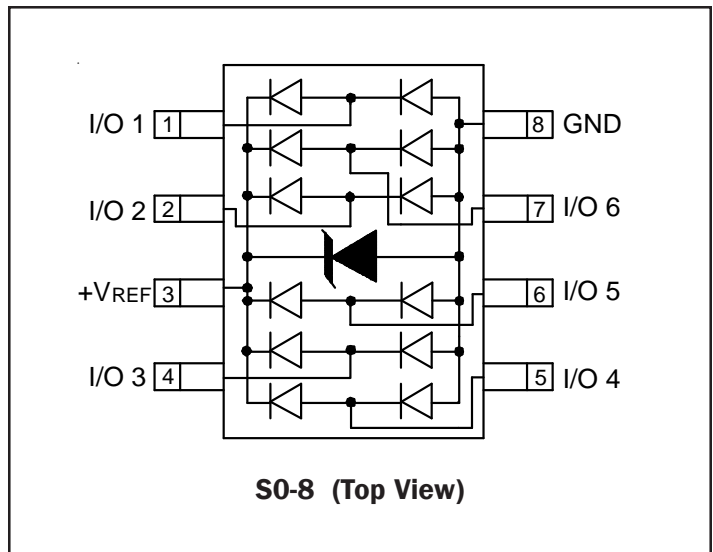

PROTECTION PRODUCTS
Absolute Maximum Rating

Rating	Symbol	Value	Units
Peak Pulse Power ($t_p = 8/20\mu s$)	P_{pk}	500	Watts
Peak Forward Voltage ($I_F = 1A, t_p=8/20\mu s$)	V_{FP}	1.5	V
Operating Temperature	T_J	-55 to +125	°C
Storage Temperature	T_{STG}	-55 to +150	°C

Electrical Characteristics (T=25°C)

SRDA3.3-6						
Parameter	Symbol	Conditions	Minimum	Typical	Maximum	Units
Reverse Stand-Off Voltage	V_{RWM}				3.3	V
Punch-Through Voltage	V_{PT}	$I_{PT} = 2\mu A$	3.5			V
Snap-Back Voltage	V_{SB}	$I_{SB} = 50mA$	2.8			V
Reverse Leakage Current	I_R	$V_{RWM} = 3.3V, T=25^\circ C$			1	μA
Clamping Voltage	V_C	$I_{PP} = 1A, t_p = 8/20\mu s$			5.3	V
Clamping Voltage	V_C	$I_{PP} = 10A, t_p = 8/20\mu s$			10	V
Clamping Voltage	V_C	$I_{PP} = 25A, t_p = 8/20\mu s$			15	V
Peak Pulse Current	I_{PP}	$t_p = 8/20\mu s$			25	A
Junction Capacitance	C_j	Between I/O pins and Ground $V_R = 0V, f = 1MHz$		8	15	pF
		Between I/O pins $V_R = 0V, f = 1MHz$		4		pF

Note:

(1) The SRDA3.3-6 is constructed using Semtech's proprietary EPD process technology. See applications section for more information.

PROTECTION PRODUCTS
Electrical Characteristics (continued)

SRDA05-6						
Parameter	Symbol	Conditions	Minimum	Typical	Maximum	Units
Reverse Stand-Off Voltage	V_{RWM}				5	V
Reverse Breakdown Voltage	V_{BR}	$I_t = 1mA$	6			V
Reverse Leakage Current	I_R	$V_{RWM} = 5V, T=25^{\circ}C$			10	μA
Clamping Voltage	V_C	$I_{PP} = 1A, t_p = 8/20\mu s$			9.8	V
Clamping Voltage	V_C	$I_{PP} = 10A, t_p = 8/20\mu s$			12	V
Clamping Voltage	V_C	$I_{PP} = 25A, t_p = 8/20\mu s$			20	V
Peak Pulse Current	I_{PP}	$t_p = 8/20\mu s$			25	A
Junction Capacitance	C_j	Between I/O pins and Ground $V_R = 0V, f = 1MHz$		8	15	pF
		Between I/O pins $V_R = 0V, f = 1MHz$		4		pF

PROTECTION PRODUCTS

Typical Characteristics

Non-Repetitive Peak Pulse Power vs. Pulse Time

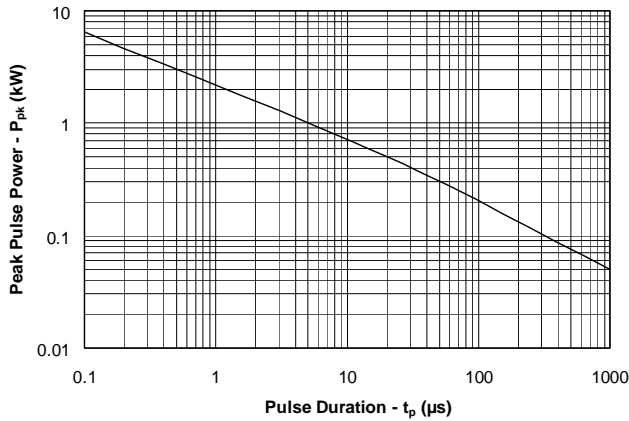

Power Derating Curve

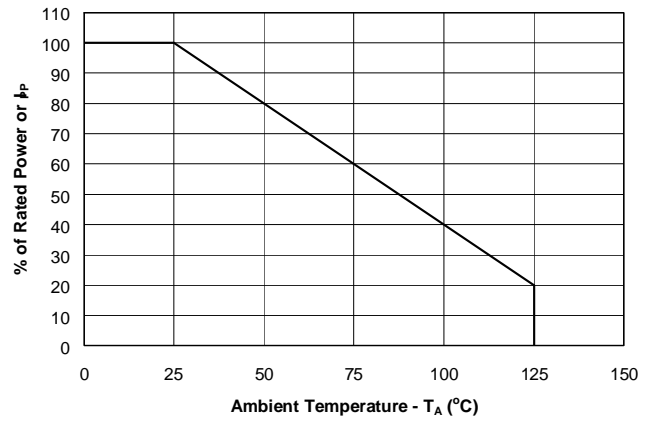

Pulse Waveform

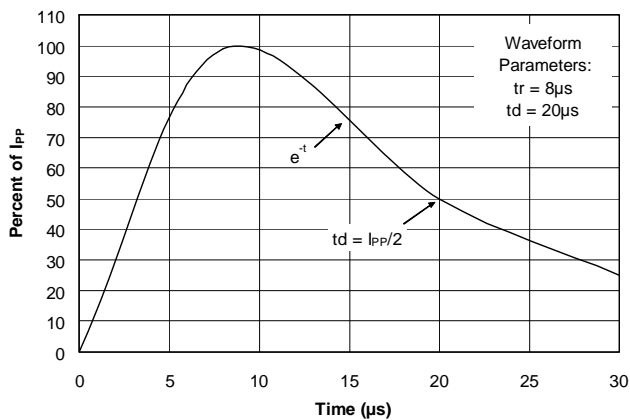

Clamping Voltage vs. Peak Pulse Current

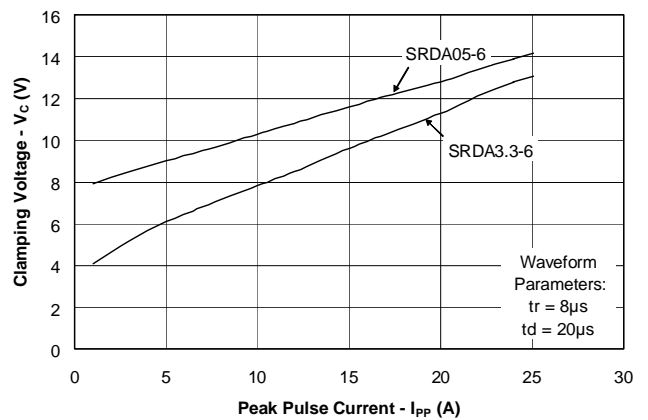

Variation of Capacitance vs. Reverse Voltage

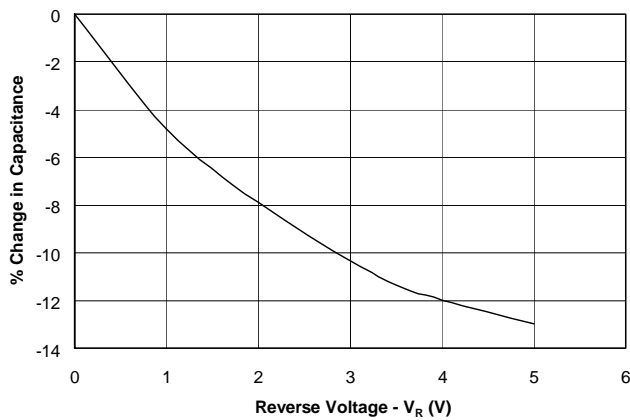

Forward Voltage vs. Forward Current

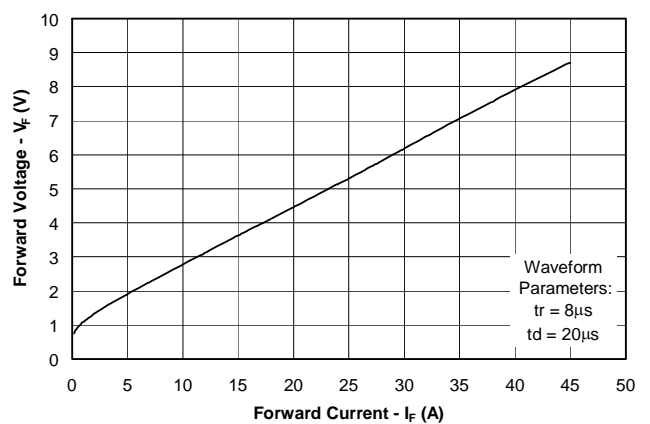

PROTECTION PRODUCTS

Applications Information

Device Connection Options for Protection of Six High-Speed Lines

The SRDA TVS is designed to protect four data lines from transient overvoltages by clamping them to a fixed reference. When the voltage on the protected line exceeds the reference voltage (plus diode V_f) the steering diodes are forward biased, conducting the transient current away from the sensitive circuitry. Data lines are connected at pins 1, 2, 4, 5, 6 and 7. The negative reference is connected at pin 8. These pins should be connected directly to a ground plane on the board for best results. The path length is kept as short as possible to minimize parasitic inductance. The positive reference is connected at pins 2 and 3.

In the case of the SRDA3.3-6, pins 2 and 3 are connected internally to the cathode of the low voltage TVS. It is not recommended that these pins be directly connected to a DC source greater than the snap-back voltage (V_{SB}) as the device can latch on as described below.

EPD TVS Characteristics

These devices are constructed using Semtech's proprietary EPD technology. By utilizing the EPD technology, the SRDA3.3-6 can effectively operate at 3.3V while maintaining excellent electrical characteristics.

The EPD TVS employs a complex npn structure in contrast to the pn structure normally found in traditional silicon-avalanche TVS diodes. Since the EPD TVS devices use a 4-layer structure, they exhibit a slightly different IV characteristic curve when compared to conventional devices. During normal operation, the device represents a high-impedance to the circuit up to the device working voltage (V_{RWM}). During an ESD event, the device will begin to conduct and will enter a low impedance state when the punch through voltage (V_{PT}) is exceeded. Unlike a conventional device, the low voltage TVS will exhibit a slight negative resistance characteristic as it conducts current. This characteristic aids in lowering the clamping voltage of the device, but must be considered in applications where DC voltages are present.

When the TVS is conducting current, it will exhibit a slight "snap-back" or negative resistance characteristics due to its structure. This point is defined on the

Data Line Protection Using Internal TVS Diode as Reference

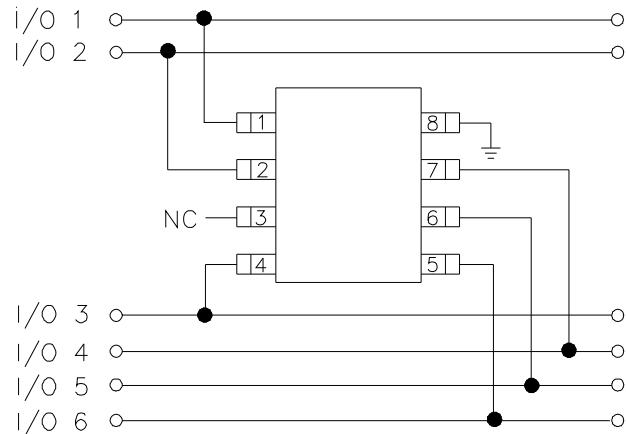

EPD TVS IV Characteristic Curve

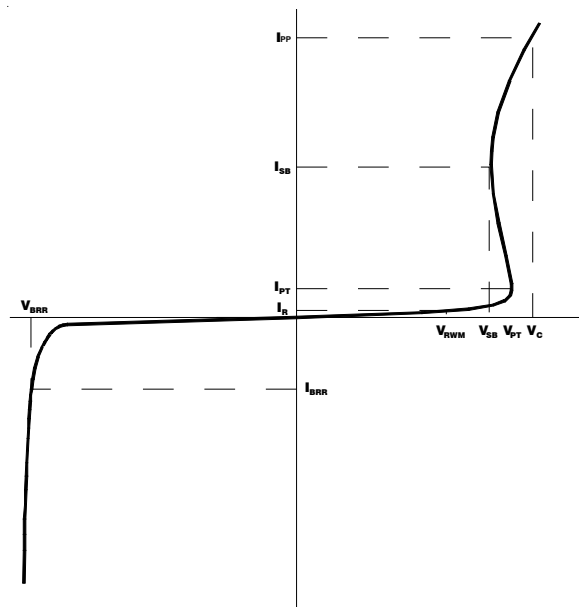

curve by the snap-back voltage (V_{SB}) and snap-back current (I_{SB}). To return to a non-conducting state, the current through the device must fall below the I_{SB} (approximately $<50\text{mA}$) and the voltage must fall below the V_{SB} (normally 2.8 volts for a 3.3V device). If a 3.3V TVS is connected to 3.3V DC source, it will never fall below the snap-back voltage of 2.8V and will therefore stay in a conducting state.

PROTECTION PRODUCTS

Applications Information (continued)

approximation, the clamping voltage due to the characteristics of the protection diodes is given by:

$$V_C = V_{CC} + V_F \quad (\text{for positive duration pulses})$$

$$V_C = -V_F \quad (\text{for negative duration pulses})$$

However, for fast rise time transient events, the effects of parasitic inductance must also be considered as shown in Figure 2. Therefore, the actual clamping voltage seen by the protected circuit will be:

$$V_C = V_{CC} + V_F + L_P \frac{di_{ESD}}{dt} \quad (\text{for positive duration pulses})$$

$$V_C = -V_F - L_G \frac{di_{ESD}}{dt} \quad (\text{for negative duration pulses})$$

ESD current reaches a peak amplitude of 30A in 1ns for a level 4 ESD contact discharge per IEC 1000-4-2. Therefore, the voltage overshoot due to 1nH of series inductance is:

$$V_P = L_P \frac{di_{ESD}}{dt} = 1 \times 10^{-9} (30 / 1 \times 10^{-9}) = 30V$$

Example:

Consider a $V_{CC} = 5V$, a typical V_F of 30V (at 30A) for the steering diode and a series trace inductance of 10nH. The clamping voltage seen by the protected IC for a positive 8kV (30A) ESD pulse will be:

$$V_C = 5V + 30V + (10nH \times 30V/nH) = 335V$$

This does not take into account that the ESD current is directed into the supply rail, potentially damaging any components that are attached to that rail. Also note the high V_F of the discrete diode. It is not uncommon for the V_F of discrete diodes to exceed the damage threshold of the protected IC. This is due to the relatively small junction area of typical discrete components. It is also possible that the power dissipation capability of the discrete diode will be exceeded, thus destroying the device.

The RailClamp is designed to overcome the inherent disadvantages of using discrete signal diodes for ESD suppression. The RailClamp's integrated TVS diode helps to mitigate the effects of parasitic inductance in the power supply connection. During an ESD event,

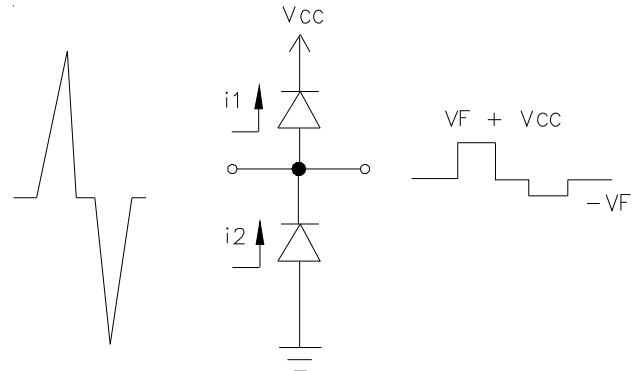

Figure 1 - "Rail-To-Rail" Protection Topology (First Approximation)

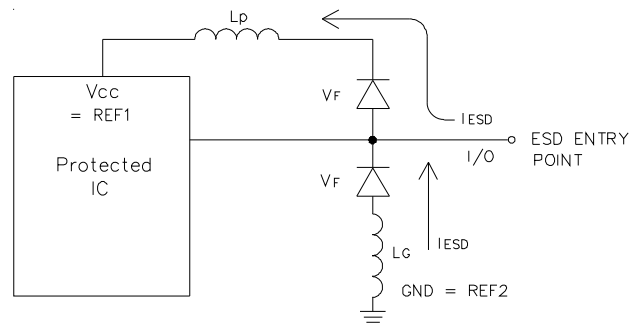

Figure 2 - The Effects of Parasitic Inductance When Using Discrete Components to Implement Rail-To-Rail Protection

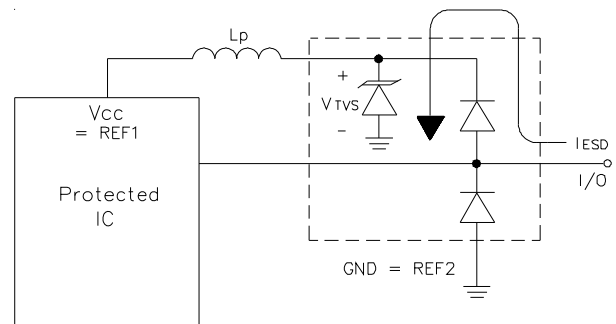

Figure 3 - Rail-To-Rail Protection Using RailClamp TVS Arrays

PROTECTION PRODUCTS**Applications Information (continued)**

the current will be directed through the integrated TVS diode to ground. The total clamping voltage seen by the protected IC due to this path will be:

$$V_C = V_{F(\text{RailClamp})} + V_{\text{TVS}}$$

This is given in the data sheet as the rated clamping voltage of the device. For an SRDA05-6 the typical clamping voltage is <16V at $I_{PP}=30A$. The diodes internal to the RailClamp are low capacitance, fast switching devices that are rated to handle high transient currents and maintain excellent forward voltage characteristics.

Using the RailClamp does not negate the need for good board layout. All other inductive paths must be considered. The connection between the positive supply and the SRDA and from the ground plane to the SRDA must be kept as short as possible. The path between the SRDA and the protected line must also be minimized. The protected lines should be routed directly to the SRDA. Placement of the SRDA on the PC board is also critical for effective ESD protection. The device should be placed as close as possible to the input connector. The reason for this is twofold. First, inductance resists change in current flow. If a significant inductance exists between the connector and the TVS, the ESD current will be directed elsewhere (lower resistance path) in the system. Second, the effects of radiated emissions and transient coupling can cause upset to other areas of the board even if there is no direct path to the connector. By placing the TVS close to the connector it will divert the ESD current immediately and absorb the ESD energy before it can be coupled into nearby traces.

(Reference Semtech application note SI99-01 for further information on board layout)

Matte Tin Lead Finish

Matte tin has become the industry standard lead-free replacement for SnPb lead finishes. A matte tin finish is composed of 100% tin solder with large grains. Since the solder volume on the leads is small compared to the solder paste volume that is placed on the land pattern of the PCB, the reflow profile will be

determined by the requirements of the solder paste. Therefore, these devices are compatible with both lead-free and SnPb assembly techniques. In addition, unlike other lead-free compositions, matte tin does not have any added alloys that can cause degradation of the solder joint.

PROTECTION PRODUCTS

Outline Drawing - S0-8

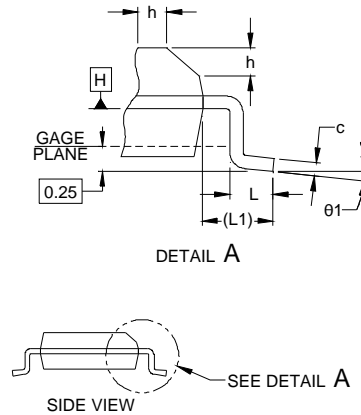
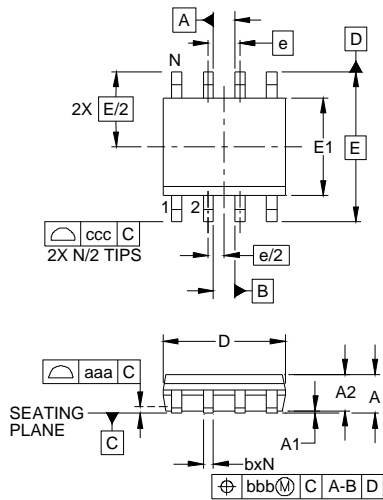

DIM	INCHES			MILLIMETERS		
	MIN	NOM	MAX	MIN	NOM	MAX
A	.053	-	.069	1.35	-	1.75
A1	.004	-	.010	0.10	-	0.25
A2	.049	-	.065	1.25	-	1.65
b	.012	-	.020	0.31	-	0.51
c	.007	-	.010	0.17	-	0.25
D	.189	.193	.197	4.80	4.90	5.00
E1	.150	.154	.157	3.80	3.90	4.00
E	.236 BSC			6.00 BSC		
e	.050 BSC			1.27 BSC		
h	.010	-	.020	0.25	-	0.50
L	.016	.028	.041	0.40	0.72	1.04
L1	(0.041)			(1.04)		
N	8			8		
theta 1	0°	-	8°	0°	-	8°
aaa	.004			0.10		
bbb	.010			0.25		
ccc	.008			0.20		

NOTES:

1. CONTROLLING DIMENSIONS ARE IN MILLIMETERS (ANGLES IN DEGREES).
2. DATUMS **-A-** AND **-B-** TO BE DETERMINED AT DATUM PLANE **-H-**
3. DIMENSIONS "E1" AND "D" DO NOT INCLUDE MOLD FLASH, PROTRUSIONS OR GATE BURRS.
4. REFERENCE JEDEC STD MS-012, VARIATION AA.

Land Pattern - S0-8

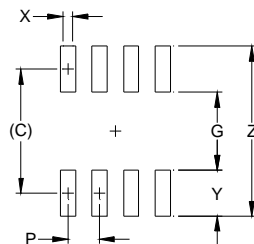

DIM	DIMENSIONS	
	INCHES	MILLIMETERS
C	(.205)	(5.20)
G	.118	3.00
P	.050	1.27
X	.024	0.60
Y	.087	2.20
Z	.291	7.40

NOTES:

1. THIS LAND PATTERN IS FOR REFERENCE PURPOSES ONLY. CONSULT YOUR MANUFACTURING GROUP TO ENSURE YOUR COMPANY'S MANUFACTURING GUIDELINES ARE MET.
2. REFERENCE IPC-SM-782A, RLP NO. 300A.

PROTECTION PRODUCTS

Marking

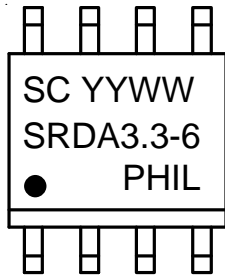

SRDA3.3-6

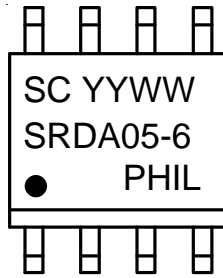

SRDA05-6

YYWW = Date Code

Ordering Information

Part Number	Working Voltage	Qty/Reel	Reel Size
SRDA3.3-6.TBT	3.3V	500	7 Inch
SRDA05-6.TBT	5V	500	7 Inch

Tape and Reel Specification

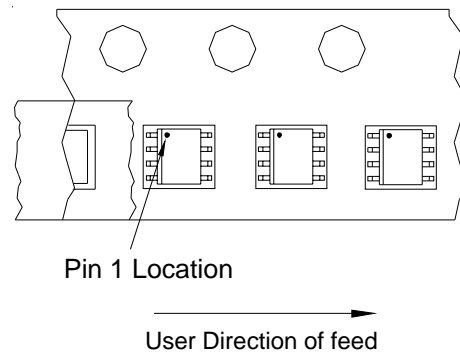
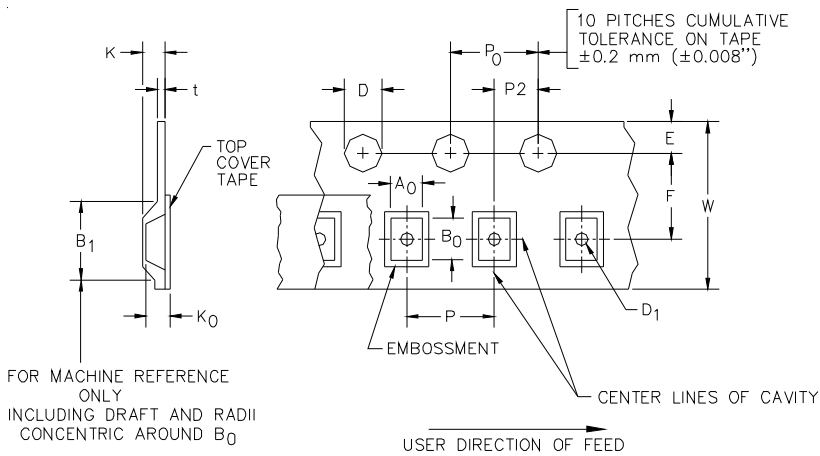

Device Orientation in Tape

A0	B0	K0
6.50 +/-0.20 mm	5.40 +/-0.20 mm	2.00 +/-0.10 mm

Tape Width	B, (Max)	D	D1	E	F	K (MAX)	P	P0	P2	T(MAX)	W
12 mm	8.2 mm	1.5 + 0.1 mm - 0.0 mm	1.5 mm	1.750±.10 mm	5.5±0.05 mm	4.5 mm	4.0±0.1 mm	4.0±0.1 mm	2.0±0.05 mm	0.4 mm	12.0 mm ±0.3

Contact Information

Semtech Corporation
 Protection Products Division
 200 Flynn Road, Camarillo, CA 93012
 Phone: (805)498-2111 FAX (805)498-3804