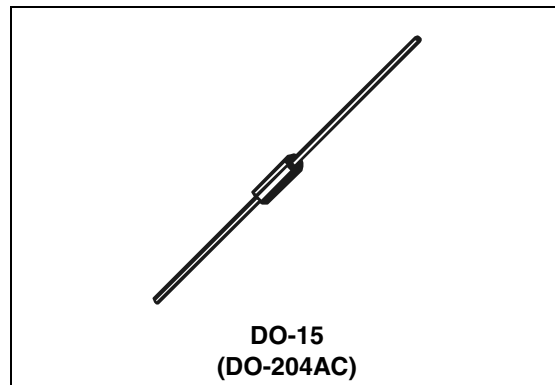

**FEATURES**

- Peak pulse power: 600 W (10/1000  $\mu$ s )
- Stand-off voltage range 6.8 to 440V
- Unidirectional and Bidirectional types
- Low clamping factor
- Fast response time
- UL recognized

**DESCRIPTION**

Transil diodes provide high overvoltage protection by clamping action. Their instantaneous response to transient overvoltages makes them particularly suited to protect voltage sensitive devices such as MOS Technology and low voltage supplied IC's.

**Table 1: Order Codes**

Part Number	Marking
P6KExxxx	See page 2

**Table 2: Absolute Maximum Ratings** ( $T_{amb} = 25^{\circ}\text{C}$ )

Symbol	Parameter	Value	Unit
$P_{PP}$	Peak pulse power dissipation (see note 1)	$T_j \text{ initial} = T_{amb}$	600 W
$P$	Power dissipation on infinite heatsink	$T_{amb} = 75^{\circ}\text{C}$	5 W
$I_{FSM}$	Non repetitive surge peak forward current	$t_p = 10 \text{ ms}$ $T_j \text{ initial} = T_{amb}$	100 A
$T_{stg}$ $T_j$	Storage temperature range Maximum junction temperature		-65 to 175 175 $^{\circ}\text{C}$
$T_L$	Maximum lead temperature for soldering during 10 s at 5mm from case		230 $^{\circ}\text{C}$

**Note 1:** For a surge greater than the maximum values, the diode will fail in short-circuit.

**Table 3: Thermal Resistances**

Symbol	Parameter	Value	Unit
$R_{th(j-l)}$	Junction to leads	20	$^{\circ}\text{C}/\text{W}$
$R_{th(j-a)}$	Junction to ambient on printed circuit. $L_{lead} = 10\text{mm}$	75	$^{\circ}\text{C}/\text{W}$

## P6KE

**Table 4: Electrical Characteristics** ( $T_{amb} = 25^{\circ}\text{C}$ )

Symbol	Parameter
$V_{RM}$	Stand-off voltage
$V_{BR}$	Breakdown voltage
$V_{CL}$	Clamping voltage
$I_{RM}$	Leakage current @ $V_{RM}$
$I_{PP}$	Peak pulse current
$\alpha T$	Voltage temperature coefficient
$V_F$	Forward voltage drop

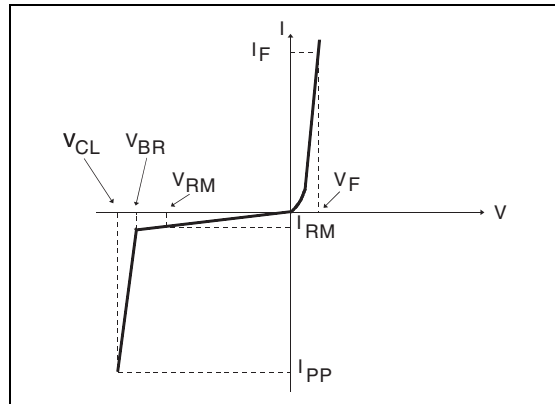

TYPES		$I_{RM} @ V_{RM}$		$V_{BR} @ I_R$				$V_{CL} @ I_{PP}$		$V_{CL} @ I_{PP}$		$\alpha T$	<b>C</b>
		max		min	nom	max		max		max		max	typ
Unidirectional	Bidirectional	$\mu\text{A}$	V	V	V	V	mA	V	A	V	A	$10^{-4}/^{\circ}\text{C}$	note4
P6KE6V8A	P6KE6.8CA	1000	5.8	6.45	6.8	7.14	10	10.5	57	13.4	298	5.7	4000
P6KE7V5A	P6KE7.5CA	500	6.4	7.13	7.5	7.88	10	11.3	53	14.5	276	6.1	3700
P6KE10A	P6KE10CA	10	8.55	9.5	10	10.5	1	14.5	41	18.6	215	7.5	2800
P6KE12A	P6KE12CA	5	10.2	11.4	12	12.6	1	16.7	36	21.7	184	7.8	2300
P6KE15A	P6KE15CA	1	12.8	14.3	15	15.8	1	21.2	28	27.2	147	8.4	1900
P6KE18A	P6KE18CA	1	15.3	17.1	18	18.9	1	25.2	24	32.5	123	8.8	1600
P6KE22A	P6KE22CA	1	18.8	20.9	22	23.1	1	30.6	20	39.3	102	9.2	1350
P6KE24A	P6KE24CA	1	20.5	22.8	24	25.2	1	33.2	18	42.8	93	9.4	1250
P6KE27A	P6KE27CA	1	23.1	25.7	27	28.4	1	37.5	16	48.3	83	9.6	1150
P6KE30A	P6KE30CA	1	25.6	28.5	30	31.5	1	41.5	14.5	53.5	75	9.7	1075
P6KE33A	P6KE33CA	1	28.2	31.4	33	34.7	1	45.7	13.1	59	68	9.8	1000
P6KE36A	P6KE36CA	1	30.8	34.2	36	37.8	1	49.9	12	64.3	62	9.9	950
P6KE39A	P6KE39CA	1	33.3	37.1	39	41.0	1	53.9	11.1	69.7	57	10.0	900
P6KE47A	P6KE47CA	1	40.2	44.7	47	49.4	1	64.8	9.3	84	48	10.1	800
P6KE56A	P6KE56CA	1	47.8	53.2	56	58.8	1	77	7.8	100	40	10.3	700
P6KE68A	P6KE68CA	1	58.1	64.6	68	71.4	1	92	6.5	121	33	10.4	625
P6KE82A	P6KE82CA	1	70.1	77.9	82	86.1	1	113	5.3	146	27	10.5	550
P6KE100A	P6KE100CA	1	85.5	95.0	100	105	1	137	4.4	178	22.5	10.6	500
P6KE120A	P6KE120CA	1	102	114	120	126	1	165	3.6	212	19	10.7	450
P6KE150A	P6KE150CA	1	128	143	150	158	1	207	2.9	265	15	10.8	400
P6KE180A	P6KE180CA	1	154	171	180	189	1	246	2.4	317	12.6	10.8	360
P6KE200A	P6KE200CA	1	171	190	200	210	1	274	2.2	353	11.3	10.8	350
P6KE220A	P6KE220CA	1	188	209	220	231	1	328	1.85	388	10.3	10.8	330
P6KE250A	P6KE250CA	1	213	237	250	263	1	344	1.75	442	9	11	310
P6KE300A	P6KE300CA	1	256	285	300	315	1	414	1.45	529	7.6	11	290
P6KE350A	P6KE350CA	1	299	332	350	368	1	482	1.25	618	6.5	11	270
P6KE400A	P6KE400CA	1	342	380	400	420	1	548	1.1	706	5.7	11	360
P6KE440A	P6KE440CA	1	376	418	440	462	1	603	1.0	776	5.2	11	350

Note 2: Pulse test :  $t_p < 50$  ms.

Note 3:  $\Delta V_{BR} = \alpha T \cdot (T_a - 25) \cdot V_{BR}(25^{\circ}\text{C})$ .

Note 4:  $V_R = 0$  V,  $F = 1$  MHz. For bidirectional types, capacitance value is divided by 2.

Figure 1: Pulse waveform (10/1000µs)

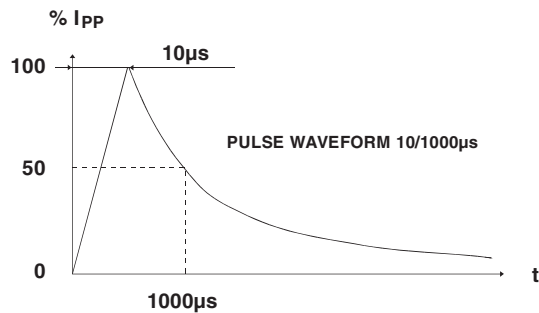

Figure 2: Peak power dissipation versus initial junction temperature (printed circuit board)

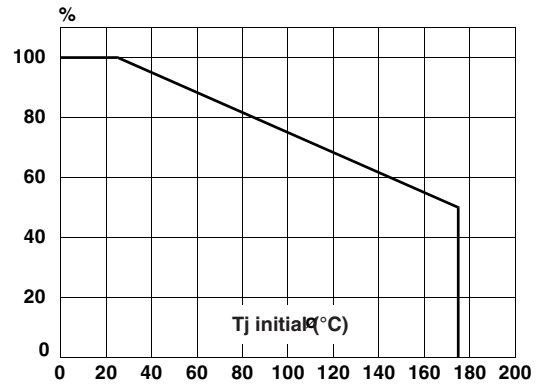

Figure 3: Peak pulse power versus exponential pulse duration

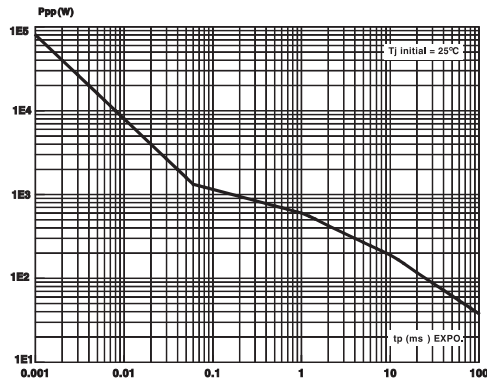
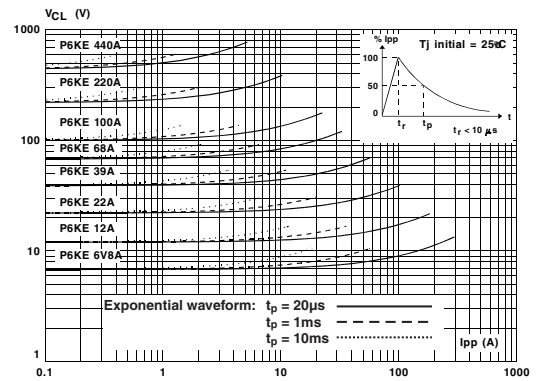

Figure 4: Clamping voltage versus peak pulse current (note 5)



**Note 5:** The curves of the figure 4 are specified for a junction temperature of 25°C before surge. The given results may be extrapolated for other junction temperatures by using the following formula :  $\Delta V_{BR} = \alpha T * [T_{amb} - 25] * V_{BR}(25^\circ C)$   
 For intermediate voltages, extrapolate the given results.

Figure 5: Capacitance versus reverse applied voltage for unidirectional types (typical values)

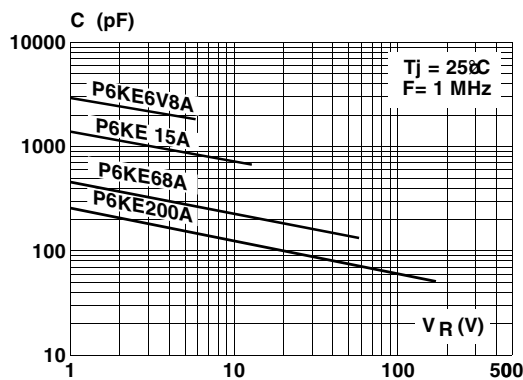
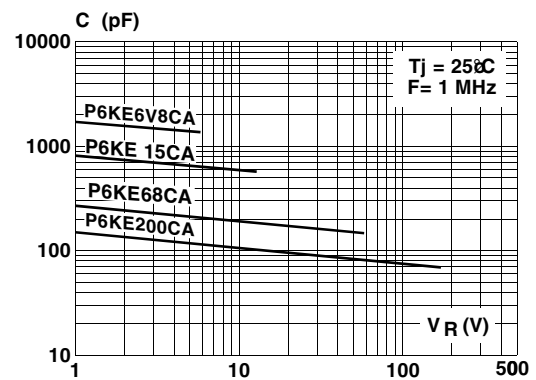
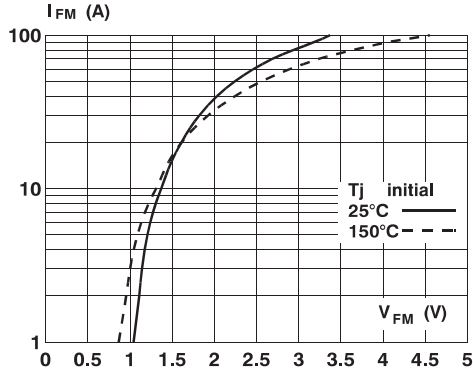

Figure 6: Capacitance versus reverse applied voltage for bidirectional types (typical values)

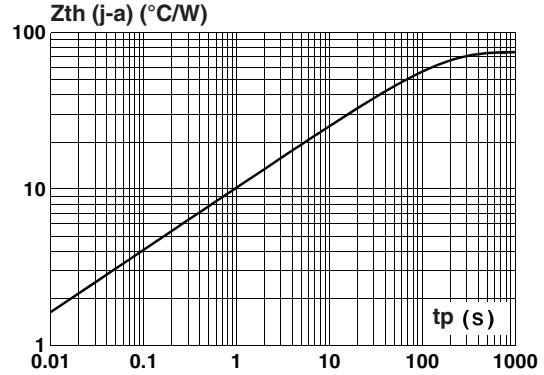

**Figure 7: Peak forward voltage drop versus peak forward current for unidirectional types (typical values)**

**Note:** multiply by 2 for units with  $V_{BR} \geq 200V$



**Figure 8: Transient thermal impedance junction to ambient versus pulse duration (for FR4 PC Board with  $L_{lead} = 10mm$ )**



**Figure 9: Relative variation of leakage current versus junction temperature**

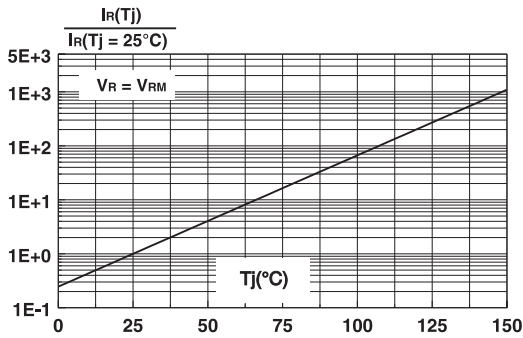

**Figure 10: Ordering Information Scheme**

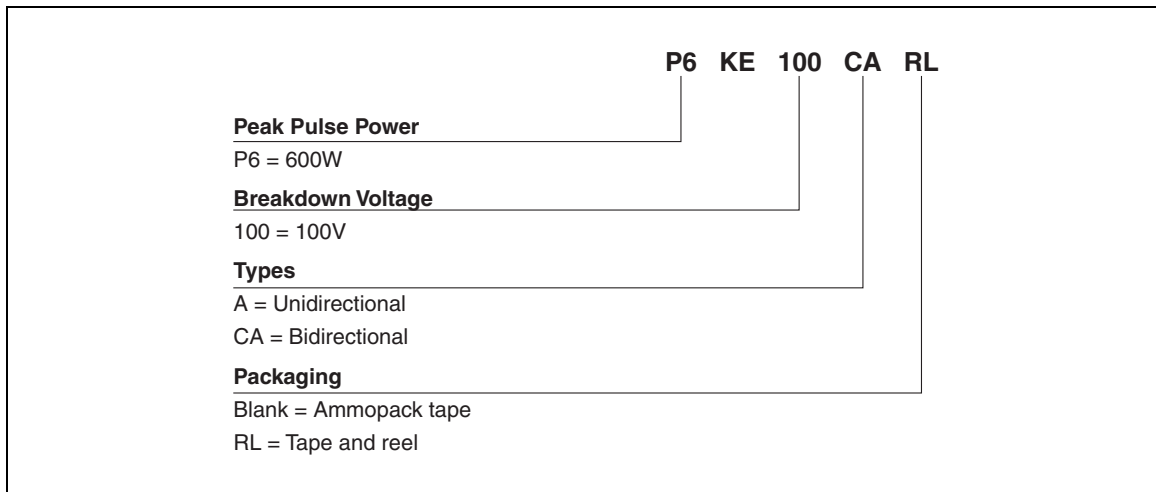

Figure 11: DO-15 (DO-204AC) Package Mechanical Data

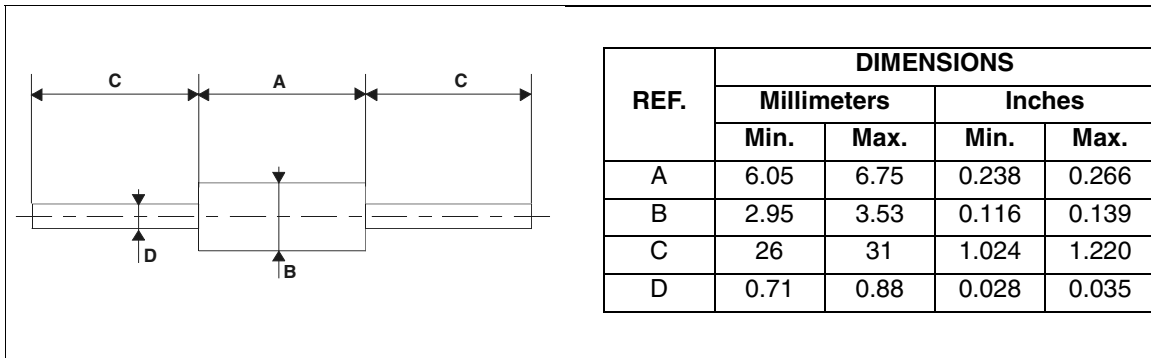

Table 5: Ordering Information

Part Number	Marking	Package	Weight	Base qty	Delivery mode
P6KExxx	See page 2	DO-15	0.4 g	1000	Ammopack
P6KExxxRL				6000	Tape & reel

Marking: Logo, data code, type code, cathode band (for unidirectional types only)

Table 6: Revision History

Date	Revision	Description of Changes
Feb-2003	4B	Last update.
Oct-2004	5	1/ Note 5, figure 7 on page 4, updated from $V_{BR} > 220V$ to $V_{BR} \geq 200V$ . 2/ Types table on page 2: $I_{PP}$ (@ 10/1000 $\mu$ s) changed for P6KE220xx to P6KE440xx

Information furnished is believed to be accurate and reliable. However, STMicroelectronics assumes no responsibility for the consequences of use of such information nor for any infringement of patents or other rights of third parties which may result from its use. No license is granted by implication or otherwise under any patent or patent rights of STMicroelectronics. Specifications mentioned in this publication are subject to change without notice. This publication supersedes and replaces all information previously supplied. STMicroelectronics products are not authorized for use as critical components in life support devices or systems without express written approval of STMicroelectronics.

The ST logo is a registered trademark of STMicroelectronics.  
All other names are the property of their respective owners

© 2004 STMicroelectronics - All rights reserved

**STMicroelectronics group of companies**

Australia - Belgium - Brazil - Canada - China - Czech Republic - Finland - France - Germany - Hong Kong - India - Israel - Italy - Japan -  
Malaysia - Malta - Morocco - Singapore - Spain - Sweden - Switzerland - United Kingdom - United States of America  
[www.st.com](http://www.st.com)