



## Features

- 72 V rated
- Radial leaded devices
- Cured, flame retardant epoxy polymer insulating material meets UL 94V-0 requirements
- RoHS compliant\*
- Agency recognition:

## Applications

Almost anywhere there is a low voltage power supply, up to 72 V and a load to be protected, including:

- Security and fire alarm systems
- Loudspeakers
- Power transformers

# MF-RX/72 Series - PTC Resettable Fuses

### Electrical Characteristics

Model	V max. Volts	I max. Amps	I <sub>hold</sub>	I <sub>trip</sub>	Initial Resistance		1 Hour (R <sub>1</sub> ) Post-Trip Resistance	Max. Time To Trip		Tripped Power Dissipation
			Amperes at 23 °C		Ohms at 23 °C		Ohms at 23 °C	Amperes at 23 °C	Seconds at 23 °C	Watts at 23 °C
			Hold	Trip	Min.	Max.	Max.			Typ.
MF-RX020/72	72	40	0.20	0.40	1.50	2.84	4.40	1.0	2.2	0.40
MF-RX025/72	72	40	0.25	0.50	1.00	1.95	3.00	1.25	2.5	0.45
MF-RX030/72	72	40	0.30	0.60	0.76	1.36	2.10	1.5	3.0	0.50
MF-RX040/72	72	40	0.40	0.80	0.52	0.86	1.29	2.0	3.9	0.55
MF-RX050/72	72	40	0.50	1.00	0.41	0.77	1.17	2.5	4.0	0.75
MF-RX065/72	72	40	0.65	1.30	0.27	0.48	0.72	3.25	5.3	0.90
MF-RX075/72	72	40	0.75	1.50	0.18	0.40	0.60	3.75	6.3	0.90
MF-RX090/72	72	40	0.90	1.80	0.14	0.31	0.47	4.5	7.2	1.00
MF-RX110/72	72	40	1.10	2.20	0.15	0.25	0.38	5.5	8.2	1.50
MF-RX135/72	72	40	1.35	2.70	0.12	0.19	0.30	6.75	9.6	1.70
MF-RX160/72	72	40	1.60	3.20	0.09	0.14	0.22	8.0	11.4	1.90
MF-RX185/72	72	40	1.85	3.70	0.08	0.12	0.19	9.25	12.6	2.10
MF-RX250/72	72	40	2.50	5.00	0.05	0.08	0.13	12.5	15.6	2.50
MF-RX300/72	72	40	3.00	6.00	0.04	0.06	0.10	15.0	19.8	2.80
MF-RX375/72	72	40	3.75	7.50	0.03	0.05	0.08	18.75	24.0	3.20

### Environmental Characteristics

Operating/Storage Temperature	-40 °C to +85 °C
Maximum Device Surface Temperature	
in Tripped State	125 °C
Passive Aging	+85 °C, 1000 hours .....±5 % typical resistance change
Humidity Aging	+85 °C, 85 % R.H. 1000 hours .....±5 % typical resistance change
Thermal Shock	+85 °C to -55 °C, 10 times .....±10 % typical resistance change
Solvent Resistance	MIL-STD-202, Method 215 .....No change
Vibration	MIL-STD-883C, Method 2007.1, .....No change Condition A

### Test Procedures And Requirements For Model MF-RX/72 Series

Test	Test Conditions	Accept/Reject Criteria
Visual/Mech.	Verify dimensions and materials	Per MF physical description
Resistance	In still air @ 23 °C	R <sub>min</sub> ≤ R ≤ R <sub>max</sub>
Time to Trip	5 times I <sub>hold</sub> , V <sub>max</sub> , 23 °C	T ≤ max. time to trip (seconds)
Hold Current	30 min. at I <sub>hold</sub>	No trip
Trip Cycle Life	V <sub>max</sub> , I <sub>max</sub> , 100 cycles	No arcing or burning
Trip Endurance	V <sub>max</sub> , 48 hours	No arcing or burning
UL File Number	E 174545S	

\*RoHS Directive 2002/95/EC Jan 27 2003 including Annex  
 Specifications are subject to change without notice.  
 Customers should verify actual device performance in their specific applications.

## Additional Features

- Resettable circuit protection
- Bulk packaging, tape and reel and Ammo-Pak available on most models

# MF-RX/72 Series - PTC Resettable Fuses

**BOURNS®**

### Product Dimensions

Model	A		B		C		D		E		Physical Characteristics		
	Max.		Max.		Nom.	Tol. ±	Min.		Max.		Style	Lead Dia.	Material
MF-RX020/72	7.4 0.291		12.7 0.5		5.1 0.201	0.7 0.028	7.6 0.299		3.1 0.122		1	0.51 0.020	Sn/CuFe
MF-RX025/72	7.4 0.291		12.7 0.5		5.1 0.201	0.7 0.028	7.6 0.299		3.1 0.122		1	0.51 0.020	Sn/CuFe
MF-RX030/72	7.4 0.291		13.4 0.528		5.1 0.201	0.7 0.028	7.6 0.299		3.1 0.122		1	0.51 0.020	Sn/CuFe
MF-RX040/72	7.40 0.291		13.7 0.539		5.1 0.201	0.7 0.028	7.6 0.299		3.1 0.122		1	0.51 0.020	Sn/CuFe
MF-RX050/72	7.9 0.311		13.7 0.539		5.1 0.201	0.7 0.028	7.6 0.299		3.1 0.122		1	0.51 0.020	Sn/Cu
MF-RX065/72	9.7 0.382		15.2 0.598		5.1 0.201	0.7 0.028	7.6 0.299		3.1 0.122		1	0.51 0.020	Sn/Cu
MF-RX075/72	10.4 0.409		16.0 0.630		5.1 0.201	0.7 0.028	7.6 0.299		3.1 0.122		1	0.51 0.020	Sn/Cu
MF-RX090/72	11.7 0.461		16.70 0.657		5.1 0.201	0.7 0.028	7.6 0.299		3.1 0.122		1	0.51 0.020	Sn/Cu
MF-RX110/72	10.84 (0.427)		16.84 (0.662)		5.1 (0.201)	0.7 (0.028)	7.6 (0.299)		3.1 (0.122)		2	0.81 (0.032)	Sn/Cu
MF-RX135/72	12.26 (0.483)		18.26 (0.718)		5.1 (0.201)	0.7 (0.028)	7.6 (0.299)		3.1 (0.122)		2	0.81 (0.032)	Sn/Cu
MF-RX160/72	13.94 (0.549)		19.94 (0.785)		5.1 (0.201)	0.7 (0.028)	7.6 (0.299)		3.1 (0.122)		2	0.81 (0.032)	Sn/Cu
MF-RX185/72	15.18 (0.598)		21.18 (0.833)		5.1 (0.201)	0.7 (0.028)	7.6 (0.299)		3.1 (0.122)		2	0.81 (0.032)	Sn/Cu
MF-RX250/72	17.84 (0.702)		23.84 (0.938)		10.2 (0.402)	0.7 (0.028)	7.6 (0.299)		3.1 (0.122)		2	0.81 (0.032)	Sn/Cu
MF-RX300/72	20.67 (0.814)		26.67 (1.050)		10.2 (0.402)	0.7 (0.028)	7.6 (0.299)		3.1 (0.122)		2	0.81 (0.032)	Sn/Cu
MF-RX375/72	23.51 (0.926)		29.51 (1.161)		10.2 (0.402)	0.7 (0.028)	7.6 (0.299)		3.1 (0.122)		2	0.81 (0.032)	Sn/Cu

Packaging options:

BULK: 500 pcs. per bag.

TAPE & REEL: MF-RX020/72-2 ~ MF-RX090/72-2 = 3000 pcs. per reel; MF-RX110/72-2 ~ MF-RX160/72-2 = 1500 pcs. per reel; MF-RX185/72-2 - MF-RX375/72-2 = 1000 pcs. per reel.

AMMO-PACK: MF-RX020/72-AP ~ MF-RX090/72-AP = 2000 pcs. per pack; MF-RX110/72-AP ~ MF-RX160/72-AP = 1000 pcs. per pack; MF-RX185/72-AP - MF-RX375/72-AP = 500 pcs. per pack.

DIMENSIONS =  $\frac{\text{MM}}{\text{(INCHES)}}$

Style 1

Style 2

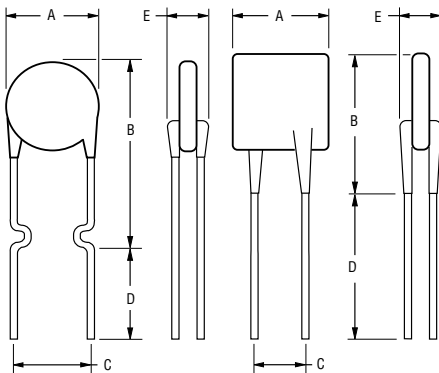

### Typical Part Marking

Represents total content. Layout may vary.

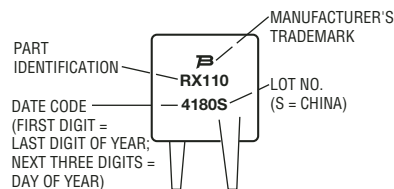

### How to Order

**MF - RX 110/72 - 2**

Multifuse®  
Product Designator

Series  
RX = Radial Leaded Component

Hold Current,  $I_{hold}$   
020-375 (0.20 Amps - 3.75 Amps)

Maximum Voltage,  $V_{max}$   
72 (72 Volts)

Packaging Options  
- 0 = Bulk Packaging  
- 2 = Tape and Reel\*  
- AP = Ammo-Pak\*

\*Packaged per EIA 486-B

Specifications are subject to change without notice.  
Customers should verify actual device performance in their specific applications.

# MF-RX/72 Series - PTC Resettable Fuses

**BOURNS®**

## Typical Time to Trip at 23 °C

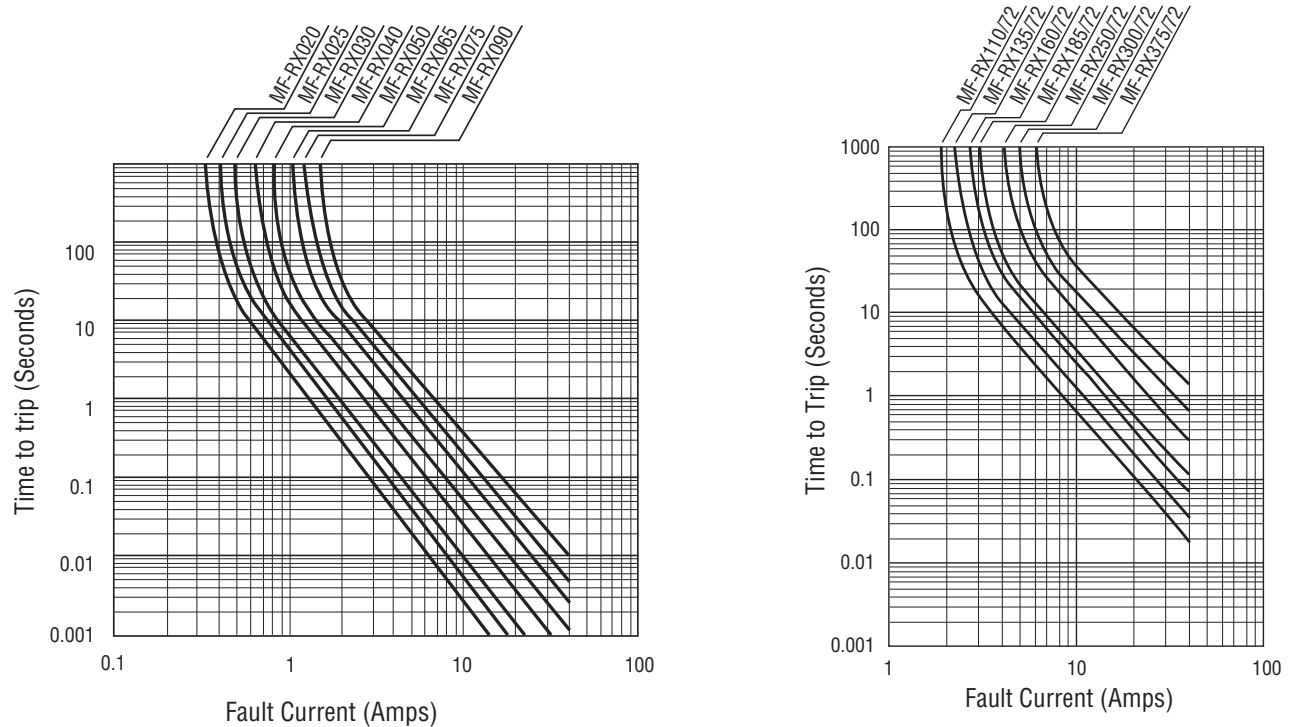

The Time to Trip curves represent typical performance of a device in a simulated application environment. Actual performance in specific customer applications may differ from these values due to the influence of other variables.

## Thermal Derating Chart - $I_{hold}$ (Amps)

Model	Ambient Operating Temperature								
	-40 °C	-20 °C	0 °C	23 °C	40 °C	50 °C	60 °C	70 °C	85 °C
MF-RX020/72	0.31	0.27	0.24	0.20	0.16	0.14	0.13	0.11	0.08
MF-RX025/72	0.39	0.34	0.30	0.25	0.20	0.18	0.16	0.14	0.10
MF-RX030/72	0.47	0.41	0.36	0.30	0.24	0.22	0.19	0.16	0.12
MF-RX040/72	0.62	0.54	0.48	0.40	0.32	0.29	0.25	0.22	0.16
MF-RX050/72	0.78	0.68	0.60	0.50	0.41	0.36	0.32	0.27	0.20
MF-RX065/72	1.01	0.88	0.77	0.65	0.53	0.47	0.41	0.35	0.26
MF-RX075/72	1.16	1.02	0.89	0.75	0.61	0.54	0.47	0.41	0.30
MF-RX090/72	1.40	1.22	1.07	0.90	0.73	0.65	0.57	0.49	0.36
MF-RX110/72	1.71	1.50	1.31	1.10	0.89	0.79	0.69	0.59	0.44
MF-RX135/72	2.09	1.84	1.61	1.35	1.09	0.97	0.85	0.73	0.54
MF-RX160/72	2.48	2.18	1.90	1.60	1.30	1.15	1.01	0.86	0.64
MF-RX185/72	2.87	2.52	2.20	1.85	1.50	1.33	1.17	1.00	0.74
MF-RX250/72	3.88	3.40	2.98	2.50	2.03	1.80	1.58	1.35	1.00
MF-RX300/72	4.65	4.08	3.57	3.00	2.43	2.16	1.89	1.62	1.20
MF-RX375/72	5.81	5.10	4.46	3.75	3.04	2.70	2.36	2.03	1.50

MF-RX/72 SERIES, REV. E, 02/08

Specifications are subject to change without notice. Customers should verify actual device performance in their specific applications.

**MF-R, MF-R/90, MF-R/600, MF-RX, MF-RX/72 & MF-RX/250 Series  
Tape and Reel Specifications**

**BOURNS®**

Devices taped using EIA468-B/IEC286-2 standards. See table below and Figures 1 and 2 for details.

Dimension Description	IEC Mark	EIA Mark	Dimensions	
			Dimensions	Tolerance
Carrier tape width	$W$	$W$	$\frac{18}{(.709)}$	$\frac{-0.5/+1.0}{(-0.02/+0.039)}$
Hold down tape width:	$W_0$	$W_4$	$\frac{11}{(.433)}$	min.
Hold down tape			No protrusion	
Top distance between tape edges	$W_2$	$W_6$	$\frac{3}{(.118)}$	max.
Sprocket hole position	$W_1$	$W_5$	$\frac{9}{(.354)}$	$\frac{-0.5/+0.75}{(-0.02/+0.03)}$
Sprocket hole diameter	$D_0$	$D_0$	$\frac{4}{(.157)}$	$\frac{\pm 0.2}{(\pm .0078)}$
Abscissa to plane (straight lead)	$H$	$H$	$\frac{18.5}{(.728)}$	$\frac{\pm 3.0}{(\pm .118)}$
Abscissa to plane (kinked lead)	$H_0$	$H_0$	$\frac{16}{(.63)}$	$\frac{\pm 0.5}{(\pm .02)}$
Abscissa to top (straight lead)	$H_1$	$H_1$	$\frac{38.0}{(1.496)}$	max.
Abscissa to top (kinked lead)	$H_1$	$H_1$	$\frac{32.2}{(1.268)}$	max.
Overall width w/lead protrusion (straight lead)		$C_1$	$\frac{55.0}{(2.165)}$	max.
Overall width w/lead protrusion (kinked lead)		$C_1$	$\frac{43.2}{(1.7)}$	max.
Overall width w/o lead protrusion (straight lead)		$C_2$	$\frac{54.0}{(2.126)}$	max.
Overall width w/o lead protrusion (kinked lead)		$C_2$	$\frac{42.5}{(1.673)}$	max.
Lead protrusion	$I_1$	$L_1$	$\frac{1.0}{(.039)}$	max.
Protrusion of cutout	$L$	$L$	$\frac{11}{(.433)}$	max.
Protrusion beyond hold tape	$I_2$	$I_2$	Not specified	
Sprocket hole pitch	$P_0$	$P_0$	$\frac{12.7}{(0.5)}$	$\frac{\pm 0.3}{(\pm .012)}$
Pitch tolerance			20 consecutive	$\frac{\pm 1}{(\pm .039)}$
Device pitch: MF-R005-MF-R160, MF-R/90, MF-RX110/72-MF-RX185/72			$\frac{12.7}{(0.5)}$	$\frac{\pm 0.3}{(\pm .012)}$
Device pitch: MF-R185-MF-R400, MF-RX110-MF-RX375 MF-R/600, MF-RX250/72-MF-RX375/72			$\frac{25.4}{(1.0)}$	$\frac{\pm 0.6}{(\pm .024)}$
Tape thickness	$t$	$t$	$\frac{0.9}{(.035)}$	max.
Tape thickness with splice: MF-R010-MF-R160, MF-RX110/72-MF-RX185/72,		$t_1$	$\frac{1.5}{(.059)}$	max.
Tape thickness with splice: MF-R250-MF-R1100 MF-RX110-MF-RX375, MF-R/90, MF-RX250/72-MF-RX375/72		$t_1$	$\frac{2.3}{(.091)}$	max.
Splice sprocket hole alignment			0	$\frac{\pm 0.3}{(\pm .012)}$ $\frac{\pm 1.0}{(\pm .039)}$
Body lateral deviation	$\Delta h$	$\Delta h$	0	$\frac{\pm 1.3}{(\pm .051)}$
Body tape plane deviation	$\Delta p$	$\Delta p$	0	$\frac{\pm 0.2}{(\pm .008)}$
Lead spacing	$F$	$F$	$\frac{5.08}{(0.2)}$	$\frac{\pm 0.2}{(\pm .008)}$
Reel width	$w$	$W_2$	$\frac{56}{(2.205)}$	max.
Reel diameter	$d$	$a$	$\frac{370}{(14.57)}$	max.
Space between flanges less device	$W_1$	$h$	$\frac{4.75}{(.187)}$	$\frac{\pm 3.25}{(\pm .128)}$

Specifications are subject to change without notice.

Customers should verify actual device performance in their specific applications.

DIMENSIONS =  $\frac{\text{MM}}{\text{(INCHES)}}$

**MF-R, MF-R/90, MF-R/600, MF-RX, MF-RX/72 & MF-RX/250 Series  
Tape and Reel Specifications**

**BOURNS®**

Dimension Description	IEC Mark	EIA Mark	Dimensions	
			Dimensions	Tolerance
Arbor hole diameter	<i>f</i>	<i>c</i>	$\frac{26}{(1.024)}$	$\frac{\pm 12.0}{(\pm .472)}$
Core diameter: MF-R, MF-RX, MF-R/90	<i>h</i>	<i>n</i>	$\frac{80}{(3.15)}$	max.
Core diameter: MF-RX/250, MF-R/600	<i>h</i>	<i>n</i>	$\frac{91}{(3.58)}$	max.
Box: MF-R, MF-RX, MF-R/90			$\frac{56}{(2.2)}$ $\frac{372}{(14.6)}$ $\frac{372}{(14.6)}$	max.
Box: MF-RX/250			$\frac{67}{(2.64)}$ $\frac{372}{(14.6)}$ $\frac{362}{(14.25)}$	max.
Box: MF-R/600			$\frac{64}{(2.52)}$ $\frac{372}{(14.6)}$ $\frac{362}{(14.25)}$	max.
Consecutive missing places: MF-R, MF-RX, MF-R/90			3	max.
Consecutive missing places: MF-RX/250, MF-R/600			none	
Empty places per reel: MF-R, MF-RX, MF-R/90			Not specified	
Empty places per reel: MF-RX/250, MF-R/600			0.1 %	

**Taped Component Dimensions - Figure 1**

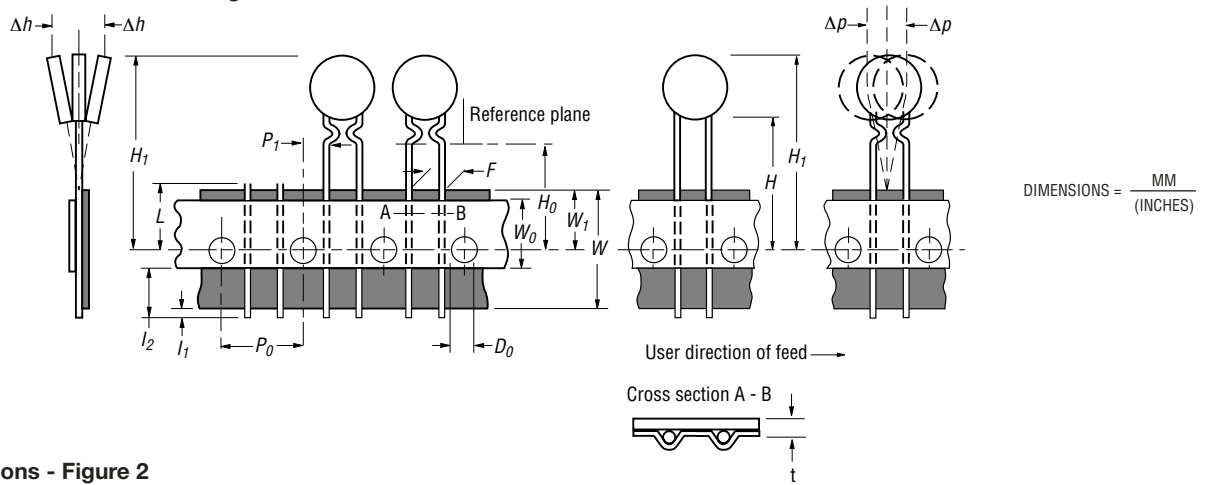

**Reel Dimensions - Figure 2**

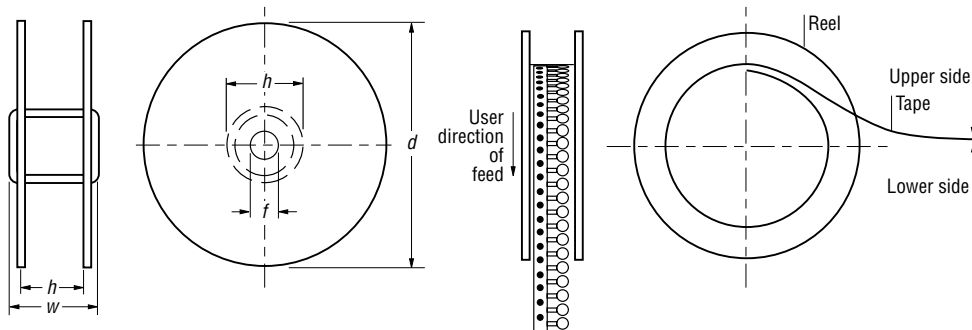

Specifications are subject to change without notice.  
Customers should verify actual device performance in their specific applications.