

FK1 MINI® Style Blade Fuse Rated 32V



Specifications

DIN 72581/3F
 ISO 8820
 UL 248 Special Purpose Fuses

cULus Recognized: File No. E211637

Insulating body: Out of thermoplastic (UL 94-V0, heat-resistant)

Cover: Out of thermoplastic (V0, transparent)
 Visible melting-element
 Red, not transparent

Connections: Blade contacts
 Copper alloy, gal. Sn
 Edge-protected

Breaking capacity: 1,000 A, 32 V, DC

The FK1 32V automotive standard fuse link in a MINI® package. Three part construction with copper contacts for excellent reliability in harsh environment conditions with low voltage drop. Current ratings 1A thru 30A. See-through cover for easy detection of blown fuses.

Die FK1 32V-Standardsicherung im MINI®-Gehäuse. Dreiteiliger Aufbau mit Kupferkontakten, niedriger Spannungsabfall und hohe Zuverlässigkeit unter rauen Umgebungsbedingungen. Nennstrom 1A bis 30A, transparente Abdeckung zur leichten Erkennung durchgebrannter Sicherungen.

Time-Current Characteristics / Schmelzeit-Grenzwerte

% of Rating % des Nennstromes	Opening Time Min / Max (s) Schmelzcharakteristik Min / Max (s)
110	100 h / –
135	750 ms / 1,800 s
200	150 ms / 5 s
350	40 ms / 500 ms
600	20 ms / 100 ms

Part Number Artikel-Nr.	Current Rating Nennstrom	Housing Color Kennfarbe	Typ. Voltage Drop Typ. Spannungsfall		Cold Resistance Kaltwiderstand	I ² t
			Standard DIN max.	Littelfuse max.		
168.6785.410_	1 A	Black	225 mV	135 mV	100 mΩ	0.83 A²s
168.6785.420_	2 A	Grey	200 mV	110 mV	43.0 mΩ	3.31 A²s
168.6785.430_	3 A	Purple	175 mV	110 mV	27.0 mΩ	7.45 A²s
168.6785.440_	4 A	Pink	175 mV	110 mV	21.3 mΩ	16.7 A²s
168.6785.450_	5 A	Brown	175 mV	105 mV	16.2 mΩ	19.8 A²s
168.6785.475_	7.5 A	Dark Brown	150 mV	100 mV	9.70 mΩ	44.5 A²s
168.6785.510_	10 A	Red	125 mV	110 mV	7.40 mΩ	79.2 A²s
168.6785.515_	15 A	Blue	125 mV	105 mV	4.50 mΩ	178 A²s
168.6785.520_	20* A	Yellow	–	100 mV	3.10 mΩ	331 A²s
168.6785.525_	25* A	White	–	120 mV	2.60 mΩ	653 A²s
168.6785.530_	30* A	Green	–	105 mV	1.95 mΩ	1,264 A²s
160.6785.000_	Shunt* A	White	–	60 mV	1.35 mΩ	1,800 A²s

* Not mentioned in the standards
 Last figure of part number = packaging code, see Section "Packaging Index," pg. 157.
 Corresponding holder see Section "Fuse Holders."

FK1 MINI® Style Blade Fuse Rated 32V

Dimensions in mm / Maße in mm

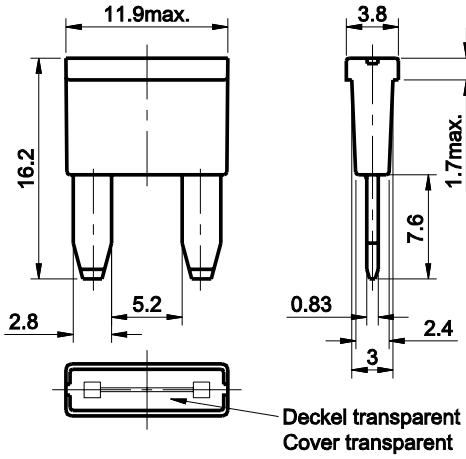

Pre-arcing Time - limits / Schmelzeit-Grenzwerte DIN

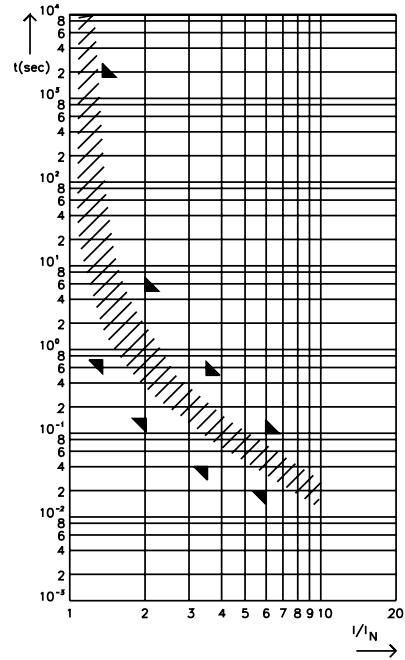

FI = 1.33 (max. operating current: $0.75 \times I_{rat}$ at 23°C)

Blade Fuses