

Bussmann

HRC FUSE HOLDERS

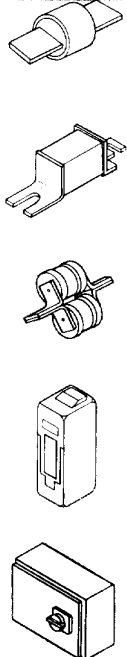

COOPER
Bussmann

CAMASTER HRC FUSE HOLDERS

DESCRIPTION

A range of fully shrouded HRC Fuse Holders designed to accommodate offset bolted tag H.R.C. fuse links to BS88: Parts 1 & 2, 1988 (IEC 269-1 & 2: 1986).

The compact dimensioned 32A Fuse Holder, type CM32FC accepts the A1 size fuse link NITD2-32A and the standard 32A, type CM32F accepts the A2 size fuse link AAO2-32A.

The 63A unit, type CM63F accepts the A3 size fuse link BAO40-63 and the 100A units, type CM100F accept the compact A3 fixing centres, fuse link type OSD80-100A.

The Fuse Holders are supplied standard as Front Connection and can readily be converted to Front/Back Stud or Double Back Stud Connection types at the point of use using the appropriate size Back Stud Accessories.

FEATURES

The Fuse Holders have an advanced patented design incorporating a high level of innovation, with enhanced performance characteristics and fully comply with the requirements of BS88: 1988 (IEC269:1986) and the 16th edition of the IEE Wiring Regulations.(BS7671)

The Fuse Carriers are fitted with a Cam for ease of removal from the Fuse Bases allowing significantly improved contact pressure between Fuse Carrier contacts and Base contacts, with a corresponding enhanced electrical performance level. This design overcomes a major problem of all existing British Standard style Fuse Holders manufactured world - wide, which have to compromise between difficulties of Fuse Carrier removal from Base and contact pressure achieved.

CAMASTER Fuse Holders feature a unique channel-and-guide arrangement which prevents any tilting of the Fuse Carrier when it is being inserted or removed and so eliminates any

likelihood of inadvertent contact with live metal.

HINGED CAPTIVE SCREWS

The fuse link fixing screws to the Fuse Carrier are held in captive hinges providing ease of fixing and preventing loss during installation.

The hinges also act as pressure plates thereby reducing the contact resistance between fuse link tags and the Carrier Contact.

UNIQUE CABLE TERMINATION

The Fuse Holders unique cable terminations fully meet the requirements of Sub-Clause 7.1.7 - Terminals of IEC.947: Part 1: 1989 Low Voltage Switchgear and Controlgear.

They incorporate Stainless Steel Saddles and Hardened Termination Screws, maintaining permanent cable clamping to profiled contact plates. The main electrical contact path between the cable and fuse link tag is shown highlighted. This permits the use of high tightening torques without damage to cables or threads and provides resistance to high cable pull out forces.

The Fuse Holders are supplied with the Hardened Termination Screws backed out ready for cable insertion, saving installation time.

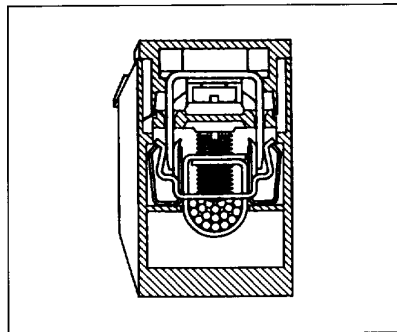

A range of Lockable Safety Carriers for the CAMASTER Fuse Holder (Cat ref:

LSC), are available. This distinct feature ensures isolation can be achieved allowing maintenance to be carried out in safety.

DUAL MOUNTING CAPABILITY

The design as standard provides both Bolted Panel and DIN Rail mounting features. The DIN Rail mounting facility for each of the various dimensioned ratings is so designed as to give equal height and depth above the DIN Rail.

HINGED INTERNAL SHIELDS

Non-removable full shrouding of live parts within the Fuse Base is provided by the use of hinged shields. The positive captive nature of these ensures that they cannot be omitted during installation and are so designed that insertion of the Fuse Carrier can only be made with them correctly positioned.

NEON INDICATOR

Neon clip-in indicator accessories are available. They provide clear location and status of outgoing circuits, the neon being lit when the fuse link has operated under fault conditions.

CIRCUIT IDENTIFICATION

The Fuse Carrier has a marking label for ease of circuit identification.

STRIP LENGTH MARKING

The length of cable insulation that should be stripped off is shown on the side of the Fuse Base.

TWO/THREE POLE GANGING

The unique design of the Carriers allows ganging to be readily achieved by the use of standard accessories. This provides improved safety related to isolation and protection of 2 Pole and 3 Pole electrical circuits by ensuring that the correctly related poles are removed at the same time.

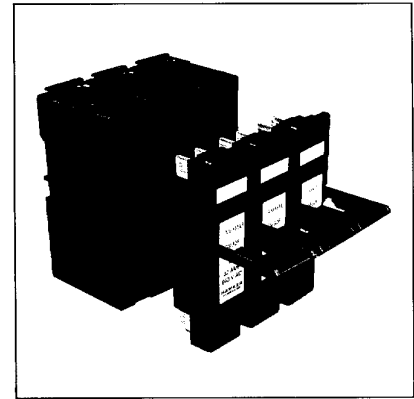
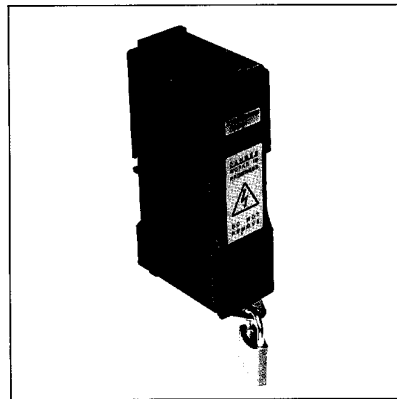
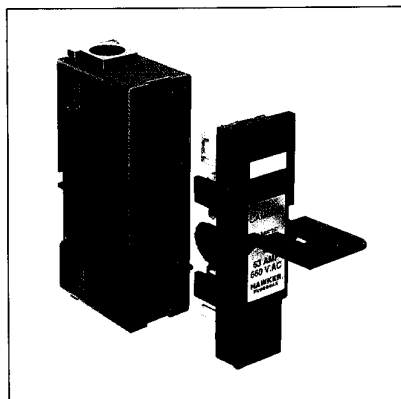

CAMASTER HRC FUSE HOLDERS

RATINGS, CATALOGUE NUMBERS AND DIMENSIONS

Standard Front Connected Unit

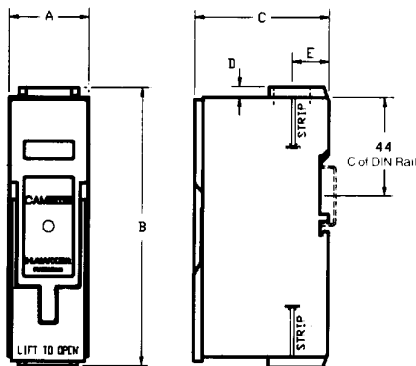

Suitable for either Bolted Panel or DIN Rail mounting.

Front/Back Stud and Double Back Stud Connected Units

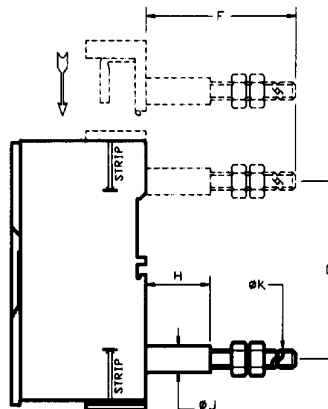

Units allow easy customer conversion to either Front/Back Stud or Double Back Stud Connected by use of Back Stud Accessory Packs. Using only a screwdriver.

Rating Amps	Cat. No.	Max. Cable mm ²	Use Fuse link Type	Dimensions in mm.						Dimensions in mm.				
				A	B	C	D	E	L(2)	F	G	H	J	K
32	CM32FC	16	NITD	25.4	93.7	60	3.2	17.5	44.4	66	58	28.6	11.9	M6
32	CM32F	16	AAO	31.8	117.5	60	3.2	17.5	58.5	66	74	28.6	11.9	M6
63	CM63F	70	BAO	35.6	125	60	4.75	16.4	55.0	86.5	79.8	28.6	11.9	M8
100	CM100F	70	OSD	35.6	125	60	4.75	16.4	55.0	86.5	79.8	28.6	11.9	M8

ACCESSORIES			
	RATING Amps	Cat. No.	Carton Qty
Back Stud	32	32BSC	10
	32	32BS	10
Ganging Links	63/100	63/100BS	5
		GLP	1 SET
Neon Indicator	90-660 VAC	NI	3
Lockable Safety Carriers	32LSCC	32LSC	3
	32LSC	32LSC	3
	63/100LSC	63/100LSC	3
Security Clip	CMSC	CMSC	20

Panel Drilling Plans. Viewed from front of Panel.

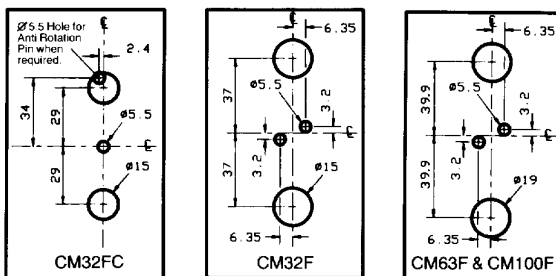

NOTES:

1. Type CM32FC is also available rated at 20A – catalogue number CM20F.
2. Units supplied as standard without the test probe holes. If these are required details are available on request.
3. For colours other than black (standard) add the appropriate letter code: White – W, Green – G, Grey – GY.

The conversion sequence is shown below:

UNIQUE CONVERSION CAPABILITY

The standard Fuse Holders can be readily converted from Front Connection to Front/Back Stud and Double Back Stud Connection types at the point of use. This is achieved with a unique Back Stud Accessory and the use of a screwdriver.

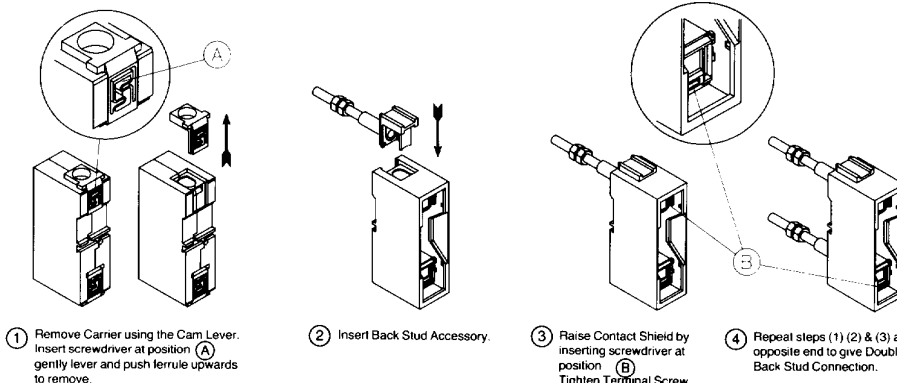

SAFELOC HRC FUSE HOLDERS

DESCRIPTION

The patented SAFELOC Fuse Holders provide a simple safe range designed to accommodate the compact range of offset blade tag fuse links to BS88:6:1988. The combination offers significant savings in volume and cost as well as a reduction in fitting time and power loss.

FEATURES

The Fuse Holders incorporate a unique slide/snap action Carrier which eliminates the need for fuse carrier contacts. This provides positive, stress free fitting of fuse links and locks the fuse link in position ensuring safe insertion and withdrawal from the base. The resulting direct contact between fuse link blades and the plated base contacts provides lower watts loss and increased reliability. The Base Contacts are fully shrouded to protect personnel from direct contact electric shock. The shrouds utilise simple slide/snap action allowing access to the contact terminal screws. They are semi-captive within the base, reducing the risk of loss during cabling. The Fuse Base, which consists of glass filled, high impact resistant thermoplastic polyester, incorporates a direct 35mm DIN rail mounting facility as well as single screw fixing. An anti-rotation pin is available if required.

BENEFITS

SAFELOC Fuse Holders have been designed for use with offset blade tag fuse links.

The NNS Fuse Holder accommodates the NSD range of compact H.R.C. fuse links whilst the slightly larger ENS Fuse

Holder accommodates the ESD range of Compact H.R.C. fuse links.

Both are available in Front Connection, or Back Stud arrangements or combinations of these.

The associated fuse link and service voltages are as follows:

	Fuse link ratings	
	NNS	ENS
SAFELOC type	NNS	ENS
Fuse link type	NSD	ESD
Service voltage		
550V	2-32A	2-32A
415V		40-63A

All of the compact range of fuse links have an excellent ability to protect induction motor circuits. The unique design of the SAFELOC Fuse Holders has enabled Hawker Fusegear to design an extended range of dual rated fuse links which offer protection for motor circuits up to 40 h.p. Fuse links in this extended range have ratings, as defined in BS88, a lower rating, which relates to its continuous current carrying capability, and a higher rating, which relates to its ability to withstand motor starting surges. For example, an ESD63M 100 has a continuous current carrying capability of 63A coupled with the time/current characteristic and thus the withstand capabilities of a 100A fuse link.

The correct application of these fuse links in motor circuits can achieve significant economies in the size and cost of installations.

The associated dual rated fuse links are shown in the table below.

SAFELOC type	Fuse link ratings	
	NNS	ENS
Fuse link type	NSD	ESD
Service voltage	20M25	63M80
415V	20M32	63M100
	20M36	
	32M36	
	32M40	
	32M50	
	32M63	

Notes:

1) Motor circuit protection fuse links should never be operated on continuous currents in excess of the lower of its current ratings.

2) When selecting from this range of fuse links ensure that the voltage rating is adequate.

SAFELOC Fuse Holders provide a safe and easy method of protecting a wide range of electrical equipment such as lighting, heating, motor and control equipment circuits, and offer significant savings on volume, cost, fitting time and power loss.

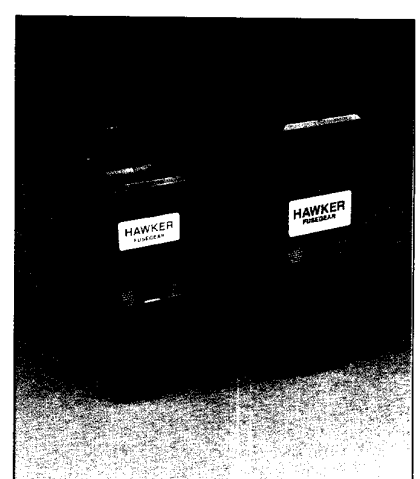
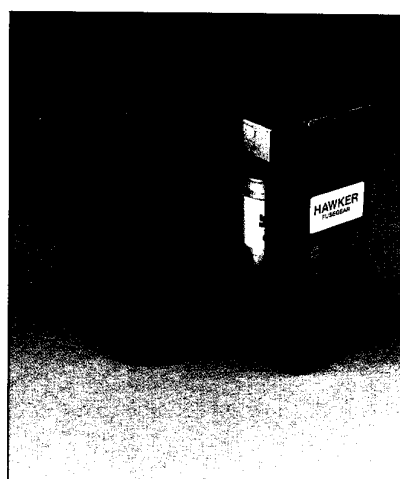
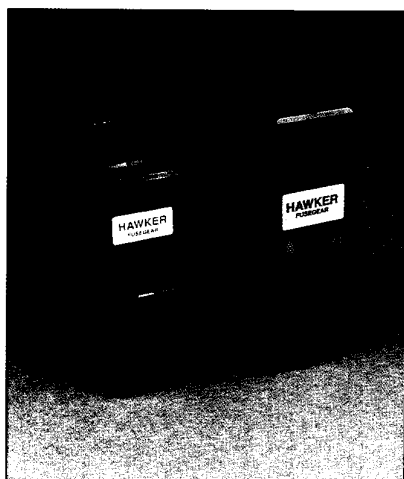

SAFELOC HRC FUSE HOLDERS

RATINGS, CATALOGUE NUMBERS AND DIMENSIONS

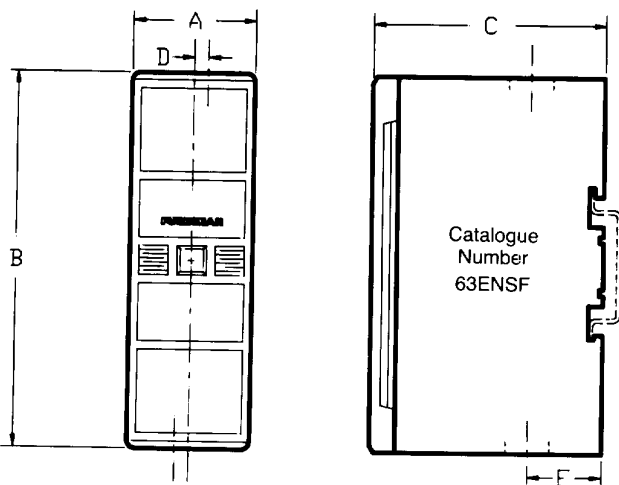
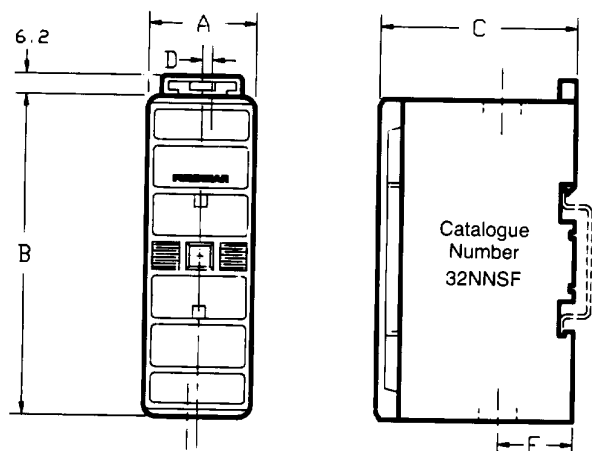

Available Variants	Catalogue	Numbers
	NNS	ENS
Front Connected/ Front Connected	32NNSF	63ENSF
Back Stud/Back Stud	32NNSBS	63ENSBS
Front Connected/Back Stud	32NNSFBS	63ENSFBS

Suitable for either Bolted Panel
or DIN Rail mounting.

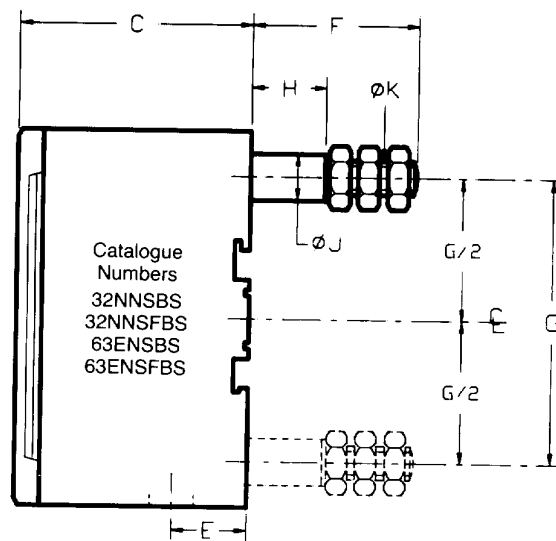

Rating Amps	Cat. No.	Max Cable mm ²	Use Fuselink Type	Dimensions in mm.									
				A	B	C	D	E	F	G	H	J	K
32	NNS	16	NSD	25.4	76.2	46.5	2.3	16	39.2	57.7	17	9.7	M6
63	ENS	35	ESD	29.1	90	55	3.3	17.7	75	67.9	39.2	11	M8

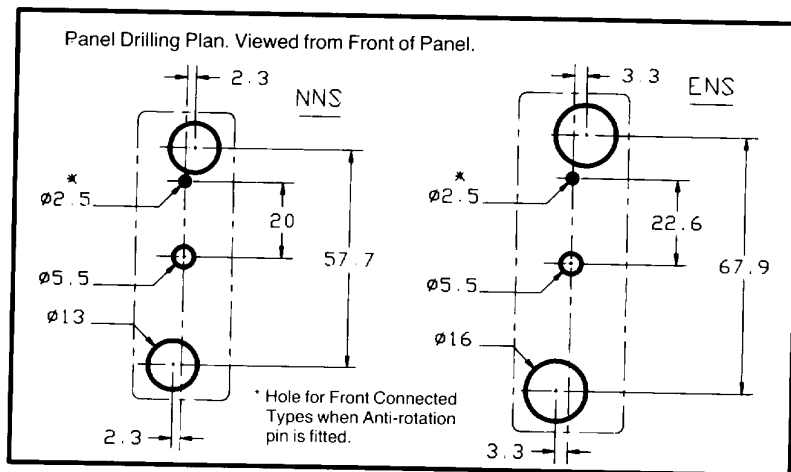

NOTE: FOR COLOURS OTHER THAN
BLACK (STANDARD) ADD THE
APPROPRIATE LETTER CODE:
WHITE - W, GREEN - G
GREY - GY.
eg. 32NNSFW.

Two ranges of Fuse Banks are available utilising the CAM^{MASTER} and SAFE^{LOC} H.R.C. Fuse Holders.

The Fuse Banks consist of single phase assemblies of busbar connected Fuse Holders, mounted on a black strap for incorporation into Distribution Fuse Boards.

Compatible ranges of Neutral Bars and Earth Terminal Bars are also available, together with enclosure door Circuit Identification Labels.

A range of Industrial Enclosures is available allowing Single Pole and Double Pole Distribution Fuse Boards to be readily assembled. Factory assembled Triple Pole and Neutral Boards are available to order.

Also available is the CAM^{LOC} Distribution Fuseboard System suitable for direct connection with a 200A maximum capability or fitted with an integral on-load isolator of either 63A or 125A rating.

The outgoing circuits are available in three distinct ratings which can be mixed on the Pan Assembly within the maximum capability of the incoming circuits.

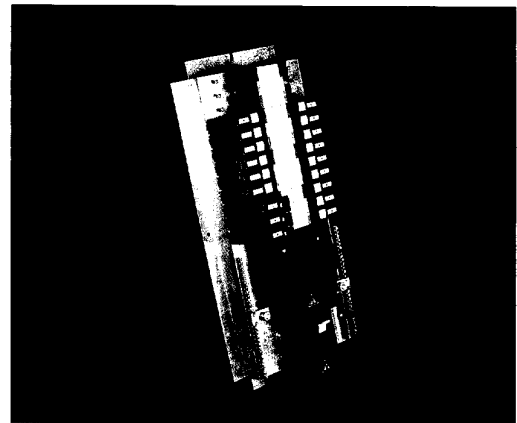
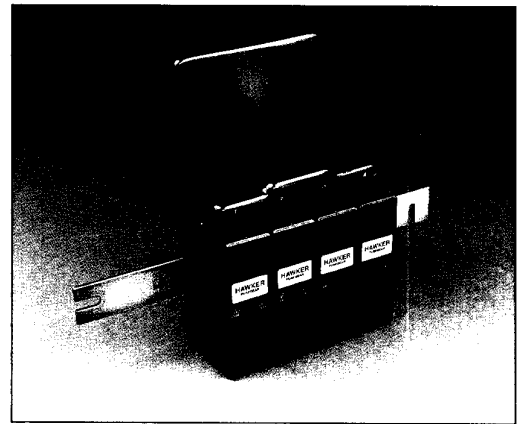
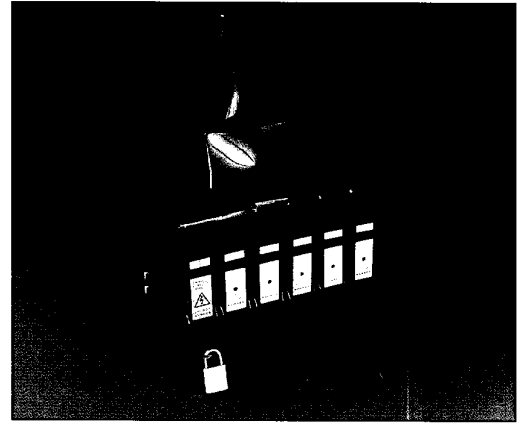

COOPER
Bussmann

Burton-on-the-Wolds, Leics, LE12 5TH. UK.
Tel: (0509) 880737. Telex: 341768 FUSES G.
Fax: (0509) 881309 (Group 3)



HEALTH & SAFETY AT WORK ACT 1974 (U.K.)

The products referred to in this catalogue are manufactured and tested to the specification indicated on the product referred to in this catalogue as applicable to the appropriate type reference number, but must be correctly installed by competent personnel to provide protection within the capability of the stated ratings and related performance characteristics.

The information contained in this catalogue is correct at the time of publication, but we reserve the right to supply products differing in construction or performance.