

Customer Information Sheet

DRAWING No.: D2899-XX

SHEET 2 OF 2

IF IN DOUBT - ASK

©

NOT TO SCALE

THIRD ANGLE PROJECTION

ALL DIMENSIONS IN mm

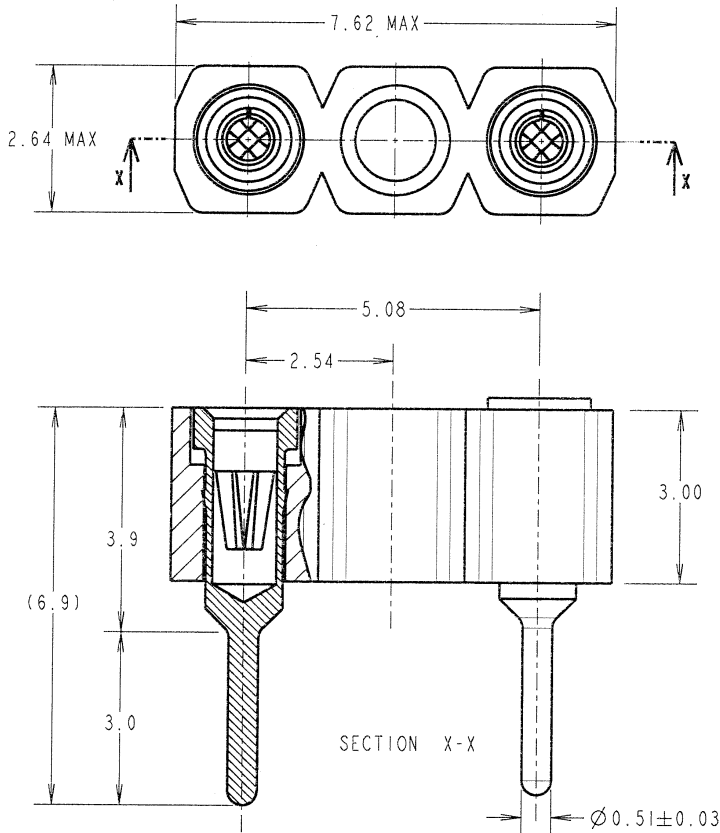

SPECIFICATION:

MATERIAL:
 MOULDING (01 FINISH) = GLASS-FILLED POLYESTER BLACK, UL94V-0
 MOULDING (42 FINISH) = GLASS-FILLED POLYAMIDE 46 BLACK, UL94V-0
 CONTACT SHELL = BRASS
 CONTACT CLIP = BERYLLIUM COPPER

FINISH:
 CONTACT SHELL = 5.0µ 100% TIN
 CONTACT CLIP = GOLD FLASH

ELECTRICAL:
 CURRENT RATING AT 25°C = 1.5A MAX
 CURRENT RATING AT 85°C = 0.25A MAX
 CONTACT RESISTANCE (INITIAL) = 15 MILLIOHMS MAX
 CONTACT RESISTANCE (AFTER CONDITIONING) = 23 MILLIOHMS MAX
 INSULATION RESISTANCE (INITIAL) = 1,000 MEGOHMS MIN
 INSULATION RESISTANCE (AFTER CONDITIONING) = 100 MEGOHMS MIN

MECHANICAL:
 INSERTION FORCE (∅0.46mm GAUGE) = 5N MAX
 WITHDRAWAL FORCE (∅0.46mm GAUGE) = 0.5N MIN
 DURABILITY = 1,000 OPERATIONS

ENVIRONMENTAL:
 OPERATING TEMPERATURE = -55°C TO +125°C

FOR COMPLETE MECHANICAL AND ELECTRICAL SPECIFICATION, SEE COMPONENT SPECIFICATION C004X (LATEST ISSUE).

NOTES:

1. RECOMMENDED PIN SIZE = ∅0.46mm.
2. RECOMMENDED PCB HOLE SIZE = ∅0.80mm.

ORDER CODE:

D2899-XX

FINISH:

- 01 = GOLD CLIP / TIN SHELL
- 42 = GOLD CLIP / 100% TIN SHELL

JMB	4	10.10.05	8770
NAME	ISS.	DATE	C/NOTE
APPROVED:			
CHECKED:			
DRAWN:	J. KEIR		
CUSTOMER REF.:			
ASSEMBLY DRG:			

HARWIN

THIS DRAWING AND ANY INFORMATION OR DESCRIPTIVE MATTER SET OUT HEREON ARE CONFIDENTIAL AND COPYRIGHT PROPERTY OF THE HARWIN GROUP AND MUST NOT BE DISCLOSED, LOANED, COPIED OR USED FOR MANUFACTURING, TENDERING OR FOR ANY OTHER PURPOSE WITHOUT THEIR WRITTEN PERMISSION.

TOLERANCES

X. = ±1mm
 X.X = ±0.25mm
 X.XX = ±0.10mm
 X.XXX = ±0.01mm
 ANGLES = ±5°
 UNLESS STATED

MATERIAL:

SEE ABOVE

FINISH:

SEE ABOVE

S/AREA:

mm²

TITLE:

3-WAY I.C. SOCKET
 WITH CENTRE SOCKET REMOVED

DRAWING NUMBER:

D2899-XX

SHT
 2
 OF
 2

HARWIN INC
 U.S.A.
 TEL: (812) 542 2540
 FAX: (812) 542 2541

HARWIN PLC
 U.K.
 TEL: 023 9231 4545
 FAX: 023 9231 4590

HARWIN PTE
 SINGAPORE
 TEL: 65 6779 4909
 FAX: 65 6779 3868