

## Description

Miniaturised single pole press-to-reset cycling trip free thermal circuit breaker designed for automotive fuse block installation. Extends the benefits of circuit breaker performance and convenience to applications which are cost critical. Manual release option.

## Typical applications

Extra low voltage wiring systems on all types of vehicles and marine craft.

## Ordering information

<b>Type No.</b>	
<b>1610</b>	single pole automotive circuit breaker
<b>Voltage rating</b>	
<b>21</b>	DC 28 V
<b>H2</b>	DC 28 V, with manual release facility (type III to SAE J 553)
<b>92</b>	DC 12 V, autoreset (type I to SAE J 553)
<b>Current ratings</b>	
<b>6 8 10 15 20 25 A</b>	
<b>1610 - 21 - 8 A</b> ordering example	

## Current ratings, typical voltage drop values and actuator colours

Current rating (A)	Voltage	Actuator colour drop (mV)	(manual release)
6	< 150	mossy-green	(approximating RAL 6005)
8	< 150	honey	(approximating RAL 1005)
10	< 150	red	(approximating RAL 3020)
15	< 150	blue	(approximating RAL 5012)
20	< 150	yellow	(approximating RAL 1018)
25	< 150	pearl	(approximating RAL 1013)
30	< 150	light-green	(approximating RAL 6018)

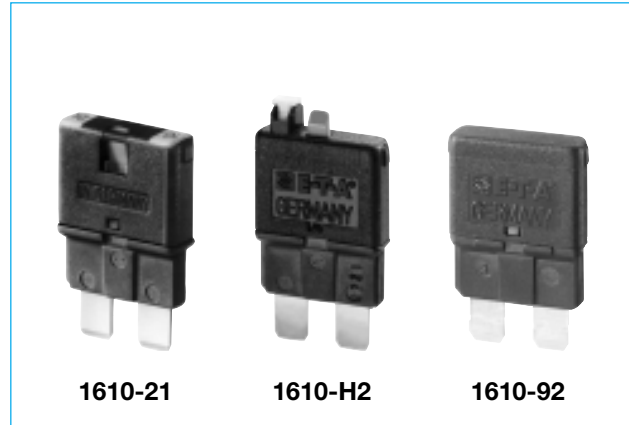

## Technical data

Voltage rating	1610-92: DC 12 V 1610-21/1610-H2: DC 32 V
Current ratings	6...25 A (30 A upon request)
Service short-circuit breaking capacity	300 operations at ≤ 50 A
Reset period for 1610-92 (at 23 °C)	≤ 15 s
Ambient temperature	-30...+60 °C (-22...+140 °F)
Degree of protection (IEC 60529/DIN 40050)	operating area IP30 (-21/-H2) operating area IP54 (-92) terminal area IP00
Ultimate short-circuit breaking capacity	≥ 3 break operations at 150 A, or ≥ 1 break operation at 2,000 A
Vibration (with mounting socket 12)	5 g (57-500 Hz), ±0.38 mm (10-57 Hz) to IEC 60068-2-6, test Fc 10 frequency cycles/axis
Shock (with mounting socket 12)	25 g (11 ms) to IEC 60068-2-27, test Ea
Corrosion	96 hours at 5 % salt mist, to IEC 60068-2-11, test Ka
Humidity	240 hours at 95 % RH, to IEC 60068-2-3, test Ca
Mass	approx. 5 g

### N.B.

It is good practice to switch off the vehicle's ignition system before re-setting the circuit breaker. Free travel of the actuator must be ensured.

1

## Dimensions

### 1610-21

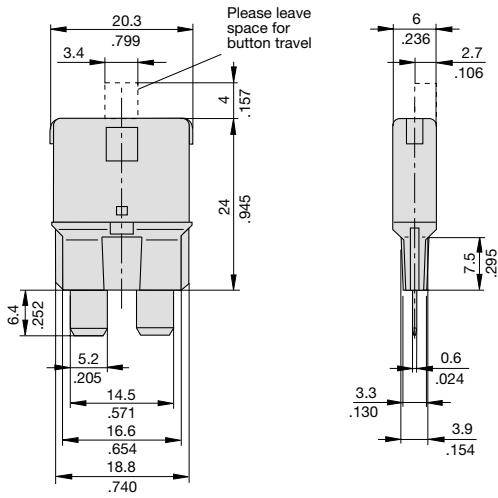

### 1610-H2

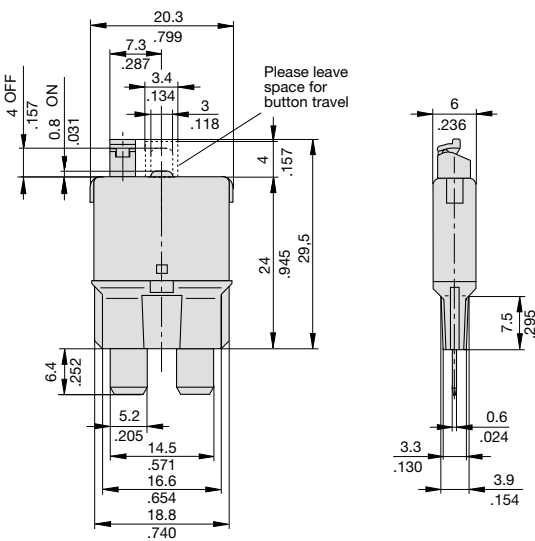

### 1610-92

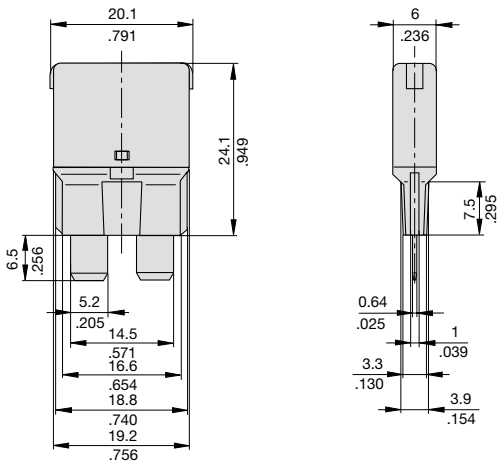

## Internal connection diagram

### 1610-21

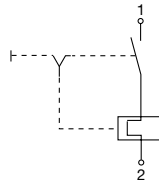

### 1610-H2

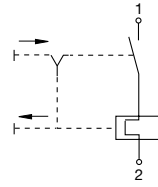

### 1610-92

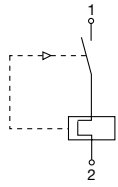

## Typical time/current characteristic curve

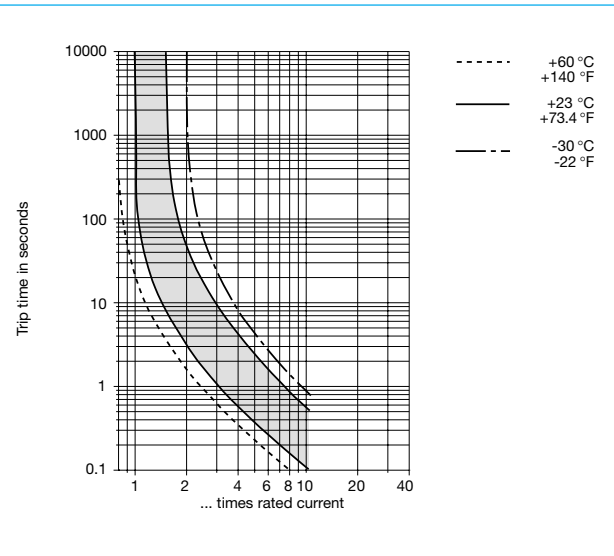

This is a metric design and millimeter dimensions take precedence ( $\frac{mm}{inch}$ )

## Accessories

### Socket 12-P10

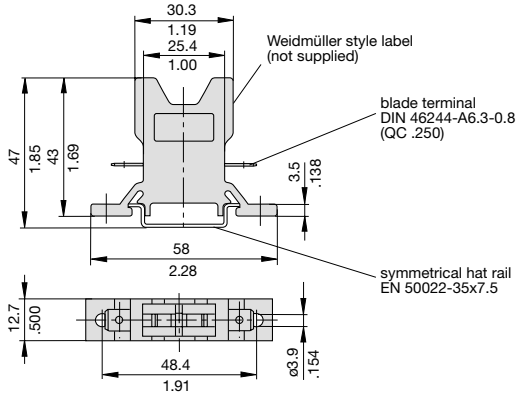

### Socket 12-J20

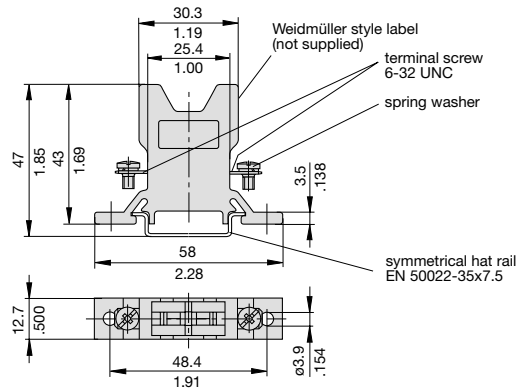

### Socket 12-A10

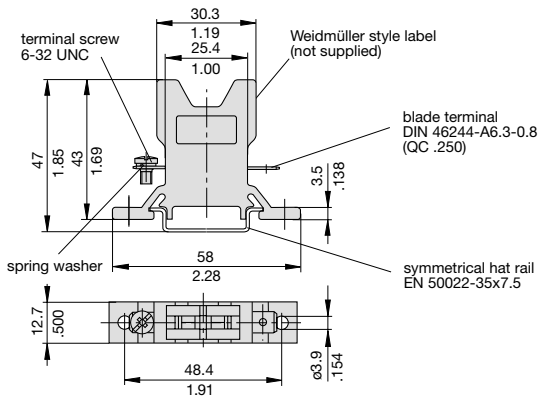

### Dimensions for surface mounting

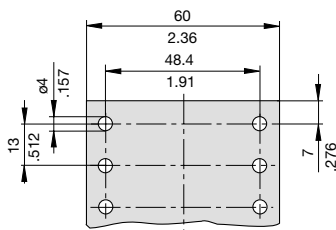

**Other sockets available to special order**  
**Labels:** Weidmüller, D-33102 Paderborn

## Ordering information Mounting socket 12

### Type No.

12 Mounting socket

### Terminal design

P10 blade terminals A 6.3-0.8 (QC .250)

J20 screw terminals 6-32 UNC

A10 1 blade terminal A6.3-0.8 (QC .250) / 1 screw terminal 6-32 UNC

### Version

(blank) single socket

20 two-way

30 three-way

40 four-way

60 six-way

12 - P10 - 20 ordering example

**Labels:** Weidmüller, D-33102 Paderborn

## Accessories for mounting socket 12

### Connector bus links -P10

X 210 588 01/ 1.5 mm<sup>2</sup> (AWG 16), brown (up to 13 A max. load)

X 210 588 02/ 2.5 mm<sup>2</sup> (AWG 14), black (up to 20 A max. load)

X 210 588 03/ 2.5 mm<sup>2</sup> (AWG 14), red (up to 20 A max. load)

X 210 588 04/ 2.5 mm<sup>2</sup> (AWG 14), blue (up to 20 A max. load)

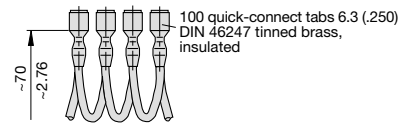

### Bus bar (supplied as a complete package)

(up to 100 A max. load)

X 211 157 01 with terminal

X 211 157 02 without terminal

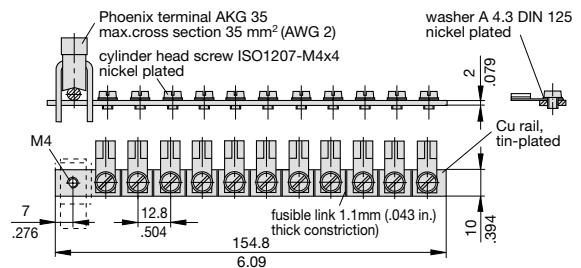

This is a metric design and millimeter dimensions take precedence ( $\frac{mm}{inch}$ )

All dimensions without tolerances are for reference only. In the interest of improved design, performance and cost effectiveness the right to make changes in these specifications without notice is reserved. Product markings may not be exactly as the ordering codes. Errors and omissions excepted.