

## Description

Single, two and three pole magnetic circuit breakers with trip-free mechanism and push/pull on/off manual actuation. A choice of fast magnetic only or hydraulically delayed switching characteristics (Stype MO or HM CBE to EN 60934) ensures suitability for a wide range of applications. Convenient threadneck panel or plug-in mounting, and with a white push button indicator band showing clearly the tripped/off position. Available with auxiliary contacts (1 x N/O, 1 x N/C) for status signalling and fitted with an unprotected shunt tap terminal as standard. Approved to CBE standard EN 60934 (IEC 60934).

## Typical application

Control equipment, communications systems, power semiconductors.

## Standard current ratings and typical internal resistance values

Current rating (A)	Internal resistance ( $\Omega$ ) per pole		
	curve -F4/F5	curves -E1/H1/R1	curves -E2/H2/R2
0.02	583	2441	2449
0.05	94	376	365
0.08	35.8	148	144
0.1	23	94	84
0.15	9.9	39	38
0.2	5	23	22.4
0.3	2.44	9.9	9.7
0.5	0.79	3.16	3.1
0.75	0.39	1.55	1.51
1	0.25	0.79	0.77
1.25	0.15	0.58	0.56
1.5	0.10	0.37	0.36
1.75	0.083	0.30	0.29
2	0.059	0.20	0.24
2.5	0.044	0.146	0.138
3	0.028	0.10	0.099
4	< 0.02	0.059	0.057
5	< 0.02	0.040	0.038
6	< 0.02	0.026	0.026
8	< 0.02	< 0.02	< 0.02
10	< 0.02	< 0.02	< 0.02
12	< 0.02	< 0.02	< 0.02
15	< 0.02	< 0.02	< 0.02
16	< 0.02	< 0.02	< 0.02
20	< 0.02	< 0.02	< 0.02
25	< 0.02*	< 0.02	< 0.02
30	< 0.02*	< 0.02	< 0.02
40		< 0.02	
50		< 0.02	

\* 50 % ON duty / 60 min.

## Approvals

Authority	Voltage ratings	Current ratings
VDE (EN 60934)	3 AC 415 V, AC 240 V, DC 80 V	0.02...30 A DC 80 V
UL 1077, CSA	DC 80 V 3 AC 250 V; AC 250 V	0.02...50 A 1, 2 pole 0.02...30 A 1,2,3 pole
UL 489 A	DC 80 V	0.05...30 A 1, 2 pole
BV	AC 250 V, DC 65 V	0.1...30 A
CCC	3 AC 415 V, AC 240 V, DC 80 V DC 80 V	0.02...30 A 0.02...50 A 1, 2 pole



## Technical data

For further details please see chapter: Technical Information

Voltage rating	3 AC 415 V; AC 240 V, 50/60 Hz; DC 80 V
Current ratings	0.02...50 A single pole (40+50 A DC only) 0.02...30 A multipole
Auxiliary circuit	1 A, AC 240 V/DC 65 V; 0.5 A, DC 80 V

Typical life	
3 AC 415 V, AC 240 V:	0.02...30 A 6,000 operations at 1 x I <sub>N</sub> , inductive 10,000 operations at 1xI <sub>N</sub> , resistive
DC 80 V:	0.02...25 A 6,000 operations at 1 x I <sub>N</sub> , inductive 0.02...30 A 10,000 operations at 1 x I <sub>N</sub> , resistive 40 + 50 A 5,000 operations at 1 x I <sub>N</sub> , resistive

Ambient temperature	-40...+85 °C (-40...+185 °F)	
Insulation co-ordination (IEC 60664 and 60664A)	rated impulse withstand voltage 2.5 kV	pollution degree 2
	reinforced insulation in operating area	

Dielectric strength (IEC 60664 and 60664A)	test voltage
operating area	AC 3,000 V
pole to pole (2 + 3 pole)	AC 1,500 V
main to auxiliary circuit	AC 1,500 V
aux. circuit 11-12/23-24	AC 1,000 V
switching to trip circuit (-X)	AC 1,500 V

Insulation resistance	> 100 M $\Omega$ (DC 500 V)
-----------------------	-----------------------------

Interrupting capacity I <sub>cn</sub>	1,200 A at AC; 2,000 A at DC
---------------------------------------	------------------------------

Interrupting capacity (UL 1077)	AC:	I <sub>N</sub>	0.02...20 A	25...30 A
		1 pole	AC 250 V/3,500A	AC 250 V/3,500A
		2 pole	AC 250 V/3,500A	AC 250 V/5,000A
	DC:	3 pole	3AC 250V/3,500A	3AC250V/5,000A
		1 pole	0.02...50 A	DC 80 V/3,500 A
		2 pole	0.02...30 A	DC 80 V/3500 A

Interrupting capacity (UL 489A)	2000 A
---------------------------------	--------

Degree of protection (IEC 60529/DIN 40050)	operating area IP40 terminal area IP00
--------------------------------------------	-------------------------------------------

Vibration	
with button down:	10 g (57-2000 Hz), $\pm 0.76$ mm (10-57 Hz) at 0.9 x I <sub>N</sub>
other mounting planes:	10 g (57-2000 Hz) at I <sub>N</sub> to IEC 60068-2-6, test Fc 10 frequency cycles/axis

Shock	100 g (11 ms) at 1xI <sub>N</sub> , directions 1,2,3,4,5 100 g (11 ms) at 0.8 x I <sub>N</sub> , direction 6 to IEC 60068-2-27, test Ea
-------	-----------------------------------------------------------------------------------------------------------------------------------------------

Corrosion	96 hours at 5 % salt mist, to IEC 60068-2-11, test Ka
-----------	-------------------------------------------------------

Humidity	240 hours at 95 % RH to IEC 60068-2-3, test Ca
----------	------------------------------------------------

Mass	approx. 70 g per pole
------	-----------------------

## Ordering information

<b>Type No.</b>	8340	Magnetic push/pull circuit breaker
<b>Mounting</b>	<b>G</b>	threadneck panel mounting
<b>Threadneck design</b>	<b>2</b>	M12x1
<b>Number of poles (main current paths)</b>	<b>0</b>	single pole, switch only
	<b>1</b>	single pole, protected
	<b>2</b>	two pole, protected
	<b>3</b>	three pole, protected
	<b>5</b>	two pole, protected on one pole only
<b>Panel hardware</b>	<b>0</b>	without panel hardware
	<b>1</b>	with hex nut M12x1 and washer 12/15
<b>Terminal design</b>	<b>P1</b>	blade terminals A6.3-0.8mm (QC.250)
	<b>N1</b>	blade terminals A6.3-0.8mm (QC.250) with -A3 terminal (blade terminal) A6.3-0.8mm (QC.250)
	<b>G3</b>	screw terminals M4* with -A3 terminal (blade terminals) A6.3-0.8mm (QC.250)
	<b>G4</b>	screw terminals M5* with -A3 terminal (blade terminals) A6.3-0.8mm (QC.250)
	<b>K3</b>	screw terminals M4*
	<b>K4</b>	screw terminals M5*
	<b>R1</b>	round connectors ø6
	<b>X1</b>	blade terminals A6.3-0.8mm (QC.250), separate switching and trip circuit
<b>Characteristic curve</b>	<b>F4</b>	instantaneous trip: magn. 1.5-2.2xI <sub>N</sub> DC (I <sub>N</sub> ≤ 30 A)
	<b>F5</b>	magn. 1.2-1.7xI <sub>N</sub> AC 50/60 Hz (I <sub>N</sub> ≤ 30A)
	<b>E1</b>	short delay: magn.-hydr. 1.01-1.4 I <sub>N</sub> , DC
	<b>E2</b>	short delay: magn.-hydr. 1.01-1.4 I <sub>N</sub> , AC 50/60 Hz
	<b>H1</b>	medium delay: magn.-hydr. 1.01-1.4 I <sub>N</sub> , DC
	<b>H2</b>	medium delay: magn.-hydr. 1.01-1.4 I <sub>N</sub> , AC 50/60Hz
	<b>R1</b>	long delay: magn.-hydr. 1.01-1.5 I <sub>N</sub> , DC
	<b>R2</b>	long delay: magn.-hydr. 1.01-1.5 I <sub>N</sub> , AC50/60Hz
<b>Actuator colour</b>	<b>A</b>	black with white trip indicator band
<b>Actuator marking</b>	<b>0</b>	without marking
	<b>4</b>	rated current (legible with location pin above) standard
	<b>7</b>	rated current (legible with location pin below)
<b>Auxiliary contacts</b>	<b>H0</b>	without auxiliary contacts
	<b>H1</b>	with auxiliary contacts
	<b>H2</b>	with auxiliary contacts on pole 1 only (2 and 3 pole types)
	<b>H3</b>	with auxiliary contacts on poles 1 and 3 (3 pole type)
<b>Auxiliary contact function</b>	<b>1</b>	one each N/O and N/C
	<b>2</b>	1 pair N/O (23/24)
	<b>3</b>	1 pair N/C (11/12)
<b>Auxiliary contact terminal design</b>	<b>1</b>	blade terminals A6.3-0.8 mm
<b>Current ratings (optional)</b>		0.02...50 A
<b>Approval (optional)</b>	<b>U</b>	UL 489 A

8340 - G 2 1 1 - N1 F4 - A 4 H1 1 1 - 8 A - U ordering example

\*M4 thread recommended for I<sub>N</sub> > 20 A  
M5 thread for I<sub>N</sub> > 40 A

## Dimensions (1 pole)

### Terminal design -N

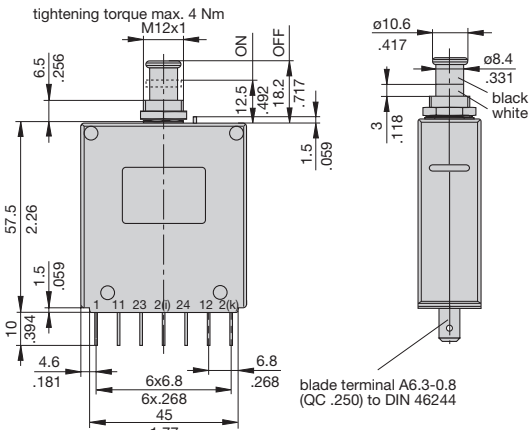

### Terminal design -G/-K

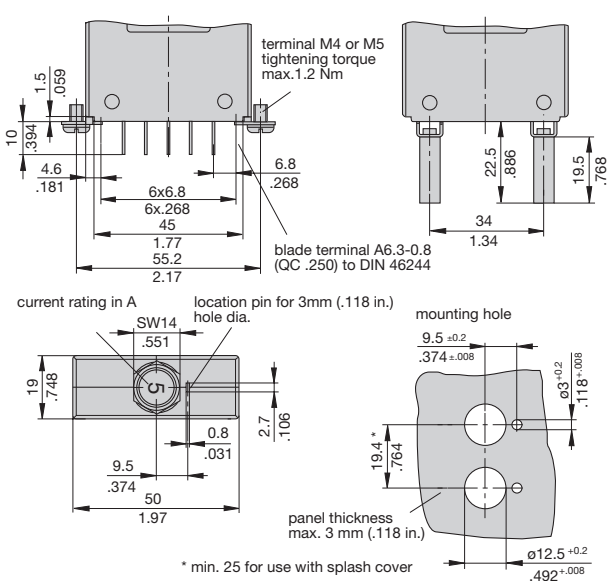

### Terminal design -R

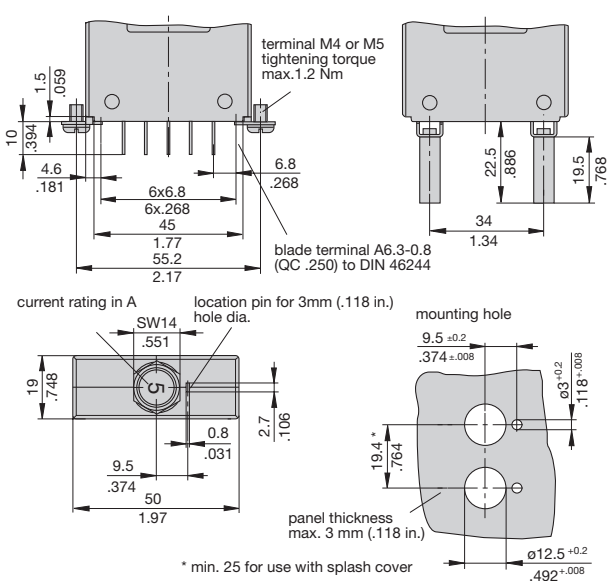

This is a metric design and millimeter dimensions take precedence ( $\frac{mm}{inch}$ )

## Dimensions (2 pole)

## Dimensions (3 pole)

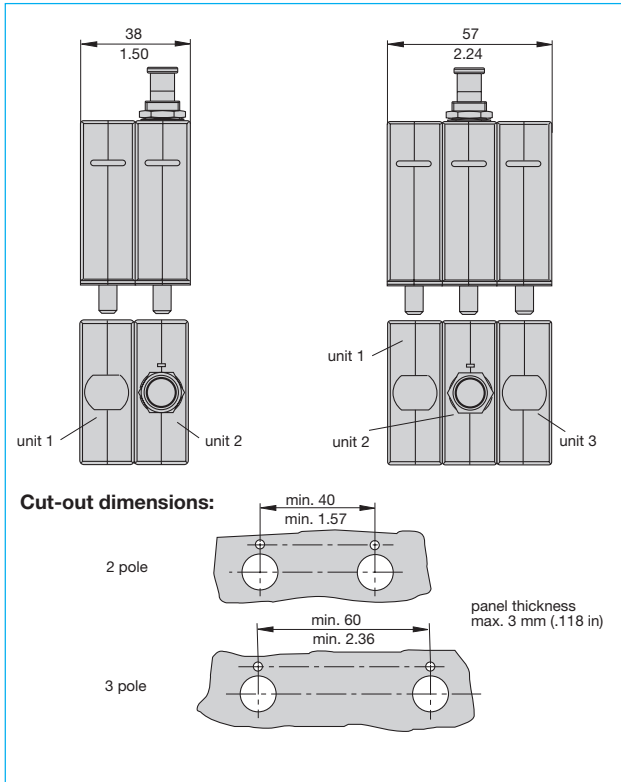

## Installation drawings

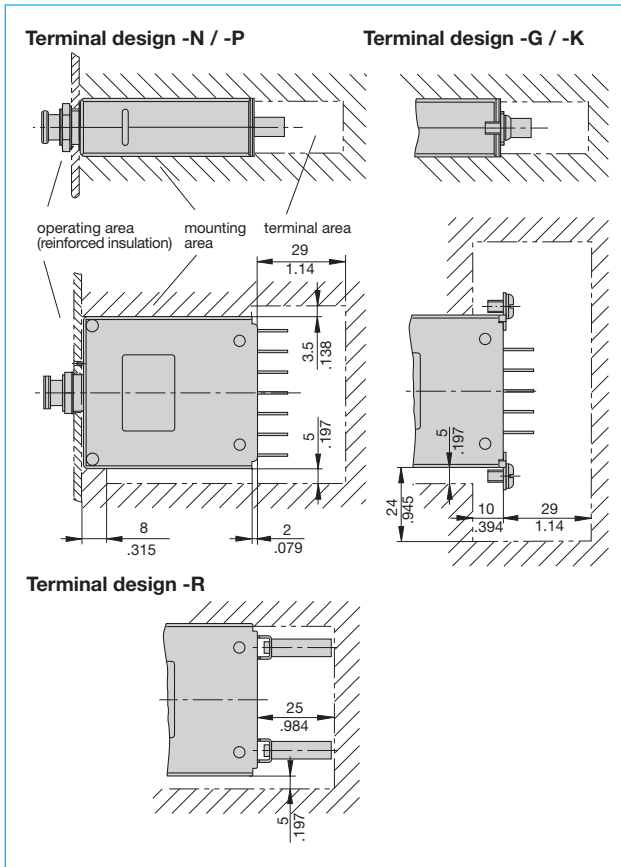

## Internal connection diagrams

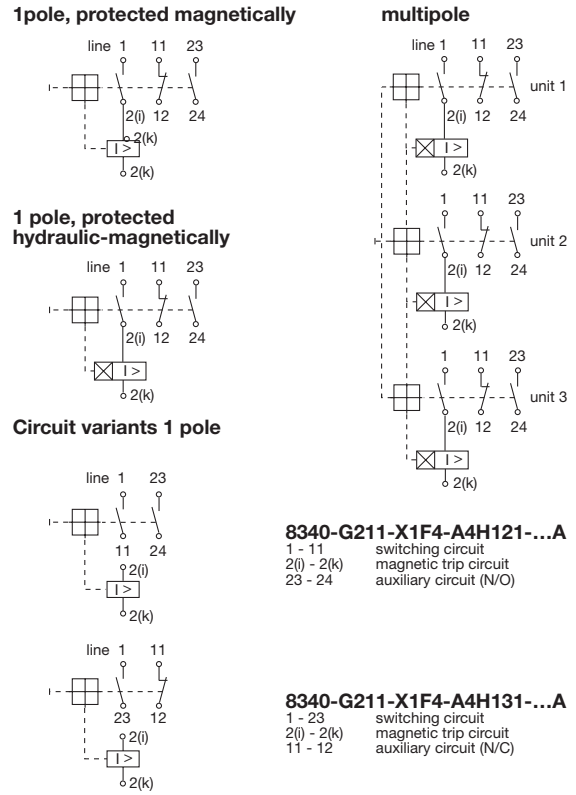

3

## Shock directions / Mounting attitudes

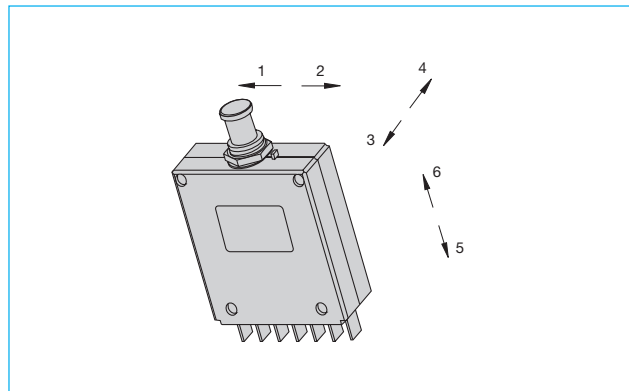

This is a metric design and millimeter dimensions take precedence ( $\frac{mm}{inch}$ )

## Typical time/current characteristics

**Curve F4 for DC, magnetic (undelayed)**

( $I_N > 20$  A, 50% ON period, 60 min.) at +23 °C / +73.4 °F

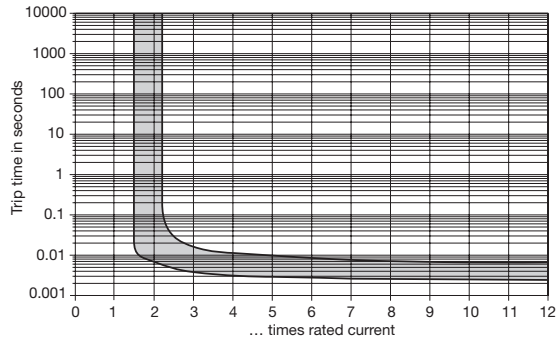

**Curve F5 for AC 50/60 Hz, magnetic (undelayed)**

( $I_N > 20$  A, 50% ON period, 60 min.) at +23 °C / +73.4 °F

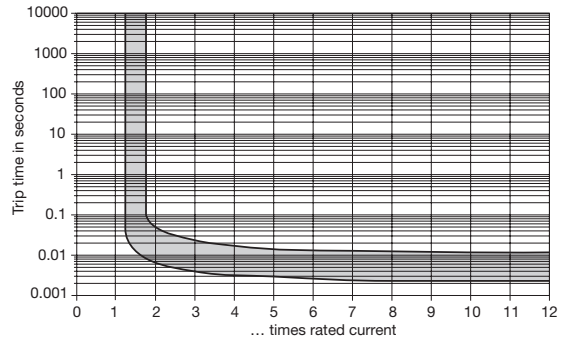

**Short delay curves E1 for DC and E2 for AC 50/60 Hz, hydraulic-magnetic**

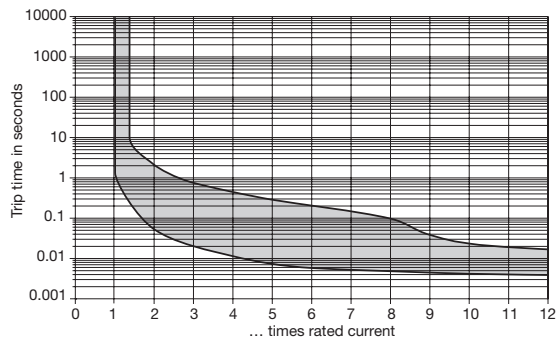

**Medium delay curves H1 for DC and H2 for AC 50/60 Hz, hydraulic-magnetic**

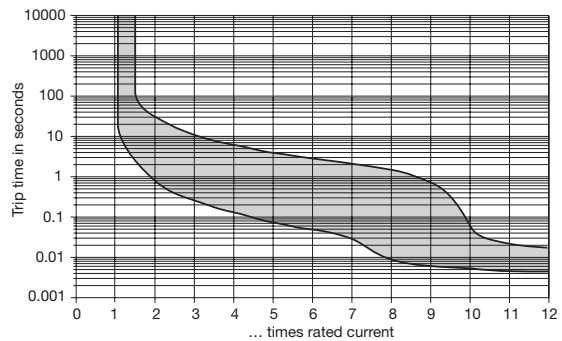

**Long delay curves R1 for DC and R2 for AC 50/60 Hz, hydraulic-magnetic**

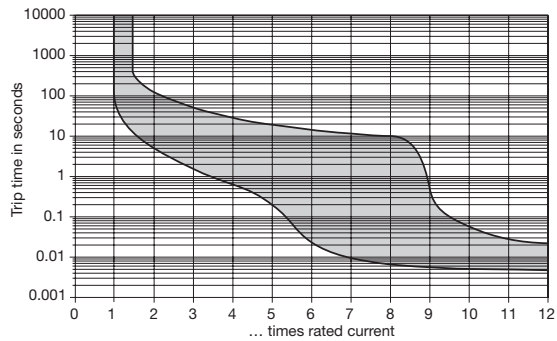

**N.B.** Curves E1, E2, H1, H2, R1 and R2 will only be maintained if the escutchen is mounted on a vertical surface.

**Other curves upon request ( e. g. impulse delay).**

## Accessories

### Socket 18-P10-Si

(for ratings >16 A please contact E-T-A)

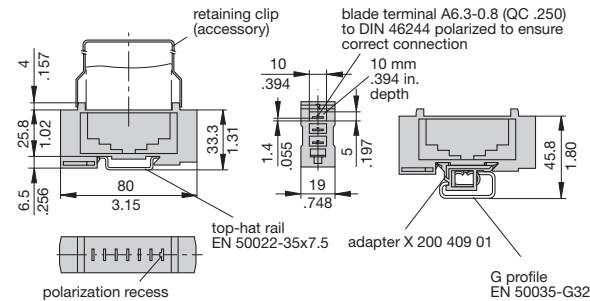

### Polarized socket with adapter 18-P10-Si-20025

### Bus bar (10-way) (supplied as a complete package) for type 18 socket

(for max. 100 A continuous load), more positions available on request

#### X 211 158 01 with terminal

#### X 211 158 02 without terminal

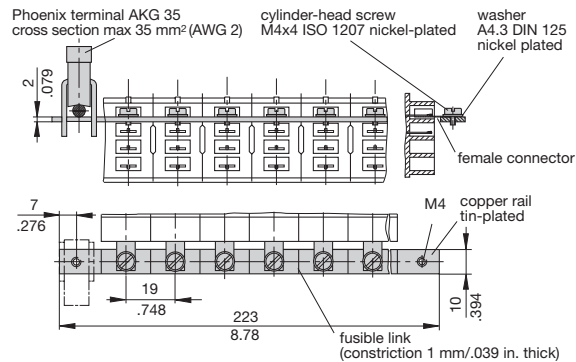

### Insulated sleeving for bus bars Y 303 824 11

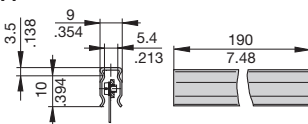

### Retaining clip for socket 18-P10-Si Y 300 579 11

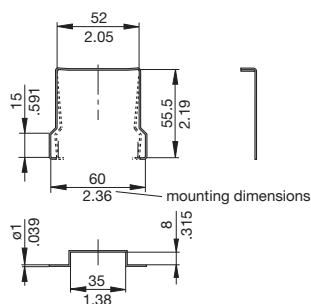

### Connector bus link -P10

- X 210 588 01/1.5 mm<sup>2</sup> (AWG 16), brown (up to 13 A max. load)
- X 210 588 02/2.5 mm<sup>2</sup> (AWG 14), black (up to 20 A max. load)
- X 210 588 03/2.5 mm<sup>2</sup> (AWG 14), red (up to 20 A max. load)
- X 210 588 04/2.5 mm<sup>2</sup> (AWG 14), blue (up to 20 A max. load)

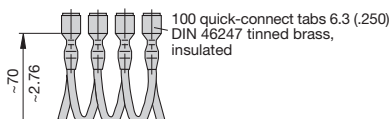

### Hex nut Y 300 116 02

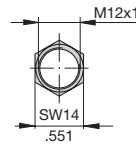

### Spring washer Y 300 118 03

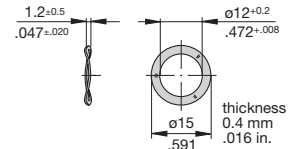

### Accessories for push button

#### Splash cover with hex nut and O ring (IP66)

#### X 200 801 08 (nickel plated hex nut M12x1, splash cover transparent)

#### X 200 801 03 (black finish hex nut M12x1, splash cover black)

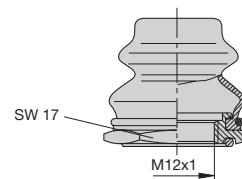

#### Splash seal, black, hex nut and O ring (IP54)

#### X 200 802 01 (nickel plated hex nut M12x1, splash seal black)

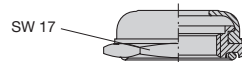

#### Actuator extension

#### X 200 803 01 (black button)

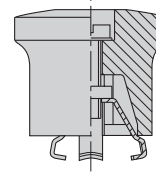

This is a metric design and millimeter dimensions take precedence ( $\frac{\text{mm}}{\text{inch}}$ )

All dimensions without tolerances are for reference only. In the interest of improved design, performance and cost effectiveness the right to make changes in these specifications without notice is reserved. Product markings may not be exactly as the ordering codes. Errors and omissions excepted.