

| | |
|------|--|
| 5/2 | Introduction |
| | 3RV Motor Starter Protectors up to 100 A |
| 5/4 | General data |
| 5/5 | For motor protection |
| 5/8 | For motor protection with overload relay function |
| 5/9 | For starter combinations |
| 5/10 | For transformer protection |
| 5/11 | For fuse monitoring |
| 5/12 | For plant protection according to UL 489 / CSA C22.2 No.5-02 |
| 5/13 | For distance protection |
| | <u>Accessories</u> |
| 5/14 | Mountable accessories |
| 5/19 | Busbar accessories |
| 5/22 | Rotary operating mechanisms |
| 5/24 | Mounting accessories |
| 5/28 | Enclosures and front plates |
| | Overload Relays |
| 5/31 | General data |
| | <u>3RB2 Solid-State Overload Relays</u> |
| 5/35 | 3RB20, 3RB21 for standard applications |
| 5/44 | 3RB22, 3RB23 for high-feature applications |
| 5/49 | Accessories |
| | <u>3RU1 Thermal Overload Relays</u> |
| 5/51 | 3RU11 for standard applications |
| 5/55 | Accessories |

Protection Equipment

Introduction

Overview



| Type | 3RV10 | 3RV11 | 3RV13 | 3RV14 | 3RV16 | 3RV16 | 3RV17 |
|---|-------------------------------------|-----------------------------------|----------------------|----------------------------------|----------------------|---------------------------------------|-----------------------------|
| 3RV1 motor starter protectors up to 100 A | | | | | | | |
| Applications | | | | | | | |
| Plant protection | ✓ ¹⁾ | ✓ ¹⁾ | – | – | – | – | ✓ |
| Motor protection | ✓ | – | – | – | – | – | – |
| Motor protection with overload relay function | – | ✓ | – | – | – | – | – |
| Starter combinations | – | – | ✓ | – | – | – | – |
| Transformer protection | – | – | – | ✓ | – | – | – |
| Fuse monitoring | – | – | – | – | ✓ | – | – |
| Voltage transformer circuit-breakers for distance protection | – | – | – | – | – | ✓ | – |
| Size | S00, S0, S2, S3 | S0, S2, S3 | S0, S2, S3 | S0, S2 | S00 | S00 | S3 |
| Rated current I_n | | | | | | | |
| Size S00 | A up to 12 | – | – | – | up to 0.2 | up to 3 | – |
| Size S0 | A up to 25 | up to 25 | up to 25 | up to 20 | – | – | – |
| Size S2 | A up to 50 | up to 50 | up to 50 | up to 40 | – | – | – |
| Size S3 | A up to 100 | up to 100 | up to 100 | – | – | – | up to 70 |
| Rated operational voltage U_e | V 690 AC ²⁾ | 690 AC ²⁾ | 690 AC ²⁾ | 690 AC ²⁾ | 690 AC ²⁾ | 400 AC | 690 AC |
| Rated frequency | Hz 50/60 | 50/60 | 50/60 | 50/60 | 50/60 | 16 ² / ₃ ... 60 | 50/60 |
| Trip class | CLASS 10 CLASS 20 | CLASS 10 | – | CLASS 10 | – | – | – |
| Thermal overload release | A 0.11 ... 0.16 up to 80 ... 100 | 0.11 ... 0.16 up to 80 ... 100 | None ³⁾ | 0.11 ... 0.16 up to 28 ... 40 | 0.2 | 1.4 ... 3 | 10 ... 70 Non-adjustable |
| Overcurrent release | | | | | | | |
| Multiple of the rated current | 13 times | 13 times | 13 times | 20 times | 6 times | 4 to 7 times | 13 times |
| Short-circuit switching capacity I_{cu} at 400 V AC | kA 50/100 | 50/100 | 50/100 | 50/100 | 100 | 50 | 100 |
| Accessories | | | | | | | |
| For sizes | S00 S0 S2 S3 | S0 S2 S3 | S0 S2 S3 | S0 S2 | S00 | S00 | S3 |
| Auxiliary switch | ✓ ✓ ✓ ✓ | ✓ ✓ ✓ | ✓ ✓ ✓ | ✓ ✓ | ✓ | ✓ | ✓ ⁵⁾ |
| Alarm switch | – ✓ ✓ ✓ | ✓ ✓ ✓ | ✓ ✓ ✓ | ✓ ✓ | – | – | – |
| Undervoltage release | ✓ ✓ ✓ ✓ | ✓ ✓ ✓ | ✓ ✓ ✓ | ✓ ✓ | ✓ | ✓ | ✓ |
| Shunt release | ✓ ✓ ✓ ✓ | ✓ ✓ ✓ | ✓ ✓ ✓ | ✓ ✓ | ✓ | ✓ | ✓ |
| Isolator module | – ✓ ✓ – | ✓ ✓ – | ✓ ✓ – | ✓ ✓ | – | – | – |
| Insulated 3-phase busbar system | ✓ ✓ ✓ – | – ✓ – | ✓ ✓ – | ✓ ✓ | ✓ | ✓ | – |
| Busbar adapter for motor starter protectors | ✓ ✓ ✓ ✓ | ✓ ✓ ✓ | ✓ ✓ ✓ | ✓ ✓ | ✓ | ✓ | – |
| Door-coupling rotary operating mechanism | – ✓ ✓ ✓ | ✓ ✓ ✓ | ✓ ✓ ✓ | ✓ ✓ | – | – | ✓ |
| Remote motorized operating mechanism | – – ✓ ✓ | – ✓ ✓ | – ✓ ✓ | – ✓ | – | – | – |
| Link module | ✓ ✓ ✓ ✓ | ✓ ✓ ✓ | ✓ ✓ ✓ | ✓ ✓ | ✓ | ✓ | – |
| Enclosure for surface mounting | ✓ ✓ ✓ – | ✓ ✓ – | ✓ ✓ – | ✓ ✓ | ✓ | ✓ | – |
| Enclosure for flush mounting | ✓ ✓ – – | ✓ – – | ✓ – – | ✓ – | ✓ | ✓ | – |
| Front plate | ✓ ✓ ✓ ✓ | ✓ ✓ ✓ | ✓ ✓ ✓ | ✓ ✓ | ✓ | ✓ | – |
| Cage Clamp infeed system | ✓ ⁴⁾ ✓ – – | – – – | ✓ – – | ✓ – | – | – | – |

1) For symmetrical loading of the three phases.

2) With molded-plastic enclosure 500 V AC.

3) For overload protection of the motors, appropriate overload relays must be used.

4) Only for motor starter protectors with Cage Clamp terminals.

5) Only lateral auxiliary switches



| Type | | 3RU11 | 3RB20 | 3RB21 | 3RB22/3RB23 |
|---|----|--------------------------------|--------------------------------|--------------------------------|--------------------------------|
| Overload relays up to 630 A | | | | | |
| Applications | | | | | |
| Plant protection | | ✓ ¹⁾ | ✓ ¹⁾ | ✓ ¹⁾ | ✓ ¹⁾ |
| Motor protection | | ✓ | ✓ | ✓ | ✓ |
| Alternating current, 3-phase | | ✓ | ✓ | ✓ | ✓ |
| Alternating current, 1-phase | | ✓ | – | – | ✓ |
| Direct current | | ✓ | – | – | – |
| Size of contactor | | S00, S0, S2, S3 | S00 ... S12 | S00 ... S12 | S00 ... S12 |
| Rated operational current I_e | | | | | |
| Size S00 | A | up to 12 | up to 12 | up to 12 | } up to 25 |
| Size S0 | A | up to 25 | up to 25 | up to 25 | |
| Size S2 | A | up to 50 | up to 50 | up to 50 | } up to 100 |
| Size S3 | A | up to 100 | up to 100 | up to 100 | |
| Size S6 | A | – | up to 200 | up to 200 | up to 200 |
| Size S10/S12, size 14 (3TF6) | A | – | up to 630 | up to 630 | up to 630 |
| Rated operational voltage U_e | V | 690 / 1000 AC ²⁾ | 690 / 1000 AC ²⁾ | 690 / 1000 AC ²⁾ | 690 / 1000 AC ³⁾ |
| Rated frequency | Hz | 50/60 | 50/60 | 50/60 | 50/60 |
| Trip class | | CLASS 10 | CLASS 10, CLASS 20 | CLASS 5, 10, 20, 30 adjustable | CLASS 5, 10, 20, 30 adjustable |
| Thermal overload release | A | 0.11 ... 0.16 up to 80 ... 100 | – | – | – |
| | A | – | 0.1 ... 0.4 up to 160 ... 630 | 0.1 ... 0.4 up to 160 ... 630 | 0.3 ... 3 up to 63 ... 630 |
| Solid-state overload release | A | – | 0.1 ... 0.4 up to 160 ... 630 | 0.1 ... 0.4 up to 160 ... 630 | 0.3 ... 3 up to 63 ... 630 |
| | A | – | – | – | – |
| Rating for induction motor at 400 V AC | kW | 0.04 up to 45 | 0.04 ... 0.09 up to 90 ... 450 | 0.04 ... 0.09 up to 90 ... 450 | 0.09 ... 1.1 up to 37 ... 450 |
| | kW | – | – | – | – |
| Accessories | | | | | |
| For sizes | | S00 S0 S2 S3 | S00 S0 S2 S3 S6 S10/S12 | S00 S0 S2 S3 S6 S10/S12 | S00 S0 S2 S3 S6 S10/S12 |
| Terminal brackets for stand-alone installation | | ✓ ✓ ✓ ✓ | ✓ ✓ 4) 4) 4) 4) | ✓ ✓ 4) 4) 4) 4) | 4) 4) 4) 4) 4) 4) |
| Mechanical RESET | | ✓ ✓ ✓ ✓ | ✓ ✓ ✓ ✓ ✓ ✓ | ✓ ✓ ✓ ✓ ✓ ✓ | – – – – – – |
| Cable release for RESET | | ✓ ✓ ✓ ✓ | ✓ ✓ ✓ ✓ ✓ ✓ | ✓ ✓ ✓ ✓ ✓ ✓ | – – – – – – |
| Electrical remote RESET | | ✓ ✓ ✓ ✓ | – – – – – – | Integrated in the unit | Integrated in the unit |
| Terminal covers | | – – ✓ ✓ | – – – ✓ ✓ ✓ | – – – ✓ ✓ ✓ | – – – ✓ ✓ ✓ |
| Sealable covers for setting knobs | | Integrated in the unit | ✓ ✓ ✓ ✓ ✓ ✓ | ✓ ✓ ✓ ✓ ✓ ✓ | ✓ ✓ ✓ ✓ ✓ ✓ |

1) The units are responsible in the main circuit for overload protection of the assigned electrical loads (e.g. motors), feeder cable and other switching and protection devices in the respective load feeder.

2) Size S3 and larger up to 1000 V AC.

3) Sizes S6 and S10/12 up to 1000 V AC.

4) Stand-alone installation without accessories is possible.

3RV Motor Starter Protectors up to 100 A

General data

Overview



S0 motor starter protectors

3RV1 motor starter protectors are compact, current limiting motor starter protectors which are optimized for load feeders. The motor starter protectors are used for switching and protecting three-phase induction motors of up to 45 kW at 400 V AC and for other loads with rated currents of up to 100 A.

Type of construction

The motor starter protectors are available in four sizes:

- Size S00 – overall width 45 mm, max. rated current 12 A, at 400 V AC suitable for 3-phase induction motors up to 5.5 kW.
- Size S0 – overall width 45 mm, max. rated current 25 A, at 400 V AC suitable for 3-phase induction motors up to 11 kW.
- Size S2 – overall width 55 mm, max. rated current 50 A, at 400 V AC suitable for 3-phase induction motors up to 22 kW.
- Size S3 – overall width 70 mm, max. rated current 100 A, at 400 V AC suitable for 3-phase induction motors up to 45 kW.

Application

Operating conditions

3RV1 motor starter protectors are suitable for use in any climate. They are intended for use in enclosed rooms in which no severe conditions (such as dust, caustic vapors, hazardous gases) prevail. When installed in dusty and damp areas, suitable enclosures must be provided.

3RV motor starter protectors can optionally be fed from the top or from below.

The permissible ambient temperatures, the maximum switching capacities, the tripping currents and other boundary conditions can be found in the technical specifications and tripping characteristics.

3RV1 motor starter protectors are suitable for use in IT systems (IT networks). In this case, the different short-circuit breaking capacity in the IT system must be taken into account.

Since operational currents, starting currents and current peaks are different even for motors with identical power ratings due to the inrush current, the motor ratings in the selection tables are only guide values. The specific rated and start-up data of the motor to be protected is always paramount to the choice of the most suitable motor starter protector. This also applies to motor starter protectors for transformer protection.

Possible uses

The 3RV1 motor starter protectors can be used:

- For short-circuit protection
- For motor protection (also with overload relay function)
- For plant protection
- For short-circuit protection for starter combinations
- For transformer protection
- As main control and EMERGENCY-STOP switches
- For fuse monitoring
- For use in IT systems (IT networks)
- For switching of DC currents
- As voltage transformer circuit-breakers

More information is available under "Configuration".

3RV Motor Starter Protectors up to 100 A

For motor protection

Selection and ordering data

Class 10, without/with auxiliary switches

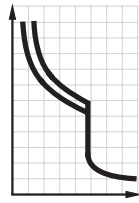

| Rated current | Suitable for three-phase induction motors ¹⁾ with P | Setting range for thermal overload release | Instantaneous overcurrent release | Short-circuit breaking capacity at 400 V AC | DT | Screw connection | PU (UNIT, SET, M) | PS* | PG | Weight per PU approx. ²⁾ |
|---------------|--|--|-----------------------------------|---|----|------------------|-------------------|-----|----|-------------------------------------|
| I_n | | | $I >$ | I_{cu} | | Order No. | Price per PU | | | kg |
| A | kW | A | A | kA | | | | | | |

Size S00



| | | | | | | | | | | |
|------|------|---------------|-----|-----|--|--|---|--------|-----|-------|
| 0.16 | 0.04 | 0.11 ... 0.16 | 2.1 | 100 | | 3RV10 11-0AA1 <input type="checkbox"/> | 1 | 1 unit | 101 | 0.245 |
| 0.2 | 0.06 | 0.14 ... 0.2 | 2.6 | 100 | | 3RV10 11-0BA1 <input type="checkbox"/> | 1 | 1 unit | 101 | 0.246 |
| 0.25 | 0.06 | 0.18 ... 0.25 | 3.3 | 100 | | 3RV10 11-0CA1 <input type="checkbox"/> | 1 | 1 unit | 101 | 0.246 |
| 0.32 | 0.09 | 0.22 ... 0.32 | 4.2 | 100 | | 3RV10 11-0DA1 <input type="checkbox"/> | 1 | 1 unit | 101 | 0.247 |
| 0.4 | 0.09 | 0.28 ... 0.4 | 5.2 | 100 | | 3RV10 11-0EA1 <input type="checkbox"/> | 1 | 1 unit | 101 | 0.250 |
| 0.5 | 0.12 | 0.35 ... 0.5 | 6.5 | 100 | | 3RV10 11-0FA1 <input type="checkbox"/> | 1 | 1 unit | 101 | 0.247 |
| 0.63 | 0.18 | 0.45 ... 0.63 | 8.2 | 100 | | 3RV10 11-0GA1 <input type="checkbox"/> | 1 | 1 unit | 101 | 0.249 |
| 0.8 | 0.18 | 0.55 ... 0.8 | 10 | 100 | | 3RV10 11-0HA1 <input type="checkbox"/> | 1 | 1 unit | 101 | 0.250 |
| 1 | 0.25 | 0.7 ... 1 | 13 | 100 | | 3RV10 11-0JA1 <input type="checkbox"/> | 1 | 1 unit | 101 | 0.249 |
| 1.25 | 0.37 | 0.9 ... 1.25 | 16 | 100 | | 3RV10 11-0KA1 <input type="checkbox"/> | 1 | 1 unit | 101 | 0.297 |
| 1.6 | 0.55 | 1.1 ... 1.6 | 21 | 100 | | 3RV10 11-1AA1 <input type="checkbox"/> | 1 | 1 unit | 101 | 0.298 |
| 2 | 0.75 | 1.4 ... 2 | 26 | 100 | | 3RV10 11-1BA1 <input type="checkbox"/> | 1 | 1 unit | 101 | 0.297 |
| 2.5 | 0.75 | 1.8 ... 2.5 | 33 | 100 | | 3RV10 11-1CA1 <input type="checkbox"/> | 1 | 1 unit | 101 | 0.298 |
| 3.2 | 1.1 | 2.2 ... 3.2 | 42 | 100 | | 3RV10 11-1DA1 <input type="checkbox"/> | 1 | 1 unit | 101 | 0.299 |
| 4 | 1.5 | 2.8 ... 4 | 52 | 100 | | 3RV10 11-1EA1 <input type="checkbox"/> | 1 | 1 unit | 101 | 0.296 |
| 5 | 1.5 | 3.5 ... 5 | 65 | 100 | | 3RV10 11-1FA1 <input type="checkbox"/> | 1 | 1 unit | 101 | 0.301 |
| 6.3 | 2.2 | 4.5 ... 6.3 | 82 | 100 | | 3RV10 11-1GA1 <input type="checkbox"/> | 1 | 1 unit | 101 | 0.303 |
| 8 | 3 | 5.5 ... 8 | 104 | 50 | | 3RV10 11-1HA1 <input type="checkbox"/> | 1 | 1 unit | 101 | 0.304 |
| 10 | 4 | 7 ... 10 | 130 | 50 | | 3RV10 11-1JA1 <input type="checkbox"/> | 1 | 1 unit | 101 | 0.300 |
| 12 | 5.5 | 9 ... 12 | 156 | 50 | | 3RV10 11-1KA1 <input type="checkbox"/> | 1 | 1 unit | 101 | 0.297 |

Size S0



| | | | | | | | | | | |
|------|------|---------------|-----|-----|--|--|---|--------|-----|-------|
| 0.16 | 0.04 | 0.11 ... 0.16 | 2.1 | 100 | | 3RV10 21-0AA1 <input type="checkbox"/> | 1 | 1 unit | 101 | 0.300 |
| 0.2 | 0.06 | 0.14 ... 0.2 | 2.6 | 100 | | 3RV10 21-0BA1 <input type="checkbox"/> | 1 | 1 unit | 101 | 0.304 |
| 0.25 | 0.06 | 0.18 ... 0.25 | 3.3 | 100 | | 3RV10 21-0CA1 <input type="checkbox"/> | 1 | 1 unit | 101 | 0.302 |
| 0.32 | 0.09 | 0.22 ... 0.32 | 4.2 | 100 | | 3RV10 21-0DA1 <input type="checkbox"/> | 1 | 1 unit | 101 | 0.303 |
| 0.4 | 0.09 | 0.28 ... 0.4 | 5.2 | 100 | | 3RV10 21-0EA1 <input type="checkbox"/> | 1 | 1 unit | 101 | 0.303 |
| 0.5 | 0.12 | 0.35 ... 0.5 | 6.5 | 100 | | 3RV10 21-0FA1 <input type="checkbox"/> | 1 | 1 unit | 101 | 0.304 |
| 0.63 | 0.18 | 0.45 ... 0.63 | 8.2 | 100 | | 3RV10 21-0GA1 <input type="checkbox"/> | 1 | 1 unit | 101 | 0.305 |
| 0.8 | 0.18 | 0.55 ... 0.8 | 10 | 100 | | 3RV10 21-0HA1 <input type="checkbox"/> | 1 | 1 unit | 101 | 0.370 |
| 1 | 0.25 | 0.7 ... 1 | 13 | 100 | | 3RV10 21-0JA1 <input type="checkbox"/> | 1 | 1 unit | 101 | 0.368 |
| 1.25 | 0.37 | 0.9 ... 1.25 | 16 | 100 | | 3RV10 21-0KA1 <input type="checkbox"/> | 1 | 1 unit | 101 | 0.369 |
| 1.6 | 0.55 | 1.1 ... 1.6 | 21 | 100 | | 3RV10 21-1AA1 <input type="checkbox"/> | 1 | 1 unit | 101 | 0.371 |
| 2 | 0.75 | 1.4 ... 2 | 26 | 100 | | 3RV10 21-1BA1 <input type="checkbox"/> | 1 | 1 unit | 101 | 0.371 |
| 2.5 | 0.75 | 1.8 ... 2.5 | 33 | 100 | | 3RV10 21-1CA1 <input type="checkbox"/> | 1 | 1 unit | 101 | 0.372 |
| 3.2 | 1.1 | 2.2 ... 3.2 | 42 | 100 | | 3RV10 21-1DA1 <input type="checkbox"/> | 1 | 1 unit | 101 | 0.375 |
| 4 | 1.5 | 2.8 ... 4 | 52 | 100 | | 3RV10 21-1EA1 <input type="checkbox"/> | 1 | 1 unit | 101 | 0.370 |
| 5 | 1.5 | 3.5 ... 5 | 65 | 100 | | 3RV10 21-1FA1 <input type="checkbox"/> | 1 | 1 unit | 101 | 0.376 |
| 6.3 | 2.2 | 4.5 ... 6.3 | 82 | 100 | | 3RV10 21-1GA1 <input type="checkbox"/> | 1 | 1 unit | 101 | 0.374 |
| 8 | 3 | 5.5 ... 8 | 104 | 100 | | 3RV10 21-1HA1 <input type="checkbox"/> | 1 | 1 unit | 101 | 0.374 |
| 10 | 4 | 7 ... 10 | 130 | 100 | | 3RV10 21-1JA1 <input type="checkbox"/> | 1 | 1 unit | 101 | 0.375 |
| 12.5 | 5.5 | 9 ... 12.5 | 163 | 100 | | 3RV10 21-1KA1 <input type="checkbox"/> | 1 | 1 unit | 101 | 0.374 |
| 16 | 7.5 | 11 ... 16 | 208 | 50 | | 3RV10 21-4AA1 <input type="checkbox"/> | 1 | 1 unit | 101 | 0.382 |
| 20 | 7.5 | 14 ... 20 | 260 | 50 | | 3RV10 21-4BA1 <input type="checkbox"/> | 1 | 1 unit | 101 | 0.376 |
| 22 | 11 | 17 ... 22 | 286 | 50 | | 3RV10 21-4CA1 <input type="checkbox"/> | 1 | 1 unit | 101 | 0.378 |
| 25 | 11 | 20 ... 25 | 325 | 50 | | 3RV10 21-4DA1 <input type="checkbox"/> | 1 | 1 unit | 101 | 0.382 |

Order No. supplement for transverse auxiliary switches

None
1 NO + 1 NC

| | Additional price ³⁾ |
|---|--------------------------------|
| 0 | None |
| 5 | X |

1) Standard value for 4-pole standard motors at 50 Hz 400 V AC. The actual starting and rated data of the motor to be protected must be considered when selecting the units.

2) Weights are specified for variants with auxiliary switch.

3) Totals are rounded up and down. This may lead to slight differences in the overall price.

Auxiliary switches can also be ordered separately (see "Mountable Accessories").

Multi-unit/reusable packaging, see "Appendix" --> "Ordering Notes".

* You can order this quantity or a multiple thereof.

3RV Motor Starter Protectors up to 100 A

For motor protection

Class 10, without/with auxiliary switches

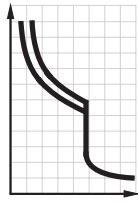

| Rated current I_n | Suitable for three-phase induction motors ¹⁾ with P | Setting range for thermal overload release | Instantaneous overcurrent release | Short-circuit breaking capacity at 400 V AC | DT | Cage Clamp connection | PU (UNIT, SET, M) | PS* | PG | Weight per PU approx. ²⁾ |
|------------------------|--|--|-----------------------------------|---|----|-----------------------|-------------------|-----|----|-------------------------------------|
| A | kW | A | A | kA | | Order No. | Price per PU | | | kg |

Size S00



| | | | | | | | | | | |
|------|------|---------------|-----|-----|--|------------------------|---|--------|-----|-------|
| 0.16 | 0.04 | 0.11 ... 0.16 | 2.1 | 100 | | 3RV10 11-0AA2 □ | 1 | 1 unit | 101 | 0.245 |
| 0.2 | 0.06 | 0.14 ... 0.2 | 2.6 | 100 | | 3RV10 11-0BA2 □ | 1 | 1 unit | 101 | 0.245 |
| 0.25 | 0.06 | 0.18 ... 0.25 | 3.3 | 100 | | 3RV10 11-0CA2 □ | 1 | 1 unit | 101 | 0.246 |
| 0.32 | 0.09 | 0.22 ... 0.32 | 4.2 | 100 | | 3RV10 11-0DA2 □ | 1 | 1 unit | 101 | 0.246 |
| 0.4 | 0.09 | 0.28 ... 0.4 | 5.2 | 100 | | 3RV10 11-0EA2 □ | 1 | 1 unit | 101 | 0.250 |
| 0.5 | 0.12 | 0.35 ... 0.5 | 6.5 | 100 | | 3RV10 11-0FA2 □ | 1 | 1 unit | 101 | 0.247 |
| 0.63 | 0.18 | 0.45 ... 0.63 | 8.2 | 100 | | 3RV10 11-0GA2 □ | 1 | 1 unit | 101 | 0.252 |
| 0.8 | 0.18 | 0.55 ... 0.8 | 10 | 100 | | 3RV10 11-0HA2 □ | 1 | 1 unit | 101 | 0.250 |
| 1 | 0.25 | 0.7 ... 1 | 13 | 100 | | 3RV10 11-0JA2 □ | 1 | 1 unit | 101 | 0.249 |
| 1.25 | 0.37 | 0.9 ... 1.25 | 16 | 100 | | 3RV10 11-0KA2 □ | 1 | 1 unit | 101 | 0.297 |
| 1.6 | 0.55 | 1.1 ... 1.6 | 21 | 100 | | 3RV10 11-1AA2 □ | 1 | 1 unit | 101 | 0.298 |
| 2 | 0.75 | 1.4 ... 2 | 26 | 100 | | 3RV10 11-1BA2 □ | 1 | 1 unit | 101 | 0.297 |
| 2.5 | 0.75 | 1.8 ... 2.5 | 33 | 100 | | 3RV10 11-1CA2 □ | 1 | 1 unit | 101 | 0.298 |
| 3.2 | 1.1 | 2.2 ... 3.2 | 42 | 100 | | 3RV10 11-1DA2 □ | 1 | 1 unit | 101 | 0.300 |
| 4 | 1.5 | 2.8 ... 4 | 52 | 100 | | 3RV10 11-1EA2 □ | 1 | 1 unit | 101 | 0.298 |
| 5 | 1.5 | 3.5 ... 5 | 65 | 100 | | 3RV10 11-1FA2 □ | 1 | 1 unit | 101 | 0.303 |
| 6.3 | 2.2 | 4.5 ... 6.3 | 82 | 100 | | 3RV10 11-1GA2 □ | 1 | 1 unit | 101 | 0.303 |
| 8 | 3 | 5.5 ... 8 | 104 | 50 | | 3RV10 11-1HA2 □ | 1 | 1 unit | 101 | 0.304 |
| 10 | 4 | 7 ... 10 | 130 | 50 | | 3RV10 11-1JA2 □ | 1 | 1 unit | 101 | 0.300 |
| 12 | 5.5 | 9 ... 12 | 156 | 50 | | 3RV10 11-1KA2 □ | 1 | 1 unit | 101 | 0.298 |

Order No. supplement for transverse auxiliary switches

None
1 NO + 1 NC

▶
B

Additional price³⁾

0 None
5 X

1) Standard value for 4-pole standard motors at 50 Hz 400 V AC. The actual starting and rated data of the motor to be protected must be considered when selecting the units.

2) Weights are specified for variants with auxiliary switch.

3) Totals are rounded up and down. This may lead to slight differences in the overall price.

Auxiliary switches can also be ordered separately (see "Mountable Accessories").

Multi-unit/reusable packaging, see "Appendix" --> "Ordering Notes".

3RV Motor Starter Protectors up to 100 A

For motor protection

Class 10, without auxiliary switches

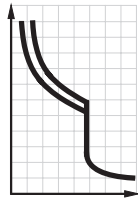

| Rated current | Suitable for three-phase induction motors ¹⁾ with P | Setting range for thermal overload release | Instantaneous overcurrent release | Short-circuit breaking capacity at 400 V AC | DT | Screw connection | PU (UNIT, SET, M) | PS* | PG | Weight per PU approx. |
|---------------|--|--|-----------------------------------|---|----|------------------|-------------------|-----|----|-----------------------|
| I_n | | | | I_{cu} | | Order No. | Price per PU | | | kg |
| A | kW | A | A | kA | | | | | | |

Size S2



| | | | | | | | | | | |
|----|------|-----------|-----|----|---|-----------------------|---|--------|-----|-------|
| 16 | 7.5 | 11 ... 16 | 208 | 50 | ▶ | 3RV10 31-4AA10 | 1 | 1 unit | 101 | 1.046 |
| 20 | 7.5 | 14 ... 20 | 260 | 50 | ▶ | 3RV10 31-4BA10 | 1 | 1 unit | 101 | 1.043 |
| 25 | 11 | 18 ... 25 | 325 | 50 | ▶ | 3RV10 31-4DA10 | 1 | 1 unit | 101 | 1.031 |
| 32 | 15 | 22 ... 32 | 416 | 50 | ▶ | 3RV10 31-4EA10 | 1 | 1 unit | 101 | 1.028 |
| 40 | 18.5 | 28 ... 40 | 520 | 50 | ▶ | 3RV10 31-4FA10 | 1 | 1 unit | 101 | 1.047 |
| 45 | 22 | 36 ... 45 | 585 | 50 | ▶ | 3RV10 31-4GA10 | 1 | 1 unit | 101 | 1.039 |
| 50 | 22 | 40 ... 50 | 650 | 50 | ▶ | 3RV10 31-4HA10 | 1 | 1 unit | 101 | 1.027 |

Size S3



| | | | | | | | | | | |
|-----|------|------------|------|----|---|-----------------------|---|--------|-----|-------|
| 40 | 18.5 | 28 ... 40 | 520 | 50 | ▶ | 3RV10 41-4FA10 | 1 | 1 unit | 101 | 2.219 |
| 50 | 22 | 36 ... 50 | 650 | 50 | ▶ | 3RV10 41-4HA10 | 1 | 1 unit | 101 | 2.240 |
| 63 | 30 | 45 ... 63 | 819 | 50 | ▶ | 3RV10 41-4JA10 | 1 | 1 unit | 101 | 2.247 |
| 75 | 37 | 57 ... 75 | 975 | 50 | ▶ | 3RV10 41-4KA10 | 1 | 1 unit | 101 | 2.253 |
| 90 | 45 | 70 ... 90 | 1170 | 50 | ▶ | 3RV10 41-4LA10 | 1 | 1 unit | 101 | 2.280 |
| 100 | 45 | 80 ... 100 | 1235 | 50 | ▶ | 3RV10 41-4MA10 | 1 | 1 unit | 101 | 2.295 |

Size S3, with increased switching capacity



| | | | | | | | | | | |
|-----|------|------------|------|-----|---|-----------------------|---|--------|-----|-------|
| 16 | 7.5 | 11 ... 16 | 208 | 100 | ▶ | 3RV10 42-4AA10 | 1 | 1 unit | 101 | 2.174 |
| 20 | 7.5 | 14 ... 20 | 260 | 100 | ▶ | 3RV10 42-4BA10 | 1 | 1 unit | 101 | 2.185 |
| 25 | 11 | 18 ... 25 | 325 | 100 | ▶ | 3RV10 42-4DA10 | 1 | 1 unit | 101 | 2.211 |
| 32 | 15 | 22 ... 32 | 416 | 100 | ▶ | 3RV10 42-4EA10 | 1 | 1 unit | 101 | 2.222 |
| 40 | 18.5 | 28 ... 40 | 520 | 100 | ▶ | 3RV10 42-4FA10 | 1 | 1 unit | 101 | 2.203 |
| 50 | 22 | 36 ... 50 | 650 | 100 | ▶ | 3RV10 42-4HA10 | 1 | 1 unit | 101 | 2.230 |
| 63 | 30 | 45 ... 63 | 819 | 100 | ▶ | 3RV10 42-4JA10 | 1 | 1 unit | 101 | 2.255 |
| 75 | 37 | 57 ... 75 | 975 | 100 | ▶ | 3RV10 42-4KA10 | 1 | 1 unit | 101 | 2.266 |
| 90 | 45 | 70 ... 90 | 1170 | 100 | ▶ | 3RV10 42-4LA10 | 1 | 1 unit | 101 | 2.268 |
| 100 | 45 | 80 ... 100 | 1235 | 100 | ▶ | 3RV10 42-4MA10 | 1 | 1 unit | 101 | 2.275 |

Class 20, without auxiliary switches

Size S2



| | | | | | | | | | | |
|----|------|-----------|-----|----|---|-----------------------|---|--------|-----|-------|
| 16 | 7.5 | 11 ... 16 | 208 | 50 | A | 3RV10 31-4AB10 | 1 | 1 unit | 101 | 1.067 |
| 20 | 7.5 | 14 ... 20 | 260 | 50 | A | 3RV10 31-4BB10 | 1 | 1 unit | 101 | 1.071 |
| 25 | 11 | 18 ... 25 | 325 | 50 | A | 3RV10 31-4DB10 | 1 | 1 unit | 101 | 1.054 |
| 32 | 15 | 22 ... 32 | 416 | 50 | A | 3RV10 31-4EB10 | 1 | 1 unit | 101 | 1.067 |
| 40 | 18.5 | 28 ... 40 | 520 | 50 | A | 3RV10 31-4FB10 | 1 | 1 unit | 101 | 1.076 |
| 45 | 22 | 36 ... 45 | 585 | 50 | A | 3RV10 31-4GB10 | 1 | 1 unit | 101 | 1.073 |
| 50 | 22 | 40 ... 50 | 650 | 50 | A | 3RV10 31-4HB10 | 1 | 1 unit | 101 | 1.071 |

Size S3, with increased switching capacity



| | | | | | | | | | | |
|-----|------|------------|-------|-----|---|-----------------------|---|--------|-----|-------|
| 40 | 18.5 | 28 ... 40 | 520 | 100 | A | 3RV10 42-4FB10 | 1 | 1 unit | 101 | 2.222 |
| 50 | 22 | 36 ... 50 | 650 | 100 | A | 3RV10 42-4HB10 | 1 | 1 unit | 101 | 2.265 |
| 63 | 30 | 45 ... 63 | 819 | 100 | A | 3RV10 42-4JB10 | 1 | 1 unit | 101 | 2.278 |
| 75 | 37 | 57 ... 75 | 975 | 100 | A | 3RV10 42-4KB10 | 1 | 1 unit | 101 | 2.268 |
| 90 | 45 | 70 ... 90 | 1.170 | 100 | A | 3RV10 42-4LB10 | 1 | 1 unit | 101 | 2.313 |
| 100 | 45 | 80 ... 100 | 1.235 | 100 | A | 3RV10 42-4MB10 | 1 | 1 unit | 101 | 2.322 |

1) Standard value for 4-pole standard motors at 50 Hz 400 V AC. The actual starting and rated data of the motor to be protected must be considered when selecting the units.

Auxiliary switches can be ordered separately (see "Mountable Accessories").

Multi-unit/reusable packaging, see "Appendix" --> "Ordering Notes".

3RV Motor Starter Protectors up to 100 A

For motor protection with overload relay function

Selection and ordering data

CLASS 10, with overload relay functions (automatic reset), without auxiliary switches

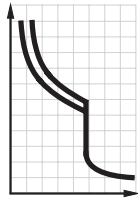

| Rated current | Suitable for three-phase induction motors ¹⁾ with P | Setting range for thermal overload release | Instantaneous over-current release | Short-circuit breaking capacity at 400 V AC | DT | Screw connection | PU (UNIT, SET, M) | PS* | PG | Weight per PU approx. |
|---------------|--|--|------------------------------------|---|----|------------------|-------------------|-----|----|-----------------------|
| I_n | | | $I >$ | I_{cu} | | Order No. | Price per PU | | | kg |
| A | kW | A | A | kA | | | | | | |

Size S0²⁾



| | | | | | | | | | | |
|------|------|---------------|-----|-----|---|-----------------------|---|--------|-----|-------|
| 0.16 | 0.04 | 0.11 ... 0.16 | 2.1 | 100 | A | 3RV11 21-0AA10 | 1 | 1 unit | 101 | 0.354 |
| 0.2 | 0.06 | 0.14 ... 0.2 | 2.6 | 100 | A | 3RV11 21-0BA10 | 1 | 1 unit | 101 | 0.358 |
| 0.25 | 0.06 | 0.18 ... 0.25 | 3.3 | 100 | A | 3RV11 21-0CA10 | 1 | 1 unit | 101 | 0.352 |
| 0.32 | 0.09 | 0.22 ... 0.32 | 4.2 | 100 | A | 3RV11 21-0DA10 | 1 | 1 unit | 101 | 0.352 |
| 0.4 | 0.09 | 0.28 ... 0.4 | 5.2 | 100 | A | 3RV11 21-0EA10 | 1 | 1 unit | 101 | 0.355 |
| 0.5 | 0.12 | 0.35 ... 0.5 | 6.5 | 100 | A | 3RV11 21-0FA10 | 1 | 1 unit | 101 | 0.356 |
| 0.63 | 0.18 | 0.45 ... 0.63 | 8.2 | 100 | A | 3RV11 21-0GA10 | 1 | 1 unit | 101 | 0.358 |
| 0.8 | 0.18 | 0.55 ... 0.8 | 10 | 100 | A | 3RV11 21-0HA10 | 1 | 1 unit | 101 | 0.421 |
| 1 | 0.25 | 0.7 ... 1 | 13 | 100 | A | 3RV11 21-0JA10 | 1 | 1 unit | 101 | 0.416 |
| 1.25 | 0.37 | 0.9 ... 1.25 | 16 | 100 | A | 3RV11 21-0KA10 | 1 | 1 unit | 101 | 0.426 |
| 1.6 | 0.55 | 1.1 ... 1.6 | 21 | 100 | A | 3RV11 21-1AA10 | 1 | 1 unit | 101 | 0.422 |
| 2 | 0.75 | 1.4 ... 2 | 26 | 100 | A | 3RV11 21-1BA10 | 1 | 1 unit | 101 | 0.427 |
| 2.5 | 0.75 | 1.8 ... 2.5 | 33 | 100 | A | 3RV11 21-1CA10 | 1 | 1 unit | 101 | 0.422 |
| 3.2 | 1.1 | 2.2 ... 3.2 | 42 | 100 | A | 3RV11 21-1DA10 | 1 | 1 unit | 101 | 0.428 |
| 4 | 1.5 | 2.8 ... 4 | 52 | 100 | A | 3RV11 21-1EA10 | 1 | 1 unit | 101 | 0.420 |
| 5 | 1.5 | 3.5 ... 5 | 65 | 100 | A | 3RV11 21-1FA10 | 1 | 1 unit | 101 | 0.429 |
| 6.3 | 2.2 | 4.5 ... 6.3 | 82 | 100 | A | 3RV11 21-1GA10 | 1 | 1 unit | 101 | 0.426 |
| 8 | 3 | 5.5 ... 8 | 104 | 100 | A | 3RV11 21-1HA10 | 1 | 1 unit | 101 | 0.425 |
| 10 | 4 | 7 ... 10 | 130 | 100 | A | 3RV11 21-1JA10 | 1 | 1 unit | 101 | 0.428 |
| 12.5 | 5.5 | 9 ... 12.5 | 163 | 100 | A | 3RV11 21-1KA10 | 1 | 1 unit | 101 | 0.426 |
| 16 | 7.5 | 11 ... 16 | 208 | 50 | A | 3RV11 21-4AA10 | 1 | 1 unit | 101 | 0.436 |
| 20 | 7.5 | 14 ... 20 | 260 | 50 | A | 3RV11 21-4BA10 | 1 | 1 unit | 101 | 0.430 |
| 22 | 11 | 17 ... 22 | 286 | 50 | A | 3RV11 21-4CA10 | 1 | 1 unit | 101 | 0.427 |
| 25 | 11 | 20 ... 25 | 325 | 50 | A | 3RV11 21-4DA10 | 1 | 1 unit | 101 | 0.432 |

Size S2²⁾



| | | | | | | | | | | |
|----|------|-----------|-----|----|---|-----------------------|---|--------|-----|-------|
| 16 | 7.5 | 11 ... 16 | 208 | 50 | A | 3RV11 31-4AA10 | 1 | 1 unit | 101 | 1.123 |
| 20 | 7.5 | 14 ... 20 | 260 | 50 | A | 3RV11 31-4BA10 | 1 | 1 unit | 101 | 1.109 |
| 25 | 11 | 18 ... 25 | 325 | 50 | A | 3RV11 31-4DA10 | 1 | 1 unit | 101 | 1.114 |
| 32 | 15 | 22 ... 32 | 416 | 50 | A | 3RV11 31-4EA10 | 1 | 1 unit | 101 | 1.111 |
| 40 | 18.5 | 28 ... 40 | 520 | 50 | A | 3RV11 31-4FA10 | 1 | 1 unit | 101 | 1.123 |
| 45 | 22 | 36 ... 45 | 585 | 50 | A | 3RV11 31-4GA10 | 1 | 1 unit | 101 | 1.101 |
| 50 | 22 | 40 ... 50 | 650 | 50 | A | 3RV11 31-4HA10 | 1 | 1 unit | 101 | 1.106 |

Size S3, with increased switching capacity²⁾



| | | | | | | | | | | |
|-----|------|------------|------|-----|---|-----------------------|---|--------|-----|-------|
| 16 | 7.5 | 11 ... 16 | 208 | 100 | A | 3RV11 42-4AA10 | 1 | 1 unit | 101 | 2.247 |
| 20 | 7.5 | 14 ... 20 | 260 | 100 | A | 3RV11 42-4BA10 | 1 | 1 unit | 101 | 2.255 |
| 25 | 11 | 18 ... 25 | 325 | 100 | A | 3RV11 42-4DA10 | 1 | 1 unit | 101 | 2.284 |
| 32 | 15 | 22 ... 32 | 416 | 100 | A | 3RV11 42-4EA10 | 1 | 1 unit | 101 | 2.295 |
| 40 | 18.5 | 28 ... 40 | 520 | 100 | A | 3RV11 42-4FA10 | 1 | 1 unit | 101 | 2.288 |
| 50 | 22 | 36 ... 50 | 650 | 100 | A | 3RV11 42-4HA10 | 1 | 1 unit | 101 | 2.320 |
| 63 | 30 | 45 ... 63 | 819 | 100 | A | 3RV11 42-4JA10 | 1 | 1 unit | 101 | 2.333 |
| 75 | 37 | 57 ... 75 | 975 | 100 | A | 3RV11 42-4KA10 | 1 | 1 unit | 101 | 2.368 |
| 90 | 45 | 70 ... 90 | 1170 | 100 | A | 3RV11 42-4LA10 | 1 | 1 unit | 101 | 2.353 |
| 100 | 45 | 80 ... 100 | 1235 | 100 | A | 3RV11 42-4MA10 | 1 | 1 unit | 101 | 2.346 |

1) Standard value for 4-pole standard motors at 50 Hz 400 V AC. The actual starting and rated data of the motor to be protected must be considered when selecting the units.

2) Accessories for mounting on the right (for series S0 to S3) and 3RV19 15 three-phase busbars (for size S0) cannot be used.

Auxiliary switches can be ordered separately (see "Mountable accessories").

Multi-unit/reusable packaging, see "Appendix" --> "Ordering Notes".





* You can order this quantity or a multiple thereof.

3RV Motor Starter Protectors up to 100 A

For starter combinations

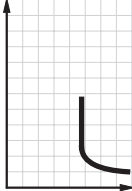
Selection and ordering data

Without auxiliary switches

|  | Rated current | Suitable for three-phase induction motors ¹⁾ with P | Setting range for thermal overload release ²⁾ | Instantaneous over-current release | Short-circuit breaking capacity at 400 V AC | DT | Screw connection | PU (UNIT, SET, M) | PS* | PG | Weight per PU approx. | | |
|---|---|--|--|------------------------------------|---|-----------------------|-----------------------|-----------------------|--------------|--------|-----------------------|-------|--|
| | I_n | kW | A | A | A | kA | | Order No. | Price per PU | | | kg | |
| Size S0 | | | | | | | | | | | | | |
|  | 0.16 | 0.04 | None | 2.1 | 100 | A | 3RV13 21-0AC10 | 1 | 1 unit | 101 | 0.282 | | |
| | 0.2 | 0.06 | None | 2.6 | 100 | A | 3RV13 21-0BC10 | 1 | 1 unit | 101 | 0.284 | | |
| | 0.25 | 0.06 | None | 3.3 | 100 | A | 3RV13 21-0CC10 | 1 | 1 unit | 101 | 0.285 | | |
| | 0.32 | 0.09 | None | 4.2 | 100 | A | 3RV13 21-0DC10 | 1 | 1 unit | 101 | 0.282 | | |
| | 0.4 | 0.09 | None | 5.2 | 100 | A | 3RV13 21-0EC10 | 1 | 1 unit | 101 | 0.286 | | |
| | 0.5 | 0.12 | None | 6.5 | 100 | A | 3RV13 21-0FC10 | 1 | 1 unit | 101 | 0.283 | | |
| | 0.63 | 0.18 | None | 8.2 | 100 | A | 3RV13 21-0GC10 | 1 | 1 unit | 101 | 0.348 | | |
| | 0.8 | 0.18 | None | 10 | 100 | A | 3RV13 21-0HC10 | 1 | 1 unit | 101 | 0.283 | | |
| | 1 | 0.25 | None | 13 | 100 | A | 3RV13 21-0JC10 | 1 | 1 unit | 101 | 0.345 | | |
| | 1.25 | 0.37 | None | 16 | 100 | A | 3RV13 21-0KC10 | 1 | 1 unit | 101 | 0.351 | | |
| | 1.6 | 0.55 | None | 21 | 100 | A | 3RV13 21-1AC10 | 1 | 1 unit | 101 | 0.352 | | |
| | 2 | 0.75 | None | 26 | 100 | A | 3RV13 21-1BC10 | 1 | 1 unit | 101 | 0.352 | | |
| | 2.5 | 0.75 | None | 33 | 100 | A | 3RV13 21-1CC10 | 1 | 1 unit | 101 | 0.352 | | |
| | 3.2 | 1.1 | None | 42 | 100 | A | 3RV13 21-1DC10 | 1 | 1 unit | 101 | 0.353 | | |
| | 4 | 1.5 | None | 52 | 100 | A | 3RV13 21-1EC10 | 1 | 1 unit | 101 | 0.349 | | |
| | 5 | 1.5 | None | 65 | 100 | A | 3RV13 21-1FC10 | 1 | 1 unit | 101 | 0.354 | | |
| | 6.3 | 2.2 | None | 82 | 100 | A | 3RV13 21-1GC10 | 1 | 1 unit | 101 | 0.355 | | |
| | 8 | 3 | None | 104 | 100 | A | 3RV13 21-1HC10 | 1 | 1 unit | 101 | 0.354 | | |
| | 10 | 4 | None | 130 | 100 | A | 3RV13 21-1JC10 | 1 | 1 unit | 101 | 0.357 | | |
| | 12.5 | 5.5 | None | 163 | 100 | A | 3RV13 21-1KC10 | 1 | 1 unit | 101 | 0.354 | | |
| 16 | 7.5 | None | 208 | 50 | A | 3RV13 21-4AC10 | 1 | 1 unit | 101 | 0.362 | | | |
| 20 | 7.5 | None | 260 | 50 | A | 3RV13 21-4BC10 | 1 | 1 unit | 101 | 0.357 | | | |
| 22 | 11 | None | 286 | 50 | A | 3RV13 21-4CC10 | 1 | 1 unit | 101 | 0.358 | | | |
| 25 | 11 | None | 325 | 50 | A | 3RV13 21-4DC10 | 1 | 1 unit | 101 | 0.359 | | | |
| Size S2 | | | | | | | | | | | | | |
|  | 16 | 7.5 | None | 208 | 50 | A | 3RV13 31-4AC10 | 1 | 1 unit | 101 | 1.038 | | |
| | 20 | 7.5 | None | 260 | 50 | A | 3RV13 31-4BC10 | 1 | 1 unit | 101 | 1.037 | | |
| | 25 | 11 | None | 325 | 50 | A | 3RV13 31-4DC10 | 1 | 1 unit | 101 | 1.014 | | |
| | 32 | 15 | None | 416 | 50 | A | 3RV13 31-4EC10 | 1 | 1 unit | 101 | 1.018 | | |
| | 40 | 18.5 | None | 520 | 50 | A | 3RV13 31-4FC10 | 1 | 1 unit | 101 | 1.033 | | |
| | 45 | 22 | None | 585 | 50 | A | 3RV13 31-4GC10 | 1 | 1 unit | 101 | 1.040 | | |
| | 50 | 22 | None | 650 | 50 | A | 3RV13 31-4HC10 | 1 | 1 unit | 101 | 1.019 | | |
| | Size S3 | | | | | | | | | | | | |
| |  | 40 | 18.5 | None | 520 | 50 | A | 3RV13 41-4FC10 | 1 | 1 unit | 101 | 2.197 | |
| | | 50 | 22 | None | 650 | 50 | A | 3RV13 41-4HC10 | 1 | 1 unit | 101 | 2.227 | |
| 63 | | 30 | None | 819 | 50 | A | 3RV13 41-4JC10 | 1 | 1 unit | 101 | 2.244 | | |
| 75 | | 37 | None | 975 | 50 | A | 3RV13 41-4KC10 | 1 | 1 unit | 101 | 2.247 | | |
| 90 | | 45 | None | 1170 | 50 | A | 3RV13 41-4LC10 | 1 | 1 unit | 101 | 2.269 | | |
| 100 | | 45 | None | 1235 | 50 | A | 3RV13 41-4MC10 | 1 | 1 unit | 101 | 2.292 | | |
| Size S3, with increased switching capacity | | | | | | | | | | | | | |
|  | 16 | 7.5 | None | 208 | 100 | A | 3RV13 42-4AC10 | 1 | 1 unit | 101 | 2.175 | | |
| | 20 | 7.5 | None | 260 | 100 | A | 3RV13 42-4BC10 | 1 | 1 unit | 101 | 2.188 | | |
| | 25 | 11 | None | 325 | 100 | A | 3RV13 42-4DC10 | 1 | 1 unit | 101 | 2.219 | | |
| | 32 | 15 | None | 416 | 100 | A | 3RV13 42-4EC10 | 1 | 1 unit | 101 | 2.208 | | |
| | 40 | 18.5 | None | 520 | 100 | A | 3RV13 42-4FC10 | 1 | 1 unit | 101 | 2.218 | | |
| | 50 | 22 | None | 650 | 100 | A | 3RV13 42-4HC10 | 1 | 1 unit | 101 | 2.218 | | |
| | 63 | 30 | None | 819 | 100 | A | 3RV13 42-4JC10 | 1 | 1 unit | 101 | 2.248 | | |
| | 75 | 37 | None | 975 | 100 | A | 3RV13 42-4KC10 | 1 | 1 unit | 101 | 2.278 | | |
| | 90 | 45 | None | 1170 | 100 | A | 3RV13 42-4LC10 | 1 | 1 unit | 101 | 2.266 | | |
| | 100 | 45 | None | 1235 | 100 | A | 3RV13 42-4MC10 | 1 | 1 unit | 101 | 2.293 | | |

- Standard value for 4-pole standard motors at 50 Hz 400 V AC. The actual starting and rated data of the motor to be protected must be considered when selecting the units.
- For overload protection of the motors, appropriate overload relays must be used.

Auxiliary switches can be ordered separately (see "Mountable Accessories").

Multi-unit/reusable packaging, see "Appendix" --> "Ordering Notes".

* You can order this quantity or a multiple thereof.

3RV Motor Starter Protectors up to 100 A

For transformer protection

Selection and ordering data

Class 10, without auxiliary switches

Motor starter protectors for the protection of transformers with high inrush current.

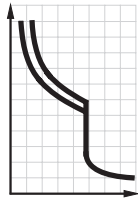

| Rated current I_n | Setting range for thermal overload release | Instantaneous overcurrent release $I >$ | Short-circuit breaking capacity at 400 V AC I_{cu} | DT | Screw connection | PU (UNIT, SET, M) | PS* | PG | Weight per PU approx. | |
|------------------------|--|--|---|-----|-----------------------|-----------------------|--------|--------|-----------------------|-------|
| A | A | A | kA | | Order No. | Price per PU | | | kg | |
| Size S0 | | | | | | | | | | |
| | 0.16 | 0.11 ... 0.16 | 3.3 | 100 | ▶ | 3RV14 21-0AA10 | 1 | 1 unit | 101 | 0.286 |
| | 0.2 | 0.14 ... 0.2 | 4.2 | 100 | ▶ | 3RV14 21-0BA10 | 1 | 1 unit | 101 | 0.287 |
| | 0.25 | 0.18 ... 0.25 | 5.2 | 100 | ▶ | 3RV14 21-0CA10 | 1 | 1 unit | 101 | 0.286 |
| | 0.32 | 0.22 ... 0.32 | 6.5 | 100 | ▶ | 3RV14 21-0DA10 | 1 | 1 unit | 101 | 0.288 |
| | 0.4 | 0.28 ... 0.4 | 8.2 | 100 | ▶ | 3RV14 21-0EA10 | 1 | 1 unit | 101 | 0.287 |
| | 0.5 | 0.35 ... 0.5 | 10 | 100 | ▶ | 3RV14 21-0FA10 | 1 | 1 unit | 101 | 0.286 |
| | 0.63 | 0.45 ... 0.63 | 13 | 100 | ▶ | 3RV14 21-0GA10 | 1 | 1 unit | 101 | 0.290 |
| | 0.8 | 0.55 ... 0.8 | 16 | 100 | ▶ | 3RV14 21-0HA10 | 1 | 1 unit | 101 | 0.290 |
| | 1 | 0.7 ... 1 | 21 | 100 | ▶ | 3RV14 21-0JA10 | 1 | 1 unit | 101 | 0.353 |
| | 1.25 | 0.9 ... 1.25 | 26 | 100 | ▶ | 3RV14 21-0KA10 | 1 | 1 unit | 101 | 0.354 |
| | 1.6 | 1.1 ... 1.6 | 33 | 100 | ▶ | 3RV14 21-1AA10 | 1 | 1 unit | 101 | 0.353 |
| | 2 | 1.4 ... 2 | 42 | 100 | ▶ | 3RV14 21-1BA10 | 1 | 1 unit | 101 | 0.358 |
| | 2.5 | 1.8 ... 2.5 | 52 | 100 | ▶ | 3RV14 21-1CA10 | 1 | 1 unit | 101 | 0.354 |
| | 3.2 | 2.2 ... 3.2 | 65 | 100 | ▶ | 3RV14 21-1DA10 | 1 | 1 unit | 101 | 0.358 |
| | 4 | 2.8 ... 4 | 82 | 100 | ▶ | 3RV14 21-1EA10 | 1 | 1 unit | 101 | 0.354 |
| | 5 | 3.5 ... 5 | 104 | 100 | ▶ | 3RV14 21-1FA10 | 1 | 1 unit | 101 | 0.357 |
| 6.3 | 4.5 ... 6.3 | 130 | 100 | ▶ | 3RV14 21-1GA10 | 1 | 1 unit | 101 | 0.356 | |
| 8 | 5.5 ... 8 | 163 | 100 | ▶ | 3RV14 21-1HA10 | 1 | 1 unit | 101 | 0.358 | |
| 10 | 7 ... 10 | 208 | 100 | ▶ | 3RV14 21-1JA10 | 1 | 1 unit | 101 | 0.362 | |
| 12.5 | 9 ... 12.5 | 260 | 100 | ▶ | 3RV14 21-1KA10 | 1 | 1 unit | 101 | 0.360 | |
| 16 | 11 ... 16 | 286 | 50 | ▶ | 3RV14 21-4AA10 | 1 | 1 unit | 101 | 0.365 | |
| 20 | 14 ... 20 | 325 | 50 | ▶ | 3RV14 21-4BA10 | 1 | 1 unit | 101 | 0.365 | |
| Size S2 | | | | | | | | | | |
| | 16 | 11 ... 16 | 325 | 50 | ▶ | 3RV14 31-4AA10 | 1 | 1 unit | 101 | 1.029 |
| | 20 | 14 ... 20 | 416 | 50 | ▶ | 3RV14 31-4BA10 | 1 | 1 unit | 101 | 1.034 |
| | 25 | 18 ... 25 | 520 | 50 | ▶ | 3RV14 31-4DA10 | 1 | 1 unit | 101 | 1.038 |
| | 32 | 22 ... 32 | 660 | 50 | ▶ | 3RV14 31-4EA10 | 1 | 1 unit | 101 | 1.029 |
| | 40 | 28 ... 40 | 836 | 50 | ▶ | 3RV14 31-4FA10 | 1 | 1 unit | 101 | 1.039 |

Auxiliary switches can be ordered separately (see "Mountable Accessories").

Multi-unit/reusable packaging, see "Appendix" --> "Ordering Notes".

* You can order this quantity or a multiple thereof.

3RV Motor Starter Protectors up to 100 A

For fuse monitoring

Selection and ordering data

Without auxiliary switches

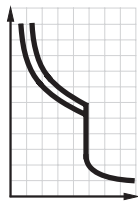

| Rated current I_n A | Thermal overload release | Instantaneous overcurrent release $I >$ A | Short-circuit breaking capacity at 400 V AC I_{cu} kA | DT | Screw connection | PU (UNIT, SET, M) | PS* | PG | Weight per PU approx. kg |
|-----------------------------|------------------------------|---|---|----|------------------|-------------------|-----|----|-----------------------------|
| | | | | | Order No. | Price per PU | | | |

Size S00



| | | | | | | | | | |
|-----|-----|-----|-----|---|-----------------------|---|--------|-----|-------|
| 0.2 | 0.2 | 1.2 | 100 | ▶ | 3RV16 11-0BD10 | 1 | 1 unit | 101 | 0.289 |
|-----|-----|-----|-----|---|-----------------------|---|--------|-----|-------|

Multi-unit/reusable packaging, see "Appendix" --> "Ordering Notes".

The auxiliary switch required for signaling can be ordered separately.

| Type | Version | DT | Order No. | Price per PU | PU (UNIT, SET, M) | PS* | PG | Weight per PU approx. kg |
|------|---------|----|-----------|--------------|-------------------|-----|----|-----------------------------|
|------|---------|----|-----------|--------------|-------------------|-----|----|-----------------------------|

Mountable auxiliary switches



| | | | | | | | |
|---|-------------|---|--------------------|---|--------|-----|-------|
| Transverse auxiliary switches with screw connection | 1 NO + 1 NC | ▶ | 3RV19 01-1E | 1 | 1 unit | 101 | 0.018 |
|---|-------------|---|--------------------|---|--------|-----|-------|



| | | | | | | | |
|--|-------------|---|--------------------|---|--------|-----|-------|
| Lateral auxiliary switches with screw connection | 1 NO + 1 NC | ▶ | 3RV19 01-1A | 1 | 1 unit | 101 | 0.045 |
|--|-------------|---|--------------------|---|--------|-----|-------|

3RV19 01-1A

For further auxiliary switches, see "Mountable accessories".

5

3RV Motor Starter Protectors up to 100 A

For plant protection according to
UL 489 / CSA C22.2 No. 5-02

Selection and ordering data

Class 10, without auxiliary switches

Motor starter protectors for plant protection according to UL/CSA.

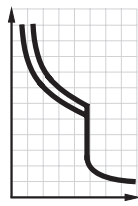

| Rated current | Setting range for thermal overload release (non-adjustable) | Instantaneous overcurrent release | Short-circuit breaking capacity at 400 V AC | DT | Screw connection | PU (UNIT, SET, M) | PS* | PG | Weight per PU approx. |
|---------------|---|-----------------------------------|---|----|------------------|-------------------|-----|----|-----------------------|
| I_n | | $I >$ | I_{cu} | | Order No. | Price per PU | | | kg |
| A | A | A | kA | | | | | | |

Size S3





| | | | | | | | | | |
|----|----|-----|-----|---|-----------------------|---|--------|-----|-------|
| 10 | 10 | 150 | 100 | B | 3RV17 42-5AD10 | 1 | 1 unit | 101 | 2.200 |
| 15 | 15 | 225 | 100 | B | 3RV17 42-5BD10 | 1 | 1 unit | 101 | 2.200 |
| 20 | 20 | 260 | 100 | B | 3RV17 42-5CD10 | 1 | 1 unit | 101 | 2.200 |
| 25 | 25 | 325 | 100 | B | 3RV17 42-5DD10 | 1 | 1 unit | 101 | 2.200 |
| 30 | 30 | 390 | 100 | B | 3RV17 42-5ED10 | 1 | 1 unit | 101 | 2.200 |
| 35 | 35 | 455 | 100 | B | 3RV17 42-5FD10 | 1 | 1 unit | 101 | 2.200 |
| 40 | 40 | 520 | 100 | B | 3RV17 42-5GD10 | 1 | 1 unit | 101 | 2.200 |
| 45 | 45 | 585 | 100 | B | 3RV17 42-5HD10 | 1 | 1 unit | 101 | 2.200 |
| 50 | 50 | 650 | 100 | B | 3RV17 42-5JD10 | 1 | 1 unit | 101 | 2.200 |
| 60 | 60 | 780 | 100 | B | 3RV17 42-5LD10 | 1 | 1 unit | 101 | 2.200 |
| 70 | 70 | 910 | 100 | B | 3RV17 42-5PD10 | 1 | 1 unit | 101 | 2.200 |

3RV Motor Starter Protectors up to 100 A

For distance protection

Selection and ordering data

Voltage transformer circuit-breakers with auxiliary switches

| Rated current | Thermal overload release | Instantaneous overcurrent release | Auxiliary switch integrated in the circuit-breaker, transverse | Short-circuit breaking capacity at 400 V AC | DT | Screw connection | PU (UNIT, SET, M) | PS* | PG | Weight per PU approx. |
|---------------|---|---|--|---|----|------------------|-------------------|-----|----|-----------------------|
| I_n |  |  | | I_{cu} | | Order No. | Price per PU | | | kg |
| A | A | A | | kA | | | | | | |

Size S00



| | | | | | | | | | | |
|-----|-----|------|------|----|---|-----------------------|---|--------|-----|-------|
| 1.4 | 1.4 | 6 | 1 CO | 50 | B | 3RV16 11-1AG14 | 1 | 1 unit | 101 | 0.314 |
| 2.5 | 2.5 | 10.5 | 1 CO | 50 | ▶ | 3RV16 11-1CG14 | 1 | 1 unit | 101 | 0.318 |
| 3 | 3 | 20 | 1 CO | 50 | ▶ | 3RV16 11-1DG14 | 1 | 1 unit | 101 | 0.315 |

| Type | Version | DT | Order No. | Price per PU | PU (UNIT, SET, M) | PS* | PG | Weight per PU approx. |
|------|---------|----|-----------|--------------|-------------------|-----|----|-----------------------|
| | | | | | | | | kg |

Laterally mountable auxiliary switches for other signaling purposes



3RV19 01-1A

| | | | | | | | | |
|----------------------------|-------------|---|--------------------|--|---|--------|-----|-------|
| Lateral auxiliary switches | 1 NO + 1 NC | ▶ | 3RV19 01-1A | | 1 | 1 unit | 101 | 0.045 |
|----------------------------|-------------|---|--------------------|--|---|--------|-----|-------|

For further auxiliary switches, see "Mountable Accessories".

More information

Conversion of voltage transformer circuit-breakers 3VU13 to 3RV1

The 3VU13 voltage transformer circuit-breakers previously available have been discontinued. The 3RV1 voltage transformer circuit-breakers are offered as replacement types.

| Previous type | Replacement type |
|----------------|------------------------------|
| 3VU13 11-6HR00 | 3RV16 11-1CG14 |
| 3VU13 21-6HR00 | 3RV16 11-1CG14 + 3RV19 01-1A |
| 3VU13 11-6JR00 | 3RV16 11-1DG14 |

3RV Motor Starter Protectors up to 100 A

Accessories

Mountable accessories

Overview

Mounting location and function

The 3RV1 motor starter protectors have three main contact elements. In order to achieve maximum flexibility, auxiliary switches, alarm switches, auxiliary releases and isolator modules can be supplied separately.

These components can be fitted as required on the motor starter protectors without using tools.

| | | |
|---|--|---|
| <p>Front</p> <p><u>Notes:</u></p> <ul style="list-style-type: none"> A maximum of 4 auxiliary contacts with auxiliary switches can be attached to each motor starter protector. Transverse auxiliary switches must not be used for the 3RV17 motor starter protectors. | <p>Transverse auxiliary switches</p> <p>1 NO + 1 NC</p> <p>or</p> <p>2 NO</p> <p>or 1 changeover contact</p> | <p>An auxiliary contact block can be inserted transversely on the front. The overall width of the motor starter protectors remains unchanged.</p> |
| <p>Left-hand side</p> <p><u>Notes:</u></p> <ul style="list-style-type: none"> Auxiliary switches (2 contacts) and alarm switches can be mounted separately or together. A maximum of 4 auxiliary contacts with auxiliary switches can be attached to each motor starter protector. | <p>Lateral auxiliary switches (2 contacts)</p> <p>1 NO + 1 NC</p> <p>or</p> <p>2 NO</p> <p>or</p> <p>2 NC</p> | <p>One of the three auxiliary switches can be mounted laterally for each motor starter protector. The contacts of the auxiliary switch close and open together with the main contacts of the motor starter protector.</p> <p>The overall width of the lateral auxiliary switch with 2 contacts is 9 mm.</p> |
| | <p>Lateral auxiliary switches (4 contacts)</p> <p>2 NO + 2 NC</p> | <p>One auxiliary switch can be mounted laterally for each motor starter protector. The contacts of the auxiliary switch close and open together with the main contacts of the motor starter protector.</p> <p>The overall width of the lateral auxiliary switch with 4 contacts is 18 mm.</p> |
| | <p>Alarm switches for sizes S0, S2, and S3</p> <p>Trip 1 NO + 1 NC</p> <p>Short-circuit 1 NO + 1 NC</p> | <p>One alarm switch can be mounted at the side of each motor starter protector with a rotary operating mechanism.</p> <p>The alarm switch has two contact systems.</p> <p>One contact system always signals tripping irrespective of whether this was caused by a short-circuit, an overload or an auxiliary release. The other contact system only switches in the event of a short-circuit. There is no signaling as a result of <u>switching off</u> with the handle.</p> <p>In order to be able to switch on the motor starter protector again after a short-circuit, the alarm switch must be reset manually after the error cause has been eliminated.</p> <p>The overall width of the alarm switch is 18 mm.</p> |
| <p>Right-hand side</p> <p><u>Notes:</u></p> <ul style="list-style-type: none"> One auxiliary release can be mounted per motor starter protector. Accessories cannot be mounted at the right-hand side of the 3RV11 motor starter protectors with overload relay function. | <p>Shunt release</p> <p>or</p> | <p>For remote-controlled tripping of the motor starter protector. The release coil should only be energized for short periods (see schematics).</p> |
| | <p>Undervoltage release</p> <p>or</p> | <p>Trips the motor starter protector when the voltage is interrupted and prevents the motor from being restarted accidentally when the voltage is restored. Used for remote-controlled tripping of the motor starter protector.</p> <p>Particularly suitable for EMERGENCY-STOP disconnection by way of the corresponding EMERGENCY-STOP button according to DIN VDE 0113.</p> |
| | <p>Undervoltage release with leading auxiliary contacts (2 NO)</p> | <p>Function and use as for the undervoltage release without leading auxiliary contacts, but with the following additional function: the auxiliary contacts will open in switch position OFF to deenergize the coil of the undervoltage release, thus interrupting power consumption. In the "tripped" position, these auxiliary contacts are not guaranteed to open. The leading contacts permit the motor starter protector to reclose.</p> <p>The overall width of the auxiliary release is 18 mm.</p> |
| <p>Top</p> <p><u>Note:</u></p> <p>The isolator module covers the terminal screws of the transverse auxiliary switch. If the isolator module is used, we therefore recommend that either the lateral auxiliary switches be fitted or that the isolator module not be mounted until the auxiliary switch has been wired.</p> | <p>Isolator modules for motor starter protectors</p> <p>Size S0 and S2</p> | <p>Isolator modules can be mounted to the upper terminal end of motor starter protectors of sizes S0 and S2.</p> <p>The supply cable is connected to the motor starter protector through the isolator module.</p> <p>The plug can only be unplugged when the motor starter protector is open and isolates all 3 poles of the motor starter protector from the network. The shock-protected isolation point is clearly visible and secured with a padlock to prevent reinsertion of the plug.</p> |

3RV Motor Starter Protectors up to 100 A

Accessories

Mountable accessories

S00 circuit-breakers with mountable accessories

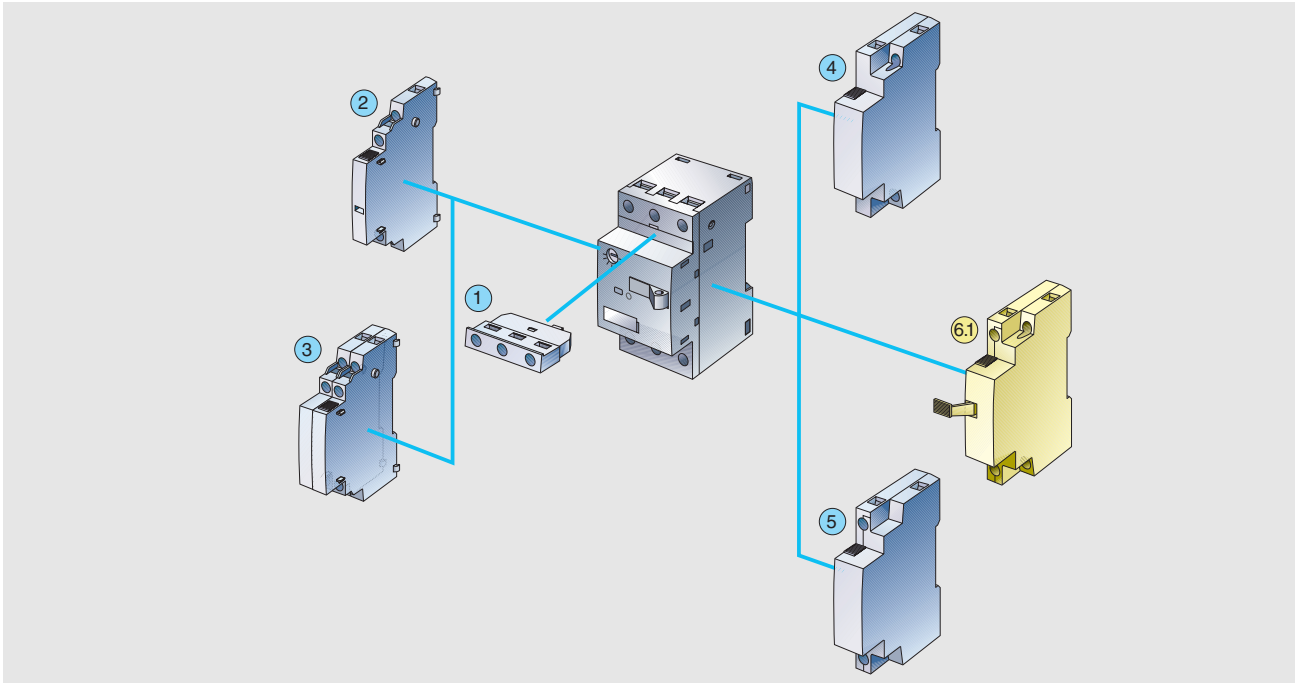

Circuit-breakers, sizes S0, S2 or S3, with mountable accessories

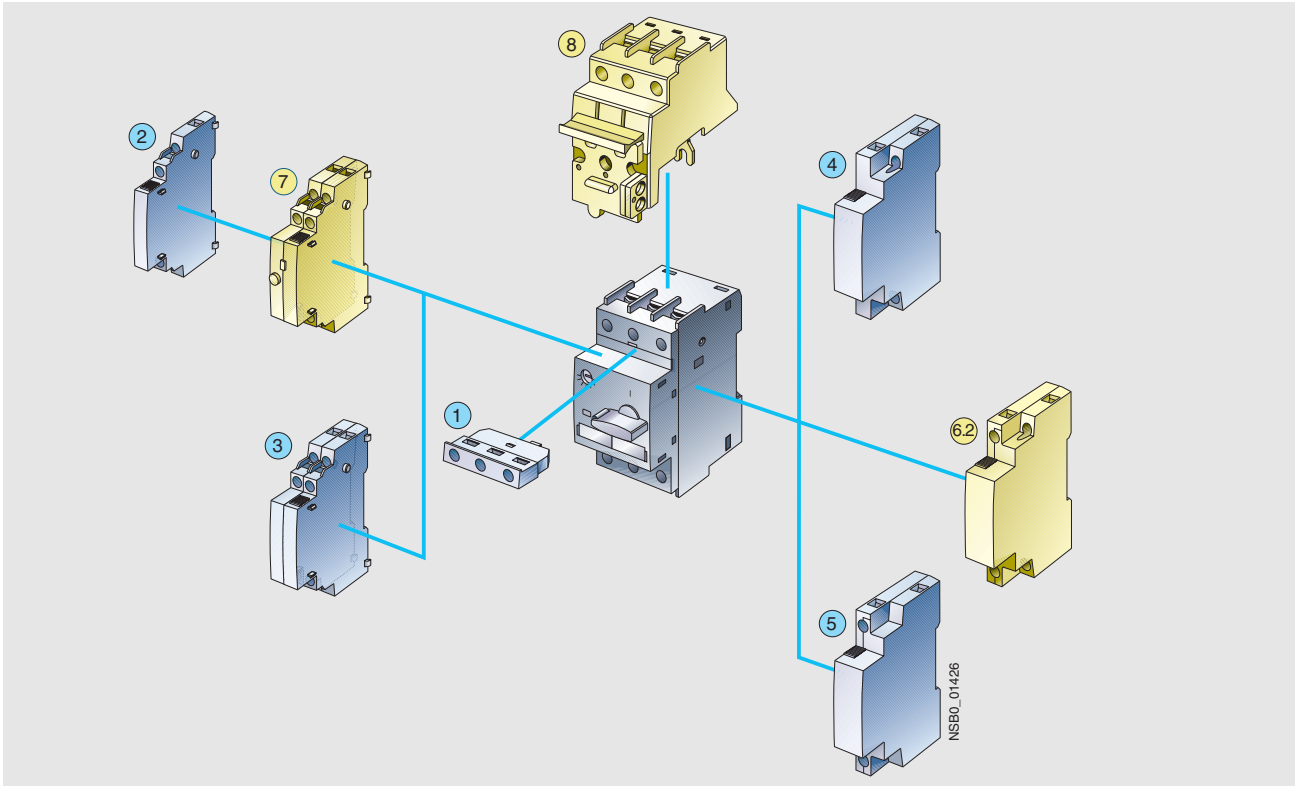

Mountable accessories for all sizes S00 ... S3

- ① Transverse auxiliary switch
- ② Lateral auxiliary switch with 2 contacts
- ③ Lateral auxiliary switch with 4 contacts
- ④ Shunt release
- ⑤ Undervoltage release

Mountable accessories

- ⑥.1 Undervoltage release with leading auxiliary contacts
- ⑥.2 Undervoltage release with leading auxiliary contacts

for sizes

- S00
- S0 ... S3

Mountable accessories for sizes







- ⑦ Signalling switch S0 ... S3
- ⑧ Isolator module S0 and S2

3RV Motor Starter Protectors up to 100 A

Accessories



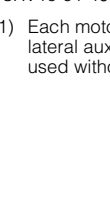

Mountable accessories

Selection and ordering data

| Type | Version | For motor starter protectors Size | DT | Screw connection | PU (UNIT, SET, M) | PS* | PG | Weight per PU approx. | |
|--|---|---|--------------------|--|-------------------|-------------|----------------------------|-----------------------|-------------------------|
| | | | | Order No. | Price per PU | | | kg | |
| Auxiliary switches¹⁾ | | | | | | | | | |
|  3RV19 01-1E | Transverse auxiliary switches with screw connection | 1 CO 1 NO + 1 NC 2 NO ²⁾ | S00, S0, S2, S3 | ▶ 3RV19 01-1D ▶ 3RV19 01-1E ▶ 3RV19 01-1F | | 1 1 1 | 1 unit 1 unit 1 unit | 101 101 101 | 0.015 0.018 0.018 |
|  3RV19 01-1G | Solid-state compatible transverse auxiliary switches with screw connection for use in dusty atmosphere and in solid-state circuits with low operating currents | 1 CO | S00, S0, S2, S3 | 3RV19 01-1G | | 1 | 1 unit | 101 | 0.016 |
|  3RV19 01-0H | Covering caps for transverse auxiliary switches | | S00, S0, S2, S3 | 3RV19 01-0H | | 1 | 10 units | 101 | 0.006 |
|  3RV19 01-1A | Lateral auxiliary switches with screw connection | 1 NO + 1 NC | S00, S0, S2, S3 | ▶ 3RV19 01-1A | | 1 | 1 unit | 101 | 0.045 |
|  3RV19 01-1B | | 2 NO | | ▶ 3RV19 01-1B | | 1 | 1 unit | 101 | 0.045 |
|  3RV19 01-1C | | 2 NC | | ▶ 3RV19 01-1C | | 1 | 1 unit | 101 | 0.045 |
|  3RV19 01-1J | | 2 NO + 2 NC | A | 3RV19 01-1J | | 1 | 1 unit | 101 | 0.083 |

1) Each motor starter protector can be fitted with one transverse and one lateral auxiliary switch. The lateral auxiliary switch with 2 NO + 2 NC is used without a transverse auxiliary switch.

2) Compatible with the following motor starter protectors:
 3RV1. 1 (size S00) as of version E01
 3RV1. 2 (size S0) as of version E04
 3RV1. 3 (size S2) as of version E04
 3RV1. 4 (size S3) as of version E04.



| Type | Version | DT | Order No. | Price per PU | PU (UNIT, SET, M) | PS* | PG | Weight per PU approx. |
|--|--|---------------------|--|--------------|-------------------|------------------|------------|-----------------------|
| | | | | | | | | kg |
| Transverse auxiliary switches with Cage Clamp connection | | | | | | | | |
|  3RV19 01-2E | 1 transverse auxiliary switch can be mounted on each motor starter protector | 1 NO + 1 NC 2 NO | ▶ 3RV19 01-2E ▶ 3RV19 01-2F | | 1 1 | 1 unit 1 unit | 101 101 | 0.017 0.018 |
| Laterally mountable auxiliary switches with Cage Clamp connection | | | | | | | | |
|  3RV19 01-2A | 1 lateral auxiliary switch can be mounted on the left for each motor starter protector | 1 NO + 1 NC | ▶ 3RV19 01-2A | | 1 | 1 unit | 101 | 0.040 |
|  3RV19 01-2B | | 2 NO | ▶ 3RV19 01-2B | | 1 | 1 unit | 101 | 0.040 |
|  3RV19 01-2C | | 2 NC | ▶ 3RV19 01-2C | | 1 | 1 unit | 101 | 0.040 |

* You can order this quantity or a multiple thereof.

3RV Motor Starter Protectors up to 100 A

Accessories

Mountable accessories



| Type | Version | For motor starter protectors Size | DT | Screw connection | PU (UNIT, SET, M) | PS* | PG | Weight per PU approx. | |
|---|-------------------------|--|------------|------------------|--|-----|--------|-----------------------|-------|
| | | | | Order No. | Price per PU | | | kg | |
| Alarm switches¹⁾ | | | | | | | | | |
|  3RV19 21-1M | Alarm switches | Separate tripped and short-circuit alarms, each 1 NO + 1 NC. | S0, S2, S3 | ▶ | 3RV19 21-1M | 1 | 1 unit | 101 | 0.094 |
| | | | | A | | | | | |
| Isolator modules | | | | | | | | | |
|  3RV19 38-1A with padlock | Isolator modules | Visible isolating distance for isolating individual motor starter protectors from the network, lockable in isolating position. | S0 S2 | ▶ | 3RV19 28-1A 3RV19 38-1A | 1 | 1 unit | 101 | 0.157 |
| | | | | A | | | | | |

1) One alarm switch can be mounted to the left of each motor starter protector.

3RV Motor Starter Protectors up to 100 A

Accessories

Mountable accessories

| Rated control supply voltage U_s | | | | | For motor starter protectors Size | DT | Screw connection | PU (UNIT, SET, M) | PS* | PG | Weight per PU approx. | |
|---|-------|----------|--------------|-------------|-----------------------------------|-----------------|------------------|----------------------|-----|--------|-----------------------|-------|
| AC | AC | AC | AC/DC | DC | | | | | | | | |
| 50 Hz | 60 Hz | 50/60 Hz | 50/60 Hz, DC | | | | | | | | | |
| 100% ON-time ¹⁾ | | | | | | | | | | | | |
| 5 s ON-time ²⁾ | | | | | | | | | | | | |
| V | V | V | V | V | | | Order No. | Price per PU | | | kg | |
| Auxiliary releases³⁾ | | | | | | | | | | | | |
| Undervoltage release | | | | | | | | | | | | |
|  | - | - | - | - | 24 | S00, S0, S2, S3 | A | 3RV19 02-1AB4 | 1 | 1 unit | 101 | 0.138 |
| | 24 | - | - | - | - | | A | 3RV19 02-1AB0 | 1 | 1 unit | 101 | 0.134 |
| | 110 | 120 | - | - | - | | A | 3RV19 02-1AF0 | 1 | 1 unit | 101 | 0.134 |
| | - | 208 | - | - | - | | A | 3RV19 02-1AM1 | 1 | 1 unit | 101 | 0.128 |
| | 230 | 240 | - | - | - | | A | 3RV19 02-1AP0 | 1 | 1 unit | 101 | 0.131 |
| | 400 | 440 | - | - | - | | A | 3RV19 02-1AV0 | 1 | 1 unit | 101 | 0.127 |
| | 415 | 480 | - | - | - | | A | 3RV19 02-1AV1 | 1 | 1 unit | 101 | 0.129 |
| | 500 | 575 | - | - | - | | A | 3RV19 02-1AS0 | 1 | 1 unit | 101 | 0.127 |
| 3RV19 02-1DPO | | | | | | | | | | | | |
| Undervoltage release with leading auxiliary contacts 2 NO | | | | | | | | | | | | |
|  | 230 | 240 | - | - | - | S00 | A | 3RV19 12-1CP0 | 1 | 1 unit | 101 | 0.140 |
| | 400 | - | - | - | - | | A | 3RV19 12-1CV0 | 1 | 1 unit | 101 | 0.137 |
| | 415 | 480 | - | - | - | | A | 3RV19 12-1CV1 | 1 | 1 unit | 101 | 0.139 |
| | 230 | 240 | - | - | - | S0, S2, S3 | A | 3RV19 22-1CP0 | 1 | 1 unit | 101 | 0.139 |
| | 400 | - | - | - | - | | A | 3RV19 22-1CV0 | 1 | 1 unit | 101 | 0.136 |
| | 415 | 480 | - | - | - | | A | 3RV19 22-1CV1 | 1 | 1 unit | 101 | 0.138 |
| 3RV19 12-1CP0 | | | | | | | | | | | | |
| Shunt releases | | | | | | | | | | | | |
| | - | - | 20 ... 24 | 20 ... 70 | - | S00, S0, S2, S3 | A | 3RV19 02-1DB0 | 1 | 1 unit | 101 | 0.133 |
| | - | - | 90 ... 110 | 70 ... 190 | - | | A | 3RV19 02-1DF0 | 1 | 1 unit | 101 | 0.135 |
| | - | - | 210 ... 240 | 190 ... 330 | - | | A | 3RV19 02-1DP0 | 1 | 1 unit | 101 | 0.130 |
| | - | - | 350 ... 415 | 330 ... 500 | - | | A | 3RV19 02-1DV0 | 1 | 1 unit | 101 | 0.129 |
| | - | - | 500 | 500 | - | | A | 3RV19 02-1DS0 | 1 | 1 unit | 101 | 0.126 |

- 1) The voltage range is valid for 100 % (infinite) ON-time. The response voltage is at 0.9 the lower limit of the voltage range.
- 2) The voltage range is valid for 5 s ON-time at AC 50 Hz/60 Hz and DC. The response voltage is at 0.85 the lower limit of the voltage range.
- 3) One auxiliary release can be mounted to the right of each motor starter protector.

Overview

Insulated three-phase busbar systems

Three-phase busbar systems provide an easy, time-saving and clearly arranged means of feeding 3RV1 motor starter protectors with screw-type terminals. Different designs are available for sizes S00, S0 and S2 and can be used for the various different types of motor starter protectors. The only exceptions are the 3RV19 15 three-phase busbar systems, which are not suitable for the 3RV11 three-phase busbar systems with overload relay function.

The busbars are suitable for between 2 and 5 motor starter protectors. However, any kind of extension is possible by clamping the tags of an additional busbar (rotated by 180°) underneath the terminals of the respective last motor starter protector.

Different sized motor starter protectors cannot be clamped together due to the different dimensions. Special connectors are available for connecting three-phase busbars for S0 motor starter protectors to busbars for S00 motor starter protectors.

Busbars with larger modular spacing can be used for motor starter protectors with laterally mounted accessories.

The motor starter protectors are supplied by appropriate line-side terminals.

The three-phase busbar systems are finger-safe. They are designed for any short-circuit stress which can occur at the load side of connected motor starter protectors.

The three-phase busbar systems can also be used to construct "Type E Starters" of size S0 or S2 according to UL/CSA. Special feeder terminals must be used for this purpose, however (see Selection and Ordering Data).

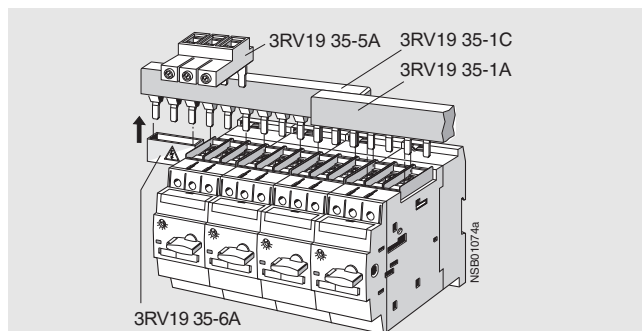

3-phase busbar system, size S2

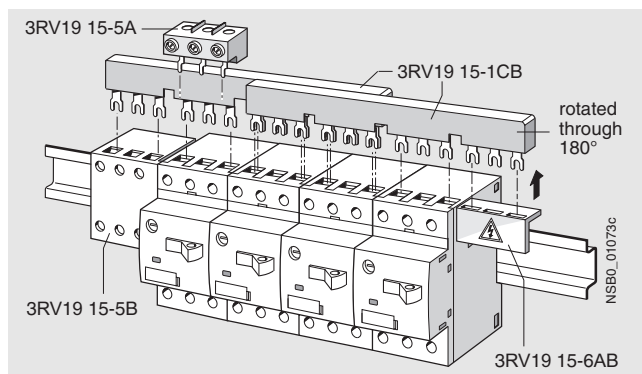

3-phase busbar system, size S00

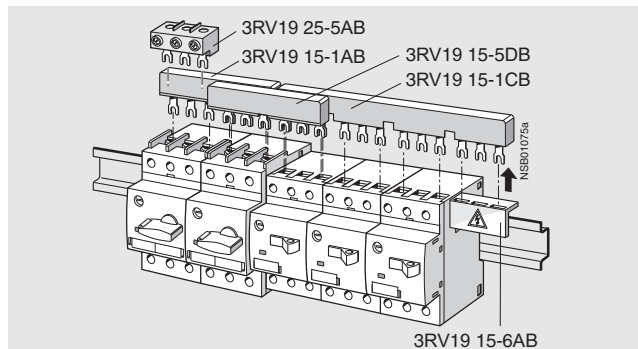

3-phase busbar system, with example for combining sizes S00 and S0

Busbar adapters

The motor starter protectors are mounted directly with the aid of busbar adapters on busbar systems with 40 mm and 60 mm center-line spacing in order to save space and to reduce infeed times and costs.

Busbar adapters for busbar systems with 40 mm center-line spacing are suitable for copper busbars with a width of 12 mm to 15 mm, while those with 60 mm center-line spacing are suitable for copper busbars with a width of 12 mm to 30 mm. The busbars can be 4 to 5 mm or 10 mm thick.

The motor starter protectors are snapped onto the adapter and connected on the line side. This prepared unit is then plugged directly onto the busbar system, and is thus connected both mechanically and electrically at the same time.

Further busbar adapters for snap-mounting direct-on-line starters and reversing starters as well as additional accessories such as line terminals and outgoing terminals, busbar copper, etc., can be found under "Distribution/Busbar Systems and Controlgear".

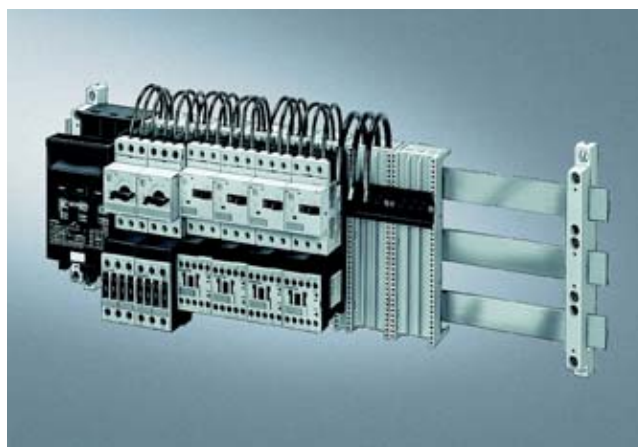

SIRIUS motor starter protectors and load feeders with busbar adapters snapped onto busbars



The 3RV19 infeed system can be found under "Load Feeders, Motor Starters and Soft Starters", "3RA Fuseless Load Feeders".

3RV Motor Starter Protectors up to 100 A

Accessories

Busbar accessories

Selection and ordering data

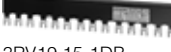
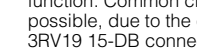
| | Modular spacing mm | Number of motor starter protectors that can be connected | | | Rated current I_n at 690 V A | For motor starter protectors Size | DT | Order No. | Price per PU | PU (UNIT, SET, M) | PS* | PG | Weight per PU approx. kg | | | | |
|---|-----------------------|--|-------------------------------|------------------------|-----------------------------------|-----------------------------------|----|---------------------|--------------|-------------------|--------|-----|-----------------------------|---|--------|-----|-------|
| | | without lateral accessories | with lateral auxiliary switch | with auxiliary release | | | | | | | | | | | | | |
| 3-phase busbar systems | | | | | | | | | | | | | | | | | |
| For feeding several motor starter protectors with screw-type connection, mounted side-by-side on standard mounting rails, insulated, with touch protection. | | | | | | | | | | | | | | | | | |
|  3RV19 15-1AB | 45 | 2 | - | - | 63 | S00, S0 ¹⁾ | ▶ | 3RV19 15-1AB | | 1 | 1 unit | 101 | 0.044 | | | | |
| | | 3 | | | | | | 3RV19 15-1BB | | | | | | 1 | 1 unit | 101 | 0.071 |
| | | 4 | | | | | | 3RV19 15-1CB | | | | | | 1 | 1 unit | 101 | 0.099 |
| | | 5 | | | | | | 3RV19 15-1DB | | | | | | 1 | 1 unit | 101 | 0.124 |
|  3RV19 15-1BB | 55 | - | 2 | - | 63 | S00, S0 ¹⁾ | ▶ | 3RV19 15-2AB | | 1 | 1 unit | 101 | 0.048 | | | | |
| | | 3 | | | | | | 3RV19 15-2BB | | | | | | 1 | 1 unit | 101 | 0.079 |
| | | 4 | | | | | | 3RV19 15-2CB | | | | | | 1 | 1 unit | 101 | 0.111 |
| | | 5 | | | | | | 3RV19 15-2DB | | | | | | 1 | 1 unit | 101 | 0.140 |
|  3RV19 15-1CB | 63 | - | - | 2 | 63 | S00, S0 ¹⁾ | ▶ | 3RV19 15-3AB | | 1 | 1 unit | 101 | 0.052 | | | | |
| | | 4 | | | | | | 3RV19 15-3CB | | | | | | 1 | 1 unit | 101 | 0.120 |
|  3RV19 15-1CB | 55 | 2 | - | - | 108 | S2 | ▶ | 3RV19 35-1A | | 1 | 1 unit | 101 | 0.140 | | | | |
| | | 3 | | | | | | 3RV19 35-1B | | | | | | 1 | 1 unit | 101 | 0.214 |
| | | 4 | | | | | | 3RV19 35-1C | | | | | | 1 | 1 unit | 101 | 0.295 |
|  3RV19 15-1DB | 75 | - | 2 | 2 | 108 | S2 ²⁾ | A | 3RV19 35-3A | | 1 | 1 unit | 101 | 0.161 | | | | |
| | | 3 | 3 | 3 | | | | 3RV19 35-3B | | | | | | 1 | 1 unit | 101 | 0.262 |
| | | 4 | 4 | 4 | | | | 3RV19 35-3C | | | | | | 1 | 1 unit | 101 | 0.369 |

1) Not suitable for 3RV11 motor starter protectors with overload relay function. Common clamping of S00 and S0 motor starter protectors is not possible, due to the different modular spacings and terminal heights. The 3RV19 15-DB connector is available for connecting busbars from size S0 to size S00.

2) Auxiliary releases and lateral auxiliary switches cannot be used in combination.



| Version | Modular spacing mm | For motor starter protectors Size | DT | Order No. | Price per PU | PU (UNIT, SET, M) | PS* | PG | Weight per PU approx. kg |
|---------|-----------------------|-----------------------------------|----|-----------|--------------|-------------------|-----|----|-----------------------------|
|---------|-----------------------|-----------------------------------|----|-----------|--------------|-------------------|-----|----|-----------------------------|

Connectors for 3-phase busbars

| | | | | | | | | | | |
|---|---|----|---------|---|---------------------|--|---|--------|-----|-------|
|  3RV19 15-5DB | For connecting three-phase busbars for motor starter protectors of size S0 (left) to size S00 (right) | 45 | S00, S0 | ▶ | 3RV19 15-5DB | | 1 | 1 unit | 101 | 0.042 |
|---|---|----|---------|---|---------------------|--|---|--------|-----|-------|

| Conductor cross-section | | For motor starter protectors Size | DT | Order No. | Price per PU | PU (UNIT, SET, M) | PS* | PG | Weight per PU approx. kg |
|-------------------------|---------------------------------|-----------------------------------|----|-----------|--------------|-------------------|-----|----|-----------------------------|
| Solid or stranded | Finely stranded with end sleeve | | | | | | | | |

3-phase line-side terminals

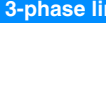
| | | | | | | | | | | |
|---|----------------------------|------------|------|---------|---|---------------------|---|--------|-----|-------|
| Connection from top | | | | | | | | | | |
|  3RV19 25-5AB | 2.5 ... 25 | 4 ... 16 | 12-4 | S00 | ▶ | 3RV19 15-5A | 1 | 1 unit | 101 | 0.043 |
| | | | | S0 | ▶ | 3RV19 25-5AB | 1 | 1 unit | 101 | 0.041 |
| Connection from below¹⁾ | | | | | | | | | | |
|  3RV19 15-5B | 2.5 ... 25 | 4 ... 16 | 12-4 | S00, S0 | ▶ | 3RV19 15-5B | 1 | 1 unit | 101 | 0.110 |
| | Connection from top | | | | | | | | | |
|  3RV19 35-5A | 2.5 ... 50 | 1.5 ... 35 | 14-0 | S2 | ▶ | 3RV19 35-5A | 1 | 1 unit | 101 | 0.115 |

3-phase line-side terminals for constructing "Type E Starters"

Connection from top

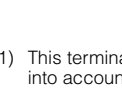
| | | | | | | | | | | |
|---|------------|----------|------|----|---|---------------------|---|--------|-----|-------|
|  3RV19 25-5EB | 2.5 ... 25 | 4 ... 16 | 10-4 | S0 | C | 3RV19 25-5EB | 1 | 1 unit | 101 | 0.055 |
| | 10 ... 50 | - | 8-0 | S2 | ▶ | 3RV19 35-5E | 1 | 1 unit | 101 | 0.100 |

1) This terminal is connected in place of a switch, please take the spacing into account.

3RV Motor Starter Protectors up to 100 A

Accessories

Busbar accessories

| Version | For motor starter protectors Size | DT | Order No. | Price per PU | PU (UNIT, SET, M) | PS* | PG | Weight per PU approx. kg |
|---------|-----------------------------------|----|-----------|--------------|-------------------|-----|----|--------------------------|
|---------|-----------------------------------|----|-----------|--------------|-------------------|-----|----|--------------------------|

Covers for connection tags



3RV19 15-6AB

Touch protection for empty positions

S00, S0

▶ **3RV19 15-6AB**

1

10 units

101

0.003

S2

▶ **3RV19 35-6A**

1

5 units

101

0.006

Busbar adapters



8US10 61-5DJ07



8US12 51-5MD07

| For motor starter protectors Size | Rated current A | Connection cable AWG | Adapter length mm | Adapter width mm | Rated voltage V | DT | Order No. | Price per PU | PU (UNIT, SET, M) | PS* | PG | Weight per PU approx. kg |
|-----------------------------------|-----------------|----------------------|-------------------|------------------|-----------------|----|-----------|--------------|-------------------|-----|----|--------------------------|
|-----------------------------------|-----------------|----------------------|-------------------|------------------|-----------------|----|-----------|--------------|-------------------|-----|----|--------------------------|

Busbar adapters for 40 mm systems

For copper busbars according to DIN 46433
Width: 12 mm and 15 mm
Thickness: 5 mm and 10 mm

| | | | | | | | | | | | | |
|------------------------------------|-----|----|-----|----|---------------------------|---|-----------------------|--|---|--------|-----|-------|
| S00, S0 | 25 | 12 | 121 | 45 | 690 | ▶ | 8US10 51-5DJ07 | | 1 | 1 unit | 103 | 0.106 |
| S00, S0 + lateral auxiliary switch | 25 | 12 | 121 | 55 | 690 | ▶ | 8US10 61-5DJ07 | | 1 | 1 unit | 103 | 0.119 |
| S2 | 56 | 8 | 139 | 55 | 690 | ▶ | 8US10 61-5FK08 | | 1 | 1 unit | 103 | 0.231 |
| S3 | 100 | 4 | 182 | 70 | 400 ¹⁾ | ▶ | 8US11 11-4SM00 | | 1 | 1 unit | 103 | 0.541 |
| S3 | 100 | 4 | 182 | 72 | 480 ... 690 ²⁾ | ▶ | 8US10 11-4TM00 | | 1 | 1 unit | 103 | 0.478 |

Busbar adapters for 60 mm systems

For copper busbars according to DIN 46433
Width: 12 mm and 30 mm
Thickness: 5 mm and 10 mm
also for T and double-T special profiles

| | | | | | | | | | | | | |
|---------|-----|----|-----|----|---------------------------|---|-----------------------|--|---|---------|-----|-------|
| S00, S0 | 25 | 12 | 182 | 45 | 690 | ▶ | 8US12 51-5DM07 | | 1 | 1 unit | 103 | 0.183 |
| S2 | 56 | 8 | | 55 | 690 | ▶ | 8US12 61-5FM08 | | 1 | 6 units | 103 | 0.263 |
| S3 | 100 | 4 | | 70 | 400 ¹⁾ | ▶ | 8US11 11-4SM00 | | 1 | 1 unit | 103 | 0.541 |
| S3 | 100 | 4 | | 72 | 480 ... 690 ²⁾ | ▶ | 8US12 11-4TM00 | | 1 | 1 unit | 103 | 0.498 |

1) Up to 460 V AC with max. short-circuit breaking capacity 25 kA.

- 2) Cannot be used for voltages < 480 V AC
Short-circuit breaking capacity 480 V/ 500 V/ 525 V AC:
- up to $I_n = 25$ A: max. 30 kA
- up to $I_n = 90$ A: max. 16 kA
- up to $I_n = 100$ A: max. 6 kA
Short-circuit breaking capacity 690 V AC:
- max. 12 kA.

For more busbar adapters, see "SIVACON Switchgear, Distribution Systems and Cabinets " -->

"Components for Distribution Systems 8US, 8UC, 4NC"

3RV Motor Starter Protectors up to 100 A

Accessories

Rotary operating mechanisms

Overview

Door-coupling rotary operating mechanisms

Motor starter protectors with a rotary operating mechanism can be mounted in a control cabinet and operated externally by means of a door-coupling rotary operating mechanism. When the cabinet door with motor starter protector is closed, the operating mechanism is coupled. When the motor starter protector closes, the coupling is locked which prevents the door from being opened unintentionally. This lock can be defeated by the maintenance personnel. In the Open position, the rotary operating mechanism can be secured against reclosing with up to 3 padlocks. Inadvertent opening of the door is not possible in this case either.

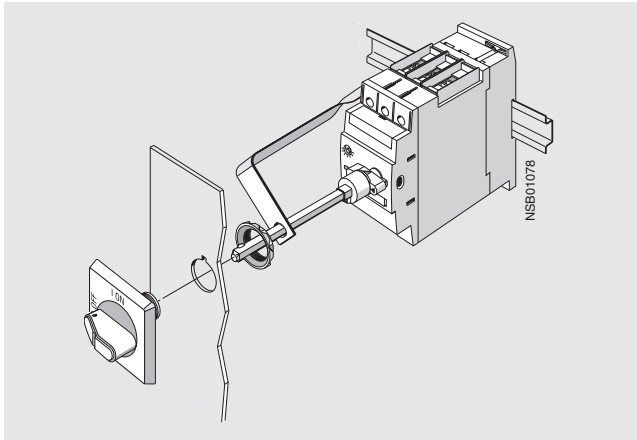

3RV19 26-0K door-coupling rotary operating mechanism

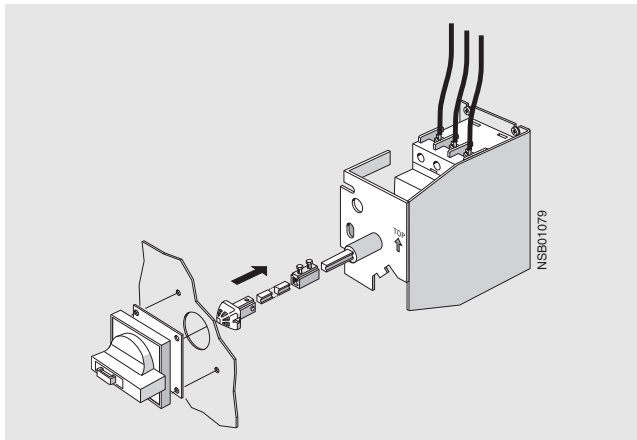

3RV19 26-2B door-coupling rotary operating mechanism for arduous conditions

Remote motorized operating mechanisms

3RV1 motor starter protectors are manually operated controls. They automatically trip in case of an overload or short-circuit. Intentional remote-controlled tripping is possible by means of a shunt release or an undervoltage release. Reclosing is only possible directly at the motor starter protector.

The remote motorized operating mechanism allows the motor starter protectors to be opened and closed by electrical commands. This enables a load or an installation to be isolated from the power system or reconnected to it from an operator panel.

If the motor starter protector is tripped as a result of overload or short-circuit, it will be in tripped position. For reclosing, the remote motorized operating mechanism must first be set manually or electrically to the 0 position (electrically by means of the Open command). Then it can be reclosed.

The remote motorized operating mechanism is available for motor starter protectors of size S2 ($I_{nmax} = 50 A$) and S3 ($I_{nmax} = 100 A$) that are designed for control voltages of 230 V AC and 24 V DC. The motor starter protector is fitted into the remote motorized operating mechanism as shown in the drawing.

In the "MANUAL" position, the motor starter protector in the remote motorized operating mechanism can continue to be switched manually on site. In the "AUTOMATIC" position, the motor starter protector is switched by means of electrical commands. The switching command must be applied for a minimum of 100 ms. The remote motorized operating mechanism closes the motor starter protector after a maximum of 1 second. On voltage failure during the switching operation it is ensured that the motor starter protector remains in the Open or Closed position.

Reset function

The RESET button on the motorized operating mechanism serves to reset any 3RV19 21-1M alarm switch that might be installed.

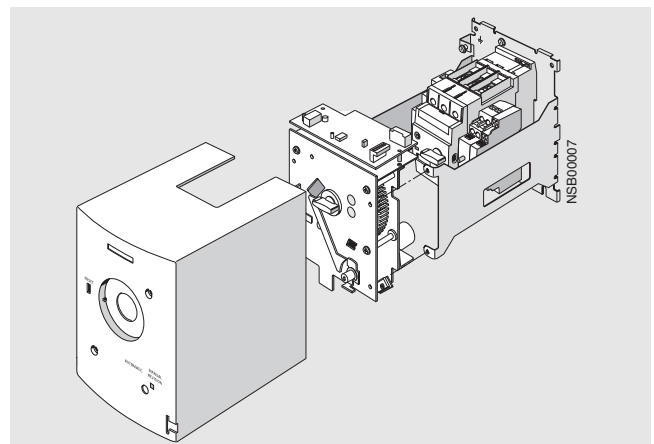

Selection and ordering data

| Type | Color of knob | Version Extension shaft mm | For motor starter protectors Size | DT | Order No. | Price per PU | PU (UNIT, SET, M) | PS* | PG | Weight per PU approx. kg |
|------|---------------|----------------------------------|--------------------------------------|----|-----------|--------------|-------------------|-----|----|-----------------------------|
|------|---------------|----------------------------------|--------------------------------------|----|-----------|--------------|-------------------|-----|----|-----------------------------|

Door-coupling rotary operating mechanisms



3RV19 26-0B

The door-coupling rotary operating mechanisms consist of a knob, a coupling driver and an extension shaft of 130/330 mm in length (5 x 5 mm). The door-coupling rotary operating mechanisms are designed to the degree of protection IP65. The door locking device prevents accidental opening of the control cabinet door in the ON position of the motor starter protector. The OFF position can be locked with up to 3 padlocks.

| | | | | | | | | | | |
|---|-------------|-----|------------|---|--------------------|--|---|--------|-----|-------|
| Door-coupling rotary operating mechanisms | Black | 130 | S0, S2, S3 | ▶ | 3RV19 26-0B | | 1 | 1 unit | 101 | 0.111 |
| | | 330 | | ▶ | 3RV19 26-0K | | 1 | 1 unit | 101 | 0.324 |
| EMERGENCY-STOP door-coupling rotary operating mechanisms | Red/ Yellow | 130 | S0, S2, S3 | ▶ | 3RV19 26-0C | | 1 | 1 unit | 101 | 0.110 |
| | | 330 | | ▶ | 3RV19 26-0L | | 1 | 1 unit | 101 | 0.316 |

Door-coupling rotary operating mechanisms, for arduous conditions



3RV19 26-2C

The door-coupling rotary operating mechanisms consist of a knob, a coupling driver, an extension shaft of 300 mm in length (8 x 8 mm), a spacer and two metal brackets, into which the motor starter protector is inserted. The door-coupling rotary operating mechanisms are designed to degree of protection IP65. The door locking device reliably prevents opening of the control cabinet door in the ON position of the circuit-breaker. The OFF position can be locked with up to 3 padlocks. Laterally mountable auxiliary releases and two-pole auxiliary switches can be used. The door-coupling rotary operating mechanism thus meets the requirements for isolating functions to IEC 60947-2.

| | | | | | | | | | | |
|---|-------------|-----|----|---|--------------------|--|---|--------|-----|-------|
| Door-coupling rotary mechanisms | Gray | 300 | S0 | ▶ | 3RV19 26-2B | | 1 | 1 unit | 101 | 1.180 |
| | | | S2 | ▶ | 3RV19 36-2B | | 1 | 1 unit | 101 | 1.570 |
| | | | S3 | ▶ | 3RV19 46-2B | | 1 | 1 unit | 101 | 1.722 |
| EMERGENCY-STOP door-coupling rotary operating mechanisms | Red/ Yellow | 300 | S0 | ▶ | 3RV19 26-2C | | 1 | 1 unit | 101 | 1.188 |
| | | | S2 | ▶ | 3RV19 36-2C | | 1 | 1 unit | 101 | 1.486 |
| | | | S3 | ▶ | 3RV19 46-2C | | 1 | 1 unit | 101 | 1.732 |

| Type | Rated control supply voltage U_s | For motor starter protectors Size | DT | Order No. | Price per PU | PU (UNIT, SET, M) | PS* | PG | Weight per PU approx. kg |
|------|------------------------------------|--------------------------------------|----|-----------|--------------|-------------------|-----|----|-----------------------------|
|------|------------------------------------|--------------------------------------|----|-----------|--------------|-------------------|-----|----|-----------------------------|

Remote motorized operating mechanisms



| | | | | | | | | | |
|--|--------------------|----|---|----------------------|--|---|--------|-----|-------|
| Remote motorized operating mechanisms | 50/60 Hz, 230 V AC | S2 | B | 3RV19 36-3AP0 | | 1 | 1 unit | 101 | 3.520 |
| | 24 V DC | S2 | B | 3RV19 36-3AB4 | | 1 | 1 unit | 101 | 3.420 |
| | 50/60 Hz, 230 V AC | S3 | B | 3RV19 46-3AP0 | | 1 | 1 unit | 101 | 3.441 |
| | 24 V DC | S3 | B | 3RV19 46-3AB4 | | 1 | 1 unit | 101 | 3.357 |

3RV Motor Starter Protectors up to 100 A

Accessories

Mounting accessories

Overview

Soldering terminal

Soldering terminals are available for the main contacts and transverse auxiliary switches of size S00 motor starter protectors.

The prepared terminal parts are clamped to the upper and lower screw terminals of the motor starter protectors which allows them to be soldered into printed circuit boards.

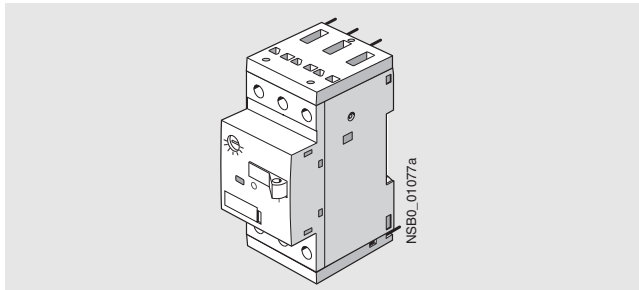

3RV19 18-5A

The 3RV19 28-1H terminal block must be used here for size S0; it is simply screwed onto the basic unit.

Basic units of size S2 are already compliant with the new clearance and creepage distance requirements.

The 3RT19 46-4GA07 terminal block must be used for size S3. The standard box terminal is to be replaced by this terminal block.

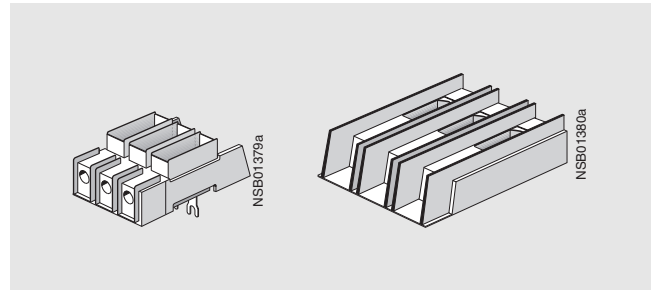

3RV19 28-1H (left), 3RT19 46-4GA07 (right)

Terminals for "Self-Protected Combination Motor Controller (Type E)" according to UL508

The 3RV10 motor starter protectors are approved according to UL508 as a "Self-Protected Combination Motor Controllers (Type E)".

As of 16 July 2001, for this application, UL 508 demands increased clearance and creepage distances (1 inch and 2 inches respectively) at the line side of the device.

According to CSA, these modular terminals can be omitted when the device is used as a "Self-Protected Combination Motor Controller" (Type E).

Three-phase line-side terminals are required for constructing "Type E Starters" with an insulated busbar system (see Busbar Accessories).

Selection and ordering data

| Version | For motor starter protectors Size | DT | Order No. | Price per PU | PU (UNIT, SET, M) | PS* | PG | Weight per PU approx. kg |
|---------|-----------------------------------|----|-----------|--------------|-------------------|-----|----|--------------------------|
|---------|-----------------------------------|----|-----------|--------------|-------------------|-----|----|--------------------------|

| Covers | | | | | | | | |
|--------|---|----------------|---|----------------------|-----|----------|-----|-------|
| | Terminal covers for box terminals Additional touch protection for fitting to box terminals (2 units can be mounted per motor starter protector) | S2 | ▶ | 3RT19 36-4EA2 | 1 | 1 unit | 101 | 0.016 |
| | | S3 | ▶ | 3RT19 46-4EA2 | 1 | 1 unit | 101 | 0.023 |
| | Terminal covers For cable lug and bar connection for maintaining the required voltage clearance and as touch protection if box terminal is removed (2 units can be mounted per motor starter protector) | S3 | ▶ | 3RT19 46-4EA1 | 1 | 1 unit | 101 | 0.037 |
| | Scale covers Sealable, for covering the set current scale. | S0, S0, S2, S3 | ▶ | 3RV19 08-0P | 100 | 10 units | 101 | 0.100 |

3RV1 (size S3) with 3RT19 46-4EA1 (left) 3RV19 08-0P (right)

* You can order this quantity or a multiple thereof.

3RV Motor Starter Protectors up to 100 A

Accessories

Mounting accessories

| Type | Version | For motor starter protectors Size | DT | Order No. | Price per PU | PU (UNIT, SET, M) | PS* | PG | Weight per PU approx. kg |
|------|---------|-----------------------------------|----|-----------|--------------|-------------------|-----|----|--------------------------|
|------|---------|-----------------------------------|----|-----------|--------------|-------------------|-----|----|--------------------------|

Fixing accessories



3RB19 00-0B

| | | | | | | | | | |
|---------------------|--|---------|---|--------------------|--|-----|----------|-----|-------|
| Push-in lugs | For screwing the motor starter protector onto mounting plates. For each motor starter protector, 2 units are required. | S00, S0 | ▶ | 3RB19 00-0B | | 100 | 10 units | 101 | 0.100 |
|---------------------|--|---------|---|--------------------|--|-----|----------|-----|-------|

Soldering terminals



3RV19 18-5A with motor starter protector

| | | | | | | | | | |
|--|---|-----|---|--------------------|--|---|--------|-----|-------|
| For main contacts | For soldering the main conductor cross-sections of a motor starter protector to a printed circuit board (1 set = 2 parts for 1 motor starter protector) | S00 | B | 3RV19 18-5A | | 1 | 4 sets | 101 | 0.030 |
| For main and auxiliary contacts | For soldering the main conductor connections and the auxiliary conductor connections of the transverse auxiliary switch 1NO + 1NC of a motor starter protector to a printed circuit board (1 set = 3 parts for 1 motor starter protector) | S00 | B | 3RV19 18-5B | | 1 | 4 sets | 101 | 0.044 |

| Type | Version | For motor starter protectors Size | DT | Order No. | Price per PU | PU (UNIT, SET, M) | PS* | PG | Weight per PU approx. kg |
|------|---------|-----------------------------------|----|-----------|--------------|-------------------|-----|----|--------------------------|
|------|---------|-----------------------------------|----|-----------|--------------|-------------------|-----|----|--------------------------|

Terminals for "Self-Protected Combination Motor Controller (Type E)" according to UL508



3RV19 28-1H



3RT19 46-4GA07

Note: As of 16 July 2001, UL508 demands for "Combination Motor Controller Type E" 1-inch clearance and 2-inch creepage distance at line side. The following terminal blocks must be used in 3RV10 motor starter protectors of sizes S0 and S3. The 3RV10 motor starter protector in size S2 conforms with the required clearance and creepage distances without a terminal block. Terminal blocks are not required for use according to CSA. With size S0, these terminal blocks cannot be used in combination with 3RV19.5 three-phase busbars and with size S3, they cannot be used with a transverse auxiliary switch. For construction with 3-phase busbars, see "Busbar Accessories".

| | | | | | | | | | |
|-------------------------------|--|----------|---|---|--|--------|------------------|------------|----------------|
| Terminal blocks Type E | For extended clearance and creepage distances (1-inch and 2-inch respectively) | S0 S3 | ▶ | 3RV19 28-1H 3RT19 46-4GA07 | | 1 1 | 1 unit 1 unit | 101 101 | 0.083 0.155 |
|-------------------------------|--|----------|---|---|--|--------|------------------|------------|----------------|

| Type | Version | For motor starter protectors Size | DT | Order No. | Price per PU | PU (UNIT, SET, M) | PS* | PG | Weight per PU approx. kg |
|------|---------|-----------------------------------|----|-----------|--------------|-------------------|-----|----|--------------------------|
|------|---------|-----------------------------------|----|-----------|--------------|-------------------|-----|----|--------------------------|

Auxiliary terminals, 3-pole



3RT19 46-4F





| | | | | | | | | | |
|--|---|----|---|--------------------|--|---|--------|-----|-------|
| | For connection of auxiliary and control cables to the main conductor connections (for one side) | S3 | B | 3RT19 46-4F | | 1 | 1 unit | 101 | 0.033 |
|--|---|----|---|--------------------|--|---|--------|-----|-------|

* You can order this quantity or a multiple thereof.

3RV Motor Starter Protectors up to 100 A

Accessories

Mounting accessories

| Version | Method of operation | Size Contactor | Motor starter protector | DT | Order No. | Price per PU | PU (UNIT, SET, M) | PS* | PG | Weight per PU approx. kg | |
|---|---|----------------|-------------------------|-----------------------|-----------|-----------------------|-------------------|-----|----------|--------------------------|-------|
| Link modules, single unit packaging | | | | | | | | | | | |
|  3RA19 11-1AA00 | For mechanical and electrical connection between contactor and motor starter protector with screw connection | AC/DC | S00 | S00 | ▶ | 3RA19 11-1AA00 | | 1 | 1 unit | 101 | 0.027 |
| | | | S00 | S0 | ▶ | 3RA19 21-1DA00 | | 1 | 1 unit | 101 | 0.028 |
| | | AC | S0 | S0 | ▶ | 3RA19 21-1AA00 | | 1 | 1 unit | 101 | 0.037 |
| | | | S2 | S2 | ▶ | 3RA19 31-1AA00 | | 1 | 1 unit | 101 | 0.042 |
| | | | S3 | S3 | ▶ | 3RA19 41-1AA00 | | 1 | 1 unit | 101 | 0.090 |
| | | DC | S0 | S0 | ▶ | 3RA19 21-1BA00 | | 1 | 1 unit | 101 | 0.039 |
| S2 | S2 | | ▶ | 3RA19 31-1BA00 | | 1 | 1 unit | 101 | 0.043 | | |
| S3 | S3 | | ▶ | 3RA19 41-1BA00 | | 1 | 1 unit | 101 | 0.089 | | |
| Link modules, multi-unit packaging | | | | | | | | | | | |
|  3RA19 31-1A | For mechanical and electrical connection between contactor and motor starter protector with screw connection | AC/DC | S00 | S00 | ▶ | 3RA19 11-1A | | 1 | 10 units | 101 | 0.019 |
| | | | S00 | S0 | ▶ | 3RA19 21-1D | | 1 | 10 units | 101 | 0.021 |
| | | AC | S0 | S0 | ▶ | 3RA19 21-1A | | 1 | 10 units | 101 | 0.028 |
| | | | S2 | S2 | ▶ | 3RA19 31-1A | | 1 | 5 units | 101 | 0.033 |
| | | | S3 | S3 | ▶ | 3RA19 41-1A | | 1 | 5 units | 101 | 0.072 |
| | | DC | S0 | S0 | ▶ | 3RA19 21-1B | | 1 | 10 units | 101 | 0.030 |
| S2 | S2 | | ▶ | 3RA19 31-1B | | 1 | 5 units | 101 | 0.034 | | |
| S3 | S3 | | ▶ | 3RA19 41-1B | | 1 | 5 units | 101 | 0.073 | | |
| Hybrid link modules, single-unit packaging | | | | | | | | | | | |
|  3RA19 11-2FA00 | Electrical and mechanical connection between motor starter protector with screw terminals and contactor with Cage Clamp terminals | AC/DC | S00 | S00 | ▶ | 3RA19 11-2FA00 | | 1 | 1 unit | 101 | 0.038 |
| | | | S00 | S0 | ▶ | 3RA19 21-2FA00 | | 1 | 1 unit | 101 | 0.028 |
| Hybrid link modules, multi-unit packaging | | | | | | | | | | | |
|  3RA19 11-2F | Electrical and mechanical connection between motor starter protector with screw terminals and contactor with Cage Clamp terminals | AC/DC | S00 | S00 | ▶ | 3RA19 11-2F | | 1 | 10 units | 101 | 0.031 |
| | | | S00 | S0 | ▶ | 3RA19 21-2F | | 1 | 10 units | 101 | 0.030 |

3RV Motor Starter Protectors up to 100 A

Accessories

Mounting accessories

| Type | Version | DT | Order No. | Price per PU | PU (UNIT, SET, M) | PS* | PG | Weight per PU approx. kg |
|------|---------|----|-----------|--------------|-------------------|-----|----|--------------------------|
|------|---------|----|-----------|--------------|-------------------|-----|----|--------------------------|

Adapters and link modules for Cage Clamp connections



3RA19 11-2A +
8US10 51-5CM47



3RA19 11-2E

| | | | | | | | | |
|--|---------------------|---|-----------------------|--|---|----------|-----|-------|
| Link modules, Cage Clamp Electrical connection between motor starter protector and contactor (busbar adapter not included in scope of supply) | Size S00 | ▶ | 3RA19 11-2A | | 1 | 10 units | 101 | 0.016 |
| Link modules, Cage Clamp with mechanical connections Mechanical and electrical connection between motor starter protector and contactor | Size S00 | ▶ | 3RA19 11-2E | | 1 | 10 units | 101 | 0.028 |
| Adapters for rail mounting With 2 mounting rails 45 mm wide, one adjustable | Size S00 | ▶ | 3RA19 22-1L | | 1 | 5 units | 101 | 0.413 |
| Busbar adapters 45 mm wide, 182 mm long, adapted for Cage Clamp motor starter protectors. An additional mounting rail must be mounted for an additional contactor. | 40 mm busbar system | ▶ | 8US10 51-5CM47 | | 1 | 1 unit | 103 | 0.193 |
| | 60 mm busbar system | ▶ | 8US12 51-5CM47 | | 1 | 1 unit | 103 | 0.190 |
| 35 mm standard mounting rails Plastic, including fixing screws | | A | 8US19 98-7CA15 | | 1 | 10 units | 103 | 0.009 |

| Type | Version | DT | Order No. | Price per PU | PU (UNIT, SET, M) | PS* | PG | Weight per PU approx. kg |
|------|---------|----|-----------|--------------|-------------------|-----|----|--------------------------|
|------|---------|----|-----------|--------------|-------------------|-----|----|--------------------------|

Tools for opening Cage Clamp connections



| | | | | | | | | |
|---|--|---|-----------------|--|---|--------|-----|-------|
| For all SIRIUS devices with Cage Clamp connection, up to max. 2.5 mm ² conductor cross-section | Length approx. 175 mm | ▶ | 8WA2 880 | | 1 | 1 unit | 041 | 0.012 |
| | Length; partially insulated approx. 175 mm | ▶ | 8WA2 803 | | 1 | 1 unit | 041 | 0.024 |

3RV Motor Starter Protectors up to 100 A

Accessories

Enclosures and front plates

Overview

Enclosures

For installing motor starter protectors of sizes S00 ($I_{nmax} = 12\text{ A}$), S0 ($I_{nmax} = 25\text{ A}$) and S2 ($I_{nmax} = 50\text{ A}$) as a single unit, molded-plastic enclosures for surface mounting and molded-plastic enclosures for flush mounting are available in various dimensions.

When installed in a molded-plastic enclosure the motor starter protectors have a rated operational voltage U_e of 500 V

The enclosures for surface mounting have the degree of protection IP55; the enclosures for flush mounting also comply with the degree of protection IP55 at the front (the flush-mounted section complies with IP20).

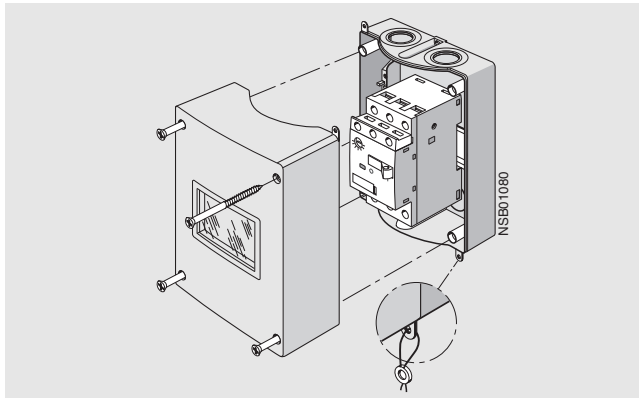

Enclosure for surface mounting

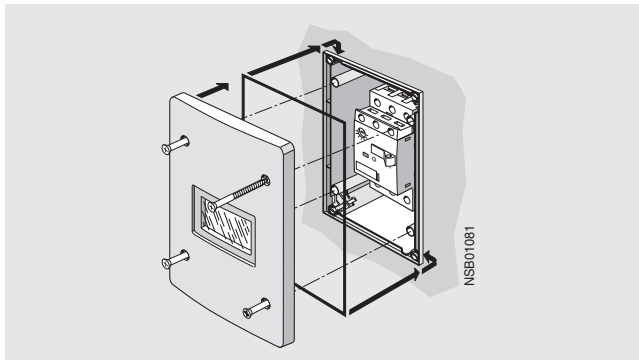

Enclosure for flush mounting

All enclosures are equipped with N and PE/ground terminals. There are two knock-out cable entries for cable glands at the top and two at the bottom; also on the rear corresponding cable entries are scored. There is a knock-out on the top of the enclosure for indicator lights that are available as accessories.

The narrow enclosure can accommodate a motor starter protector without accessories, with transverse and lateral auxiliary switch, whereas wide enclosures and enclosures for S2 motor starter protectors also provide space for a laterally mounted auxiliary release. There is no provision for installing a motor starter protector with an alarm switch.

With S00 motor starter protectors, the switch rocker is operated by means of the actuator diaphragm of the enclosure. A locking device, capable of holding up to three padlocks, can be fitted onto the actuator diaphragm to prevent the motor starter protector from closing during maintenance work, for example.

A mushroom-shaped EMERGENCY-STOP knob can be fitted in place of the locking device. If it is actuated abruptly, the motor starter protector opens and the mushroom-shaped knob latches. The knob can be unlatched again either by turning it or

by using a special key. The motor starter protector can subsequently be switched on again.

The molded-plastic enclosures of S0 and S2 motor starter protectors with rotary operating mechanism are fitted with a rotary operating mechanism as well.

The enclosures can be supplied with a black rotary operating mechanism or with an EMERGENCY-STOP rotary operating mechanism with a red/yellow knob.

All rotary operating mechanisms can be locked in the Open position with up to 3 padlocks.

Front plates

Motor starter protectors are frequently required to be actuated in any enclosure. Front plates equipped with an actuating diaphragm for size S00 motor starter protectors, or rotary operating mechanism for S0 to S3 motor starter protectors are available for this purpose.

The front plates for size S00 have a retaining frame into which the motor starter protectors can be snapped. A retaining frame for size S0 motor starter protectors is available for front plate sizes S0 to S3.

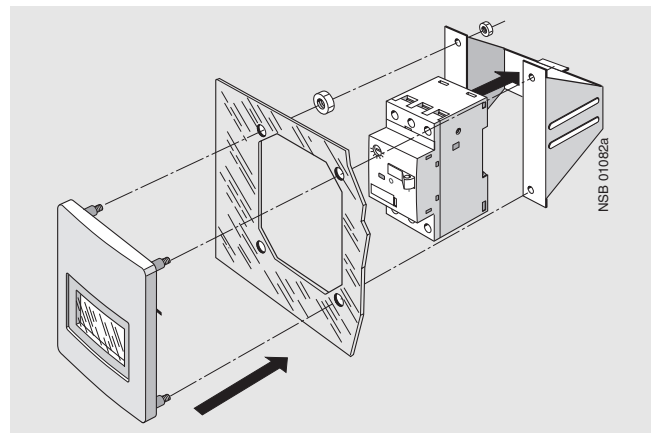

Front plate for size S00

Accessories for enclosures and front plates

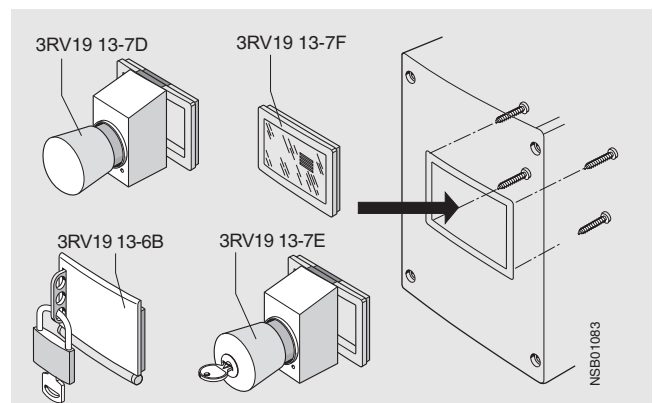







3RV Motor Starter Protectors up to 100 A

Accessories

Enclosures and front plates

Selection and ordering data



| Type | Degree of protection | Integrated terminals | Overall width | For motor starter protectors Size | DT | Order No. | Price per PU | PU (UNIT, SET, M) | PS* | PG | Weight per PU approx. | |
|---|---|----------------------|------------------|--|-----|-------------------------|-----------------------|-------------------|--|--------|-----------------------|-----------------------|
| Molded-plastic enclosures for surface mounting | | | | | | | | | | | | |
|  3RV19 13-1DA00 | With actuator diaphragm | IP55 | N and PE/ground | 54 mm (for motor starter protector + lateral auxiliary switch) | S00 | ▶ 3RV19 13-1CA00 | | 1 | 1 unit | 101 | 0.296 | |
| | | | | 72 mm (for motor starter protector + lateral auxiliary switch + auxiliary release) | | ▶ 3RV19 13-1DA00 | | 1 | 1 unit | 101 | 0.342 | |
|  3RV19 23-1CA00 | With rotary operating mechanism, lockable in 0 position | IP55 | N and PE/ground | 54 mm (for motor starter protector + lateral auxiliary switch) | S0 | ▶ 3RV19 23-1CA00 | | 1 | 1 unit | 101 | 0.332 | |
| | | | | 72 mm (for motor starter protector + lateral auxiliary switch + auxiliary release) | | ▶ 3RV19 23-1DA00 | | 1 | 1 unit | 101 | 0.381 | |
| | | | | 82 mm (for motor starter protector + lateral auxiliary switch + auxiliary release) | S2 | A | 3RV19 33-1DA00 | 1 | 1 unit | 101 | 1.134 | |
|  3RV19 23-1FA00 | With EMERGENCY-STOP rotary operating mechanism, lockable in 0 position | IP55 | N and PE/ground | 54 mm (for motor starter protector + lateral auxiliary switch) | S0 | ▶ 3RV19 23-1FA00 | | 1 | 1 unit | 101 | 0.329 | |
| | | | | 72 mm (for motor starter protector + lateral auxiliary switch + auxiliary release) | | ▶ 3RV19 23-1GA00 | | 1 | 1 unit | 101 | 0.372 | |
| | | | | 82 mm (for motor starter protector + lateral auxiliary switch + auxiliary release) | S2 | A | 3RV19 33-1GA00 | 1 | 1 unit | 101 | 1.136 | |
| Cast aluminum enclosures for surface mounting | | | | | | | | | | | | |
|  3RV19 23-1DA01 | With rotary operating mechanism, lockable in 0 position | IP65 | PE ¹⁾ | 72 mm (for motor starter protector + lateral auxiliary switch + auxiliary release) | S0 | ▶ 3RV19 23-1DA01 | | 1 | 1 unit | 101 | 1.015 | |
| | | | | With EMERGENCY-STOP rotary operating mechanism, lockable in 0 position | | IP65 | | PE ¹⁾ | 72 mm (for motor starter protector + lateral auxiliary switch + auxiliary release) | S0 | A | 3RV19 23-1GA01 |
| Molded-plastic enclosures for flush mounting | | | | | | | | | | | | |
|  3RV19 13-2DA00 | With actuator diaphragm | IP55 (front side) | N and PE/ground | 72 mm (for motor starter protector + lateral auxiliary switch + auxiliary release) | S00 | A | 3RV19 13-2DA00 | | 1 | 1 unit | 101 | 0.416 |
| | | | | With rotary operating mechanism, lockable in 0 position | | | | | | | | |
|  3RV19 23-2DA00 | With EMERGENCY-STOP rotary operating mechanism, lockable in 0 position | IP55 (front side) | N and PE/ground | 72 mm (for motor starter protector + lateral auxiliary switch + auxiliary release) | S0 | A | 3RV19 23-2GA00 | | 1 | 1 unit | 101 | 0.417 |
| | | | | With actuator diaphragm | | | | | | | | |

1) If required, an additional N terminal can be mounted (e.g. 8WA10 11-1BG11).

3RV Motor Starter Protectors up to 100 A

Accessories

Enclosures and front plates

| Type | Degree of protection | Version | For motor starter protectors Size | DT | Order No. | Price per PU | PU (UNIT, SET, M) | PS* | PG | Weight per PU approx. |
|---|---|-------------------|--|------------|-----------|--------------------|-------------------|--------|-----|-----------------------|
| Front plates | | | | | | | | | | |
|  3RV19 13-4C | Molded-plastic front plates with actuator diaphragm | IP55 (front side) | For actuating motor starter protectors in any enclosures, includes holder for motor starter protector. | S00 | A | 3RV19 13-4C | 1 | 1 unit | 101 | 0.216 |
|  3RV19 23-4B + 3RV19 23-4G | Molded-plastic front plates with rotary operating mechanism Lockable in 0 position | IP55 (front side) | For actuating 3RV1 motor starter protectors in any enclosures. | S0, S2, S3 | ▶ | 3RV19 23-4B | 1 | 1 unit | 101 | 0.124 |
| | Molded-plastic front plates with EMERGENCY-STOP rotary operating mechanism Red/Yellow, lockable in 0 position | IP55 (front side) | EMERGENCY-STOP actuation of 3RV1 motor starter protectors in any enclosure. | S0, S2, S3 | A | 3RV19 23-4E | 1 | 1 unit | 101 | 0.124 |
| | Holders for front plate For motor starter protectors size S0 | - | Holder is mounted on front plate, motor starter protector with and without accessories is snapped in. | S0 | ▶ | 3RV19 23-4G | 1 | 1 unit | 101 | 0.188 |

Accessories for enclosures

| | | | | | | | | | | |
|---|---|------|---|-----|---|--------------------|---|--------|-----|-------|
|  Molded-plastic enclosure for surface mounting with 3RV19 13-7D | EMERGENCY-STOP mushroom buttons red/yellow For 3RV19 13-... enclosures and front plates, cannot be used in combination with locking device | IP55 | Latching mushroom button, unlatch by turning | S00 | ▶ | 3RV19 13-7D | 1 | 1 unit | 101 | 0.108 |
| | EMERGENCY-STOP mushroom buttons red/yellow with safety lock For 3RV19 13-... enclosures and front plates, cannot be used in combination with locking device | IP55 | Latching mushroom button, unlatch with key, Ronis safety lock, lock number SB 30, supplied with 2 keys. | S00 | A | 3RV19 13-7E | 1 | 1 unit | 101 | 0.144 |
| | Locking devices For 3RV19 13-... enclosures and front plates, cannot be used in combination with EMERGENCY-STOP mushroom button | IP55 | For 3 padlocks with max. 8 mm shackle diameter. | S00 | ▶ | 3RV19 13-6B | 1 | 1 unit | 101 | 0.074 |
| | Spare actuator diaphragms | IP55 | Diaphragm, includes holder frame and screws | S00 | A | 3RV19 13-7F | 1 | 1 unit | 101 | 0.023 |

| Type | Version | Rated control supply voltage U_s | For motor starter protectors Size | DT | Order No. | Price per PU | PU (UNIT, SET, M) | PS* | PG | Weight per PU approx. |
|------|---------|------------------------------------|-----------------------------------|----|-----------|--------------|-------------------|-----|----|-----------------------|
|------|---------|------------------------------------|-----------------------------------|----|-----------|--------------|-------------------|-----|----|-----------------------|

Indicator Lights

| | | | | | | | | | | |
|--|--|--|--|-------------|------------------|--|------------------|--------------------------------------|--------------------------|----------------------------------|
|  3RV19 03-5B | Indicator lights For all enclosures and front plates | With glow lamp and colored lenses red, green, yellow, orange and clear | 110 ... 120 220 ... 240 380 ... 415 480 ... 500 | S00, S0, S2 | C C C C | 3RV19 03-5B 3RV19 03-5C 3RV19 03-5E 3RV19 03-5G | 1 1 1 1 | 1 unit 1 unit 1 unit 1 unit | 101 101 101 101 | 0.027 0.026 0.026 0.027 |
|--|--|--|--|-------------|------------------|--|------------------|--------------------------------------|--------------------------|----------------------------------|

* You can order this quantity or a multiple thereof.

Overview

| Features | Benefits | 3RU11 | 3RB20/3RB21 | 3RB22/3RB23 |
|--|---|------------------|-------------------|---|
|  | | | | |
| General data | | | | |
| Sizes | <ul style="list-style-type: none"> • Are coordinated with the dimensions, connections and technical characteristics of the other devices in the SIRIUS modular system (contactors, soft starters, ...) • Permit the mounting of slim and compact load feeders in widths of 45 mm (S00), 45 mm (S0), 55 mm (S2), 70 mm (S3), 120 mm (S6) and 145 mm (S10/S12) • Simplify configuration | S00 ... S3 | S00 ... S12 | S00 ... S12 |
| Seamless current range | <ul style="list-style-type: none"> • Allows easy and consistent configuration with one series of overload relays (for small to large loads) | 0.11 ... 100 A | 0.1 ... 630 A | 0.3 ... 630 A (... 820 A) ¹⁾ |
| Protective functions | | | | |
| Tripping in the event of overload | <ul style="list-style-type: none"> • Provides optimum current-dependent protection of loads against excessive temperature rises due to overload | ✓ | ✓ | ✓ |
| Tripping in the event of phase unbalance | <ul style="list-style-type: none"> • Provides optimum inverse-time delayed protection of loads against excessive temperature rises due to phase unbalance | (✓) | ✓ | ✓ |
| Tripping in the event of phase failure | <ul style="list-style-type: none"> • Minimizes heating of three-phase motors during single-phase operation²⁾ | ✓ | ✓ | ✓ |
| Tripping in the event of overheating | <ul style="list-style-type: none"> • Provides optimum temperature-dependent protection of loads against excessive temperature rises e.g. for stator-critical motors or in the event of insufficient coolant flow, contamination of the motor surface or for long starting or braking operations • Eliminates the need for additional special equipment • Saves space in the controlgear cabinet • Reduces wiring overhead and costs | -- ³⁾ | -- ³⁾ | ✓ |
| by means of integrated thermistor motor protection function | | | | |
| Tripping in the event of a ground fault | <ul style="list-style-type: none"> • Provides optimum protection of loads against high-resistance short-circuits or ground faults due to moisture, condensed water, damage to the insulation material, etc. • Eliminates the need for additional special equipment. • Saves space in the controlgear cabinet • Reduces wiring overhead and costs | -- | ✓ (only 3RB21) | ✓ |
| by means of internal ground fault detection (activatable) | | | | |
| Features | | | | |
| RESET function | <ul style="list-style-type: none"> • Allows manual or automatic resetting of the relay | ✓ | ✓ | ✓ |
| TEST function for auxiliary contacts | <ul style="list-style-type: none"> • Allows easy checking of the function and wiring | ✓ | ✓ | ✓ |
| TEST function for electronics | <ul style="list-style-type: none"> • Allows complete checking of the electronics | -- | ✓ | ✓ |
| Status display | <ul style="list-style-type: none"> • Displays the current operating status | ✓ | ✓ | ✓ |
| Large current adjustment button | <ul style="list-style-type: none"> • Makes it easier to set the relay exactly to the correct current value | ✓ | ✓ | ✓ |
| Integrated auxiliary contacts (1 NO + 1 NC) | <ul style="list-style-type: none"> • Allows the load to be switched off if necessary • Can be used to output signals | ✓ | ✓ | ✓ (2 ×) |

1) For motor currents up to 820 A, a current measuring module, e.g. 0.3 ... 3 A, can be used in combination with a 3UF18 series transformer.

2) Single-phase operation: Abnormal operating status of a three-phase asynchronous motor where one phase is interrupted.

3) The SIRIUS 3RN thermistor motor protection devices can be used to provide additional protection temperature-dependent protection.

Overload Relays

General data

| Features | Benefits | 3RU11 | 3RB20/3RB21 | 3RB22/3RB23 |
|---|--|------------|-------------------|-------------------|
|  | | | | |
| Design of load feeders | | | | |
| Short-circuit strength up to 100 kA at 690 V (in conjunction with the corresponding fuses or the corresponding motor starter protector) | <ul style="list-style-type: none"> Provides optimum protection of the loads and operating personnel in the event of short-circuits due to insulation faults or faulty switching operations | ✓ | ✓ | ✓ |
| Electrical and mechanical matching to 3RT1 contactors | <ul style="list-style-type: none"> Simplifies configuration Reduces wiring overhead and costs Enables stand-alone installation as well as space-saving direct mounting | ✓ | ✓ | ✓ ¹⁾ |
| Straight-through transformers for main circuit²⁾ (in this case the cables are routed through the push-through openings of the overload relay and connected directly to the box terminals of the contactor) | <ul style="list-style-type: none"> Reduces contact resistance (only one point of contact) Saves wiring costs (easy, no need for tools, and fast). Saves material costs Reduces installation costs | -- | ✓ (S2 ... S6) | ✓ (S00 ... S6) |
| Spring-loaded terminal connection system for main circuit²⁾ | <ul style="list-style-type: none"> Enables fast connections Permits vibration-resistant connections Enables maintenance-free connections | ✓ (S00) | -- | -- |
| Spring-loaded terminal connection system for auxiliary circuits²⁾ | <ul style="list-style-type: none"> Enables fast connections Permits vibration-resistant connections Enables maintenance-free connections | ✓ | ✓ | ✓ |
| Other features | | | | |
| Temperature compensation | <ul style="list-style-type: none"> Allows the use of the relays at high temperatures without derating Prevents premature tripping Allows compact installation of the controlgear cabinet without space between the units/load feeders Simplifies configuration Enables space to be saved in the controlgear cabinet | ✓ | ✓ | ✓ |
| Very high long-term stability | <ul style="list-style-type: none"> Provides safe protection for the loads even after years of use in severe operating conditions | (✓) | ✓ | ✓ |
| Wide setting ranges | <ul style="list-style-type: none"> Reduce the number of variants Minimize the engineering outlay and costs Minimize storage overhead, storage costs, tied-up capital | -- | ✓ (1:4) | ✓ (1:10) |
| Trip class CLASS 5 | <ul style="list-style-type: none"> Enables solutions for very fast starting motors requiring special protection (e.g. Ex motors) | -- | ✓ (only 3RB21) | ✓ |
| Trip class > CLASS 10 | <ul style="list-style-type: none"> Enables heavy starting solutions | -- | ✓ | ✓ |
| Low power loss | <ul style="list-style-type: none"> Reduces power consumption and energy costs (up 98% less power is used than for thermal overload relays). Minimizes temperature rises of the contactor and controlgear cabinet – in some cases this may eliminate the need for controlgear cabinet cooling. Direct mounting to contactor saves space, even for high motor currents (i.e. no heat decoupling is required). | -- | ✓ | ✓ |

1) Exception: up to size S3, only stand-alone installation is possible.



2) Alternatively available for screw connection.

| Features | Benefits | 3RU11 | 3RB20/3RB21 | 3RB22/3RB23 |
|--|--|-------|-------------------|-------------|
|  | | | | |
| Other features | | | | |
| Internal power supply | <ul style="list-style-type: none"> Eliminates the need for configuration and connecting an additional control circuit | -- 1) | ✓ | -- |
| Variable adjustment of the trip classes (The required trip class can be adjusted by means of a rotary knob depending on the current starting condition.) | <ul style="list-style-type: none"> Reduces the number of variants Minimizes the configuring outlay and costs Minimizes storage overhead, storage costs, and tied-up capital | -- | ✓ (only 3RB21) | ✓ |
| Overload warning | <ul style="list-style-type: none"> Indicates imminent tripping of the relay directly on the device due to overload, phase unbalance or phase failure Allows the imminent tripping of the relay to be signaled Allows measures to be taken in time in the event of continuous current-dependent overloads Eliminates the need for an additional device Saves space in the controlgear cabinet Reduces wiring overhead and costs | -- | -- | ✓ |
| Analog output | <ul style="list-style-type: none"> Allows the output of an analog output signal for actuating moving-coil instruments, feeding programmable logic controllers or transfer to bus systems Eliminates the need for an additional measuring transformer and signal converter Saves space in the controlgear cabinet Reduces wiring overhead and costs | -- | -- | ✓ |

1) The SIRIUS 3RU11 thermal overload relays use a bimetal contactor and therefore do not require an additional control circuit.

Overload Relays

General data

| Overload relays | Current measurement | Current range | Contactors (type, size, rating in kW) | | | | | | | |
|--|-----------------------|---------------|---------------------------------------|------------------|------------------|----------------|----------------|--------------------|----------------|--------------------|
| | | | 3RT10 1 | 3RT10 2 | 3RT10 3 | 3RT10 4 | 3RT10 5 | 3RT10 6 | 3RT10 7 | 3TF68/69 |
| Type | Type | A | S00 3/4/5.5 | S0 5.5/7.5/11 | S2 15/18.5/22 | S3 30/37/45 | S6 55/75/90 | S10 110/132/160 | S12 200/250 | Size 14 375/450 |
| 3RU11 thermal overload relays | | | | | | | | | | |
|  | 3RU11 1 | Integrated | 0.11 ... 12 | ✓ | | | | | | |
| | 3RU11 2 | | 1.8 ... 25 | | ✓ | | | | | |
| | 3RU11 3 | | 5.5 ... 50 | | | ✓ | | | | |
| | 3RU11 4 | | 18 ... 100 | | | | ✓ | | | |
| 3RB20/3RB21¹⁾ solid-state overload relays | | | | | | | | | | |
|  | 3RB2. 1 | Integrated | 0.1 ... 12 | ✓ | | | | | | |
| | 3RB2. 2 | | 3 ... 25 | | ✓ | | | | | |
| | 3RB2. 3 | | 6 ... 50 | | | ✓ | | | | |
| | 3RB2. 4 | | 12,5 ... 100 | | | | ✓ | | | |
| | 3RB2. 5 | | 50 ... 200 | | | | | ✓ | | |
| | 3RB2. 6 | | 55 ... 630 | | | | | | ✓ | ✓ |
| 3RB22/3RB23¹⁾ solid-state overload relays | | | | | | | | | | |
|  | 3RB22/3RB23 + 3RB29 0 | | 0.3 ... 25 | ✓ | ✓ | | | | | |
| | 3RB29 0 | | 10 ... 100 | | | ✓ | ✓ | | | |
| | 3RB29 5 | | 20 ... 200 | | | | | ✓ | | |
| | 3RB29 6 | | 63 ... 630 | | | | | | ✓ | ✓ |
| | 3RB29 0 + 3UF18 | | 630 ... 820 | | | | | | | ✓ |

1) When using the overload relays with trip class \geq CLASS 20, see Technical Specifications, Short-Circuit Protection with Fuses for Motor Feeders, and the configuring aid "Configuring SIRIUS Fuseless Load Feeders".

Overload Relays

3RB2 Solid-State Overload Relays

3RB20, 3RB21 for standard applications

Overview

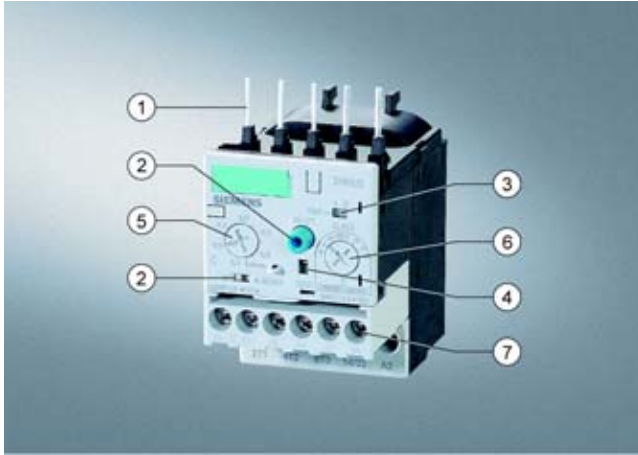

- (1) Connection for mounting onto contactors:
Optimally adapted in electrical, mechanical and design terms to the contactors and soft starters, these connecting pins can be used for direct mounting of the overload relays. Stand-alone installation is possible as an alternative (in some cases in conjunction with a stand-alone installation module).
- (2) Selector switch for manual/automatic RESET and RESET button:
With the slide switch you can choose between manual and automatic RESET. A device set to manual RESET can be reset locally by pressing the RESET button. On the 3RB21 a solid-state remote RESET is integrated.
- (3) Switch position indicator and TEST function of the wiring:
Indicates a trip and enables the wiring test.
- (4) Solid-state test:
Enables a test of all important device components and functions.
- (5) Motor current setting:
Setting the device to the rated motor current is easy with the large rotary knob.
- (6) Trip class setting/internal ground-fault detection (only 3RB21):
Using the rotary switch you can set the required trip class and activate the internal ground-fault detection dependent on the starting conditions.
- (7) Connecting terminals (removable terminal block for auxiliary circuits):
The generously sized terminals permit connection of two conductors with different cross-sections for the main and auxiliary circuits. The auxiliary circuit can be connected with screw-type terminals and alternatively with spring-loaded terminals.

The 3RB20 and 3RB21 solid-state overload relays up to 630 A with internal power supply have been designed for current-dependent protection of loads with normal and heavy starting (see LV 1 T, Function) against excessive temperature rises due to overload, phase unbalance or phase failure. An overload, phase unbalance or phase failure result in an increase of the motor current beyond the set motor rated current. This current rise is detected by the current transformers integrated into the devices and evaluated by corresponding solid-state circuits which then output a pulse to the auxiliary contacts. The auxiliary contacts then switch off the load by means of a contactor. The break time depends on the ratio between the tripping current and set current I_e and is stored in the form of a long-term stable tripping characteristic (see LV 1 T, Characteristic Curves).

In addition to current-dependent protection of loads against excessive temperature rises due to overload, phase unbalance and phase failure, the 3RB21 solid-state overload relays also allow internal ground-fault detection (not possible in conjunction with wye-delta assemblies). This provides protection of loads against high-resistance short-circuits due to damage to the insulation material, moisture, condensed water etc.

The "tripped" status is signaled by means of a switch position indicator (see LV 1 T, Function). Resetting takes place either manually or automatically after the recovery time has elapsed (see LV 1 T, Function).

The devices are manufactured in accordance with environmental guidelines and contain environmentally friendly and reusable materials. They comply with all important worldwide standards and approvals.

Benefits

The most important features and benefits of the 3RB20/3RB21 solid-state overload relays are listed in the overview table (see Overload Relays, General Data).

Overload Relays

3RB2 Solid-State Overload Relays

3RB20, 3RB21 for standard applications

Application

Industries

The 3RB20/3RB21 solid-state overload relays are suitable for customers from all industries who want to guarantee optimum inverse-time delayed protection of their electrical loads (e.g. motors) under normal and heavy starting conditions (CLASS 5 to CLASS 30), minimize project completion times, inventories and power consumption, and optimize plant availability and maintenance management.

Application

The 3RB20/3RB21 solid-state overload relays have been designed for the protection of three-phase motors in sinusoidal 50/60 Hz voltage networks. The relays are not suitable for the protection of single-phase AC or DC loads.

The 3RU11 thermal overload relay or the 3RB22/3RB23 solid-state overload relay can be used for single-phase AC loads. For DC loads we recommend the 3RU11 thermal overload relay.

Ambient conditions

The devices are insensitive to external influences such as shocks, corrosive environments, ageing and temperature changes.

For the temperature range from -25 °C to $+60\text{ °C}$, the 3RB20/3RB21 solid-state overload relays compensate the temperature according to IEC 60947-4-1.

Configuration notes for use of the devices below -25 °C or above $+60\text{ °C}$ on request.

"Increased safety" type of protection EEx e according to ATEX guideline 94/9/EC

The 3RB20/3RB21 solid-state overload relays are suitable for the overload protection of explosion-proof motors with "increased safety" type of protection EEx e. The relays meet the requirements of EN 60079-7 (Electrical apparatus for potentially explosive atmospheres – Increased safety "e").

The basic safety and health requirements of ATEX guideline 94/9/EG are fulfilled by compliance with

- EN 60947-1
- EN 60947-4-1
- EN 60947-5-1
- EN 60079-14

EU type test certificate for Group II, Category (2) G/D under application. Number on request.

Accessories

The following accessories are available for the 3RB20/3RB21 solid-state overload relays:

- One terminal bracket each for the overload relays size S00 and S0 (sizes S2 to S12 can be installed as single units without a terminal bracket)
- One mechanical remote RESET module for all sizes
- One cable release for resetting devices which are difficult to access (for all sizes)
- One sealable cover for all sizes
- Box terminals for sizes S6 and S10/S12
- Terminal covers for sizes S2 to S10/S12

Overload Relays

3RB2 Solid-State Overload Relays

3RB20, 3RB21 for standard applications

Selection and ordering data

Conversion aid 3RB10 → 3RB20

| Size | Old Order No. | Setting range A | New Order No. | Setting range A | |
|---------|----------------------|--------------------|----------------------|----------------------|----------|
| S00 | 3RB10 16-□RB0 | 0.1 ... 0.4 | 3RB20 16-□RB0 | 0.1 ... 0.4 | |
| | 3RB10 16-□NB0 | 0.4 ... 1.6 | 3RB20 16-□NB0 | 0.32 ... 1.25 | |
| | 3RB10 16-□PB0 | 1.5 ... 6 | 3RB20 16-□PB0 | 1 ... 4 | |
| | 3RB10 16-□SB0 | 3 ... 12 | 3RB20 16-□SB0 | 3 ... 12 | |
| S0 | 3RB10 26-□RB0 | 0.1 ... 0.4 | Use size S00 | | |
| | 3RB10 26-□NB0 | 0.4 ... 1.6 | | | |
| | 3RB10 26-□PB0 | 1.5 ... 6 | | | |
| | 3RB10 26-□SB0 | 3 ... 12 | | 3RB20 26-□SB0 | 3 ... 12 |
| | 3RB10 26-□QB0 | 6 ... 25 | | 3RB20 26-□QB0 | 6 ... 25 |
| S2 | 3RB10 36-□QB0 | 6 ... 25 | 3RB20 36-□QB0 | 6 ... 25 | |
| | 3RB10 36-□UB0 | 13 ... 50 | 3RB20 36-□UB0 | 12.5 ... 50 | |
| S3 | 3RB10 46-□UB0 | 13 ... 50 | 3RB20 46-□UB0 | 12.5 ... 50 | |
| | 3RB10 46-□EB0 | 25 ... 100 | 3RB20 46-□EB0 | 25 ... 100 | |
| S6 | 3RB10 56-□FW0 | 50 ... 200 | 3RB20 56-□FW2 | 50 ... 200 | |
| | 3RB10 56-□FG0 | | 3RB20 56-□FC2 | | |
| S10/S12 | 3RB10 66-□GG0 | 55 ... 250 | 3RB20 66-□GC2 | 55 ... 250 | |
| | 3RB10 66-□KG0 | 200 ... 540 | 3RB20 66-□MC2 | 160 ... 630 | |
| | 3RB10 66-□LG0 | 300 ... 630 | | | |

CLASS 10
CLASS 20

1
2

1
2

Conversion aid 3RB10 → 3RB21

| Size | Old Order No. | Setting range A | New Order No. | Setting range A | |
|---------|----------------------|--------------------|----------------------|----------------------|----------|
| S00 | 3RB10 16-□RB0 | 0.1 ... 0.4 | 3RB21 13-4RB0 | 0.1 ... 0.4 | |
| | 3RB10 16-□NB0 | 0.4 ... 1.6 | 3RB21 13-4NB0 | 0.32 ... 1.25 | |
| | 3RB10 16-□PB0 | 1.5 ... 6 | 3RB21 13-4PB0 | 1 ... 4 | |
| | 3RB10 16-□SB0 | 3 ... 12 | 3RB21 13-4SB0 | 3 ... 12 | |
| S0 | 3RB10 26-□RB0 | 0.1 ... 0.4 | Use size S00 | | |
| | 3RB10 26-□NB0 | 0.4 ... 1.6 | | | |
| | 3RB10 26-□PB0 | 1.5 ... 6 | | | |
| | 3RB10 26-□SB0 | 3 ... 12 | | 3RB21 23-4SB0 | 3 ... 12 |
| | 3RB10 26-□QB0 | 6 ... 25 | | 3RB21 23-4QB0 | 6 ... 25 |
| S2 | 3RB10 36-□QB0 | 6 ... 25 | 3RB21 33-4QB0 | 6 ... 25 | |
| | 3RB10 36-□UB0 | 13 ... 50 | 3RB21 33-4UB0 | 12.5 ... 50 | |
| S3 | 3RB10 46-□UB0 | 13 ... 50 | 3RB21 43-4UB0 | 12.5 ... 50 | |
| | 3RB10 46-□EB0 | 25 ... 100 | 3RB21 43-4EB0 | 25 ... 100 | |
| S6 | 3RB10 56-□FW0 | 50 ... 200 | 3RB21 53-4FW2 | 50 ... 200 | |
| | 3RB10 56-□FG0 | | 3RB21 53-4FC2 | | |
| S10/S12 | 3RB10 66-□GG0 | 55 ... 250 | 3RB21 63-4GC2 | 55 ... 250 | |
| | 3RB10 66-□KG0 | 200 ... 540 | 3RB21 63-4MC2 | 160 ... 630 | |
| | 3RB10 66-□LG0 | 300 ... 630 | | | |

CLASS 10
CLASS 20

1
2

Note:

CLASS 5, 10, 20 and 30
can be set on the unit

Overload Relays







3RB2 Solid-State Overload Relays

3RB20, 3RB21 for standard applications

3RB20 solid-state overload relays with screw connection on auxiliary current side for direct mounting¹⁾²⁾ and stand-alone installation²⁾³⁾, CLASS 10

Features and technical specifications:

- Overload protection, phase failure protection and unbalance protection
- Internal power supply
- Auxiliary contacts 1 NO + 1 NC
- Manual and automatic RESET
- Switch position indicator
- TEST function and self-monitoring

| Size Con- tactor ⁴⁾ | Rating for induction motor Rated value ⁵⁾ | Set current value of the inverse- time delayed overload trip | Short-circuit protection with fuse, type of coordination 2, gL/gG operational class ⁶⁾ | DT | Order No. | Price per PU | PU (UNIT, SET, M) | PS* | PG | Weight per PU approx. |
|---|---|---|--|-----|------------------------|-----------------|-------------------------|--------|-----|-----------------------------|
| | kW | A | A | | | | | | | kg |
| Size S00¹⁾ | | | | | | | | | | |
|  | S00 | 0.04 ... 0.09 | 0.1 ... 0.4 | 2 | ▶ 3RB20 16-1RB0 | | 1 | 1 unit | 101 | 0.200 |
| | | 0.12 ... 0.37 | 0.32 ... 1.25 | 6 | ▶ 3RB20 16-1NB0 | | 1 | 1 unit | 101 | 0.200 |
| | | 0.55 ... 1.5 | 1 ... 4 | 20 | ▶ 3RB20 16-1PB0 | | 1 | 1 unit | 101 | 0.200 |
| | | 1.1 ... 5.5 | 3 ... 12 | 35 | ▶ 3RB20 16-1SB0 | | 1 | 1 unit | 101 | 0.200 |
| Size S0¹⁾ | | | | | | | | | | |
|  | S0 | 1.1 ... 5.5 | 3 ... 12 | 35 | ▶ 3RB20 26-1SB0 | | 1 | 1 unit | 101 | 0.220 |
| | | 3 ... 11 | 6 ... 25 | | ▶ 3RB20 26-1QB0 | | 1 | 1 unit | 101 | 0.220 |
| Size S2¹⁾³⁾⁷⁾ | | | | | | | | | | |
|  | S2 | 3 ... 11 | 6 ... 25 | 35 | ▶ 3RB20 36-1QB0 | | 1 | 1 unit | 101 | 0.360 |
| | | | | | ▶ 3RB20 36-1QW1 | | 1 | 1 unit | 101 | 0.230 |
| | | 7.5 ... 22 | 12.5 ... 50 | 100 | ▶ 3RB20 36-1UB0 | | 1 | 1 unit | 101 | 0.360 |
| | | | | | ▶ 3RB20 36-1UW1 | | 1 | 1 unit | 101 | 0.230 |
| Size S3¹⁾³⁾⁷⁾ | | | | | | | | | | |
|  | S3 | 7.5 ... 22 | 12.5 ... 50 | 125 | ▶ 3RB20 46-1UB0 | | 1 | 1 unit | 101 | 0.560 |
| | | | | | ▶ 3RB20 46-1EB0 | | 1 | 1 unit | 101 | 0.560 |
| | | 11 ... 45 | 25 ... 100 | 200 | ▶ 3RB20 46-1EW1 | | 1 | 1 unit | 101 | 0.450 |
| Size S6²⁾⁷⁾ | | | | | | | | | | |
|  | S6 | 22 ... 90 | 50 ... 200 | 355 | ▶ 3RB20 56-1FC2 | | 1 | 1 unit | 101 | 1.030 |
| | | | | | ▶ 3RB20 56-1FW2 | | 1 | 1 unit | 101 | 0.690 |
| Size S10/S12²⁾ | | | | | | | | | | |
|  | S10/S12 and size 14 (3TF68/ 3TF69) | 22 ... 110 | 55 ... 250 | 500 | ▶ 3RB20 66-1GC2 | | 1 | 1 unit | 101 | 1.820 |
| | | 90 ... 450 | 160 ... 630 | 800 | ▶ 3RB20 66-1MC2 | | 1 | 1 unit | 101 | 1.820 |

1) The relays with an Order No. ending with "0" are designed for direct mounting. With the matching terminal brackets (see Accessories) the sizes S00 and S0 can also be installed as stand-alone units.

2) The relays with an Order No. ending with "2" are designed for direct mounting and stand-alone installation. For 3TF68/3TF69 contactors, direct mounting is not possible.

3) The relays with an Order No. ending with "1" are designed for stand-alone installation.

4) Observe maximum rated operational current of the devices.

5) Standard value for 4-pole standard motors at 50 Hz 400 V AC. The actual starting and rated data of the motor to be protected must be considered when selecting the units.

6) Maximum fuse for overload relay, type of coordination 2. For fuse values in conjunction with contactors, see Technical Specifications, Short-Circuit Protection with Fuses for Motor Feeders.

7) The relays with an Order No. with "W" in penultimate position are equipped with a straight-through transformer.

Overload Relays







3RB2 Solid-State Overload Relays

3RB20, 3RB21 for standard applications

3RB20 solid-state overload relays with spring-loaded terminals on the auxiliary current side for direct mounting¹⁾²⁾ and stand-alone installation²⁾³⁾, CLASS 10

Features and technical specifications:

- Overload protection, phase failure protection and unbalance protection
- Internal power supply
- Auxiliary contacts 1 NO + 1 NC
- Manual and automatic RESET
- Switch position indicator
- TEST function and self-monitoring

| Size Con- tactor ⁴⁾ | Rating for induction motor Rated value ⁵⁾ | Set current value of the inverse- time delayed overload trip | Short-circuit protection with fuse, type of coordi- nation 2, gL/gG operational class ⁶⁾ | DT | Order No. | Price per PU | PU (UNIT, SET, M) | PS* | PG | Weight per PU approx. |
|---|---|---|--|-----|-----------|----------------------|-------------------------|-----|--------|-----------------------------|
| | | | | | | | | | | |
| Size S00¹⁾ | | | | | | | | | | |
|  | S00 | 0.04 ... 0.09 | 0.1 ... 0.4 | 2 | A | 3RB20 16-1RDO | | 1 | 1 unit | 101 0.200 |
| | | 0.12 ... 0.37 | 0.32 ... 1.25 | 6 | A | 3RB20 16-1NDO | | 1 | 1 unit | 101 0.200 |
| | | 0.55 ... 1.5 | 1 ... 4 | 20 | A | 3RB20 16-1PDO | | 1 | 1 unit | 101 0.200 |
| | | 1.1 ... 5.5 | 3 ... 12 | 35 | A | 3RB20 16-1SDO | | 1 | 1 unit | 101 0.200 |
| 3RB20 16-1RDO | | | | | | | | | | |
| Size S0¹⁾ | | | | | | | | | | |
|  | S0 | 1.1 ... 5.5 | 3 ... 12 | 35 | A | 3RB20 26-1SDO | | 1 | 1 unit | 101 0.220 |
| | | 3 ... 11 | 6 ... 25 | | A | 3RB20 26-1QDO | | 1 | 1 unit | 101 0.220 |
| 3RB20 26-1QDO | | | | | | | | | | |
| Size S2¹⁾³⁾⁷⁾ | | | | | | | | | | |
|  | S2 | 3 ... 11 | 6 ... 25 | 35 | A | 3RB20 36-1QDO | | 1 | 1 unit | 101 0.360 |
| | | | | | A | 3RB20 36-1QX1 | | 1 | 1 unit | 101 0.230 |
| | | 7.5 ... 22 | 12.5 ... 50 | 100 | A | 3RB20 36-1UD0 | | 1 | 1 unit | 101 0.360 |
| | | | | | A | 3RB20 36-1UX1 | | 1 | 1 unit | 101 0.230 |
| 3RB20 36-1UD0 | | | | | | | | | | |
| Size S3¹⁾³⁾⁷⁾ | | | | | | | | | | |
|  | S3 | 7.5 ... 22 | 12.5 ... 50 | 125 | A | 3RB20 46-1UD0 | | 1 | 1 unit | 101 0.560 |
| | | 11 ... 45 | 25 ... 100 | 200 | A | 3RB20 46-1ED0 | | 1 | 1 unit | 101 0.560 |
| | | | | | A | 3RB20 46-1EX1 | | 1 | 1 unit | 101 0.450 |
| 3RB20 46-1ED0 | | | | | | | | | | |
| Size S6²⁾⁷⁾ | | | | | | | | | | |
|  | S6 | 22 ... 90 | 50 ... 200 | 355 | A | 3RB20 56-1FF2 | | 1 | 1 unit | 101 1.030 |
| | | | | | A | 3RB20 56-1FX2 | | 1 | 1 unit | 101 0.690 |
| 3RB20 56-1FX2 | | | | | | | | | | |
| Size S10/S12²⁾ | | | | | | | | | | |
|  | S10/S12 and size 14 (3TF68/ 3TF69) | 22 ... 110 | 55 ... 250 | 500 | A | 3RB20 66-1GF2 | | 1 | 1 unit | 101 1.820 |
| | | 90 ... 450 | 160 ... 630 | 800 | A | 3RB20 66-1MF2 | | 1 | 1 unit | 101 1.820 |
| 3RB20 66-1MF2 | | | | | | | | | | |

1) The relays with an Order No. ending with "0" are designed for direct mounting. With the matching terminal brackets (see Accessories) the sizes S00 and S0 can also be installed as stand-alone units.

2) The relays with an Order No. ending with "2" are designed for direct mounting and stand-alone installation. For 3TF68/3TF69 contactors, direct mounting is not possible.

3) The relays with an Order No. ending with "1" are designed for stand-alone installation.

4) Observe maximum rated operational current of the devices.

5) Standard value for 4-pole standard motors at 50 Hz 400 V AC. The actual starting and rated data of the motor to be protected must be considered when selecting the units.

6) Maximum fuse for overload relay, type of coordination 2. For fuse values in conjunction with contactors, see Technical Specifications, Short-Circuit Protection with Fuses for Motor Feeders.

7) The relays with an Order No. with "X" in penultimate position are equipped with a straight-through transformer.

* You can order this quantity or a multiple thereof.

Overload Relays







3RB2 Solid-State Overload Relays

3RB20, 3RB21 for standard applications

3RB20 solid-state overload relays with screw connection on auxiliary current side for direct mounting¹⁾²⁾ and stand-alone installation²⁾³⁾, CLASS 20

Features and technical specifications:

- Overload protection, phase failure protection and unbalance protection
- Internal power supply
- Auxiliary contacts 1 NO + 1 NC
- Manual and automatic RESET
- Switch position indicator
- TEST function and self-monitoring

| Size Con- tactor ⁴⁾ | Rating for induction motor Rated value ⁵⁾ | Set current value of the inverse- time delayed overload trip | Short-circuit protection with fuse, type of coordi- nation 2, gL/gG operational class ⁶⁾ | DT | With screw connection on auxiliary current side | | PU (UNIT, SET, M) | PS* | PG | Weight per PU approx. | |
|---|---|---|--|-----|--|----------------------|-------------------------|-----|--------|-----------------------------|-------|
| | | | | | Order No. | Price per PU | | | | | |
| | kW | A | A | | | | | | | kg | |
| Size S00¹⁾ | | | | | | | | | | | |
|  | S00 | 0.04 ... 0.09 | 0.1 ... 0.4 | 2 | ▶ | 3RB20 16-2RB0 | | 1 | 1 unit | 101 | 0.200 |
| | | 0.12 ... 0.37 | 0.32 ... 1.25 | 6 | ▶ | 3RB20 16-2NB0 | | 1 | 1 unit | 101 | 0.200 |
| | | 0.55 ... 1.5 | 1 ... 4 | 20 | ▶ | 3RB20 16-2PB0 | | 1 | 1 unit | 101 | 0.200 |
| | | 1.1 ... 5.5 | 3 ... 12 | 35 | ▶ | 3RB20 16-2SB0 | | 1 | 1 unit | 101 | 0.200 |
| Size S0¹⁾ | | | | | | | | | | | |
|  | S0 | 1.1 ... 5.5 | 3 ... 12 | 35 | ▶ | 3RB20 26-2SB0 | | 1 | 1 unit | 101 | 0.220 |
| | | 3 ... 11 | 6 ... 25 | | ▶ | 3RB20 26-2QB0 | | 1 | 1 unit | 101 | 0.220 |
| Size S2¹⁾³⁾⁷⁾ | | | | | | | | | | | |
|  | S2 | 3 ... 11 | 6 ... 25 | 35 | ▶ | 3RB20 36-2QB0 | | 1 | 1 unit | 101 | 0.360 |
| | | | | | ▶ | 3RB20 36-2QW1 | | 1 | 1 unit | 101 | 0.230 |
| | | 7.5 ... 22 | 12.5 ... 50 | 100 | ▶ | 3RB20 36-2UB0 | | 1 | 1 unit | 101 | 0.360 |
| Size S3¹⁾³⁾⁷⁾ | | | | | | | | | | | |
|  | S3 | 7.5 ... 22 | 12.5 ... 50 | 125 | ▶ | 3RB20 46-2UB0 | | 1 | 1 unit | 101 | 0.560 |
| | | | | | ▶ | 3RB20 46-2EB0 | | 1 | 1 unit | 101 | 0.560 |
| | | 11 ... 45 | 25 ... 100 | 200 | ▶ | 3RB20 46-2EW1 | | 1 | 1 unit | 101 | 0.450 |
| Size S6²⁾⁷⁾ | | | | | | | | | | | |
|  | S6 | 22 ... 90 | 50 ... 200 | 355 | ▶ | 3RB20 56-2FC2 | | 1 | 1 unit | 101 | 1.030 |
| | | | | | ▶ | 3RB20 56-2FW2 | | 1 | 1 unit | 101 | 0.690 |
| Size S10/S12²⁾ | | | | | | | | | | | |
|  | S10/S12 and size 14 (3TF68/ 3TF69) | 22 ... 110 | 55 ... 250 | 500 | ▶ | 3RB20 66-2GC2 | | 1 | 1 unit | 101 | 1.820 |
| | | 90 ... 450 | 160 ... 630 | 800 | ▶ | 3RB20 66-2MC2 | | 1 | 1 unit | 101 | 1.820 |

1) The relays with an Order No. ending with "0" are designed for direct mounting. With the matching terminal brackets (see Accessories) the sizes S00 and S0 can also be installed as stand-alone units.

2) The relays with an Order No. ending with "2" are designed for direct mounting and stand-alone installation. For 3TF68/3TF69 contactors, direct mounting is not possible.

3) The relays with an Order No. ending with "1" are designed for stand-alone installation.

4) Observe maximum rated operational current of the devices.

5) Standard value for 4-pole standard motors at 50 Hz 400 V AC. The actual starting and rated data of the motor to be protected must be considered when selecting the units.

6) Maximum fuse for overload relay, type of coordination 2. For fuse values in conjunction with contactors, see Technical Specifications, Short-Circuit Protection with Fuses for Motor Feeders.

7) The relays with an Order No. with "W" in penultimate position are equipped with a straight-through transformer.

Overload Relays







3RB2 Solid-State Overload Relays

3RB20, 3RB21 for standard applications

3RB20 solid-state overload relays with spring-loaded terminals on the auxiliary current side for direct mounting¹⁾²⁾ and stand-alone installation²⁾³⁾, CLASS 20

Features and technical specifications:

- Overload protection, phase failure protection and unbalance protection
- Internal power supply
- Auxiliary contacts 1 NO + 1 NC
- Manual and automatic RESET
- Switch position indicator
- TEST function and self-monitoring

| Size Con- tactor ⁴⁾ | Rating for induction motor Rated value ⁵⁾ | Set current value of the inverse- time delayed overload trip | Short-circuit protection with fuse, type of coordi- nation 2, gL/gG operational class ⁶⁾ | DT | With spring-loaded terminals on auxiliary current side | | PU (UNIT, SET, M) | PS* | PG | Weight per PU approx. | |
|---|---|---|--|-----|--|----------------------|-------------------------|-----|--------|-----------------------------|-------|
| | | | | | Order No. | Price per PU | | | | | |
| | kW | A | A | | | | | | | kg | |
| Size S00¹⁾ | | | | | | | | | | | |
|  | S00 | 0.04 ... 0.09 | 0.1 ... 0.4 | 2 | A | 3RB20 16-2RDO | | 1 | 1 unit | 101 | 0.200 |
| | | 0.12 ... 0.37 | 0.32 ... 1.25 | 6 | A | 3RB20 16-2NDO | | 1 | 1 unit | 101 | 0.200 |
| | | 0.55 ... 1.5 | 1 ... 4 | 20 | A | 3RB20 16-2PDO | | 1 | 1 unit | 101 | 0.200 |
| | | 1.1 ... 5.5 | 3 ... 12 | 35 | A | 3RB20 16-2SDO | | 1 | 1 unit | 101 | 0.200 |
| 3RB20 16-2RDO | | | | | | | | | | | |
| Size S0¹⁾ | | | | | | | | | | | |
|  | S0 | 1.1 ... 5.5 | 3 ... 12 | 35 | A | 3RB20 26-2SDO | | 1 | 1 unit | 101 | 0.220 |
| | | 3 ... 11 | 6 ... 25 | | A | 3RB20 26-2QD0 | | 1 | 1 unit | 101 | 0.220 |
| 3RB20 26-2QD0 | | | | | | | | | | | |
| Size S2¹⁾³⁾⁷⁾ | | | | | | | | | | | |
|  | S2 | 3 ... 11 | 6 ... 25 | 35 | A | 3RB20 36-2QX1 | | 1 | 1 unit | 101 | 0.230 |
| | | | | | A | 3RB20 36-2QD0 | | 1 | 1 unit | 101 | 0.360 |
| | | 7.5 ... 22 | 12.5 ... 50 | 100 | A | 3RB20 36-2UD0 | | 1 | 1 unit | 101 | 0.360 |
| | | | | | A | 3RB20 36-2UX1 | | 1 | 1 unit | 101 | 0.230 |
| 3RB20 36-2UD0 | | | | | | | | | | | |
| Size S3¹⁾³⁾⁷⁾ | | | | | | | | | | | |
|  | S3 | 7.5 ... 22 | 12.5 ... 50 | 125 | A | 3RB20 46-2UD0 | | 1 | 1 unit | 101 | 0.560 |
| | | 11 ... 45 | 25 ... 100 | 200 | A | 3RB20 46-2ED0 | | 1 | 1 unit | 101 | 0.560 |
| | | | | | A | 3RB20 46-2EX1 | | 1 | 1 unit | 101 | 0.450 |
| 3RB20 46-2ED0 | | | | | | | | | | | |
| Size S6²⁾⁷⁾ | | | | | | | | | | | |
|  | S6 | 22 ... 90 | 50 ... 200 | 355 | A | 3RB20 56-2FF2 | | 1 | 1 unit | 101 | 1.030 |
| | | | | | A | 3RB20 56-2FX2 | | 1 | 1 unit | 101 | 0.690 |
| 3RB20 56-2FX2 | | | | | | | | | | | |
| Size S10/S12²⁾ | | | | | | | | | | | |
|  | S10/S12 and size 14 (3TF68/ 3TF69) | 22 ... 110 | 55 ... 250 | 500 | A | 3RB20 66-2GF2 | | 1 | 1 unit | 101 | 1.820 |
| | | 90 ... 450 | 160 ... 630 | 800 | A | 3RB20 66-2MF2 | | 1 | 1 unit | 101 | 1.820 |
| 3RB20 66-2MF2 | | | | | | | | | | | |

1) The relays with an Order No. ending with "0" are designed for direct mounting. With the matching terminal brackets (see Accessories) the sizes S00 and S0 can also be installed as stand-alone units.

2) The relays with an Order No. ending with "2" are designed for direct mounting and stand-alone installation. For 3TF68/3TF69 contactors, direct mounting is not possible.

3) The relays with an Order No. ending with "1" are designed for stand-alone installation.

4) Observe maximum rated operational current of the devices.

5) Standard value for 4-pole standard motors at 50 Hz 400 V AC. The actual starting and rated data of the motor to be protected must be considered when selecting the units.

6) Maximum fuse for overload relay, type of coordination 2. For fuse values in conjunction with contactors, see Technical Specifications, Short-Circuit Protection with Fuses for Motor Feeders.

7) The relays with an Order No. with "X" in penultimate position are equipped with a straight-through transformer.

* You can order this quantity or a multiple thereof.

Overload Relays







3RB2 Solid-State Overload Relays

3RB20, 3RB21 for standard applications

3RB21 solid-state overload relays with screw connection on auxiliary current side for direct mounting¹⁾²⁾ and stand-alone installation²⁾³⁾, CLASS 5, 10, 20 and 30 adjustable

Features and technical specifications:

- Overload protection, phase failure protection and unbalance protection
- Internal ground fault detection (activatable)
- Internal power supply
- Auxiliary contacts 1 NO + 1 NC
- Manual and automatic RESET
- Electrical remote RESET integrated
- Switch position indicator
- TEST function and self-monitoring

| Size Con-tactor ⁴⁾ | Rating for induction motor Rated value ⁵⁾ | Set current value of the inverse-time delayed overload trip | Short-circuit protection with fuse, type of coordination 2, gL/gG operational class ⁶⁾ | DT | With screw connection on auxiliary current side | | PU (UNIT, SET, M) | PS* | PG | Weight per PU approx. | |
|---|--|---|---|-----|---|----------------------|-------------------|--------|--------|-----------------------|-------|
| | | | | | Order No. | Price per PU | | | | | |
| | kW | A | A | | | | | | | kg | |
| Size S00¹⁾ | | | | | | | | | | | |
|  | S00 | 0.04 ... 0.09 | 0.1 ... 0.4 | 2 | ▶ | 3RB21 13-4RB0 | | 1 | 1 unit | 101 | 0.200 |
| | | 0.12 ... 0.37 | 0.32 ... 1.25 | 6 | ▶ | 3RB21 13-4NB0 | | 1 | 1 unit | 101 | 0.200 |
| | | 0.55 ... 1.5 | 1 ... 4 | 20 | ▶ | 3RB21 13-4PB0 | | 1 | 1 unit | 101 | 0.200 |
| | | 1.1 ... 5.5 | 3 ... 12 | 35 | ▶ | 3RB21 13-4SB0 | | 1 | 1 unit | 101 | 0.200 |
| 3RB21 13-4RB0 | | | | | | | | | | | |
| Size S0¹⁾ | | | | | | | | | | | |
|  | S0 | 1.1 ... 5.5 | 3 ... 12 | 35 | ▶ | 3RB21 23-4SB0 | | 1 | 1 unit | 101 | 0.220 |
| | | 3 ... 11 | 6 ... 25 | | ▶ | 3RB21 23-4QB0 | | 1 | 1 unit | 101 | 0.220 |
| 3RB21 23-4QB0 | | | | | | | | | | | |
| Size S2¹⁾³⁾⁷⁾ | | | | | | | | | | | |
|  | S2 | 3 ... 11 | 6 ... 25 | 35 | ▶ | 3RB21 33-4QB0 | | 1 | 1 unit | 101 | 0.360 |
| | | | | | ▶ | 3RB21 33-4QW1 | | 1 | 1 unit | 101 | 0.230 |
| | | 7.5 ... 22 | 12.5 ... 50 | 100 | ▶ | 3RB21 33-4UB0 | | 1 | 1 unit | 101 | 0.360 |
| | | | | ▶ | 3RB21 33-4UW1 | | 1 | 1 unit | 101 | 0.230 | |
| 3RB21 33-4UB0 | | | | | | | | | | | |
| Size S3¹⁾³⁾⁷⁾ | | | | | | | | | | | |
|  | S3 | 7.5 ... 22 | 12.5 ... 50 | 125 | ▶ | 3RB21 43-4UB0 | | 1 | 1 unit | 101 | 0.560 |
| | | | | | ▶ | 3RB21 43-4EB0 | | 1 | 1 unit | 101 | 0.560 |
| | | 11 ... 45 | 25 ... 100 | 200 | ▶ | 3RB21 43-4EW1 | | 1 | 1 unit | 101 | 0.450 |
| 3RB21 43-4EB0 | | | | | | | | | | | |
| Size S6²⁾⁷⁾ | | | | | | | | | | | |
|  | S6 | 22 ... 90 | 50 ... 200 | 355 | ▶ | 3RB21 53-4FC2 | | 1 | 1 unit | 101 | 1.030 |
| | | | | | ▶ | 3RB21 53-4FW2 | | 1 | 1 unit | 101 | 0.690 |
| 3RB21 53-4FC2 | | | | | | | | | | | |
| Size S10/S12²⁾ | | | | | | | | | | | |
|  | S10/S12 and size 14 (3TF68/3TF69) | 22 ... 110 | 55 ... 250 | 500 | ▶ | 3RB21 63-4GC2 | | 1 | 1 unit | 101 | 1.820 |
| | | 90 ... 450 | 160 ... 630 | 800 | ▶ | 3RB21 63-4MC2 | | 1 | 1 unit | 101 | 1.820 |
| 3RB21 63-4MC2 | | | | | | | | | | | |

- 1) The relays with an Order No. ending with "0" are designed for direct mounting. With the matching terminal brackets (see Accessories) the sizes S00 and S0 can also be installed as stand-alone units.
- 2) The relays with an Order No. ending with "2" are designed for direct mounting and stand-alone installation. For 3TF68/3TF69 contactors, direct mounting is not possible.
- 3) The relays with an Order No. ending with "1" are designed for stand-alone installation.
- 4) Observe maximum rated operational current of the devices.

- 5) Standard value for 4-pole standard motors at 50 Hz 400 V AC. The actual starting and rated data of the motor to be protected must be considered when selecting the units.
- 6) Maximum fuse for overload relay, type of coordination 2. For fuse values in conjunction with contactors, see Technical Specifications, Short-Circuit Protection with Fuses for Motor Feeders.
- 7) The relays with an Order No. with "W" in penultimate position are equipped with a straight-through transformer.

* You can order this quantity or a multiple thereof.

Overload Relays







3RB2 Solid-State Overload Relays

3RB20, 3RB21 for standard applications

3RB21 solid-state overload relays with spring-loaded terminals on the auxiliary current side for direct mounting¹⁾²⁾ and stand-alone installation¹⁾³⁾, CLASS 5, 10, 20 and 30 adjustable

Features and technical specifications:

- Overload protection, phase failure protection and unbalance protection
- Internal ground fault detection (activatable)
- Internal power supply
- Auxiliary contacts 1 NO + 1 NC
- Manual and automatic RESET
- Electrical remote RESET integrated
- Switch position indicator
- TEST function and self-monitoring

| Size Con-tactor ⁴⁾ | Rating for induction motor Rated value ⁵⁾ | Set current value of the inverse-time delayed overload trip | Short-circuit protection with fuse, type of coordination 2, gL/gG operational class ⁶⁾ | DT | With spring-loaded terminals on auxiliary current side | | PU (UNIT, SET, M) | PS* | PG | Weight per PU approx. | |
|---|--|---|---|-----|--|----------------------|-------------------|-----|--------|-----------------------|-------|
| | | | | | Order No. | Price per PU | | | | | |
| | kW | A | A | | | | | | | kg | |
| Size S00¹⁾ | | | | | | | | | | | |
|  | S00 | 0.04 ... 0.09 | 0.1 ... 0.4 | 2 | A | 3RB21 13-4RD0 | | 1 | 1 unit | 101 | 0.200 |
| | | 0.12 ... 0.37 | 0.32 ... 1.25 | 6 | A | 3RB21 13-4ND0 | | 1 | 1 unit | 101 | 0.200 |
| | | 0.55 ... 1.5 | 1 ... 4 | 20 | A | 3RB21 13-4PD0 | | 1 | 1 unit | 101 | 0.200 |
| | | 1.1 ... 5.5 | 3 ... 12 | 35 | A | 3RB21 13-4SD0 | | 1 | 1 unit | 101 | 0.200 |
| Size S0¹⁾ | | | | | | | | | | | |
|  | S0 | 1.1 ... 5.5 | 3 ... 12 | 35 | A | 3RB21 23-4SD0 | | 1 | 1 unit | 101 | 0.220 |
| | | 3 ... 11 | 6 ... 25 | | A | 3RB21 23-4QD0 | | 1 | 1 unit | 101 | 0.220 |
| Size S2¹⁾³⁾⁷⁾ | | | | | | | | | | | |
|  | S2 | 3 ... 11 | 6 ... 25 | 35 | A | 3RB21 33-4QD0 | | 1 | 1 unit | 101 | 0.360 |
| | | | | | | 3RB21 33-4QX1 | | 1 | 1 unit | 101 | 0.230 |
| | | 7.5 ... 22 | 12.5 ... 50 | 100 | A | 3RB21 33-4UD0 | | 1 | 1 unit | 101 | 0.360 |
| | | | | | | 3RB21 33-4UX1 | | 1 | 1 unit | 101 | 0.230 |
| Size S3¹⁾³⁾⁷⁾ | | | | | | | | | | | |
|  | S3 | 7.5 ... 22 | 12.5 ... 50 | 125 | A | 3RB21 43-4UD0 | | 1 | 1 unit | 101 | 0.560 |
| | | 11 ... 45 | 25 ... 100 | 200 | A | 3RB21 43-4ED0 | | 1 | 1 unit | 101 | 0.560 |
| | | | | | | 3RB21 43-4EX1 | | 1 | 1 unit | 101 | 0.450 |
| Size S6²⁾⁷⁾ | | | | | | | | | | | |
|  | S6 | 22 ... 90 | 50 ... 200 | 355 | A | 3RB21 53-4FF2 | | 1 | 1 unit | 101 | 1.030 |
| | | | | | | 3RB21 53-4FX2 | | 1 | 1 unit | 101 | 0.690 |
| Size S10/S12²⁾ | | | | | | | | | | | |
|  | S10/S12 and size 14 (3TF68/3TF69) | 22 ... 110 | 55 ... 250 | 500 | A | 3RB21 63-4GF2 | | 1 | 1 unit | 101 | 1.820 |
| | | 90 ... 450 | 160 ... 630 | 800 | A | 3RB21 63-4MF2 | | 1 | 1 unit | 101 | 1.820 |

1) The relays with an Order No. ending with "0" are designed for direct mounting. With the matching terminal brackets (see Accessories) the sizes S00 and S0 can also be installed as stand-alone units.

2) The relays with an Order No. ending with "2" are designed for direct mounting and stand-alone installation. For 3TF68/3TF69 contactors, direct mounting is not possible.

3) The relays with an Order No. ending with "1" are designed for stand-alone installation.

4) Observe maximum rated operational current of the devices.

5) Standard value for 4-pole standard motors at 50 Hz 400 V AC. The actual starting and rated data of the motor to be protected must be considered when selecting the units.

6) Maximum fuse for overload relay, type of coordination 2. For fuse values in conjunction with contactors, see Technical Specifications, Short-Circuit Protection with Fuses for Motor Feeders.

7) The relays with an Order No. with "X" in penultimate position are equipped with a straight-through transformer.

* You can order this quantity or a multiple thereof.

Overload Relays

3RB2 Solid-State Overload Relays

3RB22, 3RB23 for high-feature applications

Overview

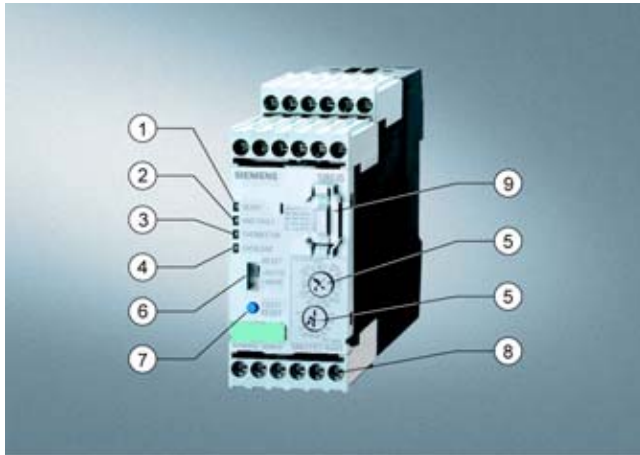

3RB22/3RB23 evaluation module

- (1) Green "Ready" LED
A continuous green light signals that the device is working correctly.
- (2) Red "Ground fault" LED:
A continuous red light signals a ground fault.
- (3) Red "Thermistor" LED:
A continuous red light signals an active thermistor trip.
- (4) Red "Overload" LED:
A continuous red light signals an active overload trip; a flickering red light signals an imminent trip (overload warning).
- (5) Motor current and trip class adjustment:
Setting the device to the motor current and to the required trip class dependent on the starting conditions is easy with the two rotary knobs.
- (6) Selector switch for manual/automatic RESET:
With this switch you can choose between manual and automatic RESET.
- (7) Test/RESET button:
Enables testing of all important device components and functions, plus resetting of the device after a trip when manual RESET is selected.
- (8) Connecting terminals (removable terminal block):
The generously sized terminals permit connection of two conductors with different cross-sections for the auxiliary, control and sensor circuits. Connection is possible with screw-type terminals and alternatively with spring-loaded terminals.
- (9) 3RB29 85 function expansion module:
Enables more functions to be added, e.g. internal ground fault detection and/or an analog output with corresponding signals.



3RB29 06 current measuring module

The modular, solid-state overload relays with external power supply type 3RB22 (with monostable auxiliary contacts) and type 3RB23 (with bistable auxiliary contacts) up to 630 A (up to 820 A possible with a series transformer) have been designed for inverse-time delayed protection of loads with normal and heavy starting (see LV 1 T, Function) against excessive temperature rises due to overload, phase unbalance or phase failure. An overload, phase unbalance or phase failure result in an increase of the motor current beyond the set motor rated current. This current rise is detected by means of a current measuring module and electronically evaluated by a special evaluation module which is connected to it. The evaluation electronics sends a signal to the auxiliary contacts. The auxiliary contacts then switch off the load by means of a contactor. The break time depends on the ratio between the tripping current and set current I_e and is stored in the form of a long-term stable tripping characteristic (see LV 1 T, Characteristic Curves). The "tripped" status is signaled by means of a continuous red "Overload" LED.

The LED indicates imminent tripping of the relay due to overload, phase unbalance or phase failure by flickering when the limit current has been violated. This warning can also be issued as a signal through auxiliary contacts.

In addition to the described inverse-time delayed protection of loads against excessive temperature rises, the 3RB22/3RB23 solid-state overload relays also allow direct temperature monitoring of the motor windings (full motor protection) by failsafe connection of a PTC sensor circuit. With this temperature-dependent protection, the loads can be protected against overheating caused indirectly by reduced coolant flow, for example, which cannot be detected by means of the current alone. In the event of overheating, the devices switch off the contactor, and thus the load, by means of the auxiliary contacts. The "tripped" status is signaled by means of a continuously illuminated "Overload" LED.

To also protect the loads against high-resistance short-circuits due to damage to the insulation, humidity, condensed water, etc., the 3RB22/3RB23 solid-state overload relays offer the possibility of internal ground fault monitoring in conjunction with a function expansion module (for details see Selection and Ordering Data; not possible in conjunction with contactor assembly for Wye-Delta starting). In the event of a ground fault the 3RB22/3RB23 relays trip instantaneously. The "tripped" status is signaled by means of a red "Ground Fault" LED. Signaling through auxiliary contacts is also possible.

After tripping due to overload, phase unbalance, phase failure, thermistor tripping or ground fault, the relay is reset manually or automatically after the recovery time has elapsed (see LV 1 T, Function).

In conjunction with a function expansion module the motor current measured by the microprocessor can be output in the form of an analog signal 4 ... 20 mA DC for operating rotary coil instruments or for feeding into analog inputs of programmable logic controllers. With an additional AS-Interface analog module the current values can also be transferred over the AS-i bus system.

The devices are manufactured in accordance with environmental guidelines and contain environmentally friendly and reusable materials.

They comply with all important worldwide standards and approvals.

Overload Relays

3RB2 Solid-State Overload Relays

3RB22, 3RB23 for high-feature applications

Benefits

The most important features and benefits of the 3RB22/3RB23 solid-state overload relays are listed in the overview table (see [Overload Relays, General Data](#)).

Application

Industries

The 3RB22/3RB23 solid-state overload relays are suitable for customers from all industries who want to guarantee optimum inverse-time delayed and temperature-dependent protection of their electrical loads (e.g. motors) under normal and heavy starting conditions (CLASS 5 to CLASS 30), minimize project completion times, inventories and power consumption, and optimize plant availability and maintenance management.

Application

The 3RB22/3RB23 solid-state overload relays have been designed for the protection of three-phase asynchronous and single-phase AC motors.

If single-phase AC motors are to be protected by the 3RB22/3RB23 solid-state overload relays, the main circuits of the current measuring modules must be series-connected (see [LV 1 T, Schematics](#)).

Ambient conditions

The devices are insensitive to external influences such as shocks, corrosive environments, ageing and temperature changes.

For the temperature range from -25 °C to $+60\text{ °C}$, the 3RB22/3RB23 solid-state overload relays compensate the temperature according to IEC 60947-4-1.

Configuration notes for use of the devices below -25 °C or above $+60\text{ °C}$ on request.

"Increased safety" type of protection EEx e according to ATEX guideline 94/9/EC

The 3RB22/3RB23 solid-state overload relays are suitable for the overload protection of explosion-proof motors with "increased safety" type of protection EEx e. The relays meet the requirements of EN 60079-7 (Electrical apparatus for potentially explosive atmospheres – Increased safety "e").

When using 3RB23 solid-state overload relays for the protection of EEx e motors, separate monitoring of the control supply voltage is recommended.

The basic safety and health requirements of ATEX guideline 94/9/EG are fulfilled by compliance with

- EN 60947-1
- EN 60947-4-1
- EN 60947-5-1
- EN 60079-14

EU type test certificate for Group II, Category (2) G/D under application. Number on request.

Accessories

The following accessories are available for the 3RB22/3RB23 solid-state overload relays:

- A sealable cover for the evaluation module
- Box terminal blocks for the current measuring modules size S6 and S10/S12
- Terminal covers for the current measuring modules size S6 and S10/S12
- Push-in lugs for screw mounting the size S00 to S3 current measuring modules

Overload Relays

3RB2 Solid-State Overload Relays

3RB22, 3RB23 for high-feature applications

Selection and ordering data

Conversion aid 3RB12 → 3RB22/3RB23

| Size | Old Order No. Complete unit | Setting range A | New Order No. Current measuring module | Setting range A | New Order No. Evaluation module | New Order No. Function expansion module |
|--|--------------------------------|--------------------|--|--------------------|------------------------------------|---|
| S00/S0 | 3RB12 46-1P □□□ | 1.25 ... 6.3 | 3RB29 06-2BG1 | 0.3 ... 3 | | |
| | 3RB12 46-1Q □□□ | 6.3 ... 25 | 3RB29 06-2DG1 | 2.4 ... 25 | | |
| S2/S3 | 3RB12 46-1E □□□ | 25 ... 100 | 3RB29 06-2JG1 | 10 ... 100 | 3RB29 83-4AA1 | 3RB29 85-2 □□□ |
| S6 | 3RB12 53-1F □□□ | 50 ... 205 | 3RB29 56-2TG2 | 20 ... 200 | | |
| | | | 3RB29 56-2TH2 | | | |
| S10/S12 | 3RB12 57-0K □□□ | 125 ... 500 | 3RB29 66-2WH2 | 63 ... 630 (820) | | |
| | 3RB12 62-0L □□□ | 200 ... 820 | | | | |
| 110 ... 120 V AC | G | | | | Integrated | Integrated |
| 220 ... 240 V AC | M | | | | Integrated | Integrated |
| 24 V DC | B | | | | Integrated | Integrated |
| Standard design with ground fault signal | 00 | | | | Not available | -- |
| Standard design with overload warning | 10 | | | | 2 | Not required |
| Version with internal ground fault detection and ground fault signal | 20 | | | | 2 | CB1 |
| Version with internal ground fault detection and overload warning | 30 | | | | 2 | CA1 |
| Version with analog output | 40 | | | | 2 | AA0 |
| Bistable version with ground fault signal | 01 | | | | Not available | -- |
| Bistable version with overload warning | 11 | | | | 3 | Not required |

Overload Relays



3RB2 Solid-State Overload Relays

3RB22, 3RB23 for high-feature applications

3RB22/3RB23 solid-state overload relays for full motor protection with screw connection or spring-loaded terminals for stand-alone installation, CLASS 5, 10, 20 and 30 adjustable

Features and technical specifications:

- Overload protection, phase failure protection and unbalance protection
- External power supply 24 ... 240 V AC/DC
- Auxiliary contacts 2 NO +2 NC
- Manual and automatic RESET
- Electrical remote RESET integrated
- 4 LEDs for operating and status displays
- TEST function and self-monitoring
- Internal ground fault detection with function expansion module
- Screw connection or spring-loaded terminals for auxiliary, control and sensor circuits
- Input for PTC sensor circuit
- Analog output with function expansion module

| Size Contactor | Version | Connection type | DT | Order No. | Price per PU | PU (UNIT, SET, M) | PS* | PG | Weight per PU approx. kg |
|--|--|-------------------------|----------------------|----------------------|--------------|-------------------|--------|-------|--------------------------|
| Evaluation modules | | | | | | | | | |
|  | S00 ... S12 Monostable | Screw connection | ▶ | 3RB22 83-4AA1 | | 1 | 1 unit | 101 | 0.300 |
| | | Spring-loaded terminals | A | 3RB22 83-4AC1 | | 1 | 1 unit | 101 | 0.300 |
| | Bistable | Screw connection | ▶ | 3RB23 83-4AA1 | | 1 | 1 unit | 101 | 0.300 |
| | | Spring-loaded terminals | A | 3RB23 83-4AC1 | | 1 | 1 unit | 101 | 0.300 |
|  | | | | | | | | | |
| Function expansion modules | | | | | | | | | |
| – | Analog Basic 1 module ¹⁾ Analog output DC 4 ... 20 mA, with overload warning | ▶ | 3RB29 85-2AA0 | | 1 | 1 unit | 101 | 0.030 | |
| | Analog Basic 1 GF module ¹⁾²⁾ Analog output DC 4 ... 20 mA, with internal ground fault detection and overload warning | ▶ | 3RB29 85-2AA1 | | 1 | 1 unit | 101 | 0.030 | |
| | Analog Basic 2 GF module ¹⁾²⁾ Analog output DC 4 ... 20 mA, with internal ground fault detection and ground fault signaling | ▶ | 3RB29 85-2AB1 | | 1 | 1 unit | 101 | 0.030 | |
| | Basic 1 GF module ²⁾ with internal ground fault detection and overload warning | ▶ | 3RB29 85-2CA1 | | 1 | 1 unit | 101 | 0.030 | |
| | Basic 2 GF module ²⁾ with internal ground fault detection and ground fault signaling | ▶ | 3RB29 85-2CB1 | | 1 | 1 unit | 101 | 0.030 | |

1) The analog signal 4 ... 20 mA DC can be used for operating rotary coil instruments or for feeding into analog inputs of programmable logic controllers.

2) The following information on ground fault protection refers to sinusoidal residual currents at 50/60 Hz:





- With a motor current of between 0.3 and 2 times the set current I_e the unit will trip at a ground fault current equal to 30% of the set current.
- With a motor current of between 2 and 8 times the set current I_e the unit will trip at a ground fault current equal to 15% of the set current.
- The trip delay amounts to between 0.5 and 1 second.

Overload Relays

3RB2 Solid-State Overload Relays

3RB22, 3RB23 for high-feature applications

Current measuring modules for direct mounting¹⁾ and stand-alone installation¹⁾²⁾

| Size Contactor ³⁾ | Rating for induction motor, Rated value ⁴⁾ | Set current value of the inverse-time delayed overload trip | Short-circuit protection with fuse, type of coordination 2, gL/gG operational class ⁵⁾ | DT | Order No. | Price per PU | PU (UNIT, SET, M) | PS* | PG | Weight per PU approx. |
|---|---|---|---|-----|------------------------|--------------|-------------------|--------|-----|-----------------------|
| | kW | A | A | | | | | | | kg |
| Size S00/S0²⁾⁶⁾ | | | | | | | | | | |
|  | S00/S0 | 0.09 ... 1.1 | 0.3 ... 3 | 16 | ▶ 3RB29 06-2BG1 | | 1 | 1 unit | 101 | 0.100 |
| | | 1.1 ... 11 | 2.4 ... 25 | 63 | ▶ 3RB29 06-2DG1 | | 1 | 1 unit | 101 | 0.150 |
| Size S2/S3²⁾⁶⁾ | | | | | | | | | | |
|  | S2/S3 | 5.5 ... 45 | 10 ... 100 | 250 | ▶ 3RB29 06-2JG1 | | 1 | 1 unit | 101 | 0.350 |
| Size S6¹⁾⁶⁾ | | | | | | | | | | |
|  | S6 | 11 ... 90 | 20 ... 200 | 355 | ▶ 3RB29 56-2TG2 | | 1 | 1 unit | 101 | 0.600 |
| | | | | | ▶ 3RB29 56-2TH2 | | 1 | 1 unit | 101 | 1.000 |
| Size S10/S12¹⁾ | | | | | | | | | | |
|  | S10/S12 and size 14 (3TF68/3TF69) | 37 ... 450 | 63 ... 630 | 630 | ▶ 3RB29 66-2WH2 | | 1 | 1 unit | 101 | 1.750 |

- 1) The current measuring modules with an Order No. ending with "2" are designed for direct mounting and stand-alone installation. For 3TF68/3TF69 contactors, direct mounting is not possible.
- 2) The current measuring modules with an Order No. ending with "1" are designed for stand-alone installation.
- 3) Observe maximum rated operational current of the devices.

- 4) Standard value for 4-pole standard motors at 50 Hz 400 V AC. The actual starting and rated data of the motor to be protected must be considered when selecting the units.
- 5) Maximum fuse for overload relay, type of coordination 2. For fuse values in conjunction with contactors, see Technical Specifications, Short-Circuit Protection with Fuses for Motor Feeders.
- 6) The modules with an Order No. with "G" in penultimate position are equipped with a straight-through transformer.

| Size Contactor | Version | DT | Order No. | Price per PU | PU (UNIT, SET, M) | PS* | PG | Weight per PU approx. |
|---|-------------|---|----------------------|--------------|-------------------|--------|-----|-----------------------|
| | | | | | | | | kg |
| Connecting leads | | | | | | | | |
|  | S00 ... S12 | For connection between evaluation module and current measuring module | | | | | | |
| | | • Length 0.1 m • Length 0.5 m | ▶ 3RB29 87-2B | | 1 | 1 unit | 101 | 0.010 |
| | | | ▶ 3RB29 87-2D | | 1 | 1 unit | 101 | 0.020 |

3RB29 87-2.

Overview

Overload relays for standard applications

The following accessories are available for the 3RB20/3RB21 solid-state overload relays:



- One terminal bracket each for the overload relays size S00 and S0 (sizes S2 to S12 can be installed as single units without a terminal bracket)
- One mechanical RESET module for all sizes
- One cable release for resetting devices which are difficult to access (for all sizes)
- One sealable cover for all sizes
- Box terminal blocks for sizes S6 and S10/S12
- Terminal covers for sizes S2 to S10/S12

Overload relays for high-feature applications

The following accessories are available for the 3RB22/3RB23 solid-state overload relays:

- A sealable cover for the evaluation module
- Box terminal blocks for the current measuring modules size S6 and S10/S12
- Terminal covers for the current measuring modules size S6 and S10/S12
- Push-in lugs for screw mounting the size S00 to S3 current measuring modules

Selection and ordering data

| Version | Size | DT | Order No. | Price per PU | PU (UNIT, SET, M) | PS* | PG | Weight per PU approx. kg |
|---|---|-----------------|-----------|-----------------------|-------------------|--------|-----|--------------------------|
| Terminal brackets for stand-alone installation¹⁾ | | | | | | | | |
|  | For separate mounting of the overload relays; screw and snap-on mounting onto TH35 standard mounting rail | S00 | A | 3RB29 13-0AA1 | 1 | 1 unit | 101 | 0.060 |
| | | S0 | A | 3RB29 23-0AA1 | 1 | 1 unit | 101 | 0.080 |
| Mechanical RESET²⁾ | | | | | | | | |
|  | Resetting plungers, holders and formers | S00 ... S10/S12 | ▶ | 3RU19 00-1A | 1 | 1 set | 101 | 0.038 |
| | Pushbuttons with extended stroke (12 mm), IP65, Ø 22 mm | | B | 3SB30 00-0EA11 | 1 | 1 unit | 102 | 0.021 |
| | Extension plungers For compensation of the distance between a pushbutton and the unlatching button of the relay | | A | 3SX1 335 | 1 | 1 unit | 102 | 0.004 |
| Cable releases with holder for RESET²⁾ | | | | | | | | |
|  | For holes with Ø 6.5 mm in the mounting plate; max. control panel thickness 8 mm | S00 ... S10/S12 | ▶ | 3RU19 00-1B | 1 | 1 unit | 101 | 0.063 |
| | • Length 400 mm • Length 600 mm | | ▶ | 3RU19 00-1C | 1 | 1 unit | 101 | 0.073 |

3RB29 .3-0AA1

3RU19 00-1A
with pushbutton and
extension plunger

3RU19 00-1.





1) Only for 3RB20/3RB21.

2) Only for 3RB20/3RB21. The accessories are identical to those of the 3RU11 thermal overload relays.

Overload Relays

3RB2 Solid-State Overload Relays

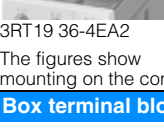
Accessories

| Version | Size | DT | Order No. | Price per PU | PU (UNIT, SET, M) | PS* | PG | Weight per PU approx. kg |
|---|---|------------------|------------------------|--------------|-------------------|----------|-----|--------------------------|
| Sealable covers | | | | | | | | |
| For covering the setting knobs | | | | | | | | |
| | • For 3RB20/3RB21 | S00 ... S10/S12 | ▶ 3RB29 84-0 | | 1 | 10 units | 101 | 0.020 |
| | • For 3RB22/3RB23 | – | ▶ 3RB29 84-2 | | 1 | 10 units | 101 | 0.050 |
| Terminal covers | | | | | | | | |
| Covers for cable lugs and rail connection | | | | | | | | |
|  | • Length 55 mm ¹⁾ | S3 | ▶ 3RT19 46-4EA1 | | 1 | 1 unit | 101 | 0.037 |
| | • Length 100 mm | S6 | ▶ 3RT19 56-4EA1 | | 1 | 1 unit | 101 | 0.067 |
| | • Length 120 mm | S10/S12 | ▶ 3RT19 66-4EA1 | | 1 | 1 unit | 101 | 0.124 |
| Covers for box terminals | | | | | | | | |
|  | • Length 20.6 mm ¹⁾ | S2 | ▶ 3RT19 36-4EA2 | | 1 | 1 unit | 101 | 0.016 |
| | • Length 20.8 mm ¹⁾ | S3 | ▶ 3RT19 46-4EA2 | | 1 | 1 unit | 101 | 0.023 |
| | • Length 25 mm | S6 | ▶ 3RT19 56-4EA2 | | 1 | 1 unit | 101 | 0.028 |
| | • Length 30 mm | S10/S12 | ▶ 3RT19 66-4EA2 | | 1 | 1 unit | 101 | 0.038 |
| Covers for screw connections | | | | | | | | |
|  | between contactor and overload relay, without box terminals | S6 | ▶ 3RT19 56-4EA3 | | 1 | 1 unit | 101 | 0.021 |
| | (1 unit required per combination) | S10/S12 | ▶ 3RT19 66-4EA3 | | 1 | 1 unit | 101 | 0.062 |
| Box terminal blocks | | | | | | | | |
|  | For round and ribbon cables up to 70 mm ² | S6 ²⁾ | ▶ 3RT19 55-4G | | 1 | 1 unit | 101 | 0.237 |
| | up to 120mm ² | S6 | ▶ 3RT19 56-4G | | 1 | 1 unit | 101 | 0.270 |
| | up to 240mm ² | S10/S12 | ▶ 3RT19 66-4G | | 1 | 1 unit | 101 | 0.676 |
| For conductor cross-sections, see LV 1 T "Technical Specifications" | | | | | | | | |
| Push-in lugs | | | | | | | | |
|  | For screw mounting of 3RB29 06 current measuring modules | S00 ... S3 | ▶ 3RB19 00-0B | | 100 | 10 units | 101 | 0.100 |
| (2 units are required per module) | | | | | | | | |

For more accessories (tools for spring-loaded terminals and labeling plates), see page 5/56.

1) Only for 3RB20/3RB21. The accessories are identical to those of the 3RU11 thermal overload relays.

2) In the scope of supply for 3RT10 54-1 contactors (55 kW).

Overview

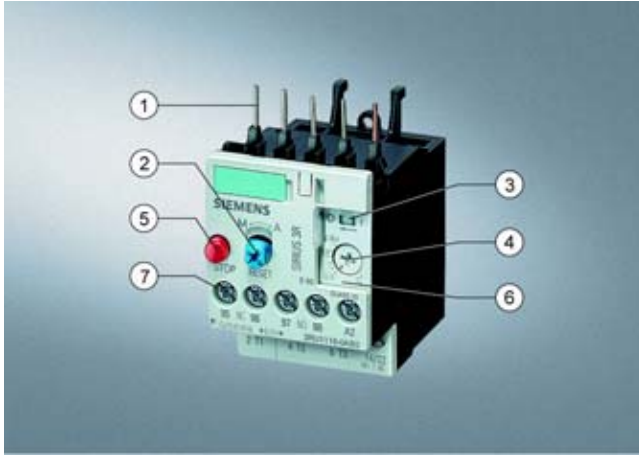

- (1) Connection for mounting onto contactors:
Optimally adapted in electrical, mechanical and design terms to the contactors, these connecting pins can be used for direct mounting of the overload relays. Stand-alone installation is possible as an alternative (in some cases in conjunction with a stand-alone installation module).
- (2) Selector switch for manual/automatic RESET and RESET button:
With this switch you can choose between manual and automatic RESET. A device set to manual RESET can be reset locally by pressing the RESET button. A remote RESET is possible using the RESET modules (accessories), which are independent of size.
- (3) Switch position indicator and TEST function of the wiring:
Indicates a trip and enables the wiring test.
- (4) Motor current setting:
Setting the device to the rated motor current is easy with the large rotary knob.
- (5) STOP button:
If the STOP button is pressed, the NC contact is opened. This switches off the contactor downstream. The contactor is switched on again when the STOP button is released.
- (6) Transparent, sealable cover:
Secures the motor current setting, TEST function and the selector switch for manual/automatic RESET against adjustment.
- (7) Supply terminals:
The generously sized terminals permit connection of two conductors with different cross-sections for the main and auxiliary circuits. The auxiliary circuit can be connected with screw-type terminals and alternatively with spring-loaded terminals.

The 3RU11 thermal overload relays up to 100 A have been designed for current-dependent protection of loads with normal starting (see LV 1 T, Function) against excessive temperature rises due to overload or phase failure. An overload or phase failure results in an increase of the motor current beyond the set motor rated current. Via heating elements, this current rise heats up the bimetal strips inside the device, which then bend and as a result trigger the auxiliary contacts by means of a tripping mechanism. The auxiliary contacts then switch off the load by means of a contactor. The break time depends on the ratio between the tripping current and set current I_{θ} and is stored in the form of a long-term stable tripping characteristic (see LV 1 T, Characteristic Curves).

The "tripped" status is signaled by means of a switch position indicator (see LV 1 T, Function). Resetting takes place either manually or automatically after the recovery time has elapsed (see LV 1 T, Function).

The devices are manufactured in accordance with environmental guidelines and contain environmentally friendly and reusable materials.

They comply with all important worldwide standards and approvals.

Benefits

The most important features and benefits of the 3RU11 thermal overload relays are listed in the overview table (see Overload Relays, General Data).

Application

Industries

The 3RU11 thermal overload relays are suitable for customers from all industries who want to guarantee optimum inverse-time delayed protection of their electrical loads (e.g. motors) under normal starting conditions (CLASS 10).

Application

The 3RU11 thermal overload relays have been designed for the protection of three-phase and single-phase AC and DC motors.

If single-phase AC or DC loads are to be protected by the 3RU11 thermal overload relays, all three bimetal strips must be heated. For this purpose, all main circuits of the relay must be connected in series.

Ambient conditions

The 3RU11 thermal overload relays have temperature compensation in accordance with IEC 60947-4-1 for the temperature range of -20 to $+60$ °C. For temperatures from $+60$ to $+80$ °C the upper setpoint value of the setting range must be reduced by the factor listed in the table below.

| Ambient temperature in °C | Derating factor for the upper setpoint value |
|---------------------------|--|
| +60 | 1.0 |
| +65 | 0.94 |
| +70 | 0.87 |
| +75 | 0.81 |
| +80 | 0.73 |

"Increased safety" type of protection EEx e according to ATEX guideline 94/9/EC

The 3RU11 thermal overload relays are suitable for the overload protection of explosion-proof motors with "increased safety" type of protection EEx e. The relays meet the requirements of EN 60079-7 (Electrical apparatus for potentially explosive atmospheres – Increased safety "e").

The basic safety and health requirements of ATEX guideline 94/9/EG are fulfilled by compliance with

- EN 60947-4-1
- EN 60947-5-1
- EN 60079-14: 1997-02
- EN 60079-17: 1996-12

EU type test certificate for Category (2) G/D exists. It has the number DMT 98 ATEX 6001.

Overload Relays

3RU1 Thermal Overload Relays

3RU11 for standard applications





Selection and ordering data

3RU11 thermal overload relays with screw connection on the auxiliary current side for direct mounting¹⁾, CLASS 10

Features and technical specifications:

- Overload and phase failure protection
- Auxiliary contacts 1 NO + 1 NC
- Manual and automatic RESET

- Switch position indicator
- TEST function
- STOP button
- Integrated, sealable cover

| Size | Con-tactor ²⁾ | Rating for induction motor, Rated value ³⁾ | Set current value of the inverse-time delayed overload trip | Short-circuit protection with fuse, type of coordination 2, gL/gG operational class ⁴⁾ | DT | Order No. | Price per PU | PU (UNIT, SET, M) | PS* | PG | Weight per PU approx. |
|---|--------------------------|---|---|---|----|----------------------|--------------|-------------------|--------|-----|-----------------------|
| | | kW | A | A | | | | | | | kg |
| Size S00 | | | | | | | | | | | |
|  | S00 | 0.04 | 0.11 ... 0.16 | 0.5 | A | 3RU11 16-0AB0 | | 1 | 1 unit | 101 | 0.150 |
| | | 0.06 | 0.14 ... 0.2 | 1 | A | 3RU11 16-0BB0 | | 1 | 1 unit | 101 | 0.150 |
| | | 0.06 | 0.18 ... 0.25 | 1 | ▶ | 3RU11 16-0CB0 | | 1 | 1 unit | 101 | 0.150 |
| | | 0.09 | 0.22 ... 0.32 | 1.6 | ▶ | 3RU11 16-0DB0 | | 1 | 1 unit | 101 | 0.150 |
| | | 0.09 | 0.28 ... 0.4 | 2 | ▶ | 3RU11 16-0EB0 | | 1 | 1 unit | 101 | 0.150 |
| | | 0.12 | 0.35 ... 0.5 | 2 | ▶ | 3RU11 16-0FB0 | | 1 | 1 unit | 101 | 0.150 |
| | | 0.18 | 0.45 ... 0.63 | 2 | ▶ | 3RU11 16-0GB0 | | 1 | 1 unit | 101 | 0.150 |
| | | 0.18 | 0.55 ... 0.8 | 4 | ▶ | 3RU11 16-0HB0 | | 1 | 1 unit | 101 | 0.150 |
| | | 0.25 | 0.7 ... 1 | 4 | ▶ | 3RU11 16-0JB0 | | 1 | 1 unit | 101 | 0.150 |
| | | 0.37 | 0.9 ... 1.25 | 4 | ▶ | 3RU11 16-0KB0 | | 1 | 1 unit | 101 | 0.150 |
| | | 0.55 | 1.1 ... 1.6 | 6 | ▶ | 3RU11 16-1AB0 | | 1 | 1 unit | 101 | 0.150 |
| | | 0.75 | 1.4 ... 2 | 6 | ▶ | 3RU11 16-1BB0 | | 1 | 1 unit | 101 | 0.150 |
| | | 0.75 | 1.8 ... 2.5 | 10 | ▶ | 3RU11 16-1CB0 | | 1 | 1 unit | 101 | 0.150 |
| | | 1.1 | 2.2 ... 3.2 | 10 | ▶ | 3RU11 16-1DB0 | | 1 | 1 unit | 101 | 0.150 |
| | | 1.5 | 2.8 ... 4 | 16 | ▶ | 3RU11 16-1EB0 | | 1 | 1 unit | 101 | 0.150 |
| 1.5 | 3.5 ... 5 | 20 | ▶ | 3RU11 16-1FB0 | | 1 | 1 unit | 101 | 0.150 | | |
| 2.2 | 4.5 ... 6.3 | 20 | ▶ | 3RU11 16-1GB0 | | 1 | 1 unit | 101 | 0.150 | | |
| 3 | 5.5 ... 8 | 25 | ▶ | 3RU11 16-1HB0 | | 1 | 1 unit | 101 | 0.150 | | |
| 4 | 7 ... 10 | 35 | ▶ | 3RU11 16-1JB0 | | 1 | 1 unit | 101 | 0.150 | | |
| 5.5 | 9 ... 12 | 35 | ▶ | 3RU11 16-1KB0 | | 1 | 1 unit | 101 | 0.150 | | |
| Size S0 | | | | | | | | | | | |
|  | S0 | 0.75 | 1.8 ... 2.5 | 10 | ▶ | 3RU11 26-1CB0 | | 1 | 1 unit | 101 | 0.190 |
| | | 1.1 | 2.2 ... 3.2 | 10 | ▶ | 3RU11 26-1DB0 | | 1 | 1 unit | 101 | 0.190 |
| | | 1.5 | 2.8 ... 4 | 16 | ▶ | 3RU11 26-1EB0 | | 1 | 1 unit | 101 | 0.190 |
| | | 1.5 | 3.5 ... 5 | 20 | ▶ | 3RU11 26-1FB0 | | 1 | 1 unit | 101 | 0.190 |
| | | 2.2 | 4.5 ... 6.3 | 20 | ▶ | 3RU11 26-1GB0 | | 1 | 1 unit | 101 | 0.190 |
| | | 3 | 5.5 ... 8 | 25 | ▶ | 3RU11 26-1HB0 | | 1 | 1 unit | 101 | 0.190 |
| | | 4 | 7 ... 10 | 35 | ▶ | 3RU11 26-1JB0 | | 1 | 1 unit | 101 | 0.190 |
| | | 5.5 | 9 ... 12.5 | 35 | ▶ | 3RU11 26-1KB0 | | 1 | 1 unit | 101 | 0.190 |
| | | 7.5 | 11 ... 16 | 40 | ▶ | 3RU11 26-4AB0 | | 1 | 1 unit | 101 | 0.190 |
| | | 7.5 | 14 ... 20 | 50 | ▶ | 3RU11 26-4BB0 | | 1 | 1 unit | 101 | 0.190 |
| | | 11 | 17 ... 22 | 63 | ▶ | 3RU11 26-4CB0 | | 1 | 1 unit | 101 | 0.190 |
| | | 11 | 20 ... 25 | 63 | ▶ | 3RU11 26-4DB0 | | 1 | 1 unit | 101 | 0.190 |
| Size S2 | | | | | | | | | | | |
|  | S2 | 3 | 5.5 ... 8 | 25 | A | 3RU11 36-1HB0 | | 1 | 1 unit | 101 | 0.320 |
| | | 4 | 7 ... 10 | 35 | A | 3RU11 36-1JB0 | | 1 | 1 unit | 101 | 0.320 |
| | | 5.5 | 9 ... 12.5 | 35 | A | 3RU11 36-1KB0 | | 1 | 1 unit | 101 | 0.320 |
| | | 7.5 | 11 ... 16 | 40 | ▶ | 3RU11 36-4AB0 | | 1 | 1 unit | 101 | 0.320 |
| | | 7.5 | 14 ... 20 | 50 | ▶ | 3RU11 36-4BB0 | | 1 | 1 unit | 101 | 0.320 |
| | | 11 | 18 ... 25 | 63 | ▶ | 3RU11 36-4DB0 | | 1 | 1 unit | 101 | 0.320 |
| | | 15 | 22 ... 32 | 80 | ▶ | 3RU11 36-4EB0 | | 1 | 1 unit | 101 | 0.320 |
| | | 18.5 | 28 ... 40 | 80 | ▶ | 3RU11 36-4FB0 | | 1 | 1 unit | 101 | 0.320 |
| | | 22 | 36 ... 45 | 100 | ▶ | 3RU11 36-4GB0 | | 1 | 1 unit | 101 | 0.320 |
| 22 | 40 ... 50 | 100 | ▶ | 3RU11 36-4HB0 | | 1 | 1 unit | 101 | 0.320 | | |
| Size S3 | | | | | | | | | | | |
|  | S3 | 11 | 18 ... 25 | 63 | A | 3RU11 46-4DB0 | | 1 | 1 unit | 101 | 0.550 |
| | | 15 | 22 ... 32 | 80 | A | 3RU11 46-4EB0 | | 1 | 1 unit | 101 | 0.550 |
| | | 18.5 | 28 ... 40 | 80 | ▶ | 3RU11 46-4FB0 | | 1 | 1 unit | 101 | 0.550 |
| | | 22 | 36 ... 50 | 125 | ▶ | 3RU11 46-4HB0 | | 1 | 1 unit | 101 | 0.550 |
| | | 30 | 45 ... 63 | 125 | ▶ | 3RU11 46-4JB0 | | 1 | 1 unit | 101 | 0.550 |
| | | 37 | 57 ... 75 | 160 | ▶ | 3RU11 46-4KB0 | | 1 | 1 unit | 101 | 0.550 |
| | | 45 | 70 ... 90 | 160 | ▶ | 3RU11 46-4LB0 | | 1 | 1 unit | 101 | 0.550 |
| | | 45 | 80 ... 100 ⁵⁾ | 200 | ▶ | 3RU11 46-4MB0 | | 1 | 1 unit | 101 | 0.550 |

1) With the suitable terminal brackets (see Accessories) the 3RU11 overload relays for direct mounting can also be installed as stand-alone units.

2) Observe maximum rated operational current of the devices.

3) Standard value for 4-pole standard motors at 50 Hz 400 V AC. The actual starting and rated data of the motor to be protected must be considered when selecting the units.

4) Maximum fuse for overload relay, type of coordination 2. For fuse values in conjunction with contactors, see Technical Specifications, Short-Circuit Protection with Fuses/Motor Starter Protectors for Motor Feeders.

5) For overload relays > 100 A, see 3RB2.

Overload Relays

3RU1 Thermal Overload Relays

3RU11 for standard applications

3RU11 thermal overload relays with screw connection on the auxiliary current side for stand alone installation¹⁾, CLASS 10

Features and technical specifications:

- Overload and phase failure protection
- Auxiliary contacts 1 NO + 1 NC
- Manual and automatic RESET

- Switch position indicator
- TEST function
- STOP button
- Integrated, sealable cover

| Size Con-tactor ²⁾ | Rating for induction motor, Rated value ³⁾ | Set current value of the inverse-time delayed overload trip | Short-circuit protection with fuse, type of coordination 2, gL/gG operational class ⁴⁾ | DT | Order No. | Price per PU | PU (UNIT, SET, M) | PS* | PG | Weight per PU approx. |
|-------------------------------|---|---|---|----|----------------------|--------------|-------------------|--------|-----|-----------------------|
| | kW | A | A | | | | | | | kg |
| Size S00 | | | | | | | | | | |
| S00 | 0.04 | 0.11 ... 0.16 | 0.5 | B | 3RU11 16-0AB1 | | 1 | 1 unit | 101 | 0.180 |
| | 0.06 | 0.14 ... 0.2 | 1 | B | 3RU11 16-0BB1 | | 1 | 1 unit | 101 | 0.180 |
| | 0.06 | 0.18 ... 0.25 | 1 | B | 3RU11 16-0CB1 | | 1 | 1 unit | 101 | 0.180 |
| | 0.09 | 0.22 ... 0.32 | 1.6 | B | 3RU11 16-0DB1 | | 1 | 1 unit | 101 | 0.180 |
| | 0.09 | 0.28 ... 0.4 | 2 | A | 3RU11 16-0EB1 | | 1 | 1 unit | 101 | 0.180 |
| | 0.12 | 0.35 ... 0.5 | 2 | A | 3RU11 16-0FB1 | | 1 | 1 unit | 101 | 0.180 |
| | 0.18 | 0.45 ... 0.63 | 2 | A | 3RU11 16-0GB1 | | 1 | 1 unit | 101 | 0.180 |
| | 0.18 | 0.55 ... 0.8 | 4 | A | 3RU11 16-0HB1 | | 1 | 1 unit | 101 | 0.180 |
| | 0.25 | 0.7 ... 1 | 4 | ▶ | 3RU11 16-0JB1 | | 1 | 1 unit | 101 | 0.180 |
| | 0.37 | 0.9 ... 1.25 | 4 | A | 3RU11 16-0KB1 | | 1 | 1 unit | 101 | 0.180 |
| | 0.55 | 1.1 ... 1.6 | 6 | ▶ | 3RU11 16-1AB1 | | 1 | 1 unit | 101 | 0.180 |
| | 0.75 | 1.4 ... 2 | 6 | ▶ | 3RU11 16-1BB1 | | 1 | 1 unit | 101 | 0.180 |
| | 0.75 | 1.8 ... 2.5 | 10 | ▶ | 3RU11 16-1CB1 | | 1 | 1 unit | 101 | 0.180 |
| | 1.1 | 2.2 ... 3.2 | 10 | ▶ | 3RU11 16-1DB1 | | 1 | 1 unit | 101 | 0.180 |
| | 1.5 | 2.8 ... 4 | 16 | ▶ | 3RU11 16-1EB1 | | 1 | 1 unit | 101 | 0.180 |
| | 1.5 | 3.5 ... 5 | 20 | ▶ | 3RU11 16-1FB1 | | 1 | 1 unit | 101 | 0.180 |
| | 2.2 | 4.5 ... 6.3 | 20 | ▶ | 3RU11 16-1GB1 | | 1 | 1 unit | 101 | 0.180 |
| | 3 | 5.5 ... 8 | 25 | ▶ | 3RU11 16-1HB1 | | 1 | 1 unit | 101 | 0.180 |
| | 4 | 7 ... 10 | 35 | ▶ | 3RU11 16-1JB1 | | 1 | 1 unit | 101 | 0.180 |
| | 5.5 | 9 ... 12 | 35 | A | 3RU11 16-1KB1 | | 1 | 1 unit | 101 | 0.180 |
| Size S0 | | | | | | | | | | |
| S0 | 7.5 | 11 ... 16 | 40 | ▶ | 3RU11 26-4AB1 | | 1 | 1 unit | 101 | 0.240 |
| | 7.5 | 14 ... 20 | 50 | ▶ | 3RU11 26-4BB1 | | 1 | 1 unit | 101 | 0.240 |
| | 11 | 17 ... 22 | 63 | A | 3RU11 26-4CB1 | | 1 | 1 unit | 101 | 0.240 |
| | 11 | 20 ... 25 | 63 | ▶ | 3RU11 26-4DB1 | | 1 | 1 unit | 101 | 0.240 |
| Size S2 | | | | | | | | | | |
| S2 | 15 | 22 ... 32 | 80 | ▶ | 3RU11 36-4EB1 | | 1 | 1 unit | 101 | 0.480 |
| | 18.5 | 28 ... 40 | 80 | ▶ | 3RU11 36-4FB1 | | 1 | 1 unit | 101 | 0.480 |
| | 22 | 36 ... 45 | 100 | A | 3RU11 36-4GB1 | | 1 | 1 unit | 101 | 0.480 |
| | 22 | 40 ... 50 | 100 | A | 3RU11 36-4HB1 | | 1 | 1 unit | 101 | 0.480 |
| Size S3 | | | | | | | | | | |
| S3 | 30 | 45 ... 63 | 125 | ▶ | 3RU11 46-4JB1 | | 1 | 1 unit | 101 | 0.810 |
| | 37 | 57 ... 75 | 160 | A | 3RU11 46-4KB1 | | 1 | 1 unit | 101 | 0.810 |
| | 45 | 70 ... 90 | 160 | A | 3RU11 46-4LB1 | | 1 | 1 unit | 101 | 0.810 |
| | 45 | 80 ... 100 ⁵⁾ | 200 | A | 3RU11 46-4MB1 | | 1 | 1 unit | 101 | 0.810 |

1) Size S00 to S3 for screw and snap-on mounting onto TH 35 standard mounting rails, size S3 also for TH 75 standard mounting rails.

2) Observe maximum rated operational current of the devices.

3) Standard value for 4-pole standard motors at 50 Hz 400 V AC. The actual starting and rated data of the motor to be protected must be considered when selecting the units.

4) Maximum fuse for overload relay, type of coordination 2. For fuse values in conjunction with contactors, see Technical Specifications, Short-Circuit Protection with Fuses/Motor Starter Protectors for Motor Feeders.

5) For overload relays > 100 A, see 3RB2.

Overload Relays

3RU1 Thermal Overload Relays





3RU11 for standard applications

3RU11 thermal overload relays with Cage Clamp connection for direct mounting¹⁾ and stand-alone installation²⁾, CLASS 10

Features and technical specifications:

- Overload and phase failure protection
- Auxiliary contacts 1 NO + 1 NC
- Manual and automatic RESET

- Switch position indicator
- TEST function
- STOP button
- Integrated, sealable cover

| Size Con-tactor ³⁾ | Rating for induction motor Rated value ⁴⁾ | Set current value of the inverse-time delayed overload trip | Short-circuit protection with fuse, type of coordination 2, gL/gG operational class ⁵⁾ | DT | Order No. | Price per PU | PU (UNIT, SET, M) | PS* | PG | Weight per PU approx. |
|---|--|---|---|-----|----------------------|----------------------|-------------------|--------|-------|-----------------------|
| | kW | A | A | | | | | | | kg |
| Size S00 for stand-alone installation⁶⁾ | | | | | | | | | | |
|  3RU11 16-...C1 | S00 | 0.04 | 0.11 ... 0.16 | 0.5 | B | 3RU11 16-0AC1 | 1 | 1 unit | 101 | 0.190 |
| | | 0.06 | 0.14 ... 0.2 | 1 | B | 3RU11 16-0BC1 | 1 | 1 unit | 101 | 0.190 |
| | | 0.06 | 0.18 ... 0.25 | 1 | B | 3RU11 16-0CC1 | 1 | 1 unit | 101 | 0.190 |
| | | 0.09 | 0.22 ... 0.32 | 1.6 | B | 3RU11 16-0DC1 | 1 | 1 unit | 101 | 0.190 |
| | | 0.09 | 0.28 ... 0.4 | 2 | B | 3RU11 16-0EC1 | 1 | 1 unit | 101 | 0.190 |
| | | 0.12 | 0.35 ... 0.5 | 2 | B | 3RU11 16-0FC1 | 1 | 1 unit | 101 | 0.190 |
| | | 0.18 | 0.45 ... 0.63 | 2 | A | 3RU11 16-0GC1 | 1 | 1 unit | 101 | 0.190 |
| | | 0.18 | 0.55 ... 0.8 | 4 | A | 3RU11 16-0HC1 | 1 | 1 unit | 101 | 0.190 |
| | | 0.25 | 0.7 ... 1 | 4 | A | 3RU11 16-0JC1 | 1 | 1 unit | 101 | 0.190 |
| | | 0.37 | 0.9 ... 1.25 | 4 | A | 3RU11 16-0KC1 | 1 | 1 unit | 101 | 0.190 |
| | | 0.55 | 1.1 ... 1.6 | 6 | A | 3RU11 16-1AC1 | 1 | 1 unit | 101 | 0.190 |
| | | 0.75 | 1.4 ... 2 | 6 | A | 3RU11 16-1BC1 | 1 | 1 unit | 101 | 0.190 |
| | | 0.75 | 1.8 ... 2.5 | 10 | A | 3RU11 16-1CC1 | 1 | 1 unit | 101 | 0.190 |
| | | 1.1 | 2.2 ... 3.2 | 10 | A | 3RU11 16-1DC1 | 1 | 1 unit | 101 | 0.190 |
| | | 1.5 | 2.8 ... 4 | 16 | A | 3RU11 16-1EC1 | 1 | 1 unit | 101 | 0.190 |
| | | 1.5 | 3.5 ... 5 | 20 | A | 3RU11 16-1FC1 | 1 | 1 unit | 101 | 0.190 |
| | | 2.2 | 4.5 ... 6.3 | 20 | A | 3RU11 16-1GC1 | 1 | 1 unit | 101 | 0.190 |
| | | 3 | 5.5 ... 8 | 25 | A | 3RU11 16-1HC1 | 1 | 1 unit | 101 | 0.190 |
| | 4 | 7 ... 10 | 35 | A | 3RU11 16-1JC1 | 1 | 1 unit | 101 | 0.190 | |
| | 5.5 | 9 ... 12 | 35 | A | 3RU11 16-1KC1 | 1 | 1 unit | 101 | 0.190 | |
| Size S0 for direct mounting¹⁾⁷⁾ | | | | | | | | | | |
|  3RU11 16-...D0 | S0 | 0.75 | 1.8 ... 2.5 | 10 | B | 3RU11 26-1CD0 | 1 | 1 unit | 101 | 0.190 |
| | | 1.1 | 2.2 ... 3.2 | 10 | B | 3RU11 26-1DD0 | 1 | 1 unit | 101 | 0.190 |
| | | 1.5 | 2.8 ... 4 | 16 | B | 3RU11 26-1ED0 | 1 | 1 unit | 101 | 0.190 |
| | | 1.5 | 3.5 ... 5 | 20 | B | 3RU11 26-1FD0 | 1 | 1 unit | 101 | 0.190 |
| | | 2.2 | 4.5 ... 6.3 | 20 | B | 3RU11 26-1GD0 | 1 | 1 unit | 101 | 0.190 |
| | | 3 | 5.5 ... 8 | 25 | B | 3RU11 26-1HD0 | 1 | 1 unit | 101 | 0.190 |
| | | 4 | 7 ... 10 | 35 | B | 3RU11 26-1JD0 | 1 | 1 unit | 101 | 0.190 |
| | | 5.5 | 9 ... 12.5 | 35 | B | 3RU11 26-1KD0 | 1 | 1 unit | 101 | 0.190 |
| | | 7.5 | 11 ... 16 | 40 | A | 3RU11 26-4AD0 | 1 | 1 unit | 101 | 0.190 |
| | | 7.5 | 14 ... 20 | 50 | A | 3RU11 26-4BD0 | 1 | 1 unit | 101 | 0.190 |
| | | 11 | 17 ... 22 | 63 | A | 3RU11 26-4CD0 | 1 | 1 unit | 101 | 0.190 |
| | | 11 | 20 ... 25 | 63 | A | 3RU11 26-4DD0 | 1 | 1 unit | 101 | 0.190 |
| | Size S2 for direct mounting¹⁾⁷⁾ | | | | | | | | | |
|  3RU11 36-...D0 | S2 | 3 | 5.5 ... 8 | 25 | B | 3RU11 36-1HD0 | 1 | 1 unit | 101 | 0.320 |
| | | 4 | 7 ... 10 | 35 | B | 3RU11 36-1JD0 | 1 | 1 unit | 101 | 0.320 |
| | | 5.5 | 9 ... 12.5 | 35 | B | 3RU11 36-1KD0 | 1 | 1 unit | 101 | 0.320 |
| | | 7.5 | 11 ... 16 | 40 | B | 3RU11 36-4AD0 | 1 | 1 unit | 101 | 0.320 |
| | | 7.5 | 14 ... 20 | 50 | B | 3RU11 36-4BD0 | 1 | 1 unit | 101 | 0.320 |
| | | 11 | 18 ... 25 | 63 | B | 3RU11 36-4DD0 | 1 | 1 unit | 101 | 0.320 |
| | | 15 | 22 ... 32 | 80 | A | 3RU11 36-4ED0 | 1 | 1 unit | 101 | 0.320 |
| | | 18.5 | 28 ... 40 | 80 | A | 3RU11 36-4FD0 | 1 | 1 unit | 101 | 0.320 |
| | | 22 | 36 ... 45 | 100 | A | 3RU11 36-4GD0 | 1 | 1 unit | 101 | 0.320 |
| | | 22 | 40 ... 50 | 100 | A | 3RU11 36-4HD0 | 1 | 1 unit | 101 | 0.320 |
| Size S3 for direct mounting¹⁾⁷⁾ | | | | | | | | | | |
|  3RU11 46-...D0 | S3 | 11 | 18 ... 25 | 63 | B | 3RU11 46-4DD0 | 1 | 1 unit | 101 | 0.550 |
| | | 15 | 22 ... 32 | 80 | B | 3RU11 46-4ED0 | 1 | 1 unit | 101 | 0.550 |
| | | 18.5 | 28 ... 40 | 80 | B | 3RU11 46-4FD0 | 1 | 1 unit | 101 | 0.550 |
| | | 22 | 36 ... 50 | 125 | B | 3RU11 46-4HD0 | 1 | 1 unit | 101 | 0.550 |
| | | 30 | 45 ... 63 | 125 | A | 3RU11 46-4JD0 | 1 | 1 unit | 101 | 0.550 |
| | | 37 | 57 ... 75 | 160 | A | 3RU11 46-4KD0 | 1 | 1 unit | 101 | 0.550 |
| | | 45 | 70 ... 90 | 160 | A | 3RU11 46-4LD0 | 1 | 1 unit | 101 | 0.550 |
| | | 45 | 80 ... 100 | 200 | A | 3RU11 46-4MD0 | 1 | 1 unit | 101 | 0.550 |

1) With the suitable terminal brackets (see Accessories) the 3RU11 overload relays for direct mounting can also be installed as stand-alone units.

2) Size S00 for screw and snap-on mounting onto TR35 standard mounting rail.

3) Observe maximum rated operational current of the devices.

4) Standard value for 4-pole standard motors at 50 Hz 400 V AC. The actual starting and rated data of the motor to be protected must be considered when selecting the units.

5) Maximum fuse for overload relay, type of coordination 2. For fuse values in conjunction with contactors, see Technical Specifications, Short-Circuit Protection with Fuses/Motor Starter Protectors for Motor Feeders.

6) Auxiliary and main conductor terminals with Cage Clamp connection.

7) Auxiliary conductor terminals with Cage Clamp connection and main conductor terminals with screw connection.

Overload Relays

3RU1 Thermal Overload Relays

Accessories





Overview

The following accessories are available for the 3RU11 thermal overload relays:

- For the four overload relay sizes S00 to S3 one terminal bracket each for stand-alone installation
- One electrical remote RESET module in three voltage variants for all sizes

- One mechanical RESET module for all sizes
- One cable release for resetting devices which are difficult to access (for all sizes)
- Terminal covers

Selection and ordering data



| Version | Size | DT | Order No. | Price per PU | PU (UNIT, SET, M) | PS* | PG | Weight per PU approx. kg | |
|---|---|---------------------|-------------------------|-------------------------|-------------------|--------|--------|--------------------------|-------|
| Terminal brackets for stand-alone installation | | | | | | | | | |
|  <p>3RU19 0.6-3AA01</p> | For separate mounting of overload relays; screw and snap-on mounting onto TH35 standard mounting rail; size S3 also for TH75 standard mounting rail | S00 | ▶ 3RU19 16-3AA01 | | 1 | 1 unit | 101 | 0.060 | |
| | | S0 | ▶ 3RU19 26-3AA01 | | 1 | 1 unit | 101 | 0.080 | |
| | | S2 | ▶ 3RU19 36-3AA01 | | 1 | 1 unit | 101 | 0.180 | |
| | | S3 | ▶ 3RU19 46-3AA01 | | 1 | 1 unit | 101 | 0.280 | |
| Mechanical RESET¹⁾ | | | | | | | | | |
|  <p>3RU19 00-1A with pushbutton and extension plunger</p> | Resetting plungers, holders and formers | S00 ...S3 | ▶ 3RU19 00-1A | | 1 | 1 set | 101 | 0.038 | |
| | Pushbuttons with extended stroke (12 mm), IP65, Ø 22 mm | | B | ▶ 3SB30 00-0EA11 | | 1 | 1 unit | 102 | 0.021 |
| | Extension plungers For compensation of the distance between a pushbutton and the unlatching button of the relay | | A | ▶ 3SX1 335 | | 1 | 1 unit | 102 | 0.004 |
| Cable releases with holder for RESET¹⁾ | | | | | | | | | |
|  <p>3RU19 00-1.</p> | For 6.5 mm Ø hole in the mounting plate; max. 8 mm control panel thickness | S00 ...S3 | | | | | | | |
| | <ul style="list-style-type: none"> • Length 400 mm • Length 600 mm | | ▶ 3RU19 00-1B | | 1 | 1 unit | 101 | 0.063 | |
| | | | ▶ 3RU19 00-1C | | 1 | 1 unit | 101 | 0.073 | |
| Modules for remote RESET, electrical | | | | | | | | | |
|  <p>3RU19 00-2A.71</p> | Operating range | 24 ... 30 V AC/DC | S00 ...S3 | ▶ 3RU19 00-2AB71 | | 1 | 1 unit | 101 | 0.066 |
| | 0.85 ... 1.1 × U _s , power consumption | 110 ... 127 V AC/DC | | ▶ 3RU19 00-2AF71 | | 1 | 1 unit | 101 | 0.067 |
| | 80 VA AC, 70 W DC, ON period | 220 ... 250 V AC/DC | | ▶ 3RU19 00-2AM71 | | 1 | 1 unit | 101 | 0.066 |
| 0.2 ... 4 s, operating frequency | | | | | | | | | |
| | 60/h | | | | | | | | |
| Terminal covers¹⁾ | | | | | | | | | |
| | Covers for cable lug and rail connections | | | | | | | | |
| | • Length 55 mm | S3 | ▶ 3RT19 46-4EA1 | | 1 | 1 unit | 101 | 0.037 | |
| | Covers for box terminals | | | | | | | | |
| | • Length 20.6 mm | S2 | ▶ 3RT19 36-4EA2 | | 1 | 1 unit | 101 | 0.016 | |
| | • Length 20.8 mm | S3 | ▶ 3RT19 46-4EA2 | | 1 | 1 unit | 101 | 0.023 | |

1) The accessories are identical to those of the 3RB2 solid-state overload relays.

Overload Relays

3RU1 Thermal Overload Relays

Accessories

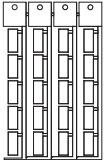
| Version | Size/Color | Use | DT | Order No. | Price per PU | PU (UNIT, SET, M) | PS* | PG | Weight per PU approx. kg |
|--|--|---|--|-----------|-----------------------|-------------------|-----|------------|--------------------------|
| Tools for opening Cage Clamp terminals | | | | | | | | | |
|  | 3.5 x 0.5 mm, suitable for a max. conductor cross-section of 2.5 mm ² | Length approx. 175 mm; green; partially insulated | SIRIUS units with spring-loaded/Cage Clamp connections | A | 8WA2 880 | | 1 | 1 unit | 041 0.012 |
| 8WA2 880 | | | | | | | | | |
|  | | Length approx. 175 mm; green | | A | 8WA2 803 | | 1 | 1 unit | 041 0.024 |
| 8WA2 803 | | | | | | | | | |
|  | 2.5 x 0.4 mm, suitable for a max. conductor cross-section of 1.5 mm ² | Length approx. 160 mm; green | | A | 8WA2 807 | | 1 | 1 unit | 041 0.023 |
| 8WA2 807 | | | | | | | | | |
| Blank labeling plates | | | | | | | | | |
|  | Device labeling plates | 10 mm x 7 mm | 3RU11, pastel turquoise | D | 3RT19 00-1SB10 | | 100 | 816 units | 101 0.240 |
| | For SIRIUS devices | 20 mm x 7 mm | 3RB2 pastel turquoise | C | 3RT19 00-1SB20 | | 100 | 340 units | 101 0.220 |
| | Labeling plates for sticking (labels) | 19 mm x 6 mm | 3RU11, pastel turquoise | D | 3RT19 00-1SB60 | | 100 | 3060 units | 101 0.155 |
| | For SIRIUS devices | 19 mm x 6 mm | 3RB2 zinc yellow | C | 3RT19 00-1SD60 | | 100 | 3060 units | 101 0.120 |
| <p>PC labeling system For individual inscription of device labeling plates Obtainable from: murrplastik Systemtechnik GmbH http://www.murrplastik.com</p> | | | | | | | | | |