

Type: **P3-100/I5/SVB**
 Article No.: **207373**

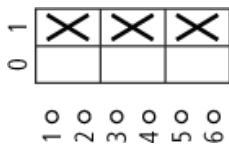

Ordering information			
Design			Surface mounting
Description			Without auxiliary contacts
Main conducting paths No. of poles		M	3
Auxiliary contacts		N/O	0
Auxiliary contacts		B	0
Max. three-phase motor rating (per set of 3 contacts) 50–60 Hz AC–3 400/415 V 50–60 Hz	<i>P</i>	kW	50
Rated uninterrupted current	<i>I_u</i>	A	100
Note for table header			According to IEC/EN 60204–1, VDE 0113 Part 1; with red rotary handle and yellow locking collar, lockable in 0 position

Contact sequence



General			
Standards			IEC/EN 60947, VDE 0660, IEC/EN 60204, CSA,UL Switch-disconnectors to IEC/EN 60947–3
Lifespan, mechanical	Operations	$\times 10^6$	0,1

Maximum operating frequency	Operations/h		50
Climatic proofing			Damp heat, constant, to IEC 60068–2–78; Damp heat, cyclical, to IEC 60068–2–30
Ambient temperature			
Open		°C	–25/50
Enclosed		°C	–25/40
Mounting position			As required
Documentation			Main catalogue HPL
Mechanical shock resistance (shock duration 20 ms)		g	> 15

Contacts

Rated operational voltage	U_e	V AC	690
Rated impulse withstand voltage	U_{imp}	V AC	6000
Overvoltage category/pollution degree			III/3
Rated uninterrupted current			
open	I_u	A	100
Enclosed	I_u	A	100
Load-carrying capacity in intermittent operation, Class 12			
AB 25 % DF		$\times I_e$	2
AB 40 % DF		$\times I_e$	1,6
AB 60 % DF		$\times I_e$	1,3
Short-circuit rating			
Fuse		A gG/gL	100
Rated short-time withstand current (1 s current)	I_{cw}	A_{rms}	2000
Switching angles		°	90
Current heat loss per contact at I_e		W	7,5

Terminal capacities

Solid or stranded		mm ²	1 × (2.5 – 35) 2 × (2.5 – 10)
Flexible with ferrule to DIN 46228		mm ²	1 × (1.5 – 25) 2 × (1.5 – 6)
Terminal screw			M5
Tightening torque		Nm	3

Switching capacity

AC			
Rated making capacity $\cos \phi = 0.35$		A	950

Rated breaking capacity, motor load switch $\cos = 0.35$			
230 V		A	760
400 V		A	740
500 V		A	880
690 V		A	520
Rated operational current 440 V load-break switch AC-21A	I_e	A	100
AC-3 motor load switch motor rating			
230 V	P	kW	22
400 V	P	kW	37
500 V	P	kW	45
690 V	P	kW	37
AC-23A Motor load switches (main switches maintenance switches)			
230 V	P	kW	30
400 V	P	kW	50
500 V	P	kW	65
690 V	P	kW	45
DC			
DC-1, Load-break switches L/R = 1 ms			
Rated operational current	I_e	A	100
Voltage per contact pair in series		V	60
DC-23A, Motor load switches L/R = 15 ms			
24 V			
Rated operational current	I_e	A	50
Contacts		Quantity	1
48 V			
Rated operational current	I_e	A	50
Contacts		Quantity	2
60 V			
Rated operational current	I_e	A	50
Contacts		Quantity	3
120 V			
Rated operational current	I_e	A	25
Contacts		Quantity	3

Notes			
			<p>Main switch characteristics to IEC/EN 60204; positive opening of contacts, operator element positively located on shaft</p> <p>The rated uninterrupted current I_u is stated at max. connected cross-section.</p> <p>For terminal capacity solid, stranded and flexible: Max. 2 cross-section sizes difference admissible when using 2 conductors.</p>
Dimensions			
			3 Padlocks
Explanation			<p>For utilisation category AC-4 (extreme load: 100 % inching, reversing or plugging)</p> <p>The blocked rotor current of the motor should not exceed the rated current of the switch for AC-21A to ensure a reasonable device lifespan.</p>

Dimensions

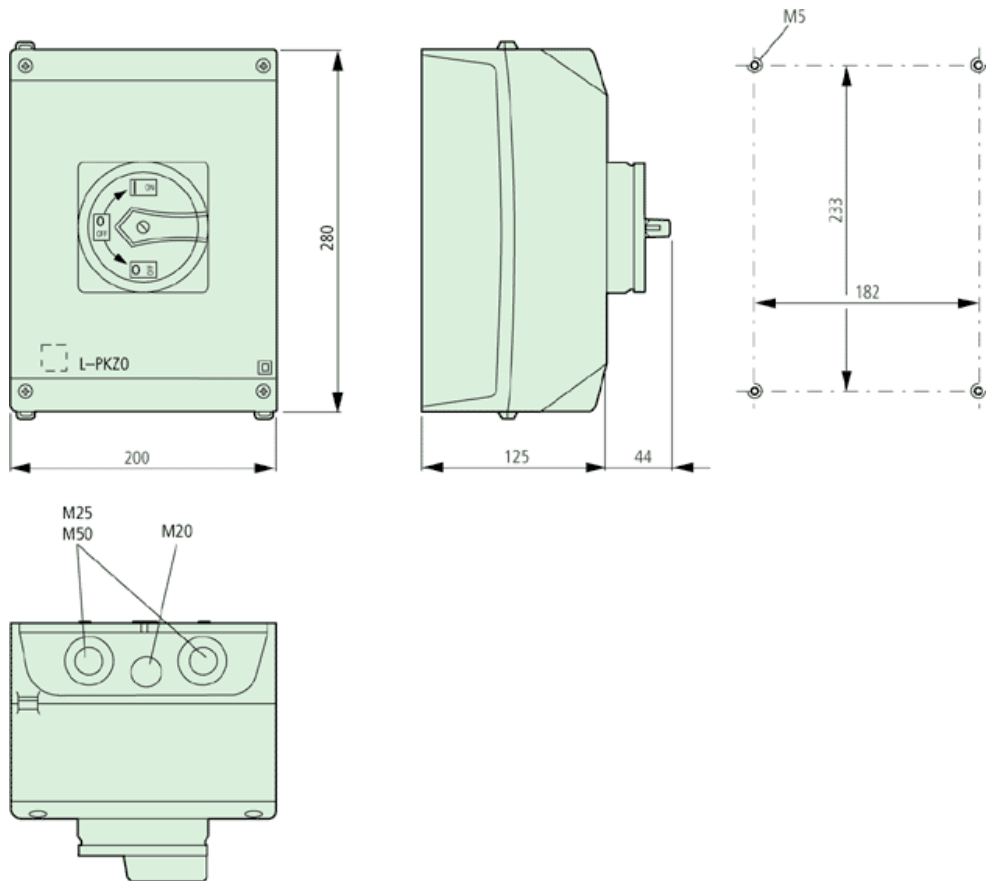

Dimensions

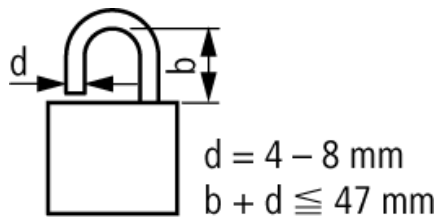

Characteristic curve

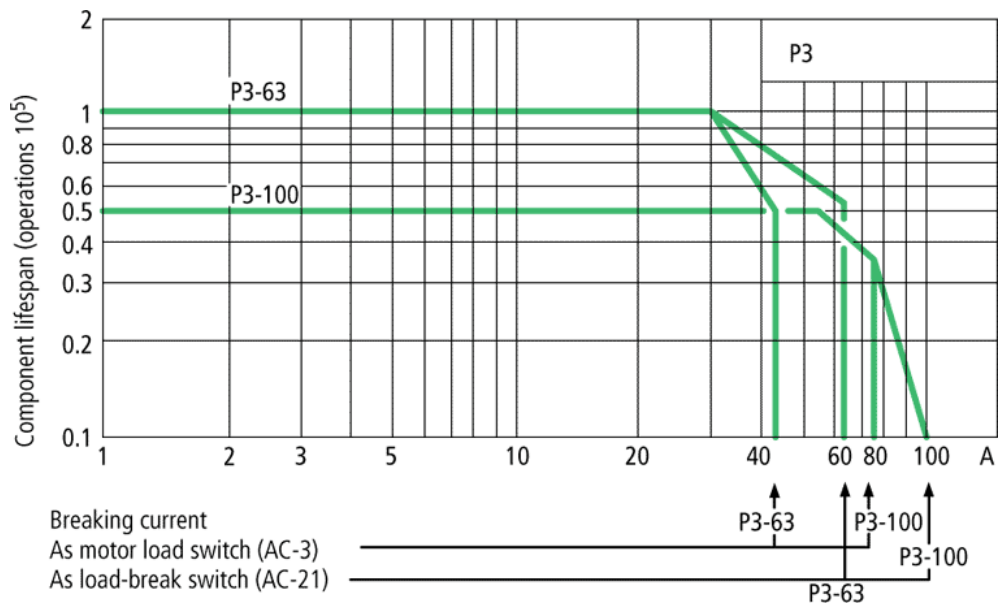

Moeller GmbH, Hein-Moeller-Str. 7-11, D-53115 Bonn
 E-Mail: catalog@moeller.net, Internet: www.moeller.net, <http://catalog.moeller.net>
 Copyright 2006 by Moeller GmbH. Subject to modifications. HPL-C2006GB-INT V2.3