

MCR-C-UI-UI(-450)-DCI(-NC)

3-way isolation amplifier

INTERFACE

Data Sheet
100238_en_02

© PHOENIX CONTACT - 01/2008



Description

The MCR-C-UI-UI(-450)-DCI(-NC) 3-way isolation amplifier is used to electrically isolate and convert analog signals. The device provides electrical isolation of analog standard signals. The module input and output are supplied via integrated DC/DC converters, which are electrically isolated from the mains (3-way isolation).

The required auxiliary voltage is indicated via a green power LED. This clearly indicates whether or not auxiliary voltage is available.

The MCR module ensures the safe decoupling of a sensor circuit from the evaluation circuit and also prevents the negative effects of several sensor circuits connected with one another. 3-way isolation enables the universal use of modules both locally and close to the control system for signal conversion and electrical isolation, as well as on the transmission path for jumpering high load resistors.

Signals are converted by an inductive transmission method. In addition, a filter connected downstream of the transmitter reduces possible interference.

Features

- Configurable 3-way isolating amplifiers
- Input and output signal range can be configured via DIP switches
- ZERO/SPAN adjustment using potentiometers
- Can be supplied configured or unconfigured



WARNING: Correct usage in potentially explosive areas

The module is a category 3 item of electrical equipment. Follow the instructions provided here during installation and observe the safety instructions.



Make sure you always use the the latest documentation.
It can be downloaded at www.download.phoenixcontact.com.
A conversion table is available on the Internet at
www.download.phoenixcontact.com/general/7000_en_00.pdf



This data sheet is valid for all products listed on the following page:

Ordering data

Description	Type	Order No.	Pcs./Pkt.
3-way isolation amplifier , Pluggable COMBICON screw connection , with a limit frequency (3 dB) 30 Hz, configured	MCR-C-UI-UI-DCI	2810913	1
3-way isolation amplifier , Pluggable COMBICON screw connection , with limit frequency (3 dB) 450 Hz, without GL and UL approval, configured	MCR-C-UI-UI-450-DCI	2810887	1
3-way isolation amplifier , Pluggable COMBICON screw connection , with a limit frequency (3 dB) 30 Hz, unconfigured	MCR-C-UI-UI-DCI-NC	2810939	1

Order key (standard configuration entered as an example)

Order No.	Input	Output	Factory Calibration Certificate		
2810913	IN03	OUT03	NONE		
2810913 ≙ MCR-C-UI-UI-DCI	IN01 ≙ 0 ... 20 mA IN02 ≙ 4 ... 20 mA IN03 ≙ 0 ... 10 V IN05 ≙ 0 ... 5 V IN06 ≙ 1 ... 5 V IN13 ≙ -60 ... +60 mV IN14 ≙ -100 ... +100 mV IN15 ≙ -200 ... +200 mV IN16 ≙ -300 ... +300 mV IN17 ≙ -500 ... +500 mV	IN18 ≙ -1 ... +1 V IN19 ≙ -2 ... +2 V IN20 ≙ -2.5 ... +2.5 V IN21 ≙ -5 ... +5 V IN22 ≙ -10 ... +10 V IN23 ≙ -20 ... +20 V IN24 ≙ 0 ... 60 mV IN25 ≙ 0 ... 100 mV IN26 ≙ 0 ... 200 mV IN27 ≙ 0 ... 300 mV	IN28 ≙ 0 ... 500 mV IN29 ≙ 0 ... 1 V IN30 ≙ 0 ... 2 V IN31 ≙ 0 ... 2.5 V IN32 ≙ 0 ... 20 V IN33 ≙ -5 ... +5 mA IN34 ≙ -10 ... +10 mA IN35 ≙ -20 ... +20 mA IN36 ≙ 0 ... 5 mA IN37 ≙ 0 ... 10 mA	OUT01 ≙ 0 ... 20 mA OUT02 ≙ 4 ... 20 mA OUT03 ≙ 0 ... 10 V OUT05 ≙ 0 ... 5 V OUT06 ≙ 1 ... 5 V OUT13 ≙ -5 ... +5 V OUT14 ≙ -10 ... +10 V OUT15 ≙ 0 ... 5 mA OUT16 ≙ 0 ... 10 mA	NONE ≙ Without factory calibration certificate YES ≙ With factory calibration certificate (a fee is charged) YESPLUS ≙ Factory calibration certificate with 5 measuring points (a fee is charged)

Combination Table for Input and Output Signals

Input	Voltage Output					Current Output			
	0 ... 10 V	±10 V	0 ... 5 V	±5 V	1 ... 5 V	0 ... 5 mA	0 ... 10 mA	0 ... 20 mA	4 ... 20 mA
0 ... 60 mV	x	x	x	x	x	x	x	x	x
0 ... 100 mV	x	x	x	x	x	x	x	x	x
0 ... 200 mV	x	x	x	x	x	x	x	x	x
0 ... 300 mV	x	x	x	x	x	x	x	x	x
0 ... 500 mV	x	x	x	x	x	x	x	x	x
0 ... 1 V	x	x	x	x	x	x	x	x	x
0 ... 2 V	x	x	x	x	x	x	x	x	x
0 ... 2.5 V	x	x	x	x	x	x	x	x	x
0 ... 5 V	x	x	x	x	x	x	x	x	x
0 ... 10 V	x	x	x	x	x	x	x	x	x
0 ... 20 V	x	x	x	x	x	x	x	x	x
±60 mV	x	x	x	x			x	x	
±100 mV	x	x	x	x			x	x	
±200 mV	x	x	x	x			x	x	
±300 mV	x	x	x	x			x	x	
±500 mV	x	x	x	x			x	x	
±1 V	x	x	x	x			x	x	
±2 V	x	x	x	x			x	x	
±2.5 V	x	x	x	x			x	x	
±5 V	x	x	x	x			x	x	
±10 V	x	x	x	x			x	x	
±20 V	x	x	x	x			x	x	
0 ... 5 mA	x	x	x	x	x	x	x	x	x
0 ... 10 mA	x	x	x	x	x	x	x	x	x
0 ... 20 mA	x	x	x	x	x	x	x	x	x
±5 mA	x	x	x	x			x	x	
±10 mA	x	x	x	x			x	x	
±20 mA	x	x	x	x			x	x	
1 ... 5 V	x	x	x	x	x		x	x	x
4 ... 20 mA	x	x	x	x	x		x	x	x

Technical data

Signal input	
Configurable/programmable MCR-C-UI-UI-DCI MCR-C-UI-UI-450-DCI	Yes, preconfigured
Configurable/programmable MCR-C-UI-UI-DCI-NC	Yes, unconfigured
Voltage input signal	0 V ... 10 V (please indicate any different setting when ordering)
Max. voltage input signal	30 V
Max. current input signal	50 mA
Input resistance of voltage input	1 M Ω
Input resistance current input	50 Ω
Signal output	
Voltage output signal	0 V ... 10 V (please indicate any different setting when ordering)
Max. voltage output signal	15 V
Max. current output signal	30 mA
Configurable/programmable MCR-C-UI-UI-DCI MCR-C-UI-UI-450-DCI	Yes, preconfigured
Configurable/programmable MCR-C-UI-UI-DCI-NC	Yes, unconfigured
Load/output load voltage output	≥ 10 k Ω
Load/output load current output	≤ 500 Ω
Power supply	
Supply voltage range	18 V DC ... 30 V DC
Max. current consumption	< 30 mA (without load)
General data	
Limit frequency (3 dB) MCR-C-UI-UI-DCI MCR-C-UI-UI-DCI-NC	30 Hz
Limit frequency (3 dB) MCR-C-UI-UI-450-DCI	450 Hz
Measuring principle	Signal isolator
Transmission error, max.	≤ 0.1 % (of end value)
Maximum temperature coefficient	0.0075 %/K
Alignment zero	± 2 %
Alignment span	± 2 %
Step response (10-90%)	11 ms
Mounting position	Any
Degree of protection	IP20
Dimensions W / H / D	17.5 mm / 99 mm / 114.5 mm
Type of housing	Polyamide PA non-reinforced green
Connection data	
Conductor cross section, solid	0.2 mm ² ... 2.5 mm ²
Conductor cross section, stranded	0.2 mm ² ... 2.5 mm ²
Stripping length	8 mm

Safe isolation

Test voltage input/output	1.5 kV (50 Hz, 1 min.)
Test voltage power supply/signal	1 kV (50 Hz, 1 min.)

Ambient conditions

Ambient temperature (operation)	-20 °C ... 65 °C
---------------------------------	------------------

Conformance / approvals

Conformance	CE compliant
UL, USA / Canada	Class I, Div. 2, Groups A, B, C, D or non-hazardous locations
GL	Germanischer Lloyd

Conformance with EMC directive 2004/108/EC

Noise immunity according to EN 61000-6-2

Electrostatic discharge	EN 61000-4-2
Electromagnetic HF field	EN 61000-4-3
Fast transients (burst)	EN 61000-4-4
Surge current loads (surge)	EN 61000-4-5
Conducted interference	EN 61000-4-6

Noise emission according to EN 61000-6-4

Noise emission according to EN 61000-6-4	EN 55011	Class A
--	----------	---------

Block diagram

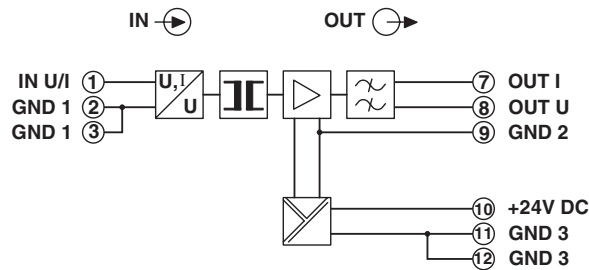

Safety notes

**WARNING: Correct usage in potentially explosive areas**

The module is a category 3 item of electrical equipment. Follow the instructions provided here during installation.

Install the module in housing with IP54 protection according to EN 60529. The specified limits for mechanical strain or thermal loads for the module must not be exceeded.

Only modules suitable for operation in zone 2 potentially explosive areas may be connected.

Repairs must not be carried out by the user.

In potentially explosive areas, snap the module onto the DIN rail and connect the cables only when the power is disconnected.

**CAUTION**

Installation, operation, and maintenance may only be carried out by qualified electricians. When installing and operating the device, the applicable safety directives (including national directives), accident prevention regulations, as well as general technical regulations, must be observed.

**CAUTION: Electrostatic discharge**

The module contains components that can be damaged or destroyed by electrostatic discharge. When handling the module, observe the necessary safety precautions against electrostatic discharge (ESD) according to EN 61340-5-1 and EN 61340-5-2.

Structure

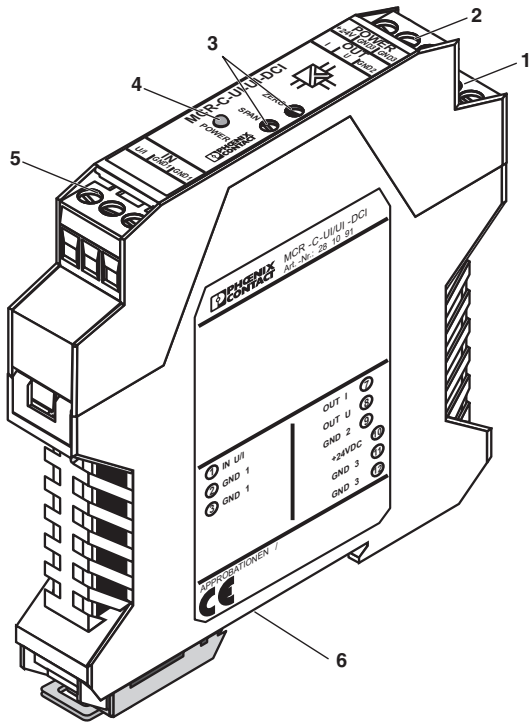

DIP switches S1 and S2 are located inside the housing.

- 1 Supply voltage
- 2 Output: Standard signals
- 3 "ZERO" and "SPAN" potentiometers
- 4 "POWER" LED
- 5 Input: Standard signals
- 6 Universal snap-on foot for EN DIN rails

Power supply

Power Supply via the Connection Terminal Blocks

The current measuring transducer is connected to the power supply at the "+24VDC" and "GND" connection terminal blocks (see block diagram).

Installation

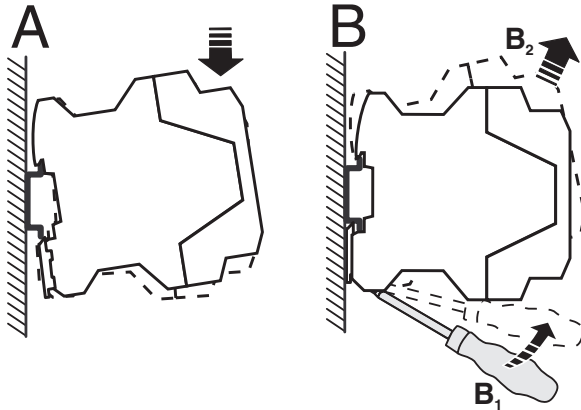

WARNING

In potentially explosive areas, snap the module onto the DIN rail and connect the cables only when the power is disconnected.

The assignment of the connection terminal blocks is shown in the block diagram. The module can be snapped onto all 35 mm DIN rails according to EN 60715.

Assembly

Position the module with the DIN rail guide on the upper edge of the DIN rail, and snap it in with a downward motion.

Removing

Pull the snap lever open with the aid of a screwdriver and slide the module out at the lower edge of the DIN rail.

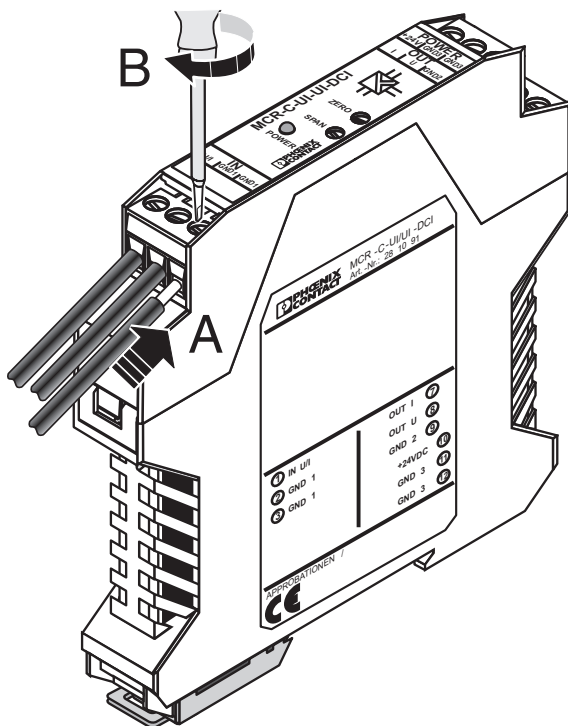

Screw Connection

Insert the wires in the corresponding connection terminal block.

Use a screwdriver to tighten the screw in the opening above the connection terminal block.

Configuration

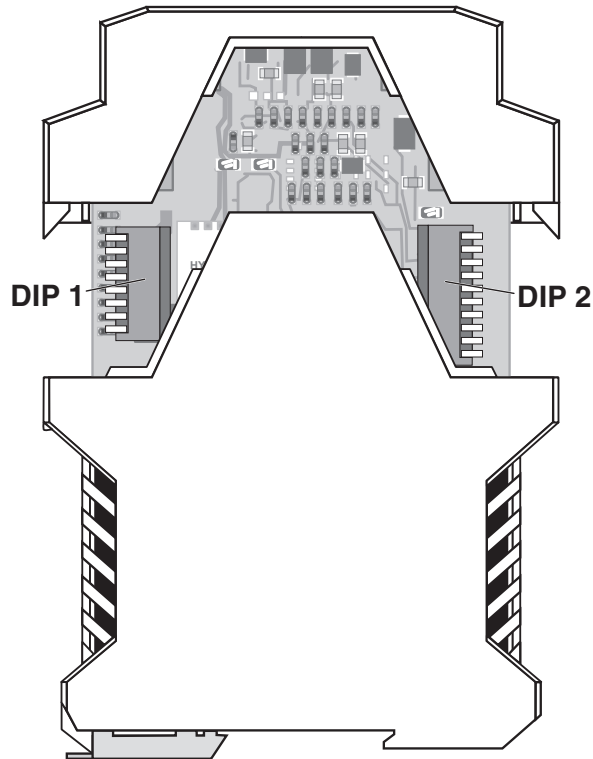

CAUTION: Electrostatic discharge

The module contains components that can be damaged or destroyed by electrostatic discharge. When handling the module, observe the necessary safety precautions against electrostatic discharge (ESD) according to EN 61340-5-1 and EN 61340-5-2.

If the modules are not configured (all DIP switches set to pos. 0), the module does not have a defined function until the DIP switches have been set.

DIP switches S1 and S2 specify the combination of input and output standard signal ranges (see configuration table).

Standard Configuration

"NC" versions (...-NC) have the following standard configuration:

- 0 ... 10 V input
- 0 ... 10 V output

(All DIP switches are set to the "OFF" position)

Opening the Module

Using a screwdriver, release the locked upper part of the housing on both sides. The upper part of the housing and the electronics can now be pulled out approximately 3 cm.

Adjustment

The "ZERO" potentiometer is used to adjust the zero point of the module and the "SPAN" potentiometer is used to adjust the final value. Both potentiometers are located on the top of the module.



ATTENTION: Module can become damaged

Before commencing the adjustment process, observe the warm-up phase of two minutes.

Specifying the Input Signal Range via DIP Switch 1

Select one of the possible signal ranges using the appropriate configuration of DIP switch 1 according to the table.
Exception: Bipolar input signals are not permitted for the 4 ... 20 mA and 1 ... 5 V output signal ranges.

Specifying the Output Signal Range via DIP Switch 2

Output With Simple Adjustment (0 ... 5 V/0 ... 10 V)

Set the output range via DIP switch 2. Please note the selected input range. Specify the initial and final value of the input signal using a calibration device. Adjust the output value with a digital multimeter.

Adjustment after specifying the initial and final value for the 0 ... 5 V output: Set 0 V \pm 0.5 mV at the "ZERO" potentiometer and 5 V \pm 0.5 mV at the "SPAN" potentiometer.

Adjustment after specifying the initial and final value for the 0 ... 10 V output: Set 0 V \pm 0.5 mV at the "ZERO" potentiometer and 10 V \pm 0.5 mV at the "SPAN" potentiometer.

**Output With Adjustment Point Calculation (± 5 V/ ± 10 V/
1 ... 5 V/0 ... 5 mA/0 ... 10 mA/0 ... 20 mA/4 ... 20 mA)**

Set the output range via DIP switch 2. Please note the selected input range.

Specify the initial and final value of the input signal using a calibration device.

Record the output value measured with a digital multimeter.

For adjustment with the calibration device, specify the final value of the input signal range as follows:

"SPAN" potentiometer: Full-scale adjustment point A \pm adjustment tolerance

"ZERO" potentiometer: Output final value \pm adjustment tolerance

Calculation of full-scale adjustment point A: $A = \text{Measured value 1} \times \text{Constant} / \text{Measured value 2} - \text{Measured value 1}$

± 5 V, ± 10 V, 1 ... 5 V, 4 ... 20 mA output signal ranges: If the initial value is specified at the input, measured value 1 is output at the output. If the final value is specified at the input, measured value 2 is output at the output.

0 ... 20 mA output signal range: If the initial value +10% of the range is specified at the input, measured value 1 is output at the output. If the final value is specified at the input, measured value 2 is output at the output.



For the values for the constant, output final value, and adjustment tolerance, please refer to the corresponding tables.

Connection example

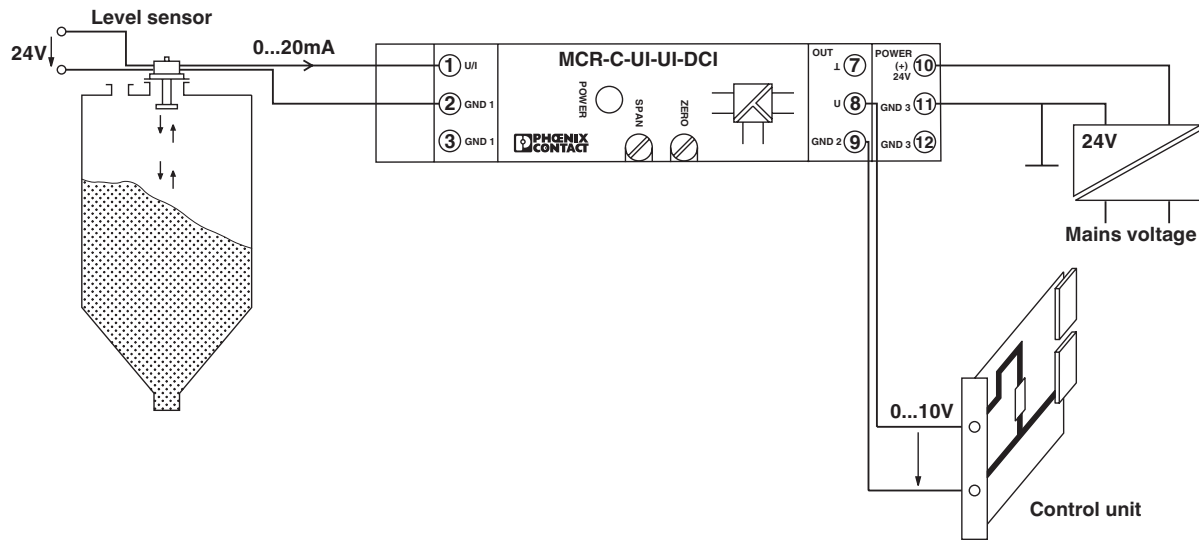

Application example: Level measurement