



24 V DC:

- 1-channel
- Control circuit EEx ia IIC
- Reversible mode of operation
- 1 relay output with 1 changeover contact
- EMC acc. to NAMUR NE 21
- LB/SC monitoring
- LB/SC combined error signal via Power Rail

Function

The transformer isolated barrier transfers digital signals from the hazardous area. Sensors per DIN EN 60947-5-6 (NAMUR) and mechanical contacts may be used as alarms. Control circuits are monitored for lead breakage (LB) and short circuit (SC). The external faults are indicated according to NAMUR NE44 by a red flashing LED. For type KFD2-SR2-Ex1.W, an LB/SC combined error signal is in addition transferred through the Power Rail to the power feed module. The intrinsically safe input is per DIN EN 50020 safely isolated from the output and the power supply. The relay output is in accordance with DIN EN 0106 section 101 safely isolated from the power supply.

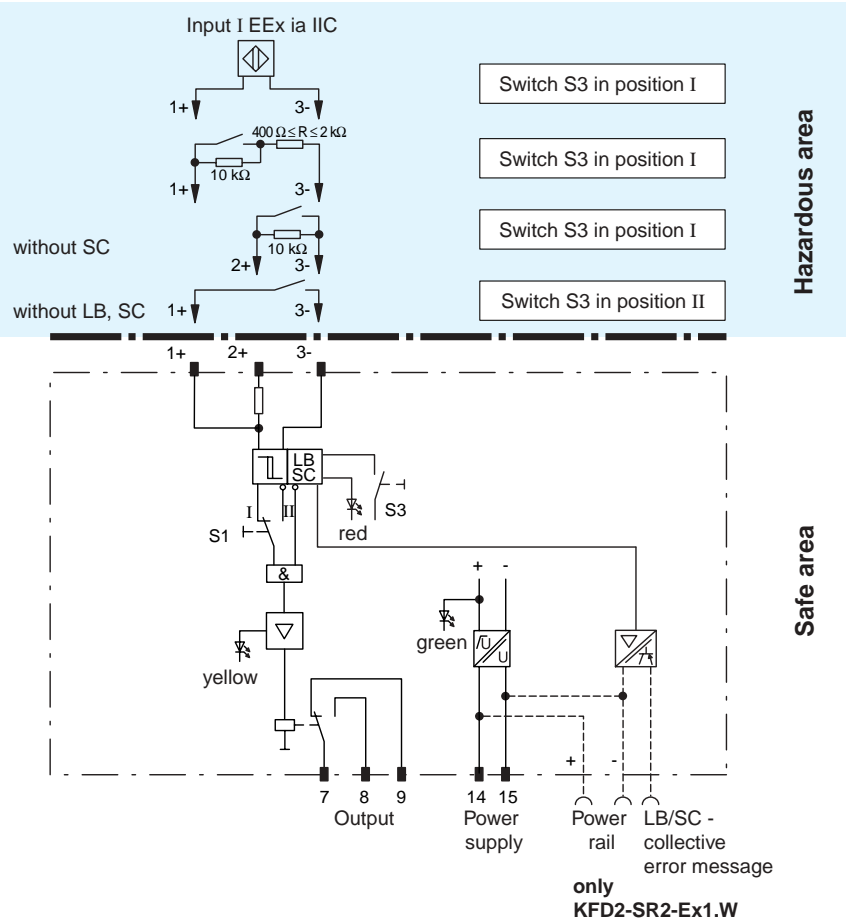

Construction

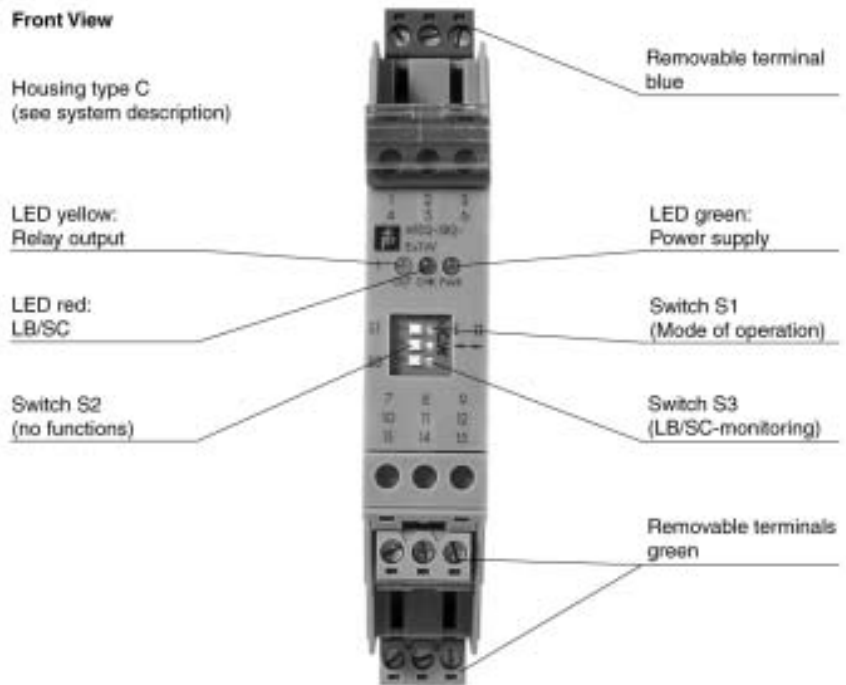

Power supply

Connection type	Power Rail or terminals 14+, 15-
Rated operational voltage	20 ... 30 V DC
Rated operational current	20 ... 23 mA
Safety maximum voltage U_m	40 V DC
Ripple	≤ 10 %

Input (intrinsically safe)

Connection type	terminals 1+, 2+, 3-
Nominal data	in accordance with IEC 60947-5-6 (NAMUR, DIN 19234); see system description for electrical data
Quiescent voltage/Short-circuit current	approx. 8 V DC / approx. 8 mA
Switching point/Switching hysteresis	1.2 ... 2.1 mA / approx. 0.2 mA
Input pulse length/Input pulse interval	≥ 20 ms / ≥ 20 ms
Lead monitoring	breakage $J \leq 0.1$ mA , short-circuit $J > 6$ mA

Details of certificate of conformity

Certification number	PTB 00 ATEX 2080 ; for additional certifications refer to the approval list		
Group, category, ignition protection method	⊕ II (1) G D [EEx ia] IIC		
Voltage U_0	10.5 V		
Current I_0	13 mA		
Power P_0	34 mW		

Allowable circuit values

Ignition protection class, category [EEx ia and EEx ib]

Explosion group	IIA	IIB	IIC
External capacitance	75 μF	16.8 μF	2.41 μF
External inductance	1000 mH	840 mH	210 mH

Entity parameter

Certification number	J.I.3002773		
FM control drawing	No. 116-0035		
Suitable for installation in division 2	yes		
Connection type	terminals 1, 3; 2, 3; 4, 6; 5, 6		
Input I			
Voltage V_{OC}	12.9 V		
Current I_{SC}	19.8 mA		
Explosion group	A&B	C&E	D, F&G
Max. external capacitance C_a	1.273 μF	3.82 μF	10.18 μF
Max. external inductance L_a	84.8 mH	254.4 mH	678.4 mH

Safety parameter

UL control drawing	E 106378
CSA control drawing	LR 36087-13
Control drawing	No. 116-0047
Connection type	terminals 1, 3; 2, 3; 4, 6; 5, 6

Input I

Safety parameter	12.6 V / 650 Ohm		
Voltage V_{OC}	12.9 V		
Current I_{SC}	19.8 mA		
Explosion group	A&B	C&E	D, F&G
Max. external capacitance C_a	1.273 μF	3.82 μF	10.18 μF
Max. external inductance L_a	84.88 mH	298.7 mH	744.4 mH

Output (not intrinsically safe)

Connection type	terminals 7, 8, 9
Output	signal ; relay
Contact loading	253 V AC / 2 A / $\cos \varphi > 0.7$; 40 V DC / 2 A ohmic load; from january 2002 increase of the contact rating to 4 A for 115 V AC switching voltage. The respective connection data are shown on the type plate.
Mechanical life	10 ⁷ switchings
Energized/De-energized delay	approx. 20 ms / approx. 20 ms

Transfer characteristics

Switching frequency	< 10 Hz
---------------------	---------

Galvanic isolation

Input/Output	safe galvanic isolation acc. to EN 50020, voltage peak value 375 V
Input/Power supply	safe galvanic isolation acc. to EN 50020, voltage peak value 375 V

06.03.2002
103367_eng

Output/Power supply	safe isolation acc. to DIN VDE 0106, design isolation voltage 253 V _{eff}
Ambient conditions	
Ambient temperature	-20 ... 60 °C (253 ... 333 K)
Standard conformity	
Input	in accordance with IEC 60947-5-6 (NAMUR, DIN 19234); see system description for electrical data
Coordination of insulation	accord. to DIN EN 50178
Galvanic isolation	accord. to DIN EN 50178
Climatic conditions	accord. to DIN IEC 721
Electromagnetic compatibility	accord. to EN 50081-2 / EN 50082-2, NAMUR NE 21
Mechanical specifications	
Mass	approx. 150 g

Accessories:

Power Rail PR 05

Power Rail UPR 05

Power feed module KFD2-EB2

The devices are supplied with 24 V DC due to the power feed module KFD2-EB2 and via the Power Rail PR 05 or UPR 05, simultaneously the combined fault indication will be evaluated.

Each power feed module serves the fusing and monitoring of groups with up to 100 single devices. The PR 05 Power Rail is an inset component for the DIN rail. The UPR 05 Power Rail is a complete unit consisting of the electrical insert and an aluminum 35 x 15 x 2000 mm DIN rail. Devices are simply snapped onto it for an electrical connection.

Without the use of a Power Rail, the power supply to the device is directly through the device terminals.

06.03.2002

103367_eng