

WV168-2000 (non-latching)
WV168-2001 (latching)

ULTRA SLIMPAK® II

WV168

DC Powered AC Input Limit Alarm

Provides Relay Contact Closures
at a Preset AC Input Level



- Programmable HI or LO, Failsafe or Non-failsafe
- Improved Accuracy
- Adjustable Deadband
- Bussed Power with Plug-in Power Clips
- Removable Terminals for Easy Service

- Touch Cal for Best Stability and Accuracy
- RoHS Compliant
- LED Trip and Input Indicators
- Optional E-mail Notification of Alarms

Description

The Ultra SlimPak II is an exciting new line of isolating signal conditioners from Action Instruments with greater accuracy and better stability than virtually any other signal conditioners on the market today.

The WV168 is an AC Voltage or Current Input Limit Alarm with dual setpoints and two contact closure outputs. The input type and alarm functions are field configurable, offering maximum flexibility. There are eight input voltage ranges between 50mV and 250V, and two current input ranges, 20mA and 100mA. Alarm setpoints are fully adjustable throughout the entire range.

The WV168-2000 contains two standard non-latching SPDT relays. When power is removed, the relays revert to their non-powered state. The WV168-2001 contains two latching relays. Whatever position the relays are in when power is removed is where they will remain when power is re-applied (a reset switch is provided to reset the relays after the alarm is no longer true). Both models are configurable as a single or dual setpoint alarm, with HI or LO trips. The WV168-2000 supports failsafe or non-failsafe operation. In failsafe operation the relay coil is energized when the process is below the HI setpoint or above the LO setpoint (opposite for non-failsafe). In the failsafe mode, a power failure results in an alarm state output.

Operation

Each of the alarm setpoints has a respective HI or LO deadband. Red LEDs will illuminate indicating an alarm condition. The trip will reset only when the process falls below the HI deadband or rises above the LO deadband. (The WV168-2001 requires pressing the reset switch in order to reset the relay after being tripped.) The deadband can be left at the minimum level (the factory default) or can be set to whatever level is desired.

Options

C620 Factory cal of input range, setpoints and output relays.

Enhanced LED Diagnostics

Other than when executing the pushbutton calibration routine, the LEDs blink under the following conditions:

RUN (Green):

- On when unit is powered.
- Flashes at 2Hz when input is under range.
- Flashes at 8Hz when input is over range.

SETPOINT A (Red):

- On when Setpoint A is tripped.
- On when setting Setpoint A.
- Flashes while calibrating the input level.

SETPOINT B (Red):

- On when Setpoint B is tripped.
- On when setting Setpoint B.
- On while calibrating the input level.

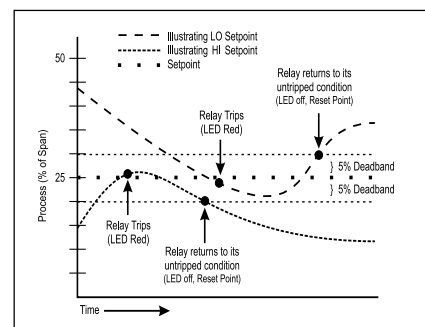

Figure 1: Limit alarm operation and effect of deadband.

An Under Range condition exists when the signal is lower than the operational low value minus 6.25% of the operational span. An Over Range condition exists when the signal is higher than the operational high value plus 6.25% of the operational span.

Configuring Modules

Unless otherwise specified, the factory presets the Model WV168 as follows:

- Input: mVAC
- Range: 0-500mV
- Output: Dual, SPDT
- Trip: A: HI, B: LO
- Failsafe: No
- Deadband: A, B: minimum
- Failsafe: Off

1. For other ranges, refer to the SWITCH SETTINGS table. Reconfigure switches S1 and S2 for the desired input type and range.
2. Set position 1 of S1 to ON if a WVC16 will be utilized and remote calibration capability is desired.
3. Set position 2 and 3 of S1 to ON for a Hi trip setpoint or to OFF for a Low trip setpoint.
4. Set position 4 of S1 to ON for failsafe operation (e.g. alarm trips upon power failure) or OFF for non-failsafe operation (-2000 only).

It is also possible to remotely select the setpoints using an Ethernet connection and the optional WVC16 WebView Communications Interface module.

Relay Protection and EMI Suppression

When switching inductive loads, maximum relay life and transient EMI suppression is achieved using external protection (see Figures 2 & 3). Place all protection devices directly across the load and minimize all lead lengths. For AC inductive loads, place a properly-rated MOV across the load in parallel with a series RC snubber. Use a 0.01 to 0.1mF pulse film capacitor (foil polypropylene recommended) of sufficient voltage, and a 47ohm 1/2W carbon resistor. For DC inductive loads, place a diode across the load (PRV > DC supply, 1N4006 recommended) with (+) to cathode and (-) to anode (the RC snubber is an optional enhancement).

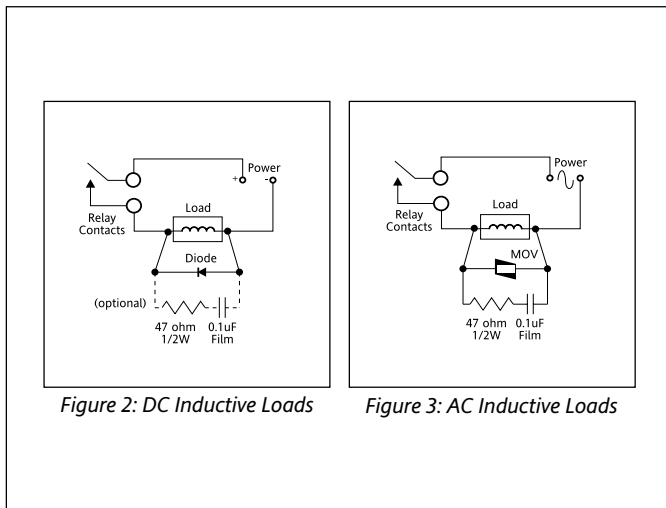

Calibration

See the calibration flowchart in Figure 6. The complete calibration procedure is contained in the Installation & Calibration Instructions document, which is available on our website (www.actionio.com). You can also obtain it by telephoning Action technical support (703-669-1318).

Note that Custom Calibration (option C620) is available from the factory (settings **MUST** be within the units specifications). For a C620, specify the following:

- a) Input type.
- b) Setpoint A trip point and reset point.
- c) Setpoint B trip point and reset point.
- d) Failsafe (ON/OFF).

Note that if a deadband entry is not specified, the default setting of 0.25% will be used.

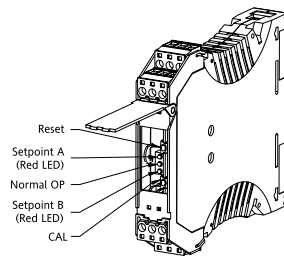

Function	S1								S2	
	1	2	3	4	5	6	7	8	1	4
Voltage Input										
250V	-	-	-	-	■	■	■	■	■	■
150V	-	-	-	-	■	■	■	■	■	■
50V	-	-	-	-	■	■	■	■	■	■
20V	-	-	-	-	■	■	■	■	■	■
5V	-	-	-	-	■	■	■	■	■	■
500mV	-	-	-	-	■	■	■	■	■	■
150mV	-	-	-	-	■	■	■	■	■	■
50mV	-	-	-	-	■	■	■	■	■	■
Current Input										
20mA	-	-	-	-	■	■	■	■	■	■
100mA	-	-	-	-	■	■	■	■	■	■
Remote Cal Enable	■	-	-	-	-	-	-	-	-	-
A Hi/Low (Hi)	-	■	-	-	-	-	-	-	-	-
B Hi/Low (Hi)	-	■	-	-	-	-	-	-	-	-
Failsafe	-	-	-	■	-	-	-	-	-	-

Key: ■ = 1 = ON or Closed; - = n/a

Figure 4: Switch Settings

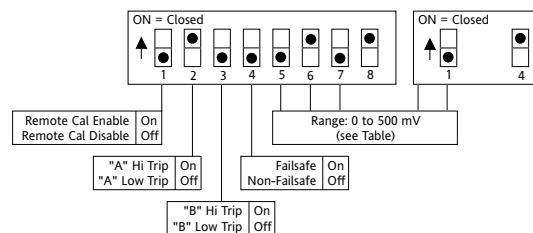

Default Switch Settings

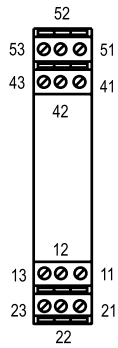

Pin	Description
11	N.O. Relay B
12	Com. Relay B
13	N.C. Relay B
21	DC Power (+)
22	DC Power (-)
23	No Connection
41	AC Input (Hot)
42	AC Input (Neutral)
43	No Connection
51	N.O. Relay A
52	Com. Relay A
53	N.C. Relay A

Figure 5: Wiring Connections

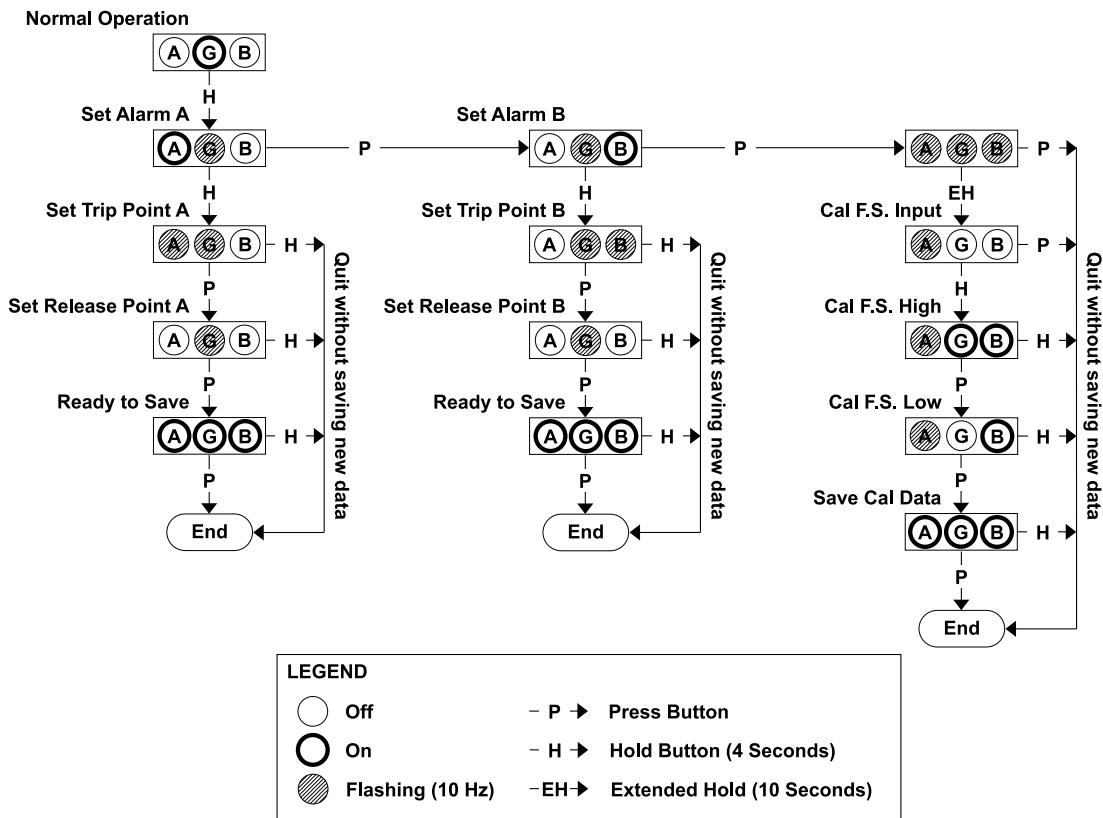

Figure 6: Calibration Flowchart

Specifications

Inputs:

Voltage Input Ranges:

50mV, 150mV, 500mV, 5V, 20V, 50V, 150V, 250V

Impedance: >100k Ohms

Overvoltage: 275VAC

Frequency Range: 40 to 400 Hz

Current Input Ranges:

20mA, 100mA

Impedance: 10 Ohms, typical

Overcurrent: 200mA, max

Overvoltage: 60V

Minimum Deadband:

Range	Deadband
50mV	0.2% (100uV)
150mV	0.2% (300uV)
500mV	0.2% (1mV)
5V	0.1% (5mV)
20V	0.1% (20mV)
50V	0.1% (50mV)
150V	0.1% (150mV)
250V	0.1% (250mV)
20mA	0.1% (20uA)
100mA	0.1% (100uA)

Response Time:

Dynamic Deadband:

Relay status will change when proper setpoint/process condition exists for 100mSec. or greater.

Normal Mode (analog filtering): <250mSec

Setpoint:

Effectivity: Setpoints are adjustable (by pushbutton) over 100% of the selected input span

Repeatability (constant temperature):

>200mV/10mA: 0.1% of full scale

<200mV/10mA: 0.2% of full scale

Relay Contacts:

2 SPDT (2 form C) Relays; 1 relay per setpoint

Current rating (resistive): 120VAC: 5A; 240VAC: 2A; 28VDC: 5A

Material: Gold flash over silver alloy

Electrical Life: 10⁵ operations

Reset Switch (WV168-2001 only):

For unlatching the relay once the process is no longer in the alarm state.

Local Range Selection: By DIP switch

Stability: ±100ppm of FS /°C

Common Mode Rejection: 120dB @ DC, >90dB @ 60Hz, or better

Isolation: 1800VDC

Power: 9 to 30VDC; 1.2W typ., (3.25W max both relays energized)

Host Module Interface: IR link

Size: DIN rail case – refer to Dimensions drawing

Environmental:

Operating Temperature: 0°C to +60°C (32 to 140°F)

Storage Temperature: -25°C to +85°C (-13 to 185°F)

Operating Humidity: 15% to 95%RH (non-condensing) at 45°C

Storage Humidity: 90%RH (non-condensing) at 60°C for 24 hrs

Agency Approvals (EMC & Safety):

CE: EN61326, EN61010-1

UL508 and CSA C22.2 No. 1010-1 Combined mark

RoHS compliant

Note that detailed installation instructions are available on our website.

Ordering Information

Specify:

1. Model:
WV168-2000 (non-latching) or
WV168-2001 (latching)
2. Optional Custom Factory Calibration (specify **C620**, see required settings under "Calibration, page 2).
3. Accessories.

Accessories

All WV Series modules will mount on standard TS35 (model MD03) DIN rail. In addition, the following accessories are available:

WVC16	Communications Interface
MD03	TS35 x 7.5 DIN Rail (2 meters)
WV905	24VDC Power Supply (0.5 Amp)
H910	24VDC Power Supply (1 Amp)
H915	24VDC Power Supply (2.3 Amp)
MB03	End Bracket for MD03
C650	Utility software for WVC16

Dimensions

Dimensions are in millimeters (inches)

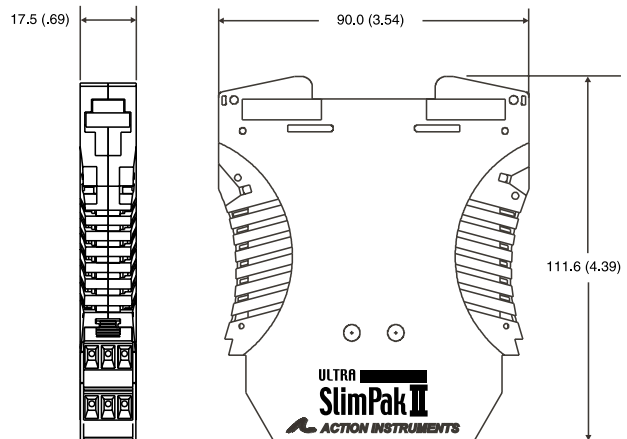

Eurotherm, Inc

741-F Miller Drive
Leesburg, VA 20175-8993
703-443-0000

info@eurotherm.com or www.eurotherm.com/actionio

Factory Assistance

For additional information on calibration, operation and installation contact our Technical Services Group:

703-669-1318

actionsupport@eurotherm.com

721-0865-00-C 09/06 Copyright© Eurotherm, Inc 2006

Action Instruments • Barber-Colman • Chessell • Continental • Eurotherm