

Q488-0001



# ACTIONI/Q<sup>®</sup> Q488

## DC Powered RTD, T/C, Ohm & mV Input Field Configurable Isolator

Provides an Isolated DC Output  
in Proportion to the Temperature Signal Input



- Instant Accuracy™
- Field Configurable Input Ranges
- PC or DIP Switch Configuration
- Eliminates Ground Loops

- TouchCAL Technology
- High Density DIN Rail Mounting
- Flexible DC Power Supply 9 to 30VDC
- SnapLoc™ Plug-in Terminals

### Description

The Q488 is a DC powered, DIN rail mount, RTD, thermocouple, mV or Ohm input signal conditioner with 1800V isolation between input, output and power. The field configurable input and output offers flexible, wide ranging capability for most temperature signal conditioning applications.

The Q488 is configured via DIP switch for the thermocouple type (B, C, E, J, K, N, R, S, T) or the RTD type (Pt, Ni & Cu). Additionally, functions such as signal linearization, up or down scale burnout, number of RTD leads (2, 3, 4) and voltage or current output are also set via dip switches (see Tables).

Configuration software, along with a serial port adapter cable is available for those who would prefer PC configuration capability. This Graphic User Interface (GUI) program takes the place of setting DIP switches and using the pushbutton for ranging. With this software, an input signal calibrator is not required for ranging since the values only need to be typed into the program and downloaded.

### Instant Accuracy™

Instant Accuracy™ maximizes accuracy and performance during warmup and during changes in ambient temperature. This patented cold-junction compensation technique utilizes two temperature sensors to measure the differential temperature near the terminal block. Using heat transfer calculations with the measured differential temperature and the known thermal conductivity of the PCB, the terminal junction temperature is determined with extreme accuracy. Even during unstable thermal states such as start-up, ambient temperature changes or changing load or power, the Q488 performs extremely accurate thermocouple temperature measurement.

Instant Accuracy improves system performance and productivity due to reduced warm up time, fewer temperature measurement errors and tighter process control for higher quality. Most significantly, it allows calibration to be checked quickly and accurately without the effects of rapid ambient temperature changes due to opening a control panel door, which often causes erroneous readings and miscalibrations; a common cause of measurement errors.

### TouchCAL™ Technology

TouchCAL™ technology allows easy field ranging for any of the thermocouple or RTD input types. For example, the dip switch configured range for the J type thermocouple is -210 to 760°C. Using a thermocouple simulator as a reference, the model Q486 could be ranged for 0 to 50°C or 0 to 500°C by simply applying the desired minimum and maximum input levels and pushing the range button to store the levels in non-volatile memory. The output is ranged by applying an input signal to achieve an accurate output level and pushing the range button.

### Applications

The model Q488 field configurable thermocouple or RTD input isolator is useful in eliminating ground loops and interfacing temperature sensors to data acquisition and control systems.

Three-way isolation completely eliminates ground loops from any source. Isolation protects expensive SCADA systems from ground faults and allows the noise reduction benefits of grounded thermocouples or sensors to be realized.

The Q488 employs the latest analog to digital signal processing technology and advanced low-power microprocessors. Instant Accuracy cold-junction-compensation (CJC) of thermocouples, and lead length compensation for RTDs ensures an extremely accurate and stable signal for virtually any temperature sensor to DC signal conversion.

High density DIN rail mounting offers a very compact solution and saves valuable panel space. Power is delivered to the Q488 using the exclusive I/QRail which reduces wiring requirements and the need to daisy-chain power. SnapLoc terminals ensure easy installation and low Mean-Time-To-Repair (MTTR).

### Diagnostic LEDs

The Q488 is equipped with front panel LEDs for input power (green-on), input overrange and underrange; input open circuit (yellow-on); and switch setting error (red-on).

## Configuration

The Q488 can be configured via DIP switches for a wide variety of temperature input ranges for RTD, thermocouple, ohm and millivolt sensors. Inputs can be offset by >90% or adjusted down to <10% of the full scale span.

Unless a specific customer range is ordered, the factory presets the Q488 as follows:

Input Type: Thermocouple, J-Type  
 Input Range: 0 to 500°C  
 Burnout: Up Scale  
 Output Range: 4/20mA

Refer to the tables for other I/O ranges.

1. With power off, snap off the faceplate by lifting the right edge away from the heatsink.
2. For RTD or Resistance inputs, set position 1 and 2 of SW2 for 2, 3 or 4 wire resistance input (see Table 1). For thermocouple inputs these switches ignored and can be in any position.
3. Configure the output for voltage or current using position 3 of SW2 (see Table 2).
4. If the input range desired is the full scale range for the input type (e.g. Pt100 Ohm = -200°C to 850°C), then set position 4 of SW2 to ON (or closed) for this default range (see Table 3). If configuration of a sub-range is preferred (e.g. Pt100 Ohm, 0 to 500°C), then set position 4 of SW2 to OFF (or open) to enable use of the ranging pushbutton adjustment.

5. If the output range desired is the full scale range for the output type (e.g. 4-20mA or 2-10V), then set position 5 of SW2 to ON for either of the full scale default output ranges (see Table 4). If configuration of a sub-range is preferred (e.g. 12-20mA or 1-5V), then set position 5 of SW2 to OFF (or open) to enable use of the ranging pushbutton adjustment.

6. Set Burnout detection with position 6 of SW2 (see Table 6). The ON position (up scale) will force the output beyond full scale when the t/c input is open circuit. The OFF position (down scale) will force the output below 0% when the input is open circuit.

7. Set the t/c Linearization function with position 7 of SW2 (see Table 7). The ON position will provide an output linear to the temperature input signal. The OFF position will provide an output directly proportional to the thermoelectric (mV) input (i.e. not linearized to temperature).

Note: The unit must be configured with linearization turned ON. Once the configuration is saved, linearization can then be turned OFF.

8. Set the Configuration Mode with position 8 of SW2 (see Table 8). The ON position is for DIP switch configuration. The OFF position is for configuring via PC using a serial interface cable (consult factory regarding cable and software).

9. Set the Input Type with position 1 and 2 of SW3 (see Table 5).

10. Set the specific RTD, thermocouple, millivolt or resistance input with position 3 through 6 of SW3 (see Table 9).

Note: For PC configuration refer to the software manual and help files associated with the model C681 accessort kit.

Table 1: RTD Type

RTD Type	SW2	
	1	2
3-Wire	■	■
4-Wire	■	
2-Wire		■

Key: ■ = 1 = On or Closed

Table 5: Input Type

Input Type	SW3	
	1	2
Thermocouple	■	■
RTD	■	
mV or Ohms		■

Key: ■ = 1 = On or Closed

Table 2: Output Type

Output	SW2
	3
Current	■
Voltage	

Key: ■ = 1 = On or Closed

Table 6: Burnout Detection

Burnout Detection	SW2
	6
Upscale	■
Downscale	

Key: ■ = 1 = On or Closed

Table 3: Input Range Type\*

Input Range	SW2
	4
Default	■
User Defined	

Key: ■ = 1 = On or Closed

Table 7: Output Linearization

Output Linear to Temperature	SW2
	7
On	■
Off	

Key: ■ = 1 = On or Closed

Table 4: Output Range Type\*

Output Range	SW2
	5
Default	■
User Defined	

Key: ■ = 1 = On or Closed

Table 8: Config Mode

Configuration Mode	SW2
	8
By DIP Switch	■
By PC	

Key: ■ = 1 = On or Closed

Table 9: Input Select

T/C Type	SW3				Input Range	Accuracy Range	Input (A/D) Accuracy
	3	4	5	6			
R	■	■	■	■	0 to +1760j C	+200 to +1760j C	+/-1.0j C
J	■		■	■	-210 to +760j C	-100 to +760j C	+/-0.25j C
S	■	■	■		0 to +1760j C	+400 to +1760j C	+/-1.0j C
B	■	■	■		0 to +1800j C	+400 to +1800j C	+/-2.0j C
T	■	■		■	-270 to +400j C	0 to +400j C	+/-0.25j C
K	■	■	■		-270 to +1370j C	-100 to +1370j C	+/-0.3j C
N	■			■	-270 to +1300j C	70 to +1300j C	+/-0.4j C
C	■				0 to +2320j C	0 to +2320j C	+/-0.5j C
E		■	■	■	-270 to +1000j C	-100 to +1000j C	+/-0.25j C

RTD Type	SW3				Input Range	Input (A/D) Accuracy
	3	4	5	6		
Cu-9.035	■	■	■	■	-40 to +260j C	+/-0.25j C
Ni-120 067	■		■	■	-80 to +320j C	+/-0.15j C
Pt-100 385	■	■	■		-200 to +850j C	+/-0.15j C
Pt-100 3911	■	■	■		-200 to +630j C	+/-0.15j C
Pt-100 392	■	■			-200 to +630j C	+/-0.15j C
Pt-200 385	■		■		-200 to +850j C	+/-0.20j C
Pt-200 392	■		■		-200 to +630j C	+/-0.20j C
Pt-500 385	■			■	-200 to +850j C	+/-0.20j C
Pt-500 3911		■	■	■	-200 to +630j C	+/-0.20j C
Pt-500 392		■	■		-200 to +630j C	+/-0.20j C
Pt-1000 385		■	■	■	-200 to +850j C	+/-0.20j C

mV & Ohm Type	SW3				Input Range	Accuracy Range	Input (A/D) Accuracy	Minimum Span
	3	4	5	6				
+/- 90mV	■	■	■	■	-90 to +90mV	-90 to +90mV	+/-12uV	3mV
+/- 900mV	■	■	■	■	-100 to 900mV	-100 to 900mV	+/-25uV	3mV
0 to 4000 Ohms	■	■	■	■	10 to 4000 Ohms	10 to 4000 Ohms	+/-1.0 Ohms	10 Ohms

Key: ■ = 1 = ON or Closed

Input to Output error at 25°C is less than or equal to the Input Accuracy, plus the Linearization Accuracy, plus the Output Accuracy (plus the CJC Error for T/C Inputs).

\*Default for Outputs is either 2-10V or 4-20mA. Default for Inputs is the "Input Range" specified in Table 9. Note that if the input or output is set for default, then the input or output calibration will be skipped in the pushbutton programming sequence.

## Calibration

The Q488 is a microprocessor based circuit with internal references that are factory calibrated to better than 0.000005V. For this reason the Q488 does not need field calibration, but it can be configured (ranged) in the field for virtually any temperature to DC I/O combination.

For best results ranging should be performed in the operating installation, allowing at least 30 minutes for thermal equilibrium of the system. If ranging on a test bench is preferred, then an output load equal to the input impedance of the device connected to the output is recommended, along with a 30 minute warm up period.

1. After configuring the unit, install the module onto a piece of DIN rail and the I/Q Rail mounting combination. See the I/Q Rail data sheet for details.

2. Connect the input to a calibrated thermocouple simulator or resistance source and the output to a voltage or current meter. Apply power and allow the system to reach thermal equilibrium (approx. 30 minutes).

3. Adjust the input signal to the desired maximum and observe that the green LED is on. Push the CAL button and hold it down for more than 5 seconds (until the yellow and red LEDs are on).

*Note: To quit the calibration mode and reset the unit, push the CAL button and hold for more than 5 seconds. Or, wait for more than five minutes and the unit will time-out and automatically reset to the previously stored calibration.*

4. Push the CAL button momentarily (the yellow and green LEDs will now be on).

5. Apply the maximum input signal level, then push the CAL button to store. The yellow LED will now be on.

6. Apply the minimum input signal level, then push the CAL button to store. The green and red LEDs will now be on.

7. Adjust the input signal while monitoring the output signal until the output is at the desired maximum level (e.g. 20.00mA), then push the CAL button to store (the red LED will be on).

8. Adjust the input signal while monitoring the output signal until the output is at the desired minimum level (e.g. 4.00mA), then push the CAL button to store (the yellow, green and red LEDs will be on).

9. To finish calibration, push the CAL button once again. The green LED will be on if the input is within the calibrated range.

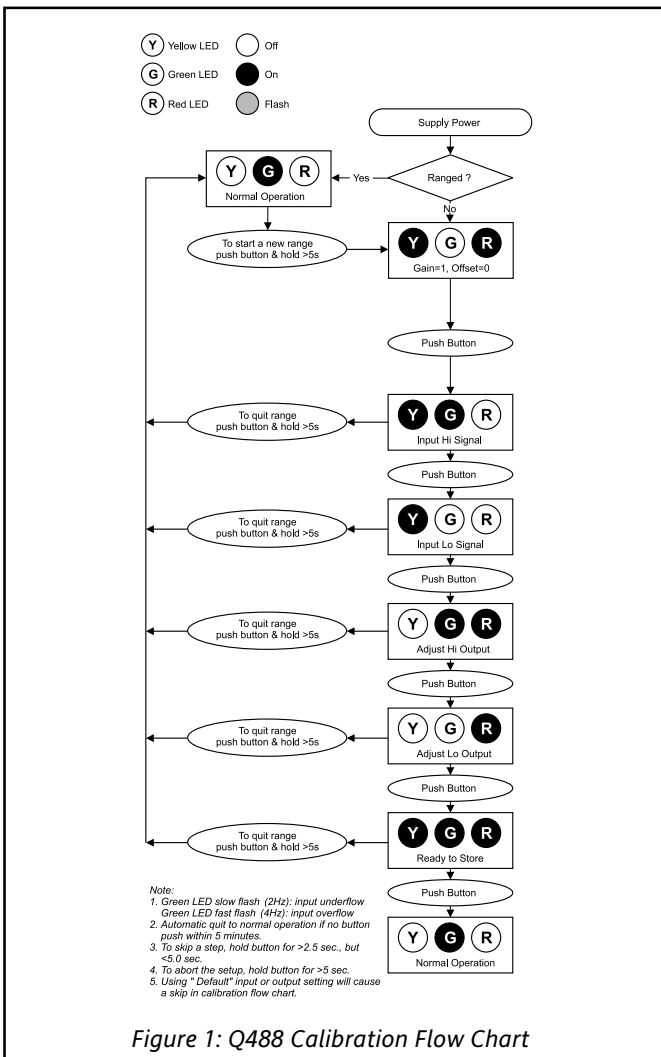

Figure 1: Q488 Calibration Flow Chart

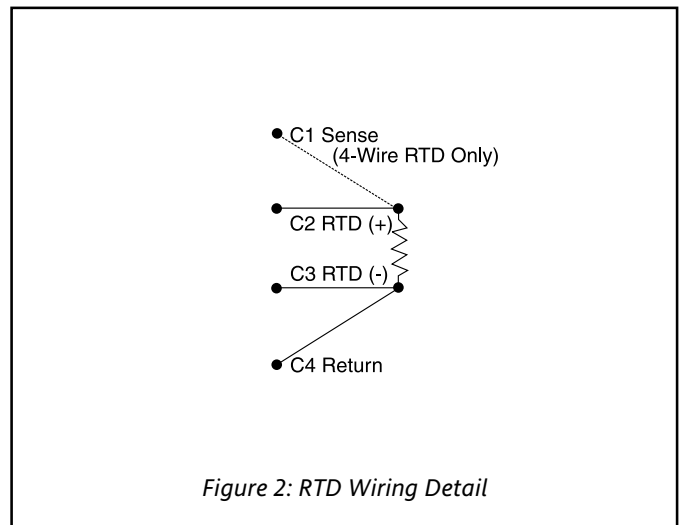

Figure 2: RTD Wiring Detail

Terminal	Connection	Terminal	Connection
A1	Current Output (+)	C3	RTD Input (-) or Resistance
A2	Voltage Output (+)	C4	RTD Return
A3	Output Common (-)	C5	T/C Input (-) or mV (-)
A4	Not Used	C6	T/C Input (+) or mV (+)
A5	DC Power (+)	P1	Not Used
A6	DC Power (-)	P2	Not Used
C1	RTD Sense	P3	DC Power (+)
C2	RTD Input (+) or Resistance	P4	DC Power (-)

**Specifications**

**Inputs:**

- Sensor Types: see Table 9
- Ranges: Any span within Range in Table 9
- Impedance:  $\geq 1.0M$  ohms typical for t/c and mV inputs
- RTD Excitation:  $\leq 0.3mA$
- Burnout Detection: up or down scale
- CJC Error:  $\leq \pm 0.1^{\circ}C$  max. (Instant Accuracy™ ensures the output is within  $\pm 0.5^{\circ}C$  of rated accuracy 30 seconds after powering

**Output:**

- Voltage
  - Ranges: 0-5V or 2-10V (default)
  - Drive: 10mA (1000 ohm load min.)
- Current
  - Ranges: 0-20mA or 4-20mA (default)
  - Drive: 15V (750 ohms max.)

**Isolation:**

1800VDC or peak AC between input output & power

**Configuration:**

- SW1: Pushbutton, input and output ranging
- SW2: Linearization, Burnout, Output (voltage or current), and initialization mode
- SW3: Input Type

**Accuracy:**

- Input (A/D): see Table 9
- Linearization:  $\leq \pm 0.05\%$  of accuracy range, max.
- Output:  $\leq \pm 10\mu A$  for current output  
 $\leq \pm 5mV$  for voltage output

**Thermal Stability:**

- CJC:  $\pm 0.01^{\circ}C / ^{\circ}C$  change in ambient, max.
- Zero:  $\pm 0.0075\%$  of full scale  $^{\circ}C$  change in ambient, max.
- Span:  $\pm 0.0075\%$  of full scale  $^{\circ}C$  change in ambient, max.
- Long Term:  $\pm 0.1\%$  max. over a 9 month period

**Response Time:**

400mSec, typical

**Turn On Time:**

$\leq 5$  seconds to establish output within 99% or  $0.5^{\circ}C$  of final value

**LED Indicator:**

- Power (green):
  - On when power is on
  - Flashes for t/c burnout flash
- Input (yellow):
  - Flashes for out of range
- (red):
  - Flashes for switch setting error
- Calibration: 1 green, 1 yellow and 1 red LEDs indicate steps in ranging process

**Common Mode Rejection:**

- 120dB at DC
- $> 90dB$  at 60Hz

**ESD Susceptibility:**

Capable of meeting IEC 801-2 level 3 (8kV)

**Humidity (non-condensing):**

- Operating: 15 to 95% @  $45^{\circ}C$
- Soak: 90% RH for 24 Hours @  $60^{\circ}C$

**Temperature:**

- Operating:  $-25^{\circ}C$  to  $+65^{\circ}C$  ( $-13$  to  $149^{\circ}F$ )
- Storage:  $-25^{\circ}C$  to  $+70^{\circ}C$  ( $-13$  to  $158^{\circ}F$ )

**Power:**

2.5W max., 9 to 30VDC  $\pm 10\%$

**Shipping Weight:**

0.5 lbs.

**Wire Terminal:**

Socketed screw terminals for 12-22AWG

**Agency Approvals**

- UL recognized per standard UL508 (File No. E99755).
- CE Compliance per EMC directive 89/336/EEC and Low Voltage 73/23/EEC.

**Ordering Information**

Models & Accessories

**Specify:**

1. Model: **Q488-0001**
2. Accessories: (see Accessories)
3. Optional Custom Factory Calibration; specify **C620** with desired input and output ranges.

**Accessories**

Action/Q series modules will mount on standard TS32 (model MD02) or TS35 (model MD03) DIN rail. In addition, the following accessories are available:

- C681-0001** PC Adapter & Configuration Software
- MD02** TS32 DIN rail
- MD03** TS35 x 7.5 DIN rail
- WV905** 24VDC Power Supply (0.5Amp)
- H910** 24VDC Power Supply (1Amp)
- H915** 24VDC Power Supply (2.3Amp)
- IQRL-D002** 2 Position I/QRail & DIN rail
- IQRL-D004** 4 Position I/QRail & DIN rail
- IQRL-D008** 8 Position I/QRail & DIN rail
- C620** Factory Calibration

**Dimensions**

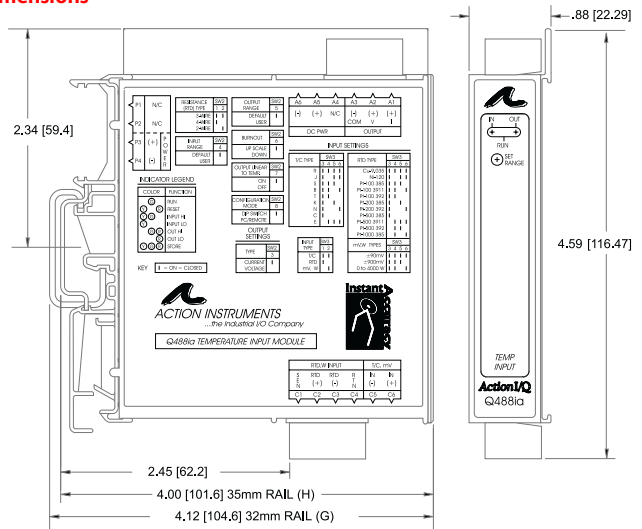

Invensys



Printed on recycled paper

**Factory Assistance**

For additional information on calibration, operation and installation contact our Technical Services Group:

**703-669-1318**

[actionsupport@eurotherm.com](mailto:actionsupport@eurotherm.com)

721-0708-00-L 2/09 Copyright© Eurotherm, Inc 2009

**Eurotherm, Inc**

741-F Miller Drive  
Leesburg, VA 20175-8993  
703-443-0000

[info@eurotherm.com](mailto:info@eurotherm.com) or [www.eurotherm.com/actionio](http://www.eurotherm.com/actionio)

**Action Instruments • Barber-Colman • Chessell • Continental • Eurotherm**