

Think Automation and beyond...



# SafetyOne

## FS1A Safety Controller



IDEC CORPORATION

(09/01/07)

## Complies with key safety standards



In Human Machine Interface (HMI) environment, ensuring the safety of operators and machines is given the top priority. Enabling switches, emergency stop switches, light curtains, and other safety products are used to provide safety, and the **SafetyOne** can monitor and evaluate the safety information from the safety products most effectively.

The **SafetyOne** satisfies the highest requirements of key safety standards, such as category 4 of EN 954-1, SIL3 of IEC 61508, and performance level e of EN ISO 13849-1. The new safety controller of innovative concept helps you implement applications without requiring any programming. All you need is to select one of the eight logic functions; operation starts simply by connecting safety inputs and output equipment.

### The **SafetyOne** satisfies:

EN954-1:	Category 4
IEC 61508:	SIL3
ISO 13849-1:	Performance level e

### The **SafetyOne** complies with:

ISO	IEC	EN	ANSI/RIA	ANSI	SEMI	NFPA
-----	-----	----	----------	------	------	------

## Reduces overall cost

### Replaces safety modules—simpler and easier wiring

One **SafetyOne** module can replace more than five safety relay modules (when configuring a partial or entire stop—Logic 7), reducing cost, wiring, and checking.

#### When using safety relay modules:

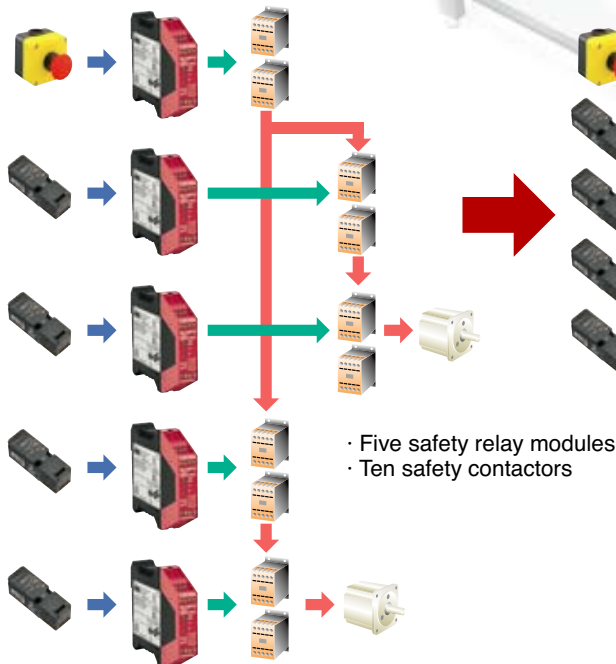

#### When using the **SafetyOne**:

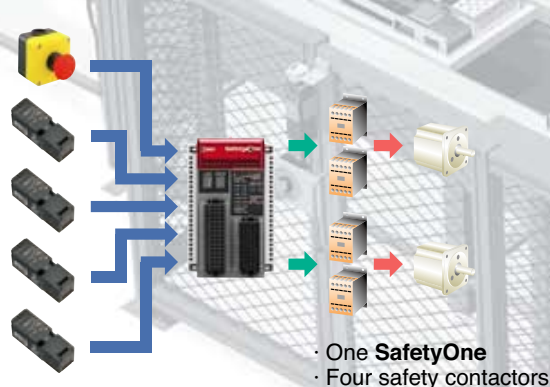

### Replaces programmable safety PLC and safety controller—simpler and easier configuring

Safety PLC or Safety Controller



Software (programs, function blocks)

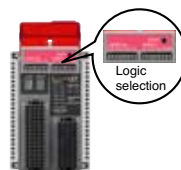
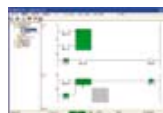

- Safety PLC
- Tools required for programming
- Creating and debugging a program
- Third-party certification for the program (time and cost)

- Simple design requiring DIP switch selection only
- No tools required
- No programming and debugging required
- No program certification required

(09/01/07)

# The Next Generation Safety Controller (FS1A)

Easy-to-set safety controller **SafetyOne** requires no programming to configure safety circuits, and meets the highest requirements of key safety standards.

## Downsizing

Various functions are packed within a compact safety controller.

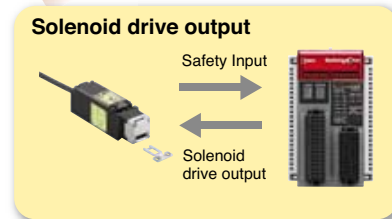
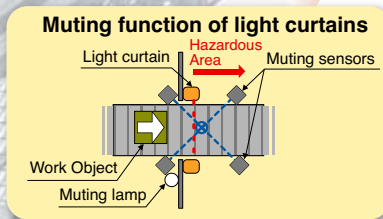
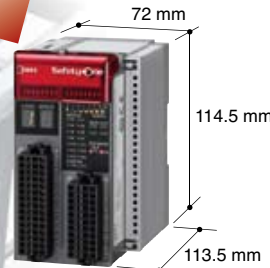
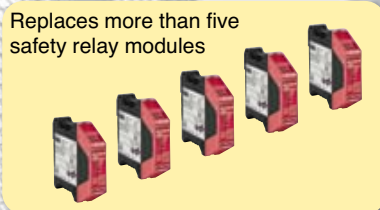
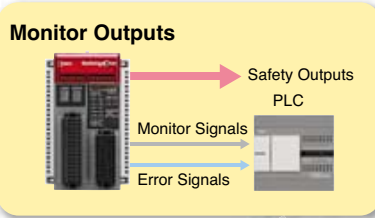

## Direct connection to various IDEC safety components

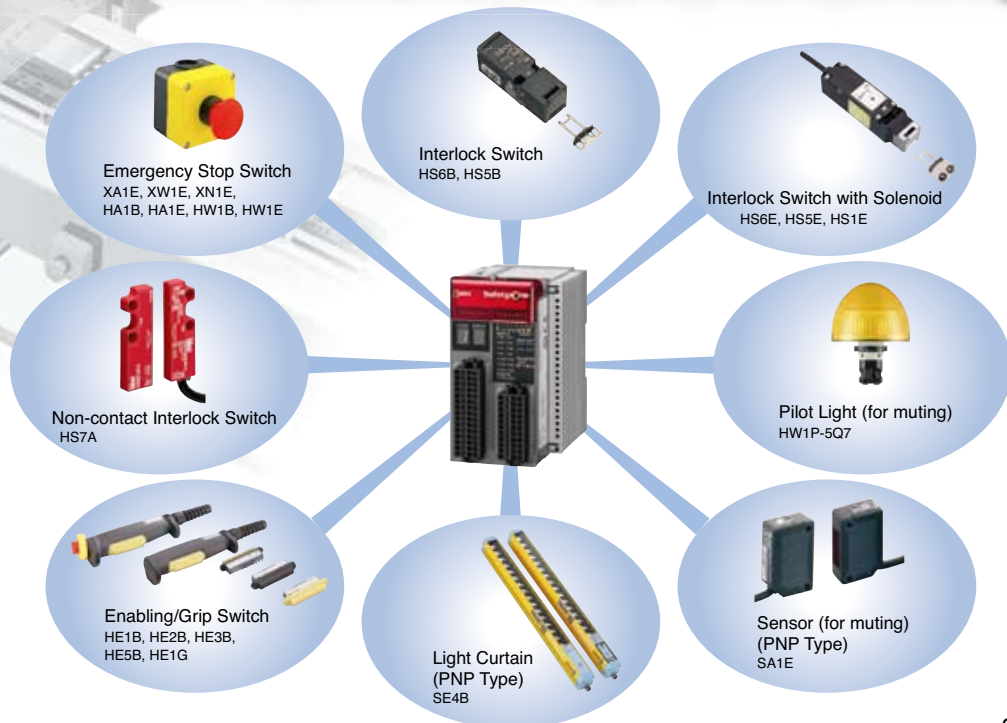



# The Next Generation Safety Controller

## Makes safety circuit configuration easier.

**IDEC offers**

Easy circuit configuration by **logic selection**—no programming

World's first logic-selecting configuration.  
Eight safety circuit logics are provided.

The best solution when the system has multiple points requiring complex I/Os, but the use of programmable controller is not desired.

Ladder or function block programming is not necessary.

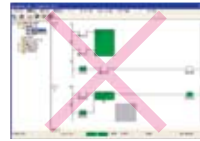

- Programming method has to be learned
- Debugging takes time
- Application software is needed

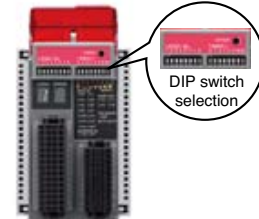

- Reduces setting
- Easy checking

**IDEC offers**

High performance—**partial stop/entire stop**

No programming required. Partial Stop—Entire stop is achieved by selecting a logic circuit. All you need is to wire the **SafetyOne** in the same manner as safety relay modules.

The best solution when configuring a system without using a safety relay module, or a safety PLC.

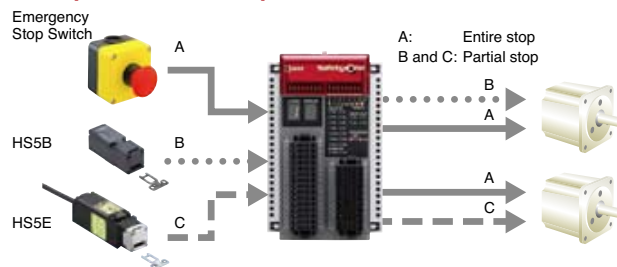

**IDEC offers**

Various safety inputs—**mechanical contacts and electric components**

The **SafetyOne** can be connected to a variety of inputs such as emergency stop switches and light curtains.

The best solution to eliminate the use of safety relay modules for each component.

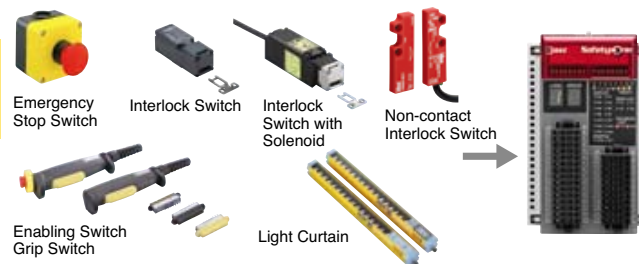

**IDEC offers**

Safety circuit monitoring—**circuit diagnosis with monitor outputs**

Outputs safety I/O status and **SafetyOne** errors.

The best solution for the control side to monitor which doors are open, and to see the error status of safety circuits.

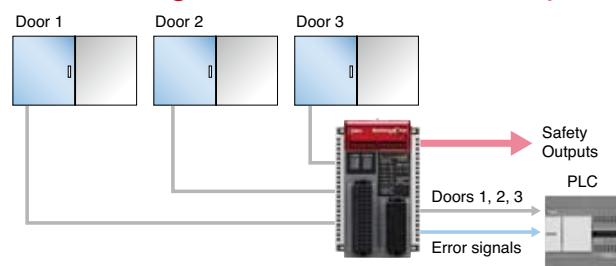

**IDEC offers**

Easy connection to interlock switches—**solenoid drive output**  
(Spring lock type)

Solenoid drive output reduces the required I/O points of a PLC.

The best solution to replace conventional PLCs to control interlock switches.

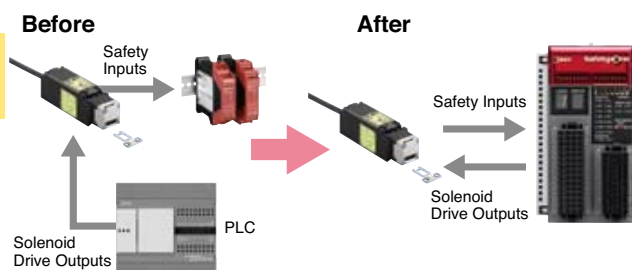

## Compliant with international safety standards



Applicable Standards	
ISO	13849-1, 10218-1
IEC	61508, 62061, 61496-1, 60204-1, 61131-2, 61000-6-2, 61000-6-4
EN	954-1, 13849-1, 62061, 61496-1, 60204-1, 61131-2, 61000-6-2, 61000-6-4
ANSI/RIA	R15.06
UL	508, CSA C22.2 No. 142
ANSI	B11.19
SEMI	S2
NFPA	79

The **SafetyOne** satisfies the requirements of SIL3 (IEC 61508), performance level e (ISO 13849-1), and safety category 4 (EN 954-1).

## Muting function

Muting function for a light curtain is provided. Just connect the muting sensor input and the light curtain input to the **SafetyOne**. Relay box and terminals are not necessary. Muting lamp output can also be connected.

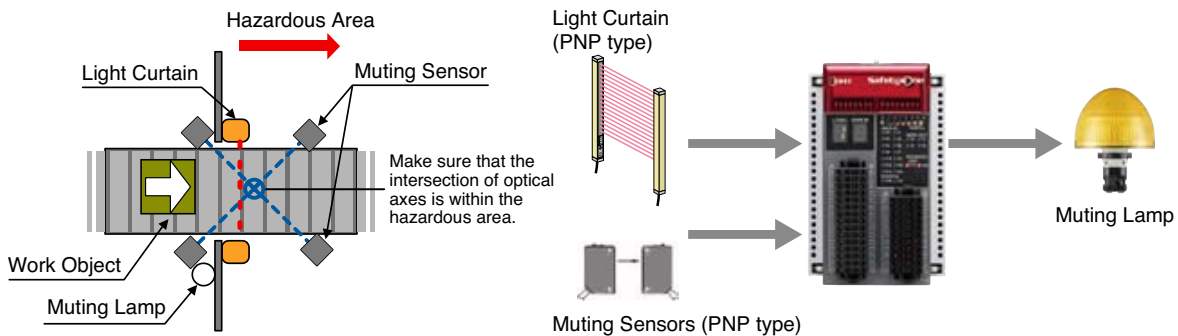

Note: When installing light curtains and muting sensors, ensure safety by referring to IEC TS 62046 technical documents.

## Multiple I/Os

- 14 safety inputs (6 for dual inputs)
- 4 safety outputs (2 for dual outputs)
- 2 start inputs
- 10 monitor outputs
- 2 solenoid/muting lamp outputs

## Connector wiring

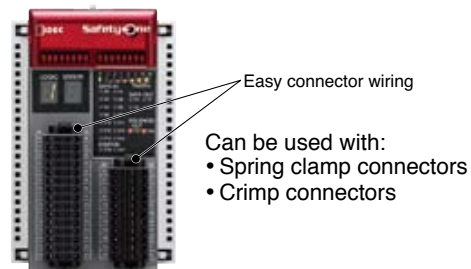

## Easy-to-read LED indicators



Errors and I/O statuses can be read easily with digital and LED indicators.

## Off-delay outputs available

8-level selections within 0 to 30 sec.

## Easy circuit configuration by logic switches

A safety circuit for emergency stop switches and interlock switches.

### Logic 1

General-purpose logic for various apparatus

Page 7

A safety circuit for interlock switches, non-contact interlock switches, and emergency stop switches.

### Logic 2

General-purpose logic for NO/NC contact inputs

Page 8

A safety circuit for safety solid state output components such as light curtains, emergency stop switches, interlock switches, and laser scanners.

### Logic 3

General-purpose logic for apparatus with openings

Page 9

A safety circuit for light curtains and muting function.

### Logic 4

Muting function logic for apparatus with openings

Page 10

A safety circuit for two contacts with a long time lag.

### Logic 5

General-purpose logic for devices for which sync time between contacts cannot be specified

Page 11

A safety circuit for mode selection of enabling switches, emergency stop switches, and interlock switches.

### Logic 6

The logic applicable for selection of active safety input devices

Page 12, 13

A safety circuit for partial stop (interlock switches) and entire stop (emergency stop switches).

### Logic 7

Partial stop 1 logic for various apparatus

Page 14, 15

A safety circuit for partial stop (interlock switch A) and entire stop (emergency stop switch or interlock switch B)

### Logic 8

Partial stop 2 logic for various apparatus

Page 16

## Logic 1

### Direct Opening

#### General-purpose logic for various apparatus

Logic 1 is used for safeguarding measures of machine tools and robots. It can be used with dual direct-opening components such as emergency stop switches and interlock switches. In this logic, when a safety component is operated, the **SafetyOne** shuts down the safety output immediately.

Machine tool



Robot

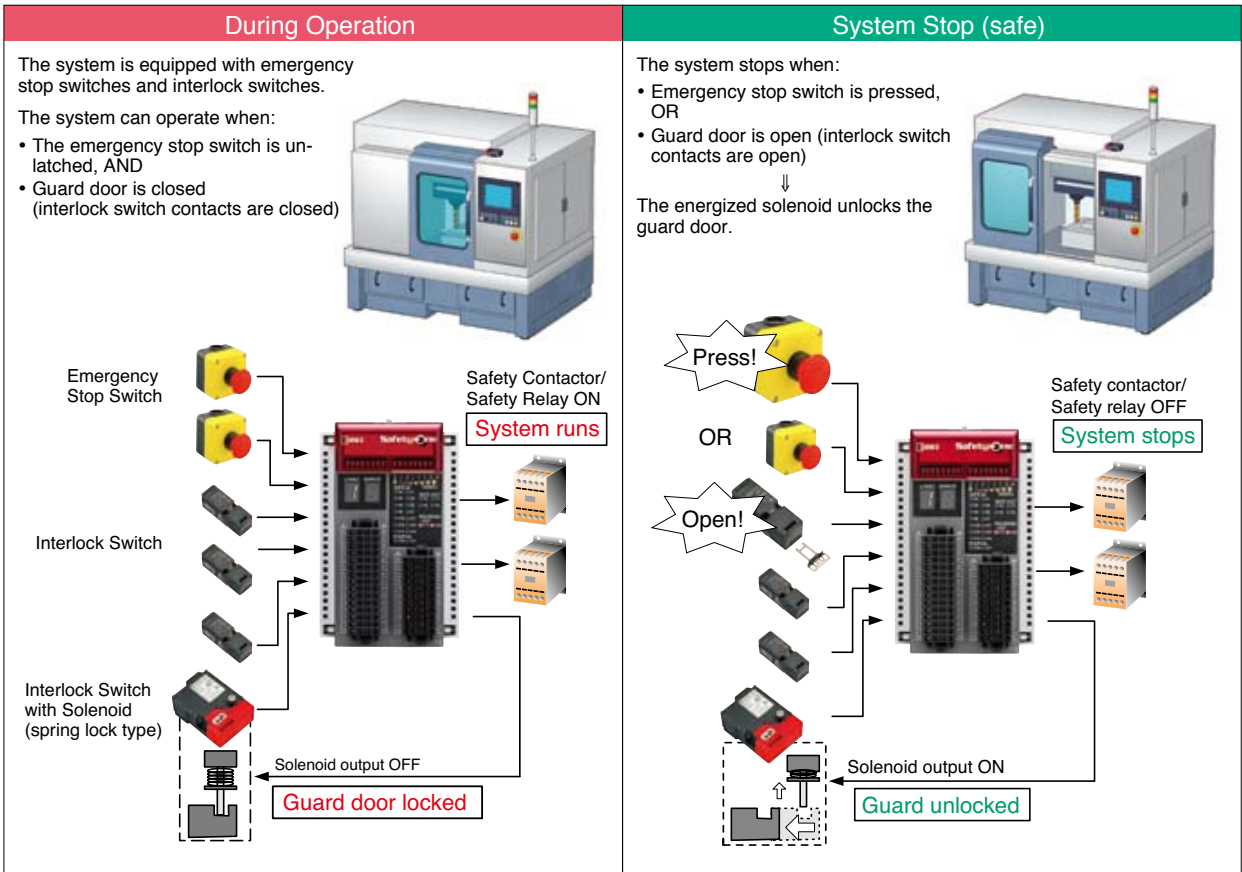

**• Input monitor error detection function**  
All logics have 0.5-sec input monitor error time on the dual channel direct opening inputs. For details, see user's manual.

**• Solenoid output function (muting lamp output function)**  
The **SafetyOne** has a solenoid control output. When operating on Logic 4, solenoid control output functions as a muting lamp output. For details, see user's manual.

**Note: Use spring-lock type interlock switch with solenoid. Solenoid lock type cannot be used.**

## Logic 2

### Normally Open and Normally Closed

### General-purpose logic for NO/NC contact inputs

Logic 2 is used for semiconductor manufacturing systems or food packaging systems which have non-contact interlock switches of NO/NC contacts. In this logic, components with dual NO/NC contacts such as a non-contact interlock switch and a mechanical interlock switch, as well as dual direct-opening components such as emergency stop switch and interlock switches can be used at the same time. When a safety component is operated, the **SafetyOne** shuts down the safety output

**Semiconductor Manufacturing System**



**Food Packaging System**

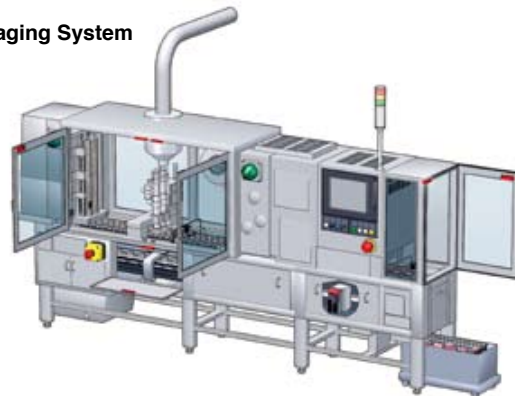

#### During Operation

The system is equipped with non-contact interlock switches, emergency stop switches, and an interlock switch.

The system can operate when:

- Emergency stop switch is unlatched, AND
- Guard doors are closed

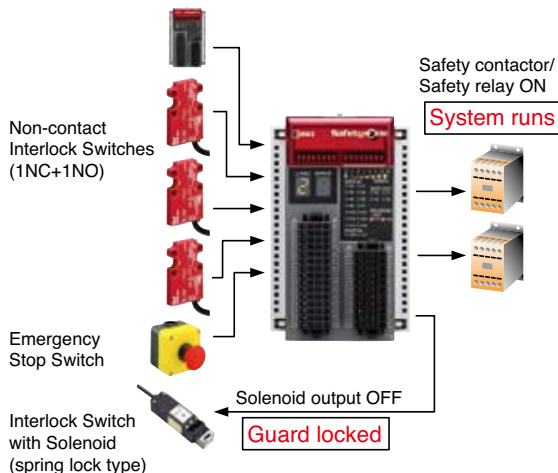

#### System Stop (safe)

The system stops when:

- Emergency stop switch is pressed, OR
- Guard door is open

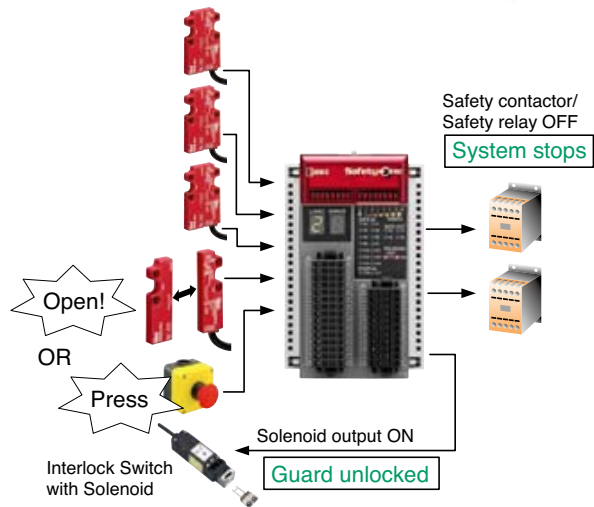

#### • Monitor output function

In addition to safe solid state output, the **SafetyOne** is equipped with a monitor output which sends internal error information. For details, see user's manual.

#### • Auto manual start and control start

Each logic has the option of setting one of two start inputs. Choose one that conforms to the system risk assessment.

- Auto manual start to detect input level
- Control start to detect the input's ON to OFF transition and the time

**Note 1: Use spring-lock type interlock switch with solenoid. Solenoid-lock type cannot be used.**

**Note 2: For details about non-contact interlock switches, see user's manual.**



## Logic 3

### Solid State

## General-purpose logic for apparatus with openings

Logic 3 is a general-purpose logic for robots and conveyor lines which have dual solid state outputs of light curtains and safety laser scanners. In addition, dual direct-opening components such as emergency stop switches and interlock switches can be used at the same time.

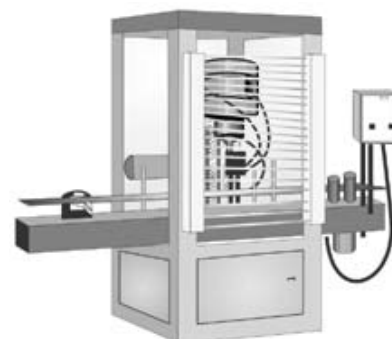
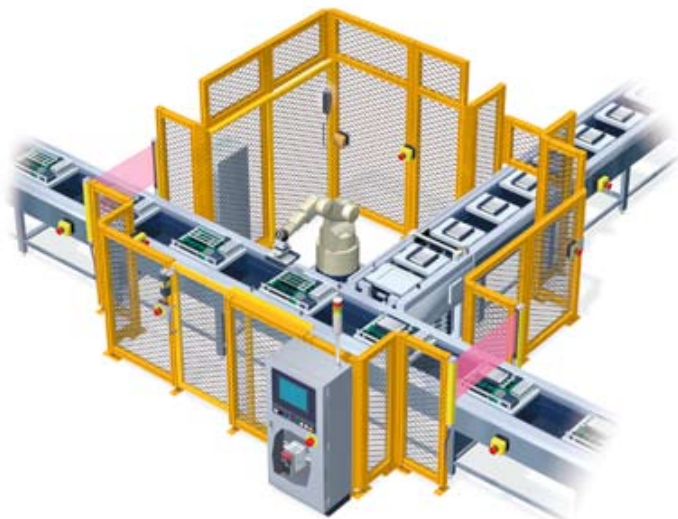

### Light Curtain for High Level of Safety

Productivity of conveyor lines and process machines can be improved by installing the light curtains (IEC 61496). Safety can be ensured without the need for installing guard doors.

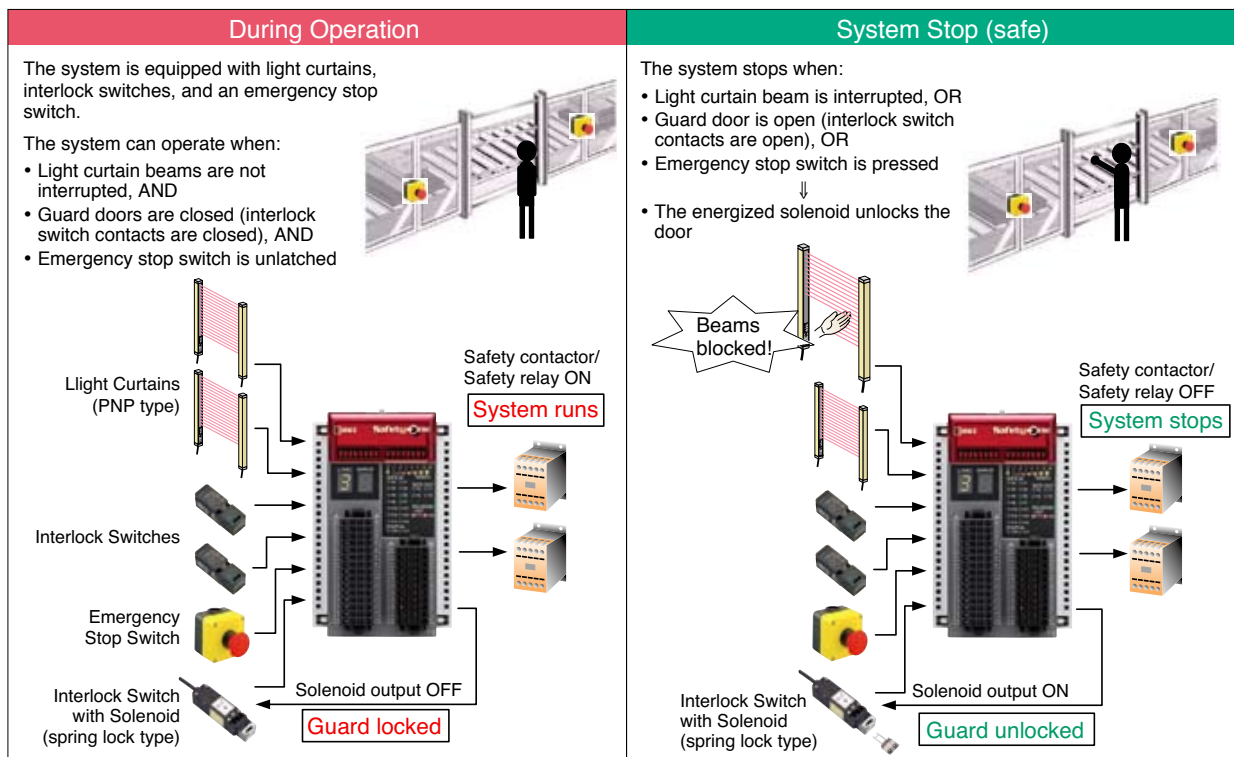

**Note 1: Use spring-lock type interlock switch with solenoid. Solenoid-lock type cannot be used.**

**Note 2: Use light curtain with a PNP output.**

## Logic 4

### Solid State with Muting

## Muting function logic for apparatus with openings

In Logic 4, muting functions are added to the dual solid state output of Logic 3.

Dual direct-opening components such as emergency stop switches and interlock switches can be used at the same time.

#### Muting Function Improves Productivity

With a muting function, the system stops when detecting a human and temporarily defeats the light curtain while work objects are being supplied. This improves the system's productivity. Muting functions can be used easily by connecting the light curtain, muting sensor, and muting lamp to the **SafetyOne** (Note). In muting status, the OFF signals of corresponding safety solid state outputs are defeated.

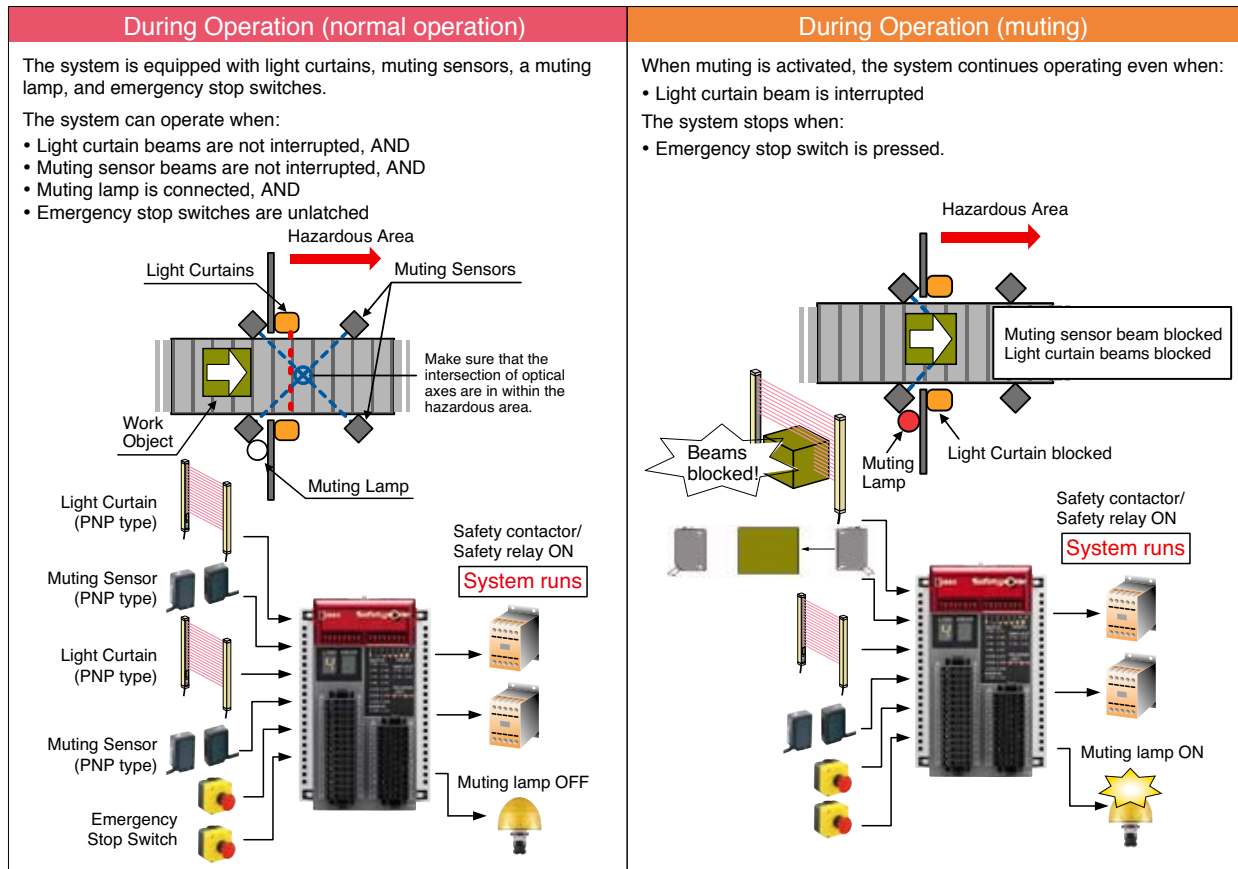

**Note 1:** Use light curtain with a PNP output. **Note 2:** Use muting sensor with 3-wire PNP output.

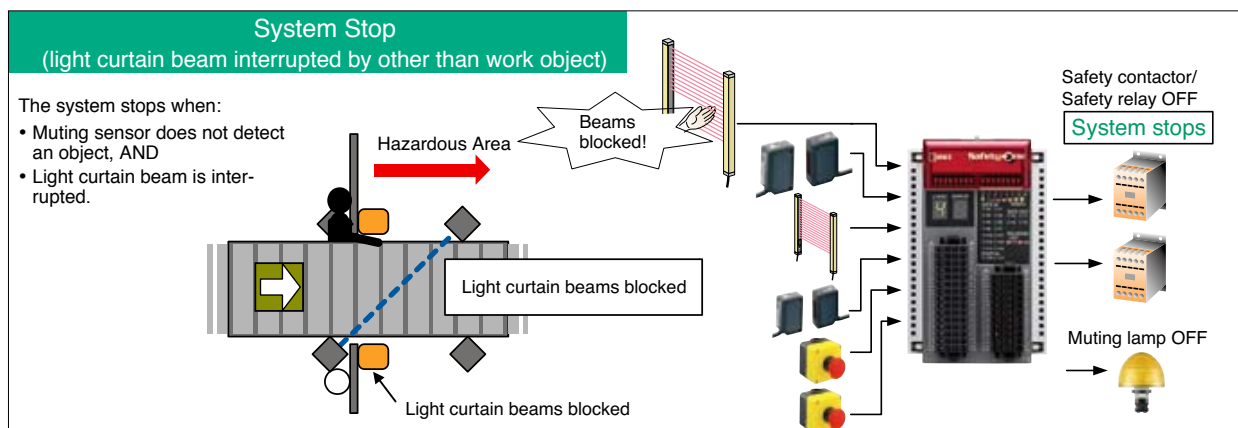

Note: Use light curtains, muting sensors, and muting lamps which meet the safety regulations or safety category of the country or regions where the products are used. Otherwise safety cannot be ensured, resulting in possible danger.

## Logic 5

### Dependant

### General-purpose logic for devices for which sync time between contacts cannot be specified

Logic 5 is used for providing safeguarding measures of various systems such as machine tools and robots. Because the input error detection time of dual inputs (dual interlock inputs) are set to  $\infty$  (infinite), this logic can be used even when there is a long time lag between the two inputs. When a safety component is operated, the **SafetyOne** shuts down the safety output immediately.

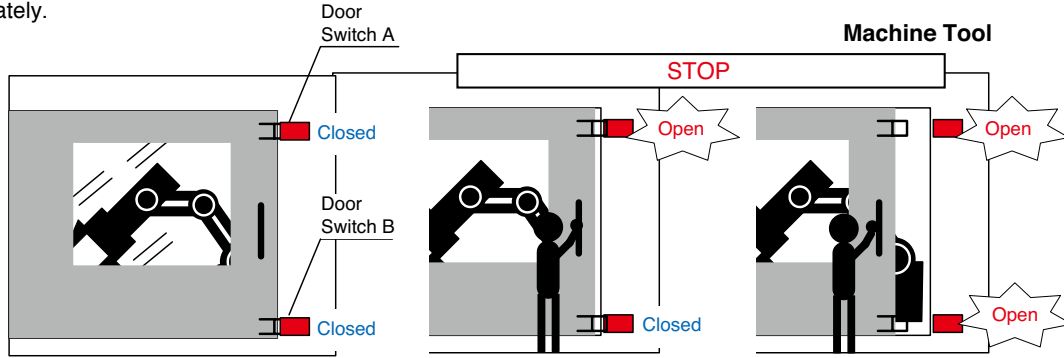

#### Logic 1

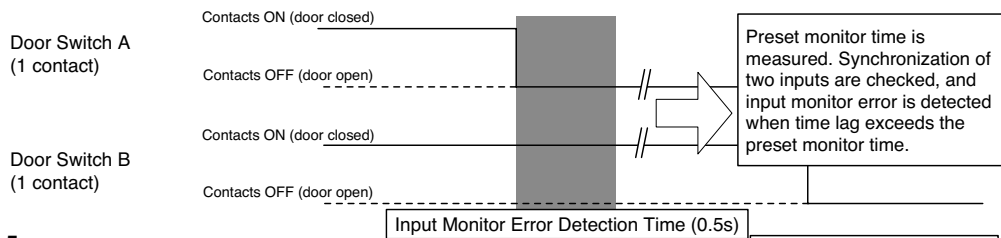

#### Logic 5

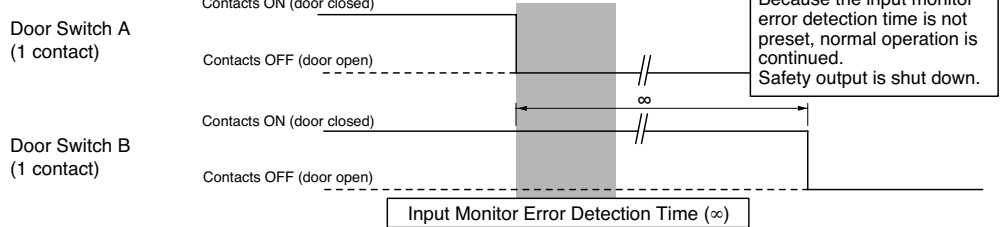

Logic 1 is used when the operations of two contacts (such as of emergency stop switch) occur almost at the same or the time lag can be specified. Higher safety is achieved by specifying the input monitor error detection time. Logic 1, however, cannot be used in applications where the time lag cannot be specified, such as when interlock switches are installed on a guard door. Logic 5 has an infinite monitoring time, therefore it can be used regardless of the location of the interlock switch and the speed to open the guard door.

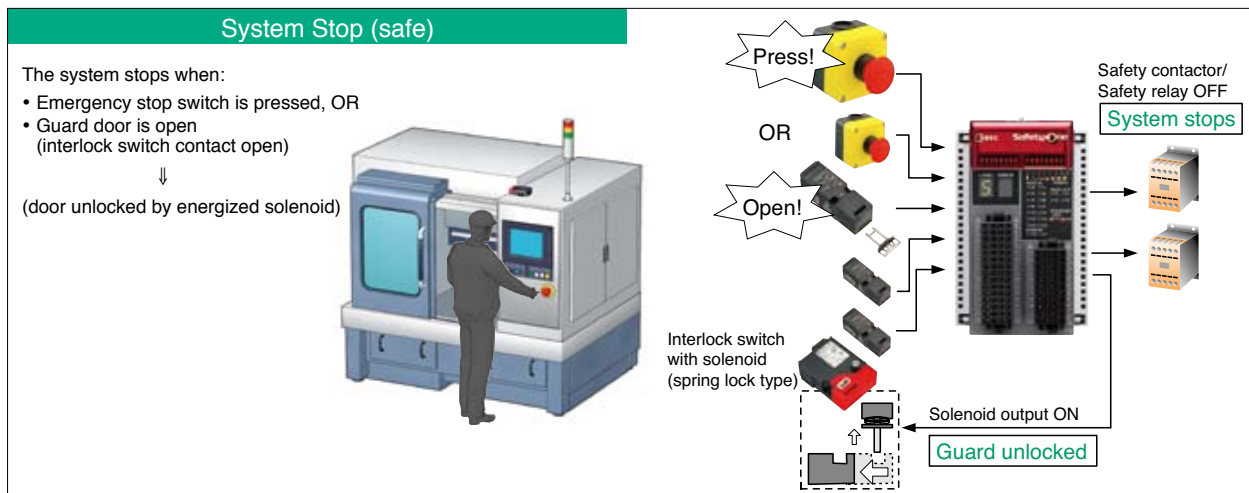

**Note: Use spring-lock type interlock switch with solenoid. Solenoid-lock type cannot be used.**

## Logic 6

### Mode Selection

The logic applicable for selection of active safety input devices

Logic 6 is the mode selection logic used in machine tools, semiconductor manufacturing equipment, and other systems where an active safety component is switched depending on the operation mode. Of dual direct-opening input and dual interlock input, an active input can be selected using the mode selection switch.



#### Mode Selection Ensures Safety

When the operator works inside a guard door for teaching, checking, and maintenance, an active safety component needs to be switched from interlock component, such as interlock switch installed on the guard door, or an enabling switch of a grip switch and teaching pendant.

#### Enabling Switch Ensures Safety

An enabling switch enables the manual operation of machines and robots only when the switch is maintained in the pre-determined position (position 2). When the operator either releases (position 1) or holds tightly (position 3) the switch, the circuit is shut down. While an emergency stop switch is used to stop a machine's operation by the operator's intention, an enabling switch is used to disable machine operation by the operator's reaction (releasing or holding tightly) to unexpected machine operation.



# FS1A Safety Controller

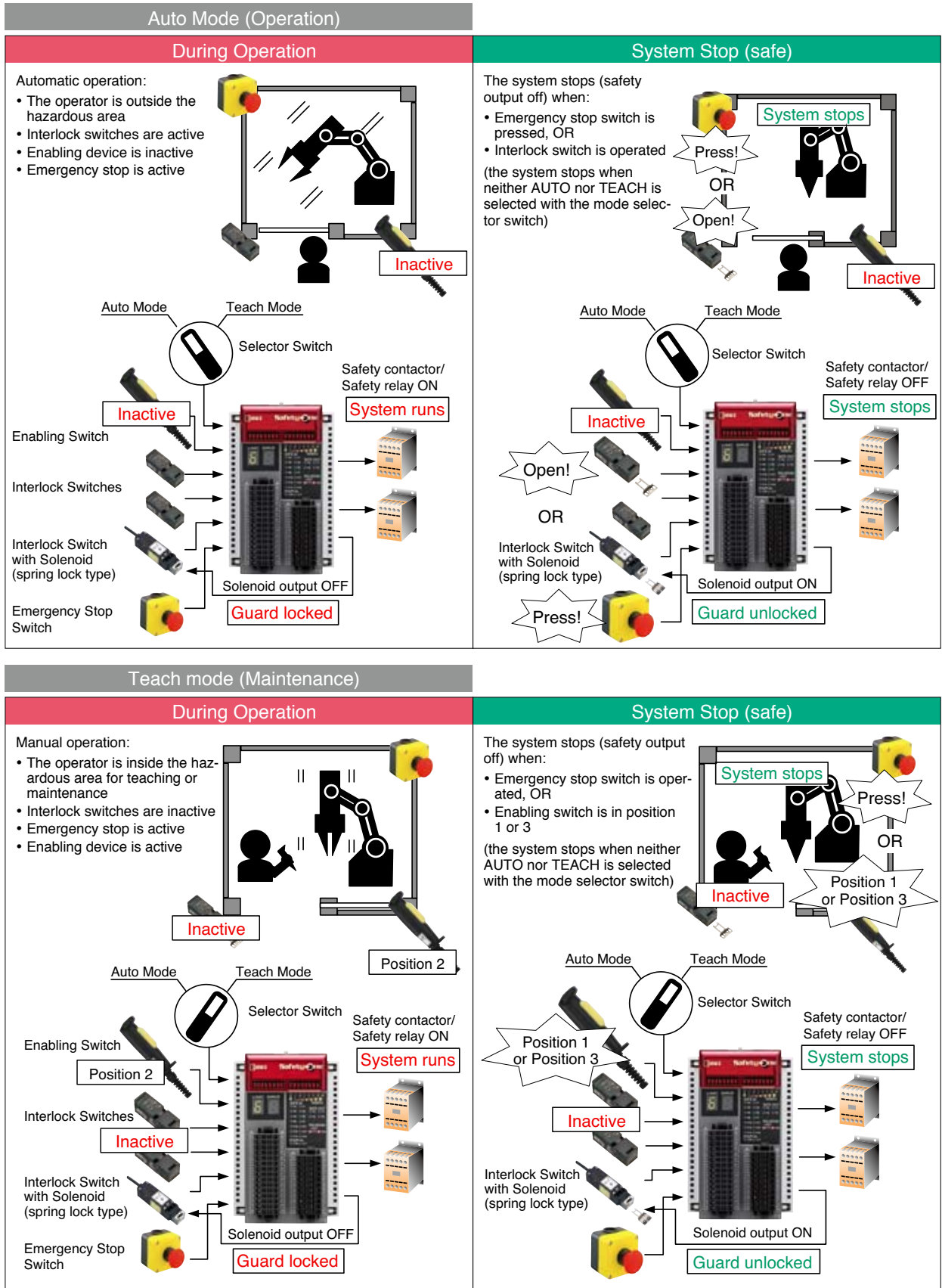

**Note: Use spring-lock type interlock switch with solenoid. Solenoid-lock type cannot be used.**

## Logic 7

### Partial Stop 1

#### Partial stop 1 logic for various apparatus

Logic 7 is used for partial stop of systems such as machine tools, semiconductor manufacturing equipment, and food packaging machines. Four safety outputs can be controlled in two lines.

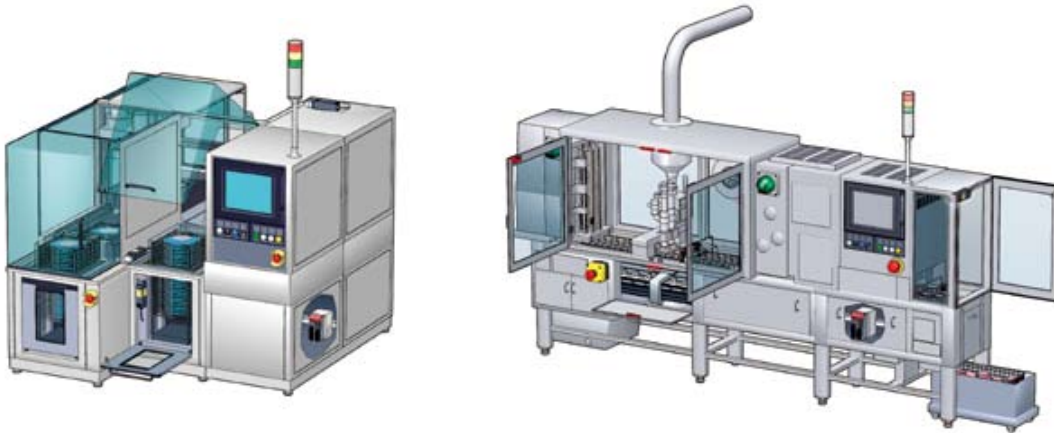

#### Partial Stop Improves Productivity

Two-line outputs can be controlled separately for partial stop, improving production efficiency greatly compared to entire stop.

#### During Operation

The system is equipped with an emergency stop switch and interlock switches. The system is configured so that pressing the emergency stop switch shuts down the entire system, while opening a door (equipped with an interlock switch) shuts down only the corresponding partial system. The other partial system keeps operating.

The entire system can operate when:

- The emergency stop switch is unlatched, AND
- The guards are closed (interlock switch contacts are closed)

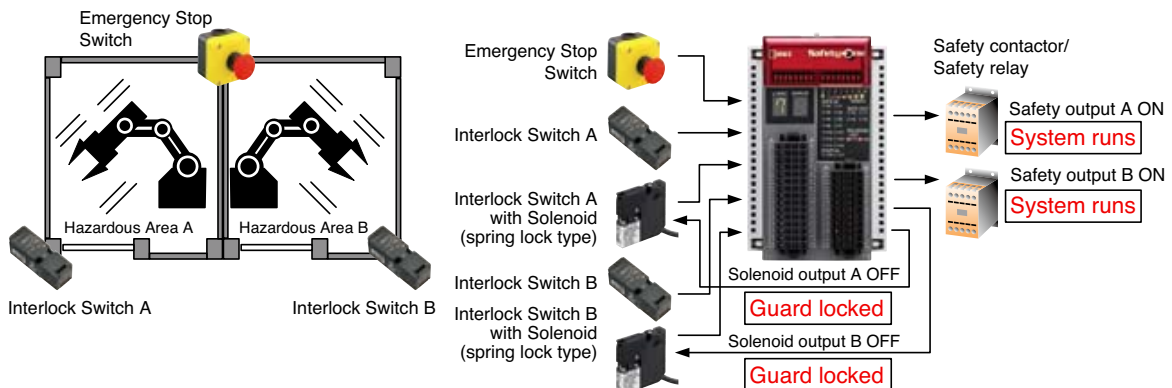

**Note: Use spring-lock type interlock switch with solenoid. Solenoid-lock type cannot be used.**

# FS1A Safety Controller

## Partial System Stop (Hazardous Area A)

The contacts of interlock switch A open, and safety output A turns off.

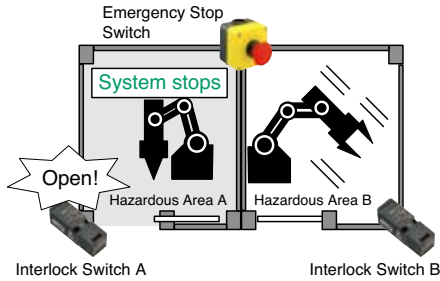

Guard door A is open

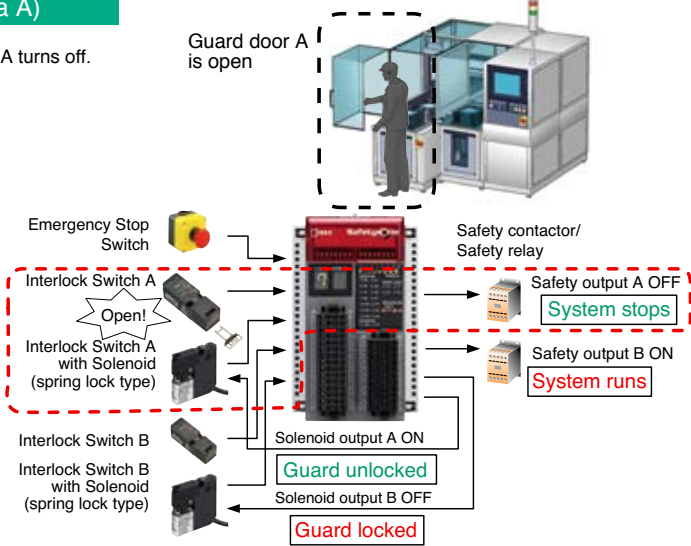

## Partial System Stop (Hazardous Area B)

The contacts of interlock switch B open, and safety output B turns off.

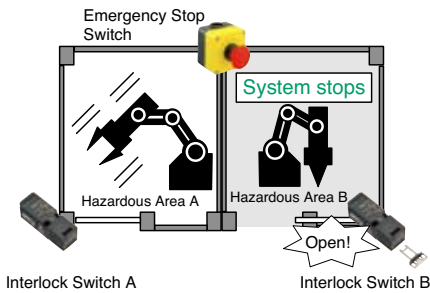

Guard door B is open

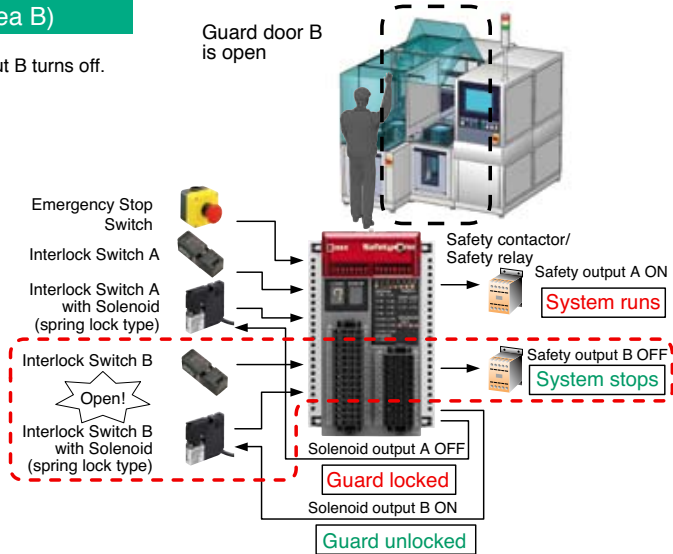

## Entire System Stop (Hazardous Areas A, B)

When the emergency stop switch is pressed, the entire system stops.

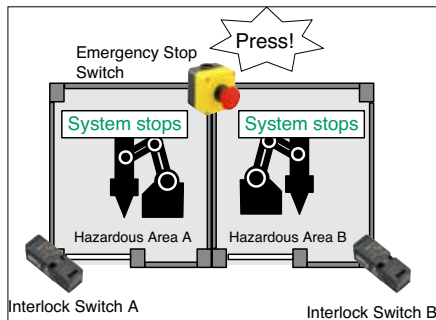

Emergency stop switch is pressed

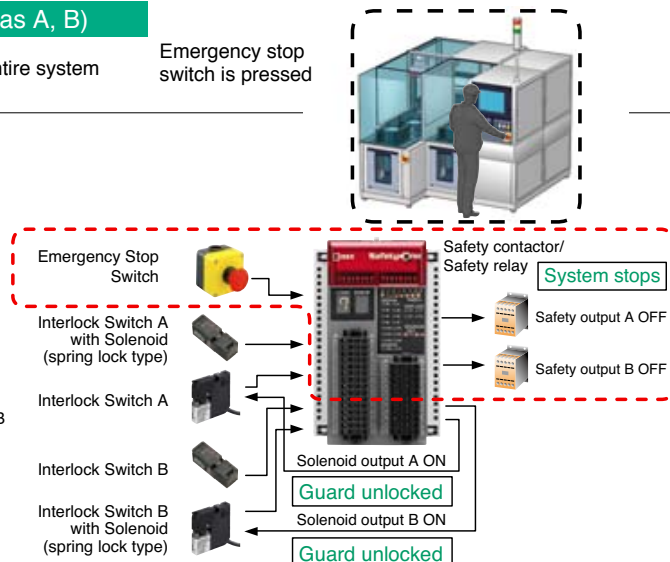

**Note: Use spring-lock type interlock switch with solenoid. Solenoid-lock type cannot be used.**

## Logic 8

### Partial Stop 2

### Partial stop 2 logic for various apparatus

Logic 8 is used for interlocked partial stop of systems such as machine tools, semiconductor manufacturing equipment, and food packaging machines. Four safety outputs can be controlled in two lines.

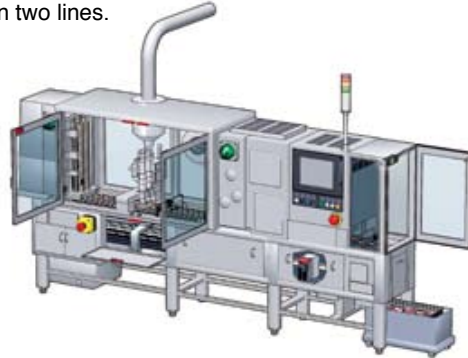

#### Partial System Stop (Hazardous Area B)

The contacts of interlock switch B open, and safety output B turns off.

Guard door B is open

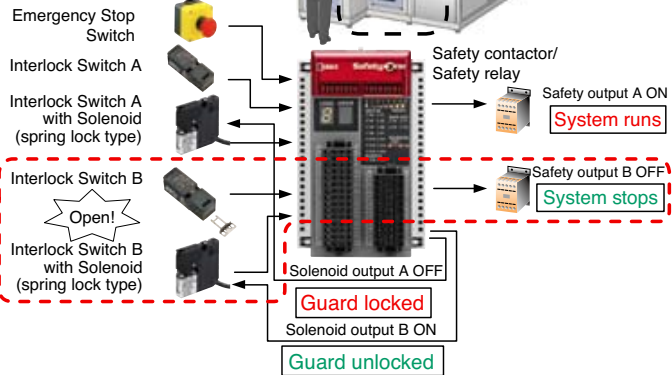
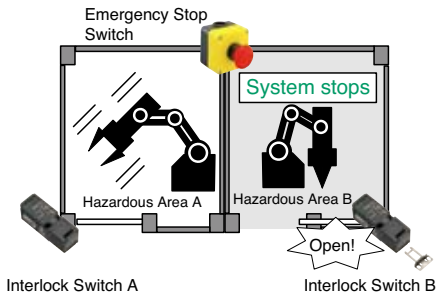

#### Entire System Stop (Hazardous Areas A, B)

Pressing the emergency stop switch or opening the guard A stops the entire system (hazardous areas A and B).

Emergency stop switch is pressed, or guard door A is open

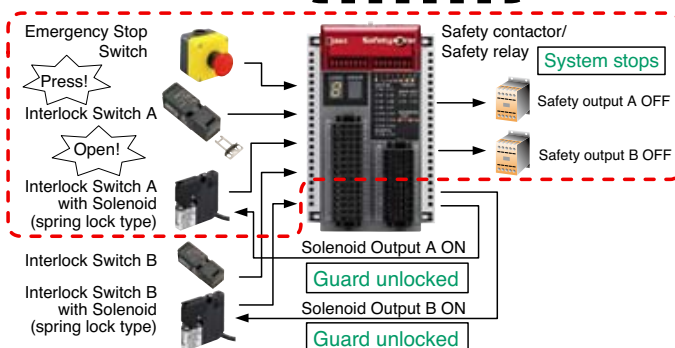
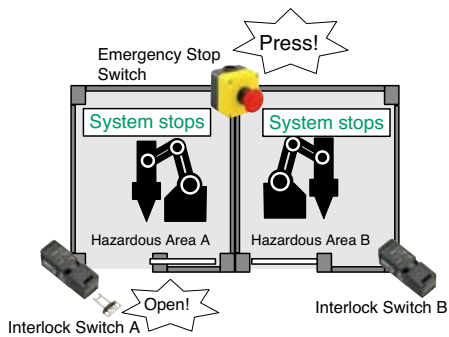

**Note: Use spring-lock type interlock switch with solenoid. Solenoid-lock type cannot be used.**



# SafetyOne FS1A Safety Controller

No programming required. Configuration completes by turning on a logic switch only.

- A safety circuit can be configured easily just by selecting a logic from eight pre-programmed logics.
- Partial/entire stop can be achieved just by selecting a logic.
- One SafetyOne module can connect with various inputs such as emergency stop switches and light curtains.
- The status of safety I/Os and the SafetyOne errors can be monitored.
- Solenoid drive output is provided, eliminating the need for PLC.
- IEC 61508 integrity level 3, ISO 13849-1 performance level e, and EN954-1 safety category 4 compliant



## Types

Product	Ordering Type No.
SafetyOne	FS1A-C01S

### • Standard Accessories

Input connector (FS9Z-CN01)	1 pc
Output connector (FS9Z-CN02)	1 pc
Marked cable tie (FS9Z-MT01)	3 pcs
Setting tool	1 pc
Instruction sheet (B-1088, English)	1 pc
Instruction sheet (B-1087, Japanese)	1 pc

### • Optional Parts (sold separately)

Product	Ordering Type No.	Package Quantity	Note
Connector	For input FS9Z-CN01	1	
	For output FS9Z-CN02	1	
Connecting Tool	FS9Z-SD01	1	
Marked Cable Tie	FS9Z-MT01PN10	10	Used to lock the protection cover of the FS1A.
DIN Rail	BAA1000PN10	10	Aluminum, 1m 35mm wide
Mounting Clip	BNL6PN10	10	

• For details, see the user's manual.

## Specifications

### • Operating Environment

Safety Circuit	Logic selection type
Operating Temperature	-10 to +55°C (no freezing)
Operating Humidity	10 to 95% RH (no condensation)
Storage Temperature	-40 to +70°C (no freezing)
Storage Humidity	10 to 95% RH (no condensation)
Pollution Degree	2 (IEC/EN60664-1)
Degree of Protection	IP20 (IEC/EN60529)
Corrosion Immunity	Free from corrosive gases
Altitude	Operation: 0 to 2000m, Transport: 0 to 3000m
Vibration Resistance	Vibration: 5 to 8.4 Hz, amplitude 3.5 mm 8.4 to 150 Hz
	Acceleration: 9.8 m/s <sup>2</sup> (2 hours each on three mutually perpendicular axes) (IEC/EN61131-2)
	Bump: Acceleration 98 m/s <sup>2</sup> , 16 ms (1000 times each on three mutually perpendicular axes) (IEC/EN61496-1)
Shock Resistance	147 m/s <sup>2</sup> , 11 ms (3 shocks each on three mutually perpendicular axes (IEC/EN 61131-2)
Connector Insertion/Removal Durability	50 times maximum
Configuration Switch Durability	100 operations maximum per pole
Enter Button Durability	1000 operations maximum
Housing Material	Modified-polyphenyleneether (m-PPE)
Weight (approx.)	330g



### • Electric Characteristics

Rated Voltage	24V DC
Allowable Voltage Range	20.4 to 28.8V DC
Maximum Power Consumption	48W (at the rated power voltage, when all I/Os are ON) (incl. output load)
Allowable Momentary Power Interruption	10 ms minimum (at the rated power voltage)
Response Time	ON-OFF: 40 ms maximum (Note 1)/ 100 ms maximum (Note 2) OFF-ON: 100 ms maximum (Note 3)
Start-up Time (Note 4)	6s maximum
Dielectric Strength	Between live part and FE terminal: 500V AC, 1 minute
	Between housing and FE terminal: 500V AC, 1 minute
Insulation Resistance	Between live part and FE terminal: 10 MΩ minimum (500V DC megger)
	Between housing and FE terminal: 10 MΩ minimum (500V DC megger)
Impulse Noise Immunity (noise simulator)	Power terminal: ±1 kV 50ns, 1μs (direct connection) I/O terminal: ±1kV 50ns, 1μs (coupling adapter)
Inrush Current	25A maximum
Ground	Ground resistance of 100Ω or less
Effect of Incorrect Wiring	Reverse polarity: No operation, no damage Improper voltage: Permanent damage may occur

Note 1: The time to shut off safety outputs after inputs are turned off or input monitor error is detected (when off-delay timer is set to 0s)

Note 2: Time to shut off safety outputs after an error (except input monitor error) or a configuration change of logic or timer is detected (not depending on the off-delay timer value)

Note 3: Auto start—Time to turn on safety outputs after safe inputs are turned on  
Manual start—Time to turn on safety outputs after start inputs are turned on  
Control start—Time to turn on safety outputs after the start inputs are turned off-on-off (maintain ON for 0.1 to 5s)

Note 4: Time to transit to Run state after power supply is turned on.

### TÜV approval:

IEC/EN 61000-6-2, IEC/EN 61000-6-4, IEC/EN 61496-1, IEC 61508 Part1-7, IEC/EN 62061, ISO 13849-1, EN 954-1

### UL:

UL508, CSA C22.2 No. 142

### Applicable standards:

IEC/EN 60204-1, IEC/EN 61131-2, ISO 10218-1, ANSI/RIA R15.06, ANSI B11.19, SEMI S2-0706, NFPA79

## Safety Input Specifications

### • Drive Terminals

(T0, T1, T2, T3, T4, T5, T6, T7, T10, T11, T12, T13, T14, T15)

Rated Drive Voltage	Power supply voltage
Minimum Drive Voltage	Power supply voltage – 2.0V
Number of Drive Terminals	14
Maximum Drive Current	20 mA per terminal (28.8V DC) (Note)

Note: Drive terminals of safety inputs send safety confirmation signals (pulse signals) for the diagnosis of safety components and input circuits. (Wiring and diagnosis function change depending on the selected logic. See user's manual "Chapter 5 Logic." Basic specifications remain the same.

### • Receive Terminals

(X0, X1, X2, X3, X4, X5, X6, X7, X10, X11, X12, X13, X14, X15)

Rated Input Voltage	24V DC
Input ON Voltage	15.0 to 28.8V DC
Input OFF Voltage	Open or 0 to 5.0V DC
Number of Inputs	14
Input Current	10 mA per terminal (at the rated power voltage)
Input Signal	Sink input (for PNP output), Type 1 (IEC61131-2)

### • Wire

Cable Length (Note)	100m maximum (total wire length per input)
Allowable Wire Resistance	300Ω maximum

Note: When the wiring between the SafetyOne and the connected component is 30m or more, use a shielded cable to ensure electromagnetic immunity.

### • Receive Terminal Internal Circuit

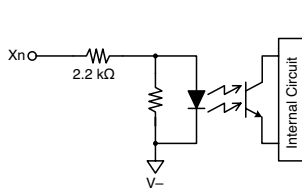

### • Receive Terminal Operating Range

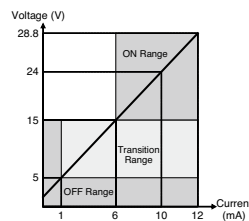

## Start Input Specifications

Rated Input Voltage	24V DC
Input ON Voltage	15.0 to 28.8V DC
Input OFF Voltage	Open or 0V to 5.0V DC
Number of Start Inputs	2 (X16, X17)
Input Current	5 mA per terminal (at the rated power voltage)
Input Signal	Sink input (PNP output), Type 1 (IEC61131-2)
Cable Length (Note)	100m maximum (total wire length per input)
Allowable Wire Resistance	300Ω maximum

Note: When the wiring between the SafetyOne and the connected component is 30m or more, use a shielded cable to ensure electromagnetic immunity.

### • Start Input Internal Circuit

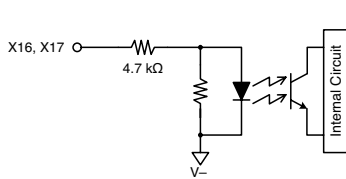

### • Start Input Operation Range

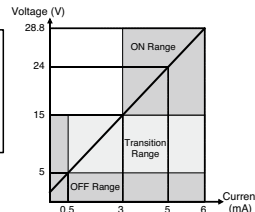

## Safety Output Specifications

Output Type	Source output (N channel MOSFET)	
Rated Output Voltage	Power supply voltage	
Minimum Output Voltage	Power supply voltage – 2.0V	
Number of Safety Outputs	4 (Y0, Y1, Y2, Y3)	
Maximum Output Current	1 output	500 mA maximum
	Total	1A maximum
Leakage Current	0.1 mA maximum	
Allowable Inductive Load (Note 1)	L/R = 25 ms	
Allowable Capacitive Load	1 μF maximum	
Cable Length (Note 2)	100m maximum (total length per output)	

Note 1: When connecting an inductive load, connect a protection element such as a diode.

Note 2: When the wiring between the SafetyOne and the connected component is 30m or more, use a shielded cable to ensure electromagnetic immunity.

### • Safety Output Internal Circuit

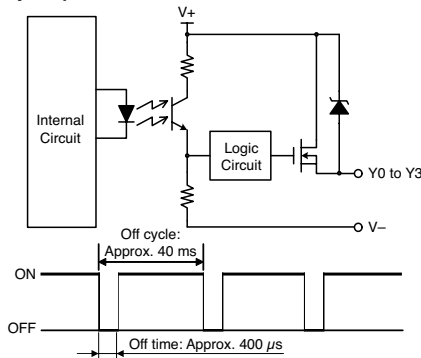

The safety outputs of the SafetyOne are solid state outputs. When the output is on, off-check signals are generated at regular intervals. The operating characteristics of the safety output change depending on the selected logic. For details, see user's manual "Chapter 5 Logic." The basic specifications remain the same.

Note that off-check signals may cause reaction of some safety components depending on their response speed.

Monitor output and solenoid/lamp output do not generate outputs of off-check signals.

## Monitor Output Specifications

Output Type	Source output (N channel MOSFET)	
Rated Output Voltage	Power supply voltage	
Minimum Output Voltage	Power supply voltage – 2.0V	
Number of Monitor Outputs	11 (Y4, Y5, Y6, Y7, Y10, Y11, Y12, Y13, Y14, Y15, Y16)	
Maximum Output Current	1 output	20 mA maximum
	Total	220 mA maximum
Leakage Current	0.1 mA maximum	
Cable Length (Note)	100m maximum (total length per output)	

Note: When the wiring between the SafetyOne and the connected component is 30m or more, use a shielded cable to ensure electromagnetic immunity.

### • Monitor Output Internal Circuit

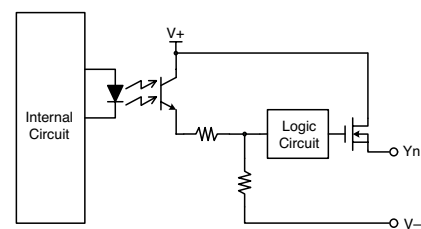

The operating characteristics of the monitor output change depending on the selected logic. For details, see user's manual "Chapter 5 Logic." The basic specifications remain the same.

Do not use monitor output as safety output, otherwise the system's safety cannot be assured when the SafetyOne or safety components fail.

## Solenoid/Lamp Output Specifications

Output Type	Source output (N channel MOSFET)	
Rated Output Voltage	Power supply voltage	
Minimum Output Voltage	Power supply voltage – 2.0V	
No. of Solenoid/Lamp Outputs	2 (Y17, Y20)	
Maximum Output Current	1 output	500 mA maximum
	Total	500 mA maximum
Leakage Current	0.1 mA maximum	
Allowable Inductive Load (Note 1)	L/R = 25 ms	
Cable Length (Note 2)	100m maximum (total length per output)	

Note 1: When connecting an inductive load, connect a protection element such as a diode.

Note 2: When the wiring between the SafetyOne and the connected component is 30m or more, use a shielded cable to ensure electromagnetic immunity.

### • Solenoid/Lamp Output Internal Circuit

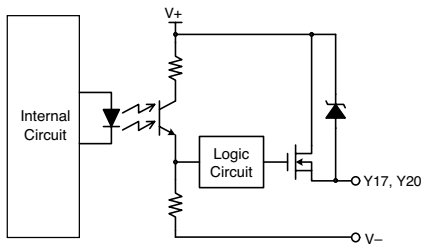

The selected operating characteristics of solenoid/lamp output change depending on the selected logic. For details, see user's manual "Chapter 5 Logic." The basic specifications remain the same. Do not use solenoid/lamp output as safety output, otherwise the system's safety cannot be assured when the SafetyOne or safety components fail.

## Internal States

State	Description
Initial	Initial processing is performed immediately after power is supplied to the SafetyOne. The internal circuits are checked and the LEDs show operation confirmation (blinking) for 6 seconds (approx).
Run	The SafetyOne is under normal operation. Logic processing continues without failures or wiring errors.
Configuration	A logic or off-delay timer value is being configured. Configuration enables the logic and off-delay timer value. When completed, the SafetyOne shifts to the Run state.
Protection	An input monitor error has occurred with dual channel input, EDM input, or muting input. When the problem is removed, the SafetyOne shifts to Run state.
Stop	A failure or error has occurred with an external device or internal circuit. When the problem is removed and the power is turned on, Stop state is cleared.

## LED and Output Status

State	Logic LED	Error LED	Timer LED	Safety Output	Solenoid/Lamp Output	Monitor Output			
				Y0 to Y3	Y17, Y20	Y4 to Y13	Y14	Y15	Y16
Initial	(Note 1)	(Note 1)	(Note 1)	OFF	OFF	OFF	ON	ON	OFF
Run	Logic #	Blank	Value	(Note 2)	(Note 2)	(Note 2)	OFF	OFF	ON
Configuration	(Note 3)	C	(Note 3)	OFF	OFF	OFF	OFF	ON	OFF
Protection	Logic #	1	Value	OFF	OFF	(Note 4)	OFF	ON	OFF
Stop	Blank	(Note 5)	Blank	OFF	OFF	OFF	ON	ON or OFF	OFF

Note 1: Random display of Initial state.

Note 2: Output and LED display of the selected logic.

Note 3: Blinking LED display of the selected logic number or the selected timer value.

Note 4: Pulsing display of monitor output and output LED corresponding to the input of error. Other LEDs and monitor outputs maintain the display of Run state.

Note 5: Error number is displayed.

### Caution

Solenoid/lamp outputs (Y17, Y20) turn on for 1 second maximum when the state shifts to Run state. Take the operation of the connected components into consideration.

## LEDs

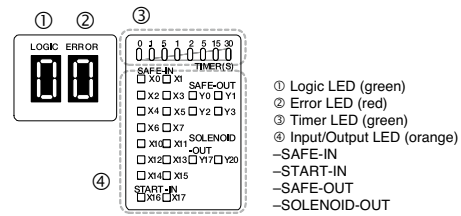

- ① Logic LED (green)
- ② Error LED (red)
- ③ Timer LED (green)
- ④ Input/Output LED (orange)

### • Logic LED ①

LED	Status	Description
1 to 8	ON	The selected logic is in Run or Protection state
	Blink	The selected logic is in Configuration state
E	Blink	The selected logic has Configuration error (logic not selected, or more than one logics are selected)
Random	ON/Blink	Initializing (Initial state)
OFF	OFF	Error (Stop state)

### • Error LED ②

LED	Status	Description
1	ON	Input monitor error (Protection state)
2	ON	Wiring error at safety input or an error in safety input circuits
3	ON	Wiring error at start input or an error in start input circuit
4	ON	Wiring error at safety output or an error in safety output circuit
5	ON	Muting lamp error (disconnection) (Logic 4 only)
6	ON	Power supply error or internal power supply circuit error
7	ON	Internal error, power supply error, or internal power supply circuit error
9	ON	EMC disturbance
C	ON	Configuration procedure is in progress (Configuration state)
	Blink	Configuration is valid (Note) (Configuration state)
Random	ON/Blink	Initializing (Initial state)
OFF	OFF	Normal operation (Run state)

Note: Blinks for 1 to 5 seconds after the enter button is pressed. Releasing the button during blinking activates the setting. The blinking LED becomes ON if the button is pressed for more than 5 seconds, and the setting becomes invalid even after the button is released.

### • Timer LED ③

LED	Status	Description
0	ON	No off-delay (safety outputs shut down immediately)
.1	ON	Off-delay timer 0.1s
.5	ON	Off-delay timer 0.5s
1	ON	Off-delay timer 1s
2	ON	Off-delay timer 2s
5	ON	Off-delay timer 5s
15	ON	Off-delay timer 15s
30	ON	Off-delay timer 30s
Each LED	Blink	Selected timer value (Configuration state)
Random	ON/Blink	Initializing (Initial state)
All LEDs	OFF	Timer value is not selected or the SafetyOne is in Stop state

### • Input LED ④

#### SAFE-IN (X0 to X15), START-IN (X16, X17)

LED	Status	Description
X0 to X15	ON	Input ON
	OFF	Input OFF, Stop/Configuration state
	Blink	Input monitor error
X16, X17	ON	Input ON
	OFF	Input OFF, Stop/Configuration state

### • Output LED ④

#### SAFE-OUT (Y0 to Y3), SOLENOID-OUT (Y17, Y20)

LED	Status	Description
Y0 to Y3	ON	Output ON
	OFF	Output OFF, Stop/Configuration state
	Blink	Off-delay operating
Y17, Y20	ON	Output ON
	OFF	Output OFF, Stop/Configuration state

## Configuration Switches

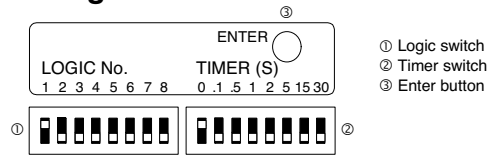

### Logic Switch ①

Eight DIP switches are provided for selecting a logic by moving a switch upward. For details, See user's manual "Chapter 5 Logic." Only one logic switch can be selected.

### Timer Switch ②

Eight DIP switches are provided for selecting an off-delay timer value, by moving a switch upward. For details, See user's manual "Chapter 5 Logic." Only one timer switch can be selected.

Switch No.	Timer Value	Description
1	0	No off-delay (safety outputs shut down immediately)
2	.1	Off-delay timer 0.1s
3	.5	Off-delay timer 0.5s
4	1	Off-delay timer 1s
5	2	Off-delay timer 2s
6	5	Off-delay timer 5s
7	15	Off-delay timer 15s
8	30	Off-delay timer 30s

### Enter Button ③

The enter button is used to activate the configuration of logic and timer switches. Error LED will blink for 1 to 5 seconds after pressing the enter button. Releasing the button during blinking activates the setting. The blinking LED becomes ON if the button is pressed for more than 5 seconds, and the setting becomes invalid even after the button is released. For setting the switches and enter button, use the setting tool supplied with the SafetyOne.

## Connector Specifications

### • Input Connector

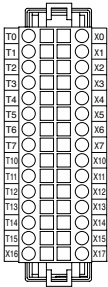

#### Applicable connector

Spring clamp (30-pin)  
FS9Z-CN01 (IDEC)  
2-1871940-5 (Tyco Electronics)  
Crimp (30-pin)  
2-1871946-5 (Tyco Electronics)

Terminal	No.	Description
T0	A1	Safety input drive terminal 0
T1	A2	Safety input drive terminal 1
T2	A3	Safety input drive terminal 2
T3	A4	Safety input drive terminal 3
T4	A5	Safety input drive terminal 4
T5	A6	Safety input drive terminal 5
T6	A7	Safety input drive terminal 6
T7	A8	Safety input drive terminal 7
T10	A9	Safety input drive terminal 10
T11	A10	Safety input drive terminal 11
T12	A11	Safety input drive terminal 12
T13	A12	Safety input drive terminal 13
T14	A13	Safety input drive terminal 14
T15	A14	Safety input drive terminal 15
X16	A15	Start input terminal 16

Terminal	No.	Description
X0	B1	Safety input receive terminal 0
X1	B2	Safety input receive terminal 1
X2	B3	Safety input receive terminal 2
X3	B4	Safety input receive terminal 3
X4	B5	Safety input receive terminal 4
X5	B6	Safety input receive terminal 5
X6	B7	Safety input receive terminal 6
X7	B8	Safety input receive terminal 7
X10	B9	Safety input receive terminal 10
X11	B10	Safety input receive terminal 11
X12	B11	Safety input receive terminal 12
X13	B12	Safety input receive terminal 13
X14	B13	Safety input receive terminal 14
X15	B14	Safety input receive terminal 15
X17	B15	Start input terminal 17

### • Output Connector

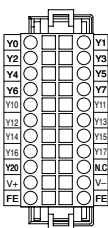

#### Applicable connector

Spring clamp (22-pin)  
FS9Z-CN02 (IDEC)  
2-1871940-1 (Tyco Electronics)  
Crimp (22-pin)  
2-1871946-1 (Tyco Electronics)

Terminal	No.	Description
Y0	A1	Safety output terminal 0
Y2	A2	Safety output terminal 2
Y4	A3	Monitor output terminal 4
Y6	A4	Monitor output terminal 6
Y10	A5	Monitor output terminal 10
Y12	A6	Monitor output terminal 12
Y14	A7	Monitor output terminal 14
Y16	A8	Monitor output terminal 16
Y20	A9	Solenoid/lamp output terminal 20
V+	A10	24V DC power terminal
FE	A11	Functional ground terminal

Terminal	No.	Description
Y1	B1	Safety output terminal 1
Y3	B2	Safety output terminal 3
Y5	B3	Monitor output terminal 5
Y7	B4	Monitor output terminal 7
Y11	B5	Monitor output terminal 11
Y13	B6	Monitor output terminal 13
Y15	B7	Monitor output terminal 15
Y17	B8	Solenoid/lamp output terminal 17
NC	B9	Blank terminal
V-	B10	0V DC power terminal
FE	B11	Functional ground terminal

Note: For the specifications of crimp connector, contact Tyco Electronics.



## Logic 1

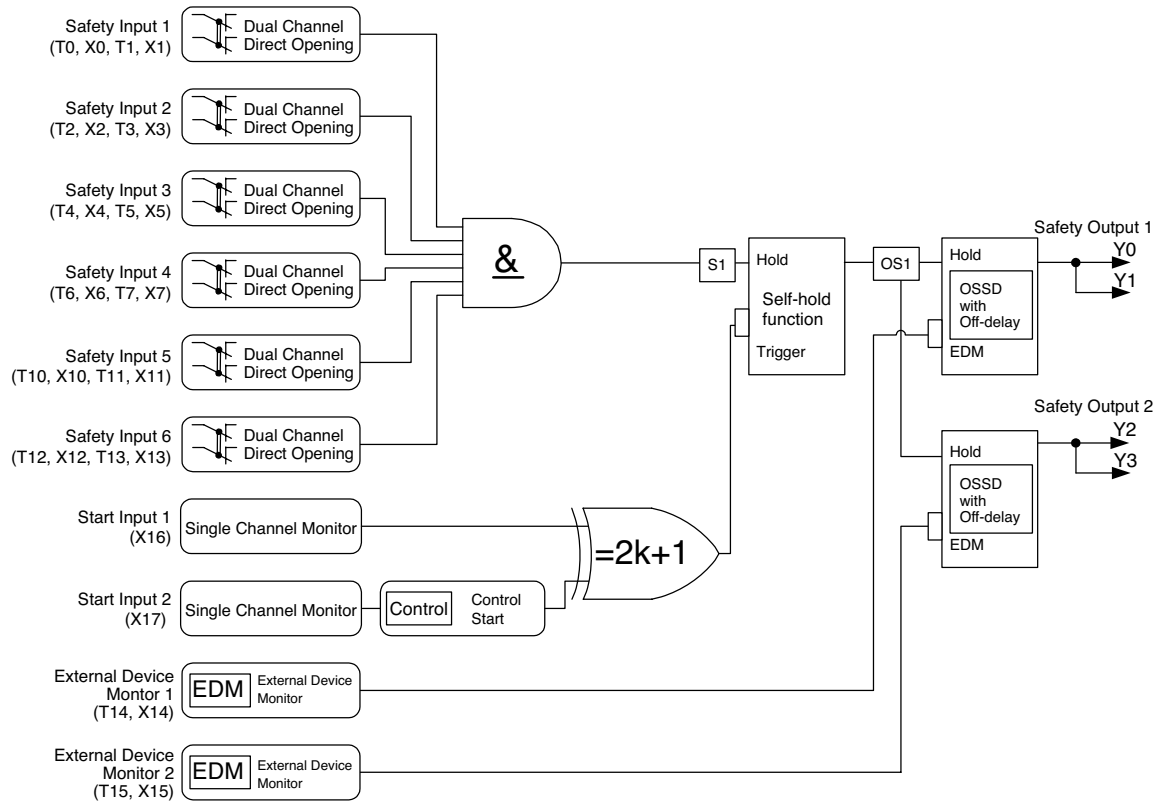

### • Monitor Output for Safety Input

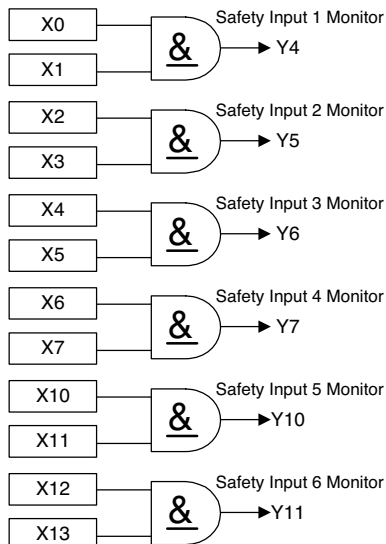

### • Monitor Output for Safety Output

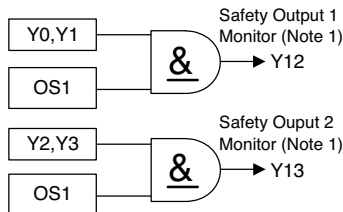

Note 1: Safety output 1 monitor and safety output 2 monitor turn off immediately independent of off-delay time.

### • Solenoid Output (Note 2)

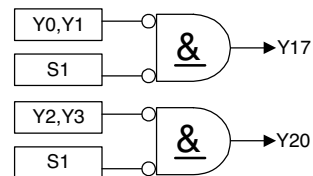

Note 2: In Run state, the solenoid output turns on when the safety output is off and one or more corresponding safety inputs are off. When all corresponding safety inputs are on, the solenoid outputs are turned off even when the start input is off.

## Logic 1 Wiring Example

When using four emergency stop switches and two spring-lock type interlock switches with solenoid

- S1 to S4: Emergency stop switch
- S5, S6: Interlock switch with solenoid (spring lock type)
- S7: Start switch
- K1 to K4: Safety contactor
- M1, M2: Motor
- S8, S9: Solenoid control switch  
(Pressing the solenoid control switches after closing the guard door, contacts 41-42 and 51-52 of S5 and S6 turn on, allowing the SafetyOne to restart.)

### Safety components used in this system

- Emergency stop switch: XA1E, XW1E, XN1E, HA1B, HA1E, HW1B, HW1E
- Interlock switch with solenoid (spring lock type): HS6E
- Non-contact safety switch (2NO type): HS7A
- Interlock switch: HS6B, HS5B

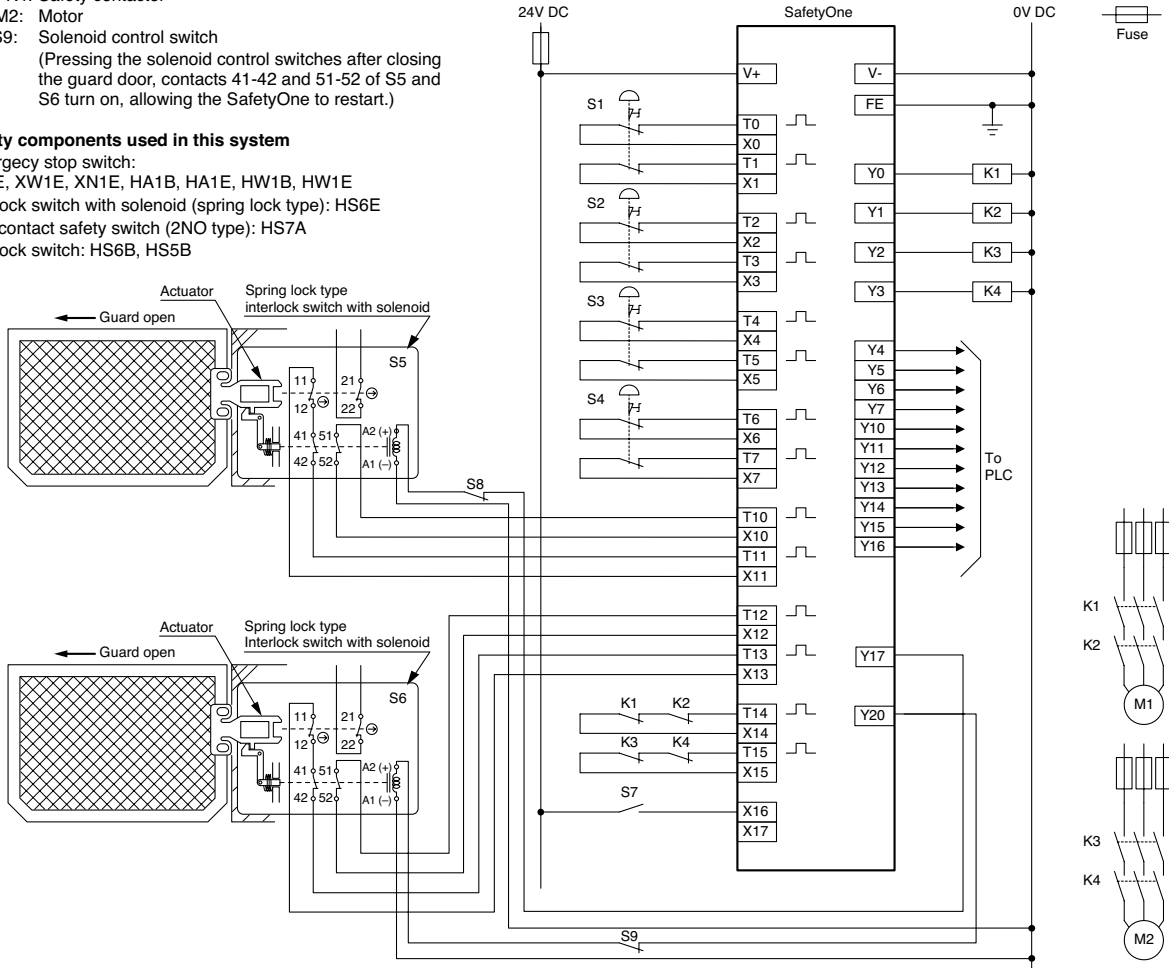

When not using the start switch (auto start)

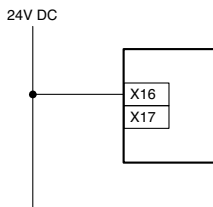

When not detecting the welding of start switch (manual start)

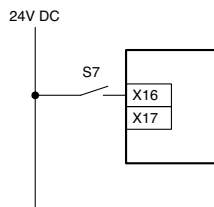

When detecting the welding of start switch (control start)

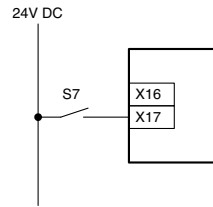

When connecting multiple emergency stop switches in series

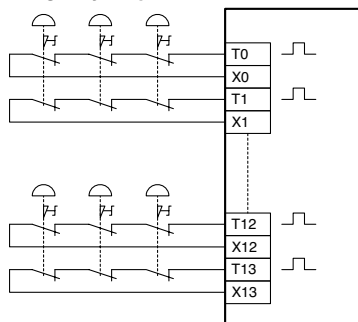

Note:  
Safety performance depends on the system configuration.

When not using some inputs

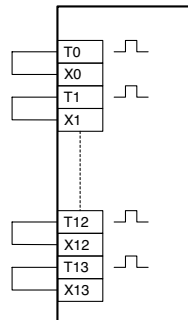

## • Logic 1 Time Chart

### When using manual start input X16

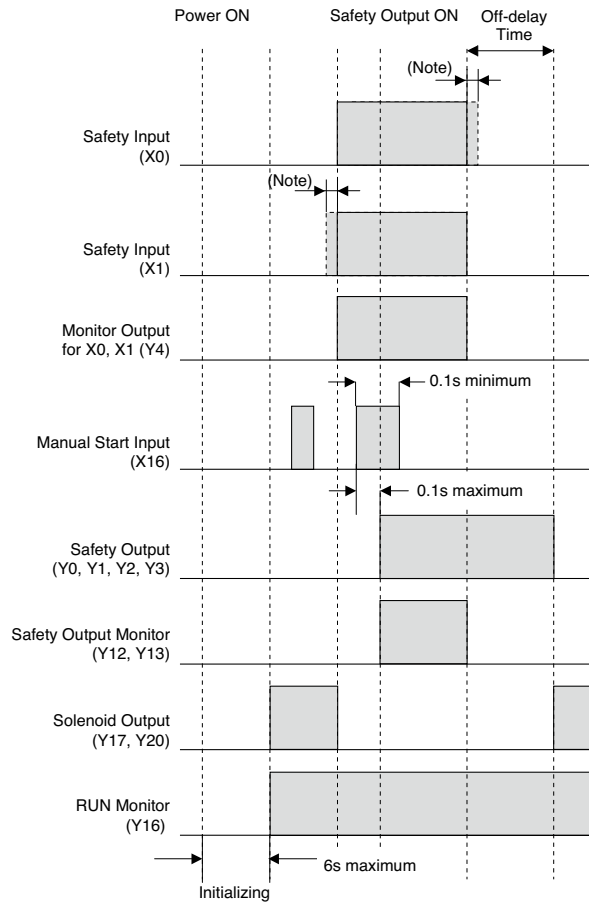

Note: When the input time difference at the dual channel safety inputs is 0.5s or more, the input monitor error is detected.

### When using control start input X17

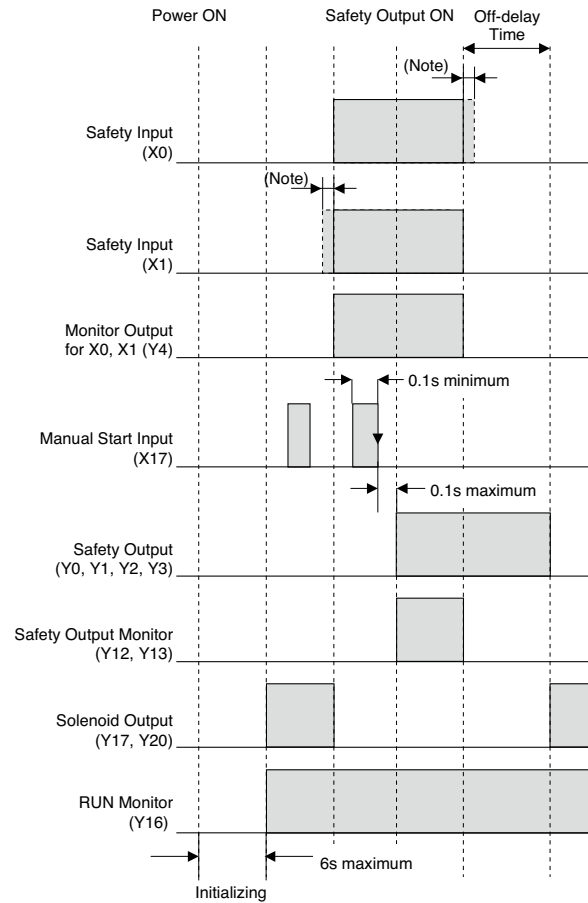

(Safety inputs X2 to X13 are ON in this chart)

## Logic 2

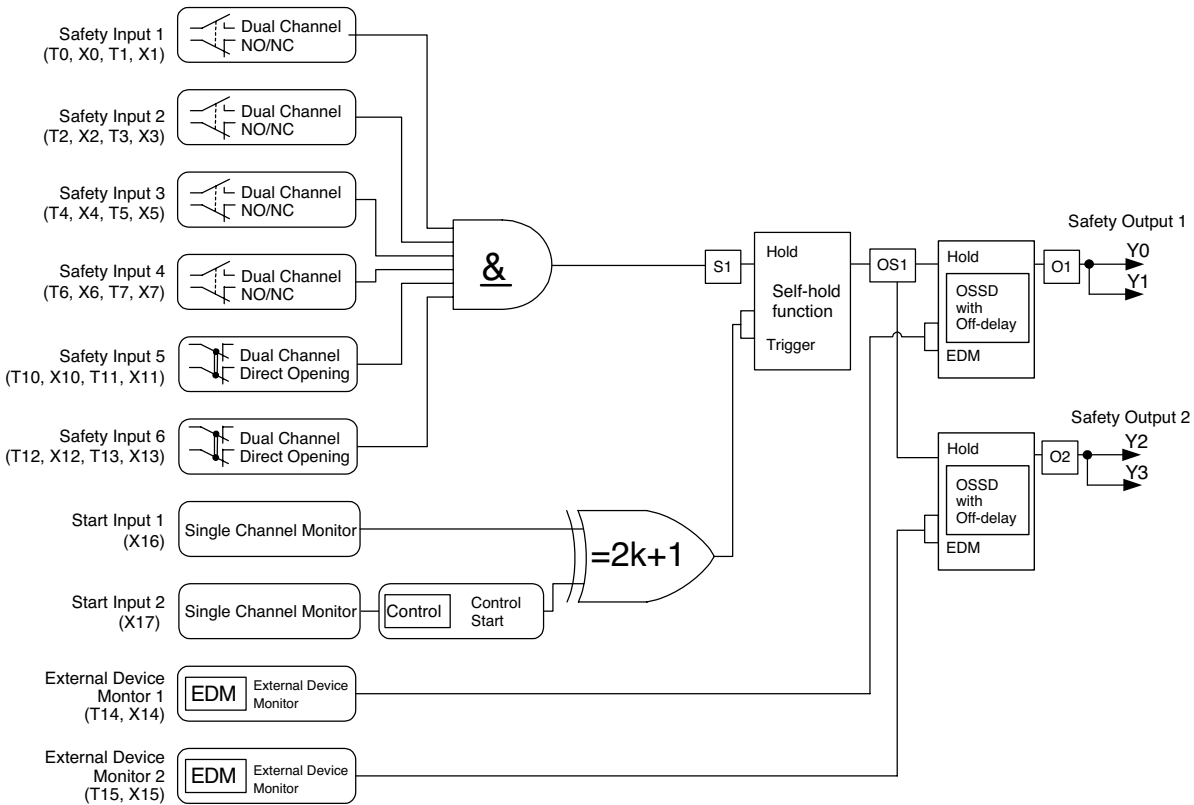

### • Monitor Output for Safety Input

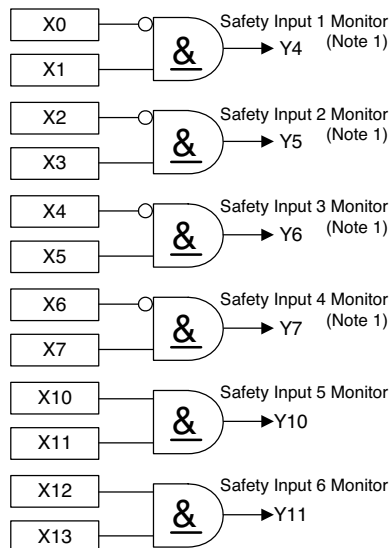

Note 1: When  $X_n$  is off and  $X_{n+1}$  is on, safety input monitor 1 to 4 turn on.  
( $n = 0, 2, 4, 6$ )

### • Monitor Output for Safety Output

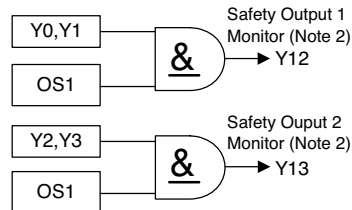

Note 2: Safety output 1 monitor and safety output 2 monitor turn off immediately independent of off-delay time.

### • Solenoid Output (Note 3)

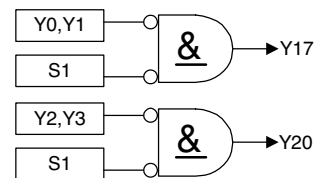

Note 3: In Run status, the solenoid output turns on when the safety output is off and one or more corresponding safety inputs are off. When all corresponding safety inputs are on, the solenoid output is turned off even when the start input is off.



## • Logic 2 Wiring Example

When connecting four non-contact interlock switches, an emergency stop switch, and a spring-lock type interlock switch with solenoid

- S1 to S4: Non-contact interlock switch
- S5: Emergency stop switch
- S6: Interlock switch with solenoid (spring lock type)
- S7: Start switch
- K1 to K4: Safety contactor
- M1, M2: Motor
- S8: Solenoid control switch  
(Pressing the solenoid control switch after closing the guard door, contacts 41-42 and 51-52 of S6 turn on, allowing the SafetyOne to restart.)

### Safety components used in this system

- Emergency stop switch: XA1E, XW1E, XN1E, HA1B, HA1E, HW1B, HW1E
- Interlock switch with solenoid (spring lock type): HS6E, HS5E
- Non-contact safety switch (1NC+1NO type): HS7A
- Interlock switch: HS6B, HS5B

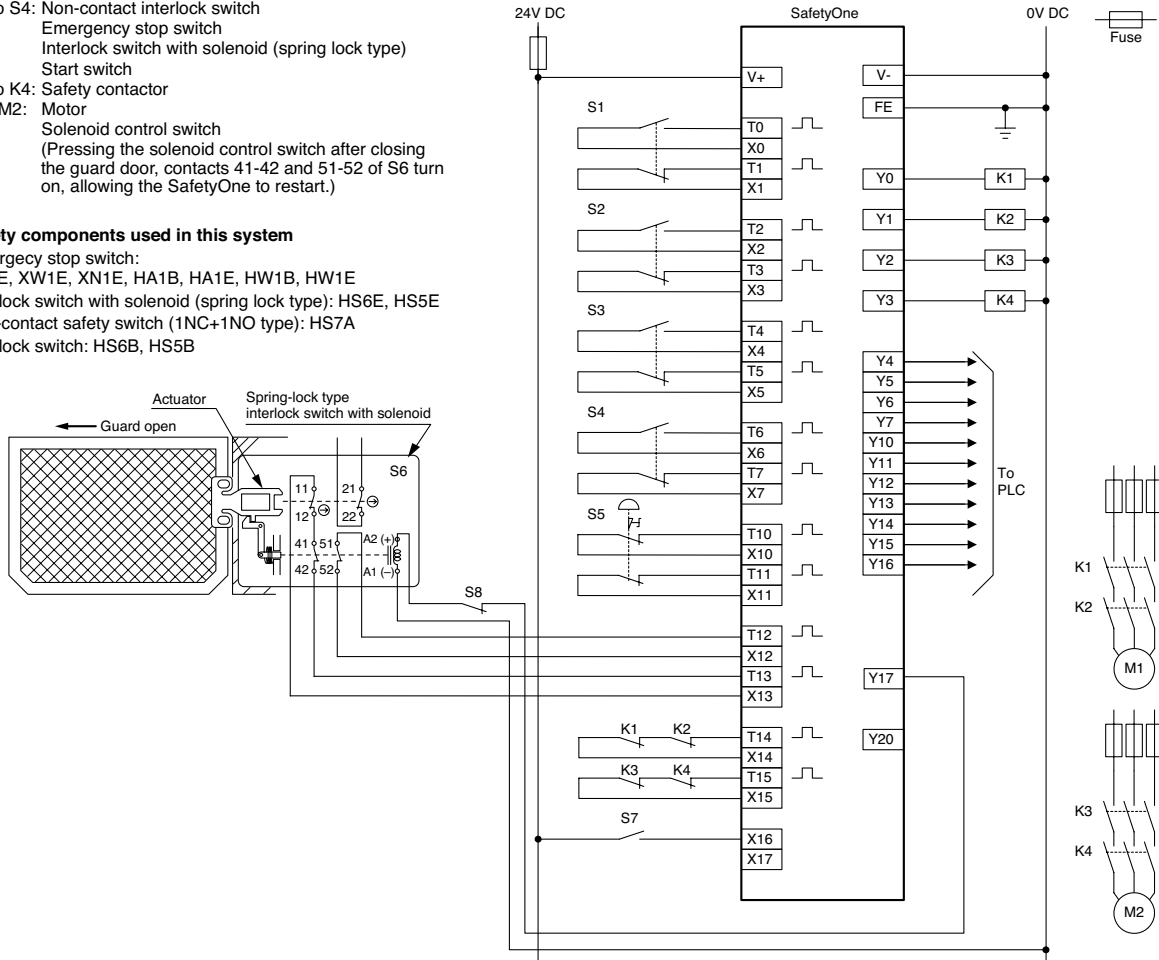

### When not using the start switch (auto start)

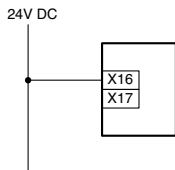

### When not detecting the welding of start switch (manual start)

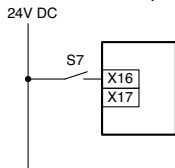

### When detecting the welding of start switch (control start)

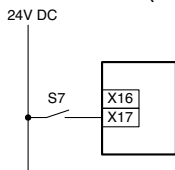

### When connecting multiple components in series

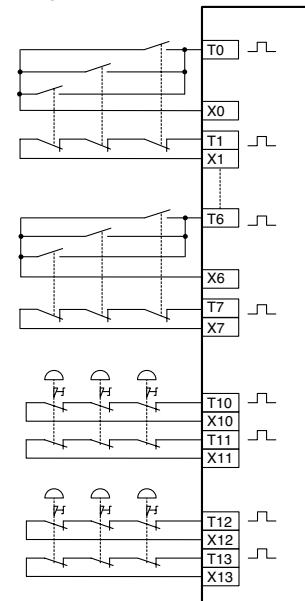

### When not using some safety inputs

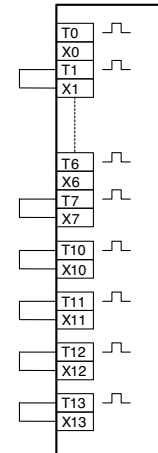

Note:  
Safety performance depends on the system configuration.

## • Logic 2 Time Chart

### When using manual start input X16

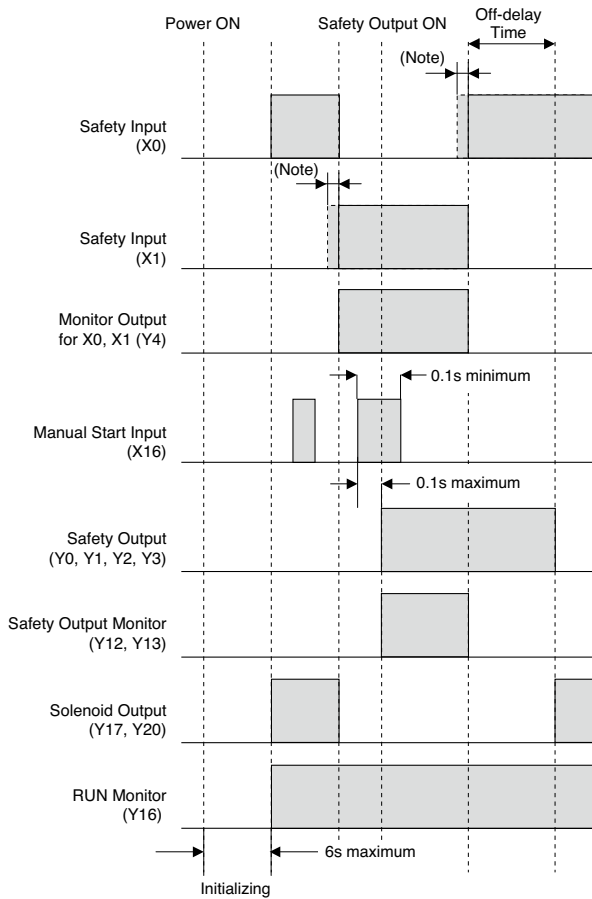

### When using control start input X17

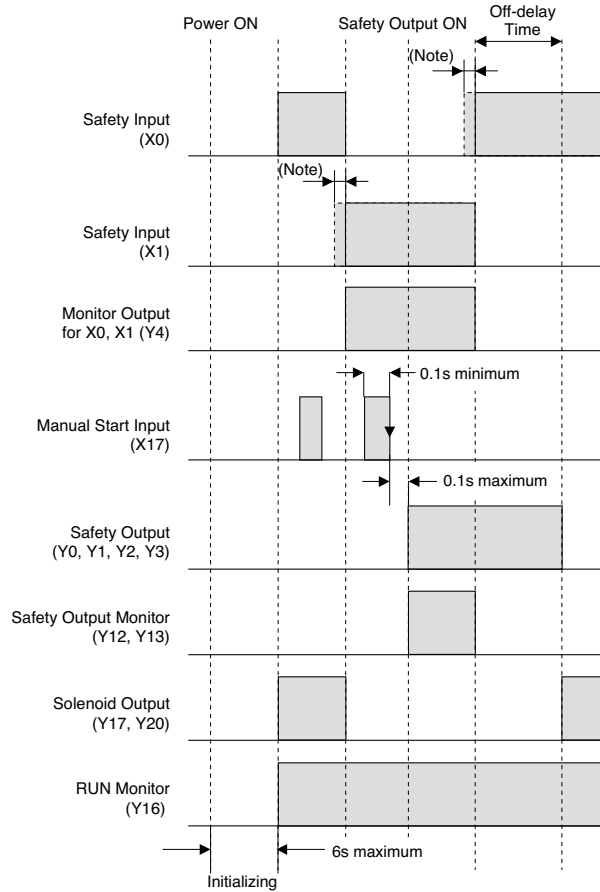

## Logic 3

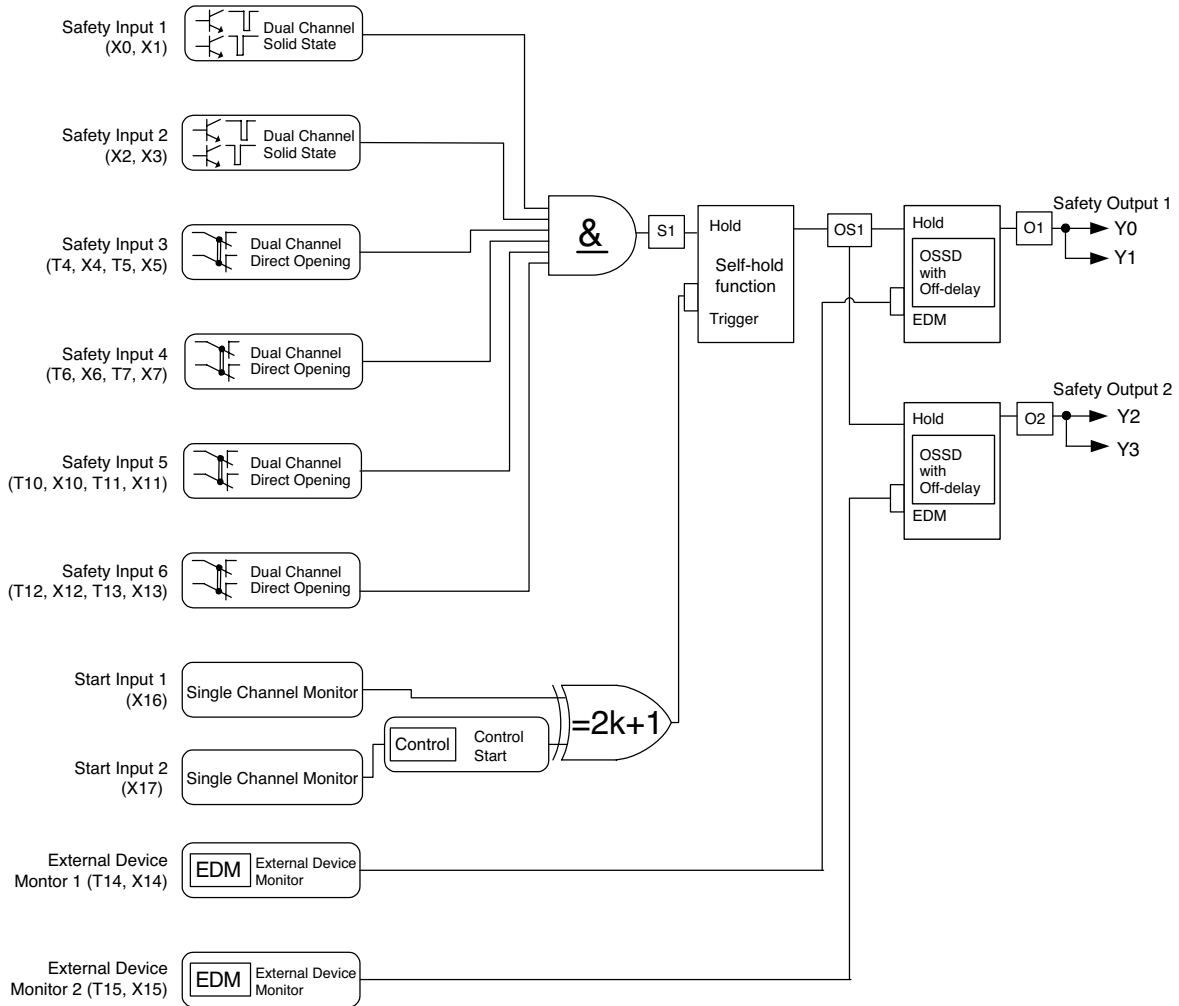

### • Monitor Output for Safety Input

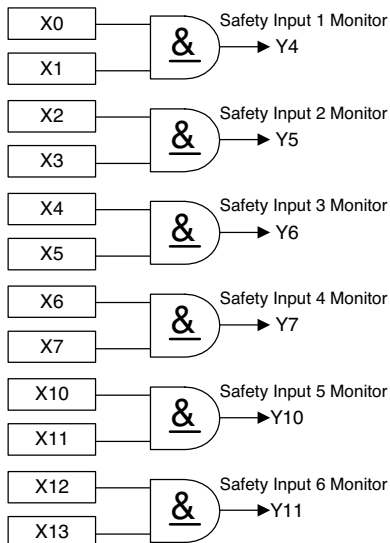

### • Monitor Output for Safety Output

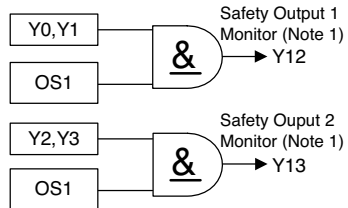

Note 1: Safety output 1 monitor and safety output 2 monitor turn off immediately independent of off-delay time.

### • Solenoid Output (Note 2)

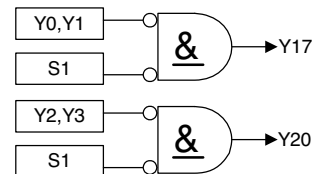

Note 2: Auto mode  
In Run status, the solenoid output turns on when the safety output is off and one or more corresponding safety inputs are off. When all corresponding safety inputs are on, the solenoid output is turned off even when the start input is off.

## Logic 3 Wiring Example

When wiring two light curtains (PNP), two emergency stop switches, and two interlock switches with solenoid (spring lock type)

- S1, S2: Light curtain (PNP type)
  - S3, S4: Emergency stop switch
  - S5, S6: Interlock switch with solenoid (spring lock type)
  - S7: Start switch
  - K1 to K4: Safety contactor
  - M1, M2: Motor
  - S8, S9: Solenoid control switch
- (Pressing the solenoid control switches after closing the guard door, contacts 41-42 and 51-52 of S5 and S6 turn on, allowing the SafetyOne to restart.)

### Safety components used in this system

- Emergency stop switch: XA1E, XW1E, XN1E, HA1B, HA1E, HW1B, HW1E
- Interlock switch with solenoid (spring lock type): HS6E
- Light curtain (PNP type): SE4B
- Non-contact safety switch (2NO type): HS7A
- Interlock switch: HS6B, HS5B

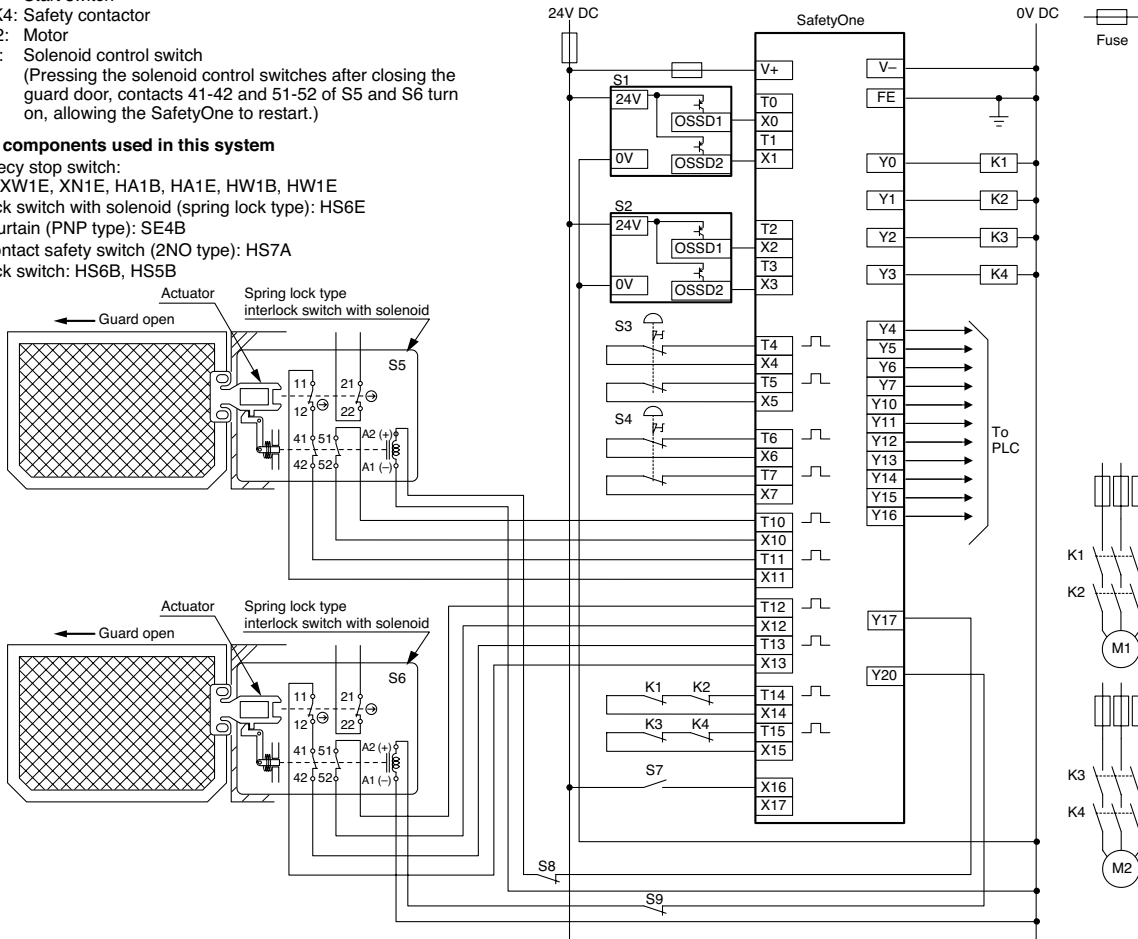

### When using IDEC's SE4B light curtain for S1 and S2

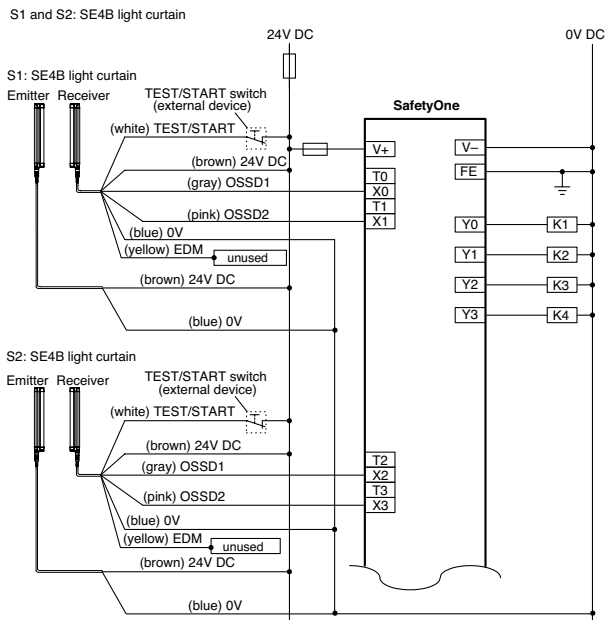

### When not using the start switch (auto start)

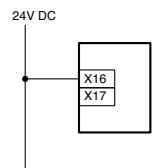

### When not detecting the welding of start switch (manual start)

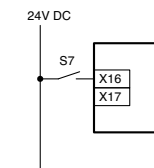

### When detecting the welding of start switch (control start)

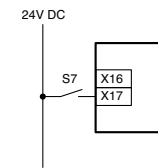

### When connecting multiple emergency stop switches in series

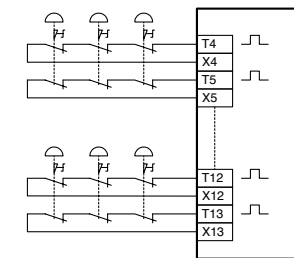

Note:  
Safety performance depends on the system configuration.

### When not using some safety inputs

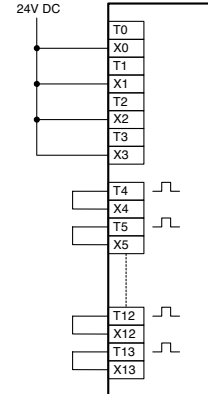

## • Logic 3 Time Chart

### When using manual start input X16

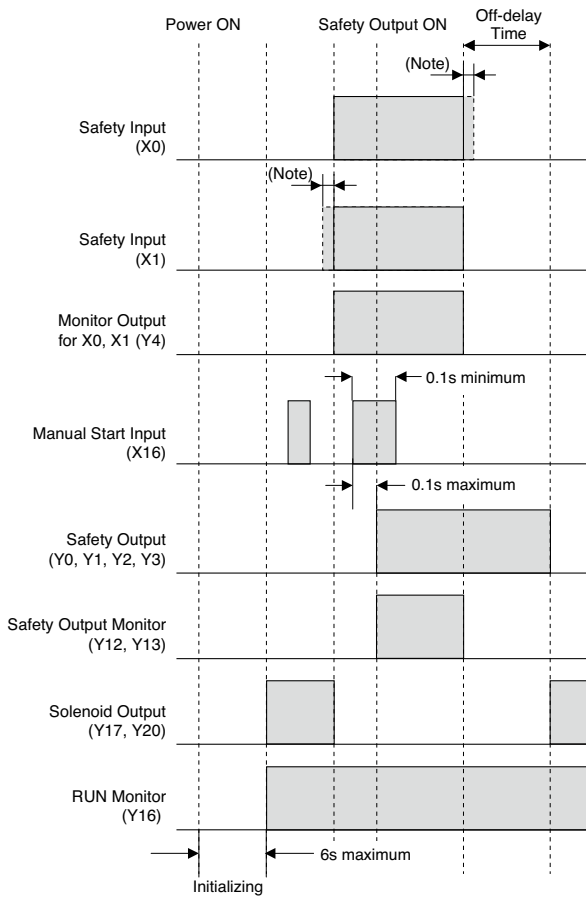

Note: When the input time difference at the dual channel solid state inputs (X0-X1 and X2-X3) is 0.1s or more, the input monitor error is detected. When the input time difference at the dual channel direct opening inputs (X4-X5, X6-X7, X12-X13) is 0.5s or more, the input monitor error is detected.

### When using control start input X17

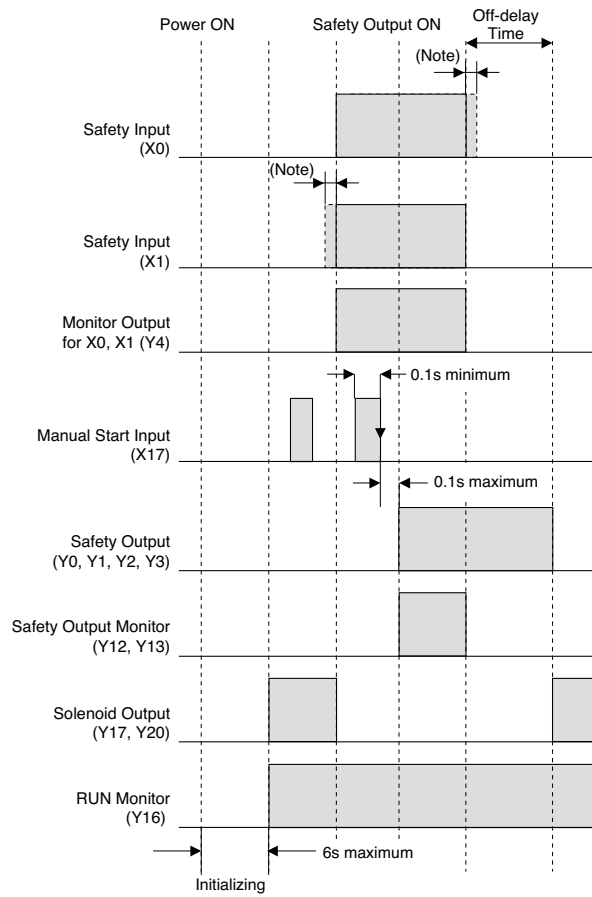

(Safety inputs X2 to X13 are ON in this chart.)



## Logic 4

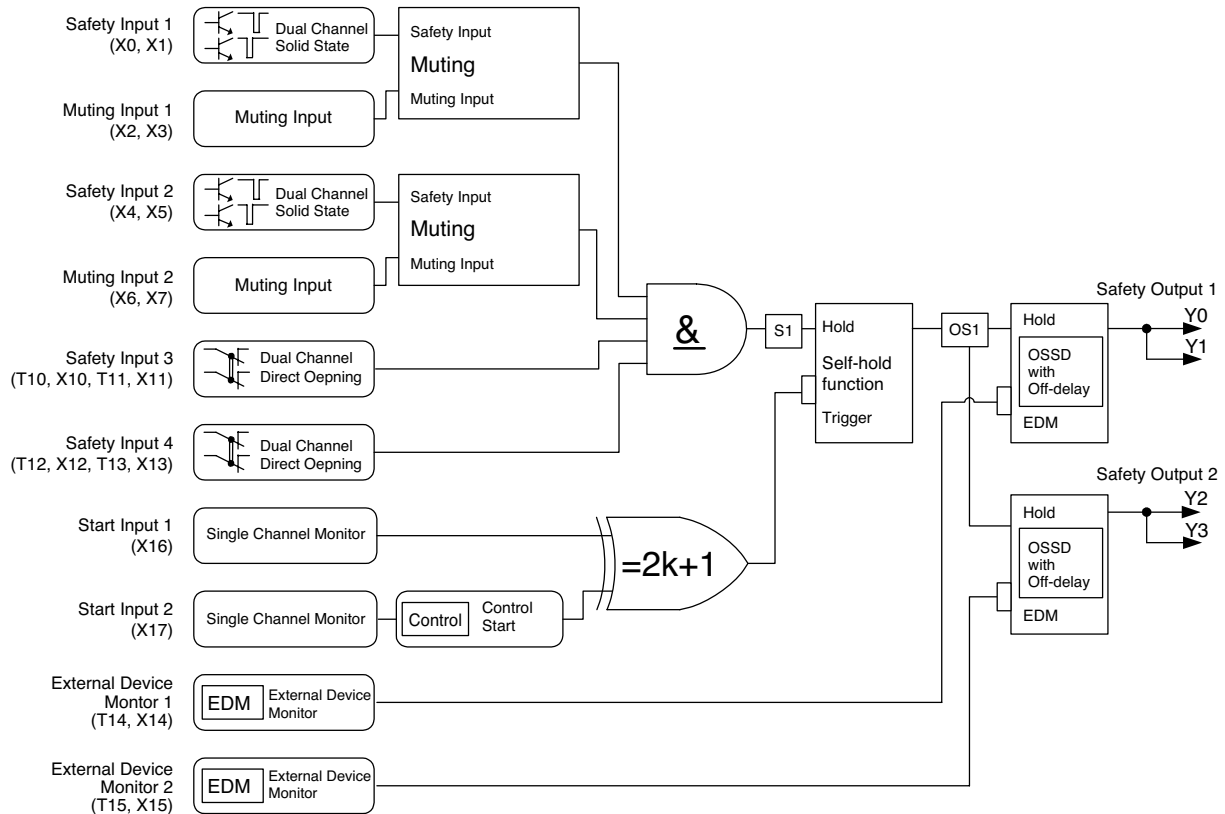

### • Monitor Output for Safety Input

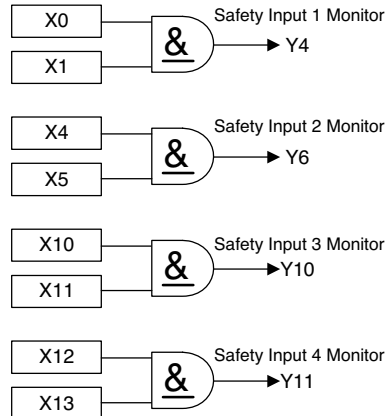

### • Monitor Output for Safety Output

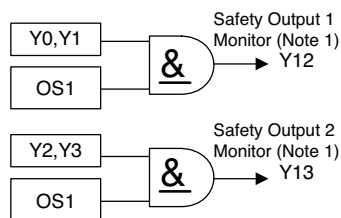

Note 1: Safety output 1 monitor and safety output 2 monitor turn off immediately independent of off-delay time.

### • Muting Lamp Output (Note 2)

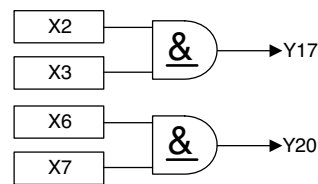

Note 2: The muting lamp output is turned on when the safety function of the safety input is temporarily suppressed. Even if the muting input is on, the muting lamp output is not turned on when the muting watch time is exceeded or the corresponding safety input (muting input 1: safety input 1) is off.

### • Monitor Output for Muting Input

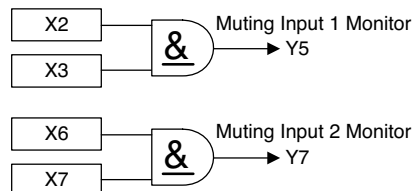

## • Logic 4 Wiring Example

When connecting two light curtains (PNP), four muting sensors (PNP), one emergency stop switch, and one interlock switch

- S1, S4: Light curtain (PNP type)
- S2, S3, S5, S6: Muting sensor (PNP type)
- S7: Emergency stop switch
- S8: Interlock switch
- S9: Start switch
- K1 to K4: Safety contactor
- L1, L2: Muting lamp
- M1, M2: Motor

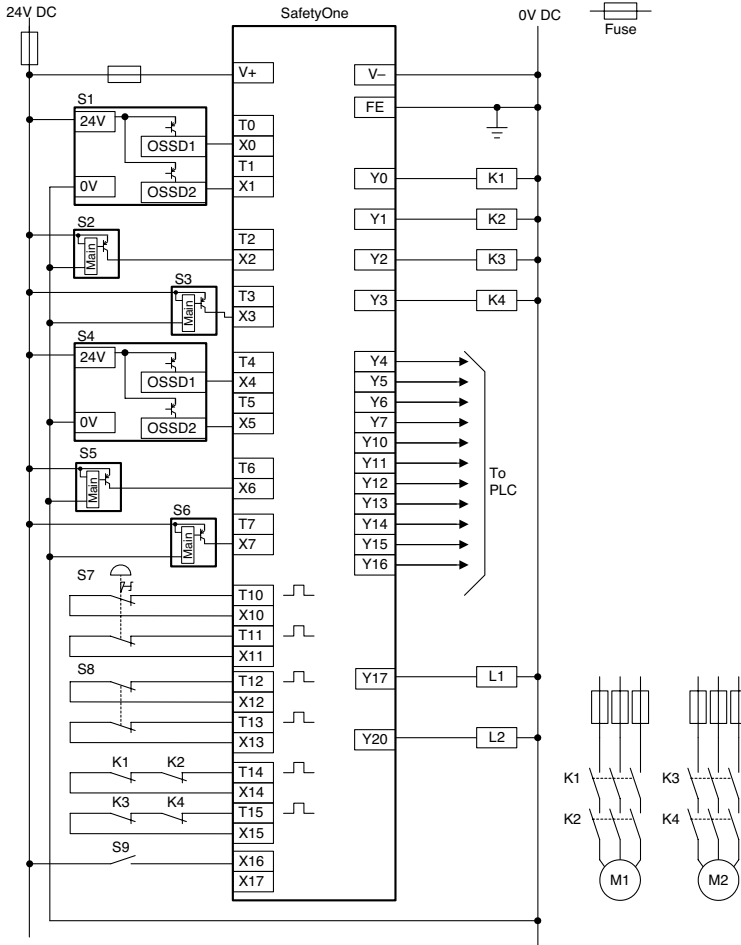

### Safety components used in this system

- Emergency stop switch: XA1E, XW1E, XN1E, HA1B, HA1E, HW1B, HW1E
- Interlock switch with solenoid (spring lock type): HS6E, HS5E, HS1E
- Light curtain (PNP type): SE4B
- Muting sensor (PNP type): SA1E
- Muting lamp: HW1P-5Q7
- Selector switch
- Non-contact safety switch (2NO type): HS7A
- Interlock switch: HS6B, HS5B

### When not using the start switch (auto start)

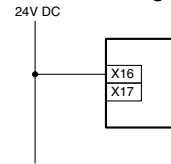

### When not detecting the welding of start switch (manual start)

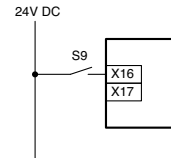

### When detecting the welding of start switch (control start)

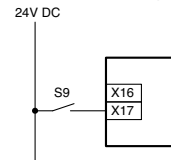

### When connecting multiple emergency stop switches in series

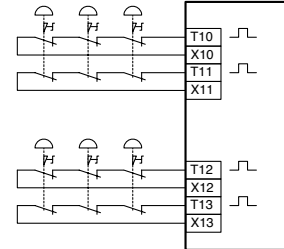

Note: Safety performance depends on the system configuration.

### When not using some safety inputs

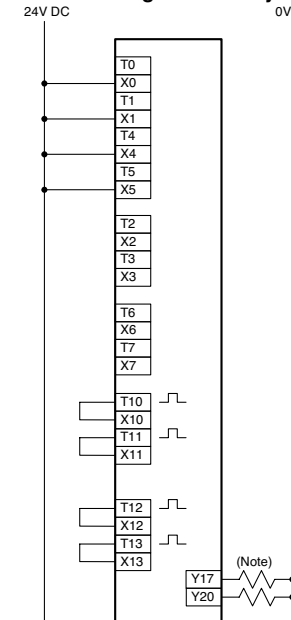

Note: In logic 4, wire disconnection or no-connection of the lamp connected to the muting lamp output terminals (Y17, Y20) is detected. When not using the muting function, connect resistors to these terminals. When resistors are not connected, the SafetyOne detects errors and locks out the circuit.

## • Logic 4 Time Chart

### When using manual start input X16

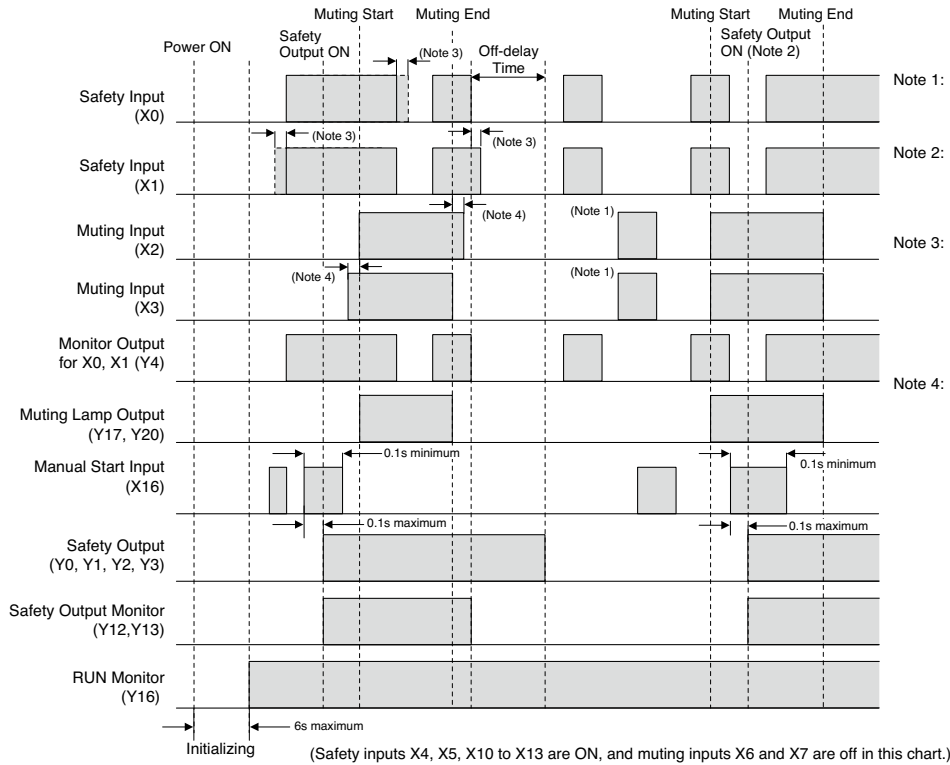

### When using control start input X17

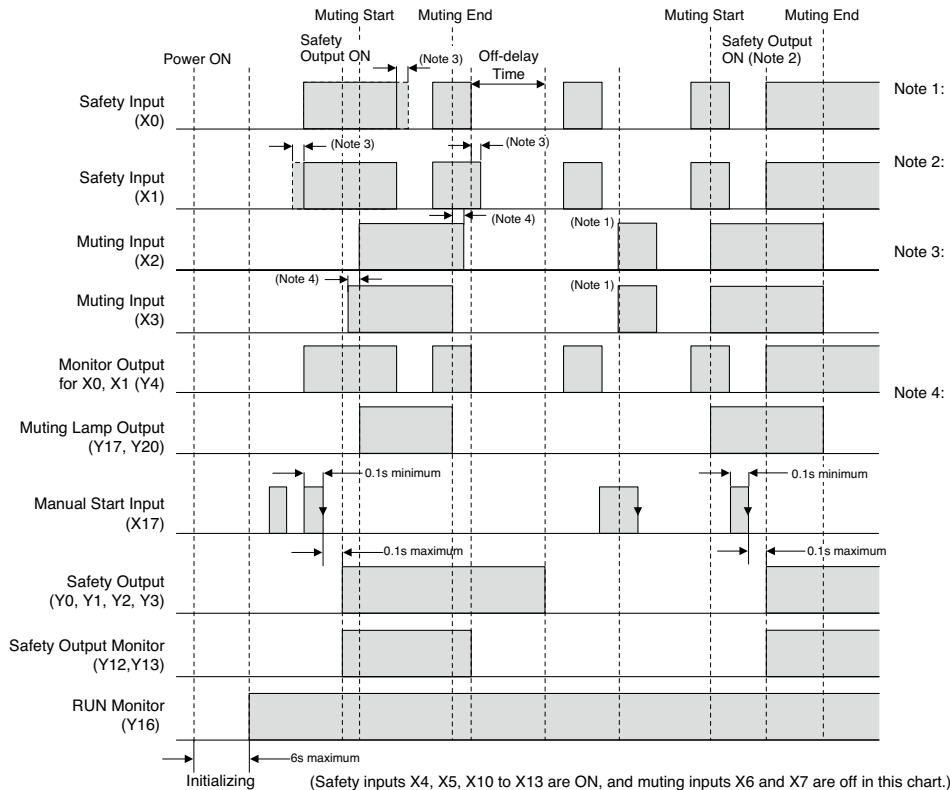

## Logic 5

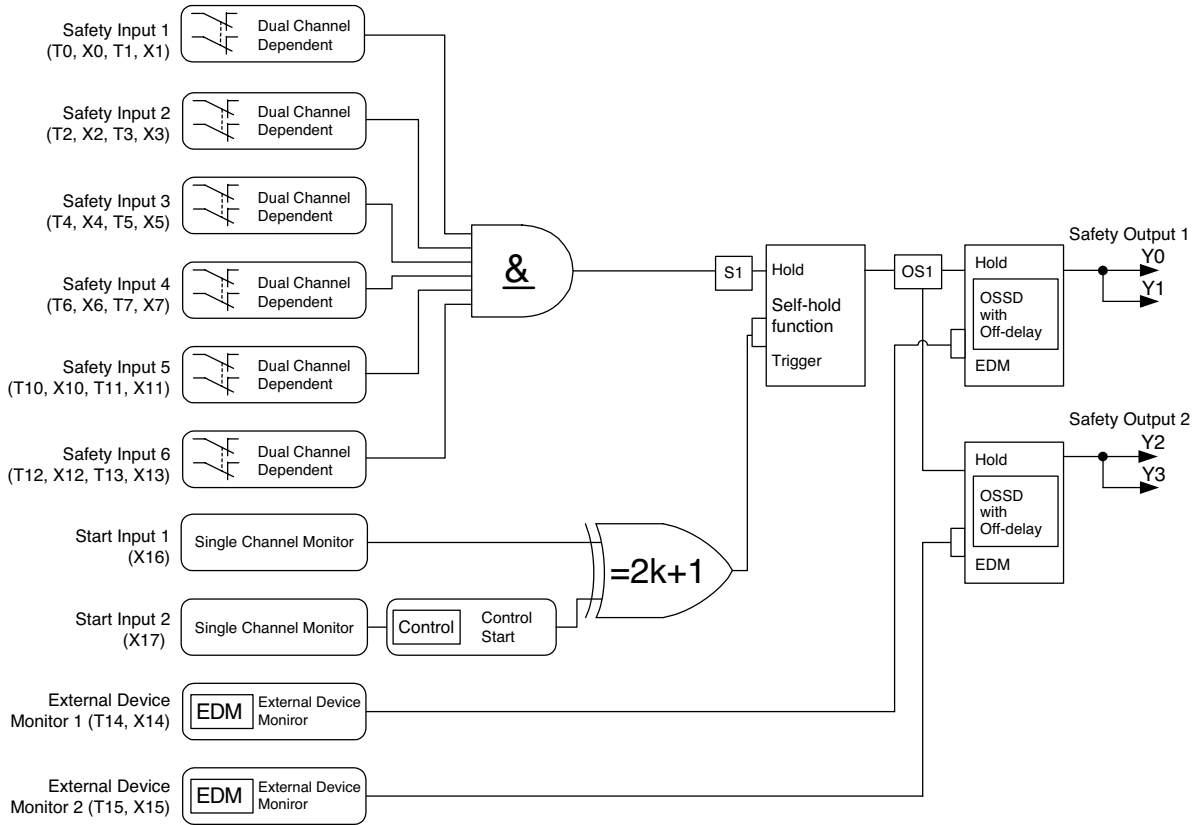

### • Monitor Output for Safety Input

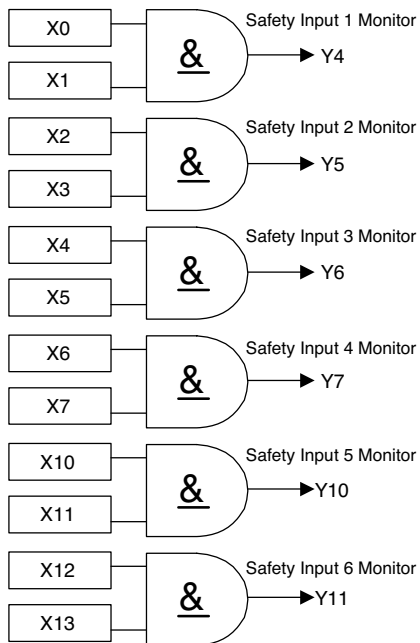

### • Monitor Output for Safety Output

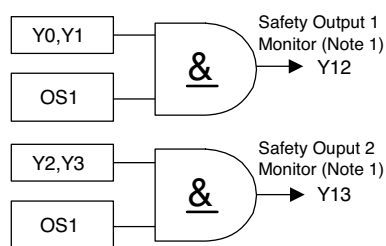

Note 1: Safety output 1 monitor and safety output 2 monitor turn off immediately independent of off-delay time.

### • Solenoid Output (Note 2)

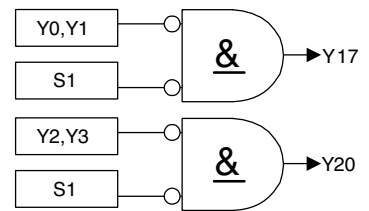

Note 2: In Run status, the solenoid output turns on when the safety output is off and one or more corresponding safety inputs are off. When all corresponding safety inputs are on, the solenoid output is turned off even when the start input is off.

## Logic 5 Wiring Example

When connecting two emergency stop switches, two interlock switches, and two interlock switches with solenoid (spring lock type)

- S1, S2: Emergency stop switch
- S3, S4: Interlock switch
- S5, S6: Interlock switch with solenoid (spring lock type)
- S7: Start switch
- K1 to K4: Safety contactor
- M1, M2: Motor
- S8, S9: Solenoid control switch  
(Pressing the solenoid control switches after closing the guard door, contacts 41-42 and 51-52 of S5 and S6 turn on, allowing the SafetyOne to restart.)

### Safety components used in this system

- Emergency stop switch: XA1E, XW1E, XN1E, HA1B, HA1E, HW1B, HW1E
- Interlock switch with solenoid (spring lock type): HS6E
- Non-contact safety switch (2NO): HS7A
- Interlock switch: HS6B, HS5B

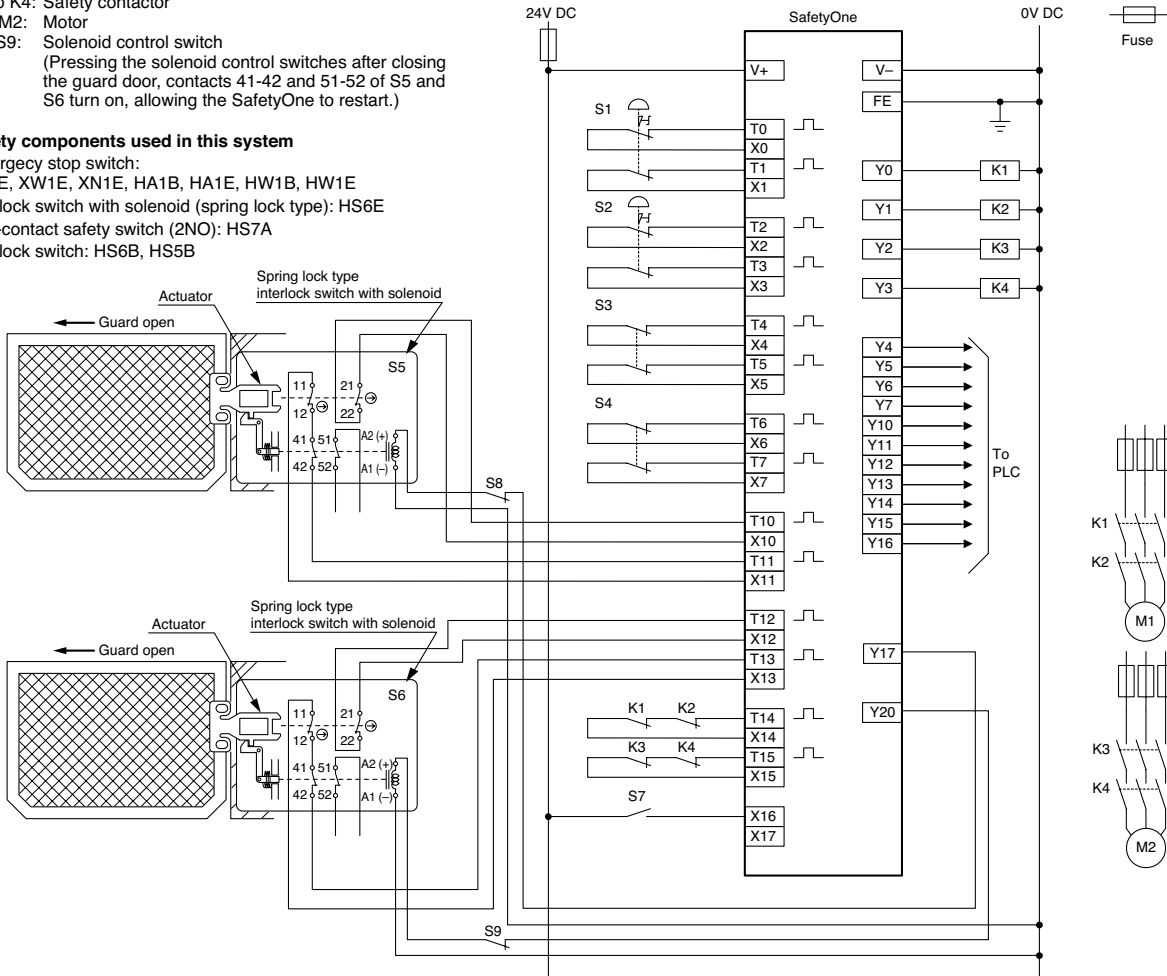

When not using the start switch (auto start)

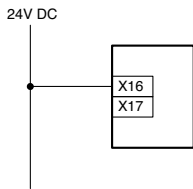

When not detecting the welding of start switch (manual start)

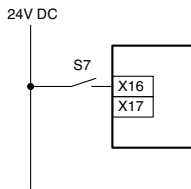

When detecting the welding of start switch (control start)

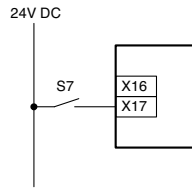

When connecting multiple emergency stop switches in series

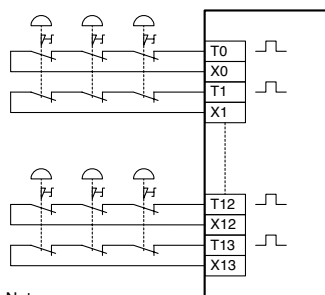

Note:  
Safety performance depends on the system configuration.

When not using some safety inputs

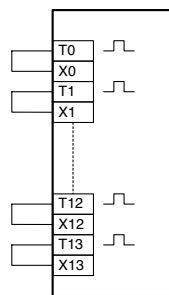



• Logic 5 Time Chart

**When using manual start input X16**

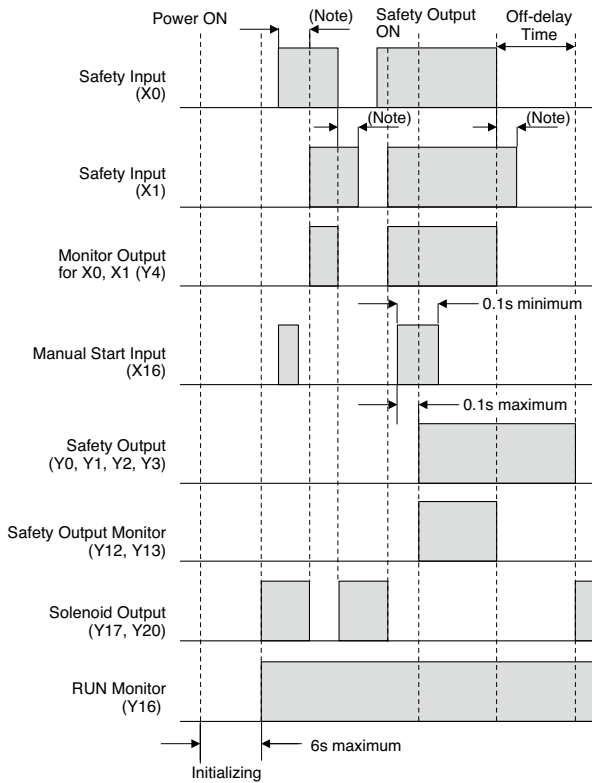

Note: The detection time of input monitor error is infinite.

**When using control start input X17**

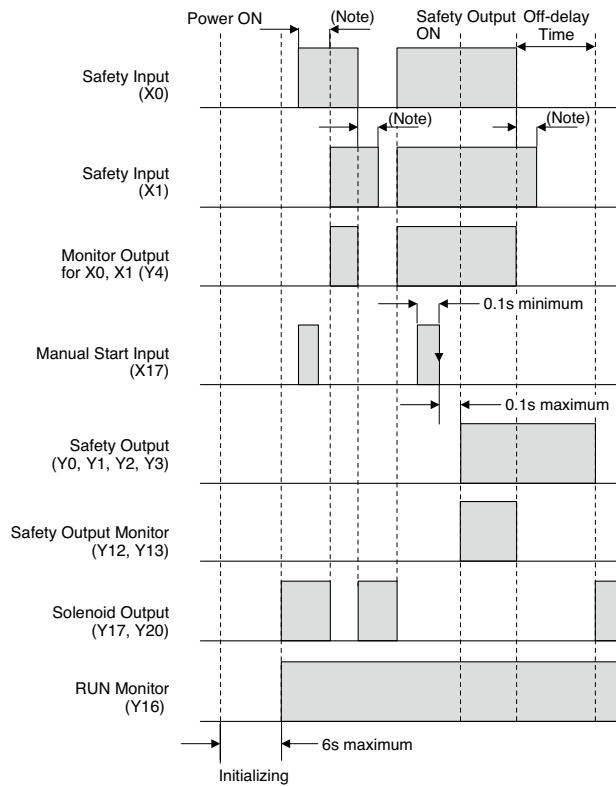

(Safety inputs X2 to X13 are ON in this chart.)

## Logic 6

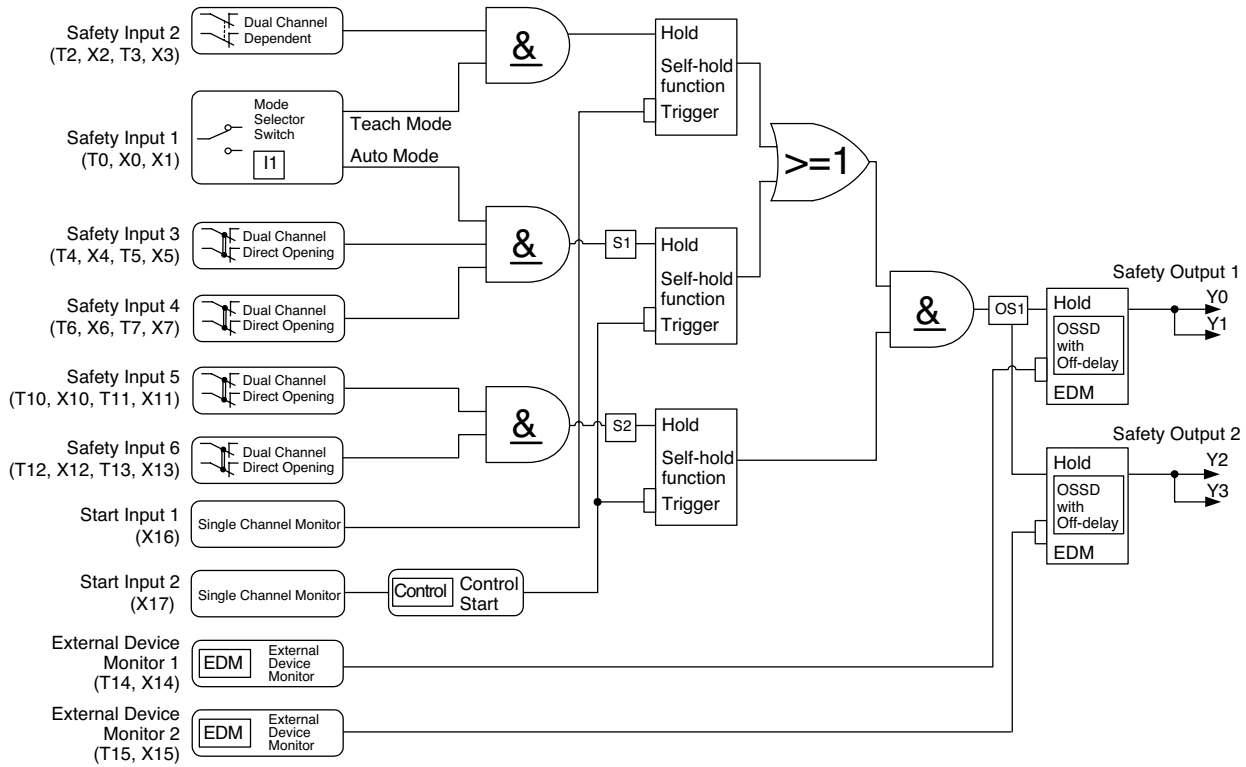

### • Monitor Output for Safety Input (Note 1)

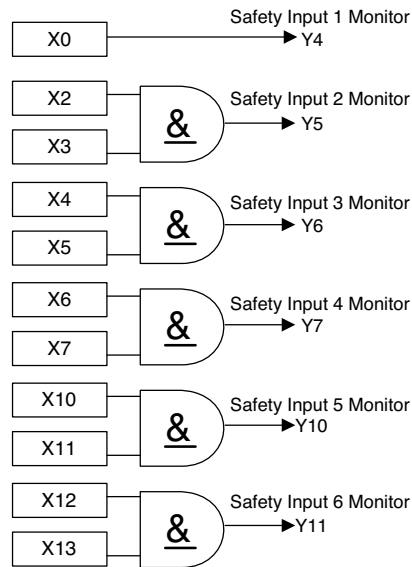

Note 1: Safety output 1 monitor is turned off when safety input 1 is set to auto mode.

### • Monitor Output for Safety Output (Note 2)

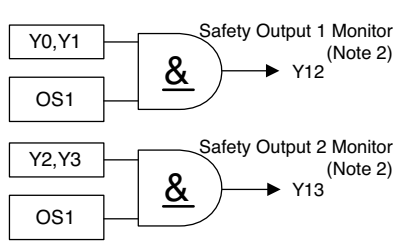

Note 2: Safety output 1 monitor and safety output 2 monitor turn off immediately independent of off-delay time.

### • Solenoid Output

#### Auto Mode (Note 3)

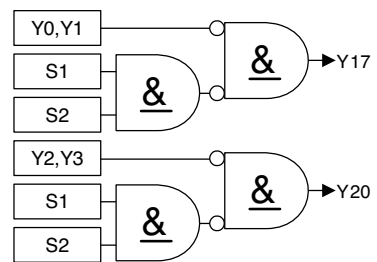

Note 3: Auto mode  
In Run state, the solenoid output turns on when the safety output is off and one or more corresponding safety inputs are off. When all corresponding safety inputs (except safety input 2) are on, the solenoid output is turned off even when the start input is off.

#### Teach Mode (Note 4)

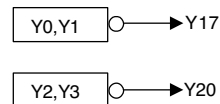

Note 4: Teach mode  
In Run state, the solenoid output turns on when the safety output is off.

## • Logic 6 Wiring Example

When connecting an enabling switch (2-contact), a selector switch, two emergency stop switches, and two interlock switches with solenoid (spring lock type)

- S1: Selector switch
  - S2: Enabling switch
  - S3, S4: Interlock switch with solenoid (spring lock type)
  - S5, S6: Emergency stop switch
  - S7, S8: Start switch
  - K1 to K4: Safety contactor
  - M1, M2: Motor
  - S9, S10: Solenoid control switch
- (Pressing the solenoid control switch after closing the guard door, contacts 41-42 and 51-52 of S3 and S4 turn on, allowing the SafetyOne to restart.)

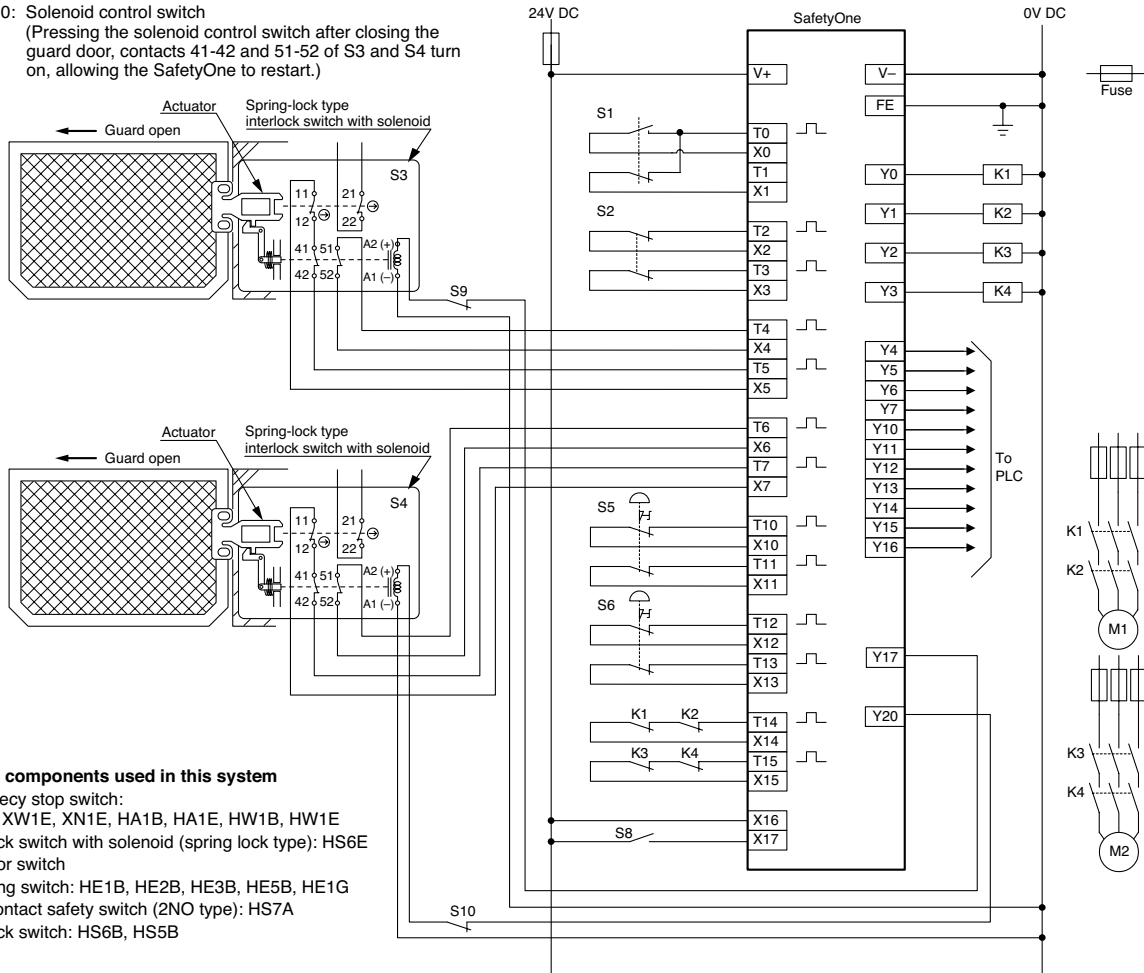

### Safety components used in this system

- Emergency stop switch: XA1E, XW1E, XN1E, HA1B, HA1E, HW1B, HW1E
- Interlock switch with solenoid (spring lock type): HS6E
- Selector switch
- Enabling switch: HE1B, HE2B, HE3B, HE5B, HE1G
- Non-contact safety switch (2NO type): HS7A
- Interlock switch: HS6B, HS5B

### When not using the start switch in teach mode (auto start)

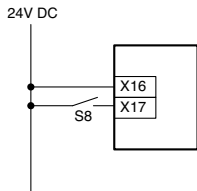

### When not detecting the welding of start switch in teach mode (manual start)

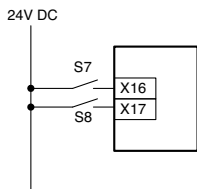

### When connecting multiple emergency stop switches in series

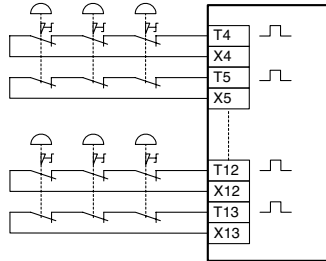

Note:  
Safety performance depends on the system configuration.

### When not using some safety inputs

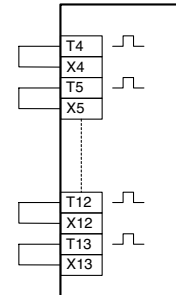

## • Logic 6 Time Chart

### Teach Mode

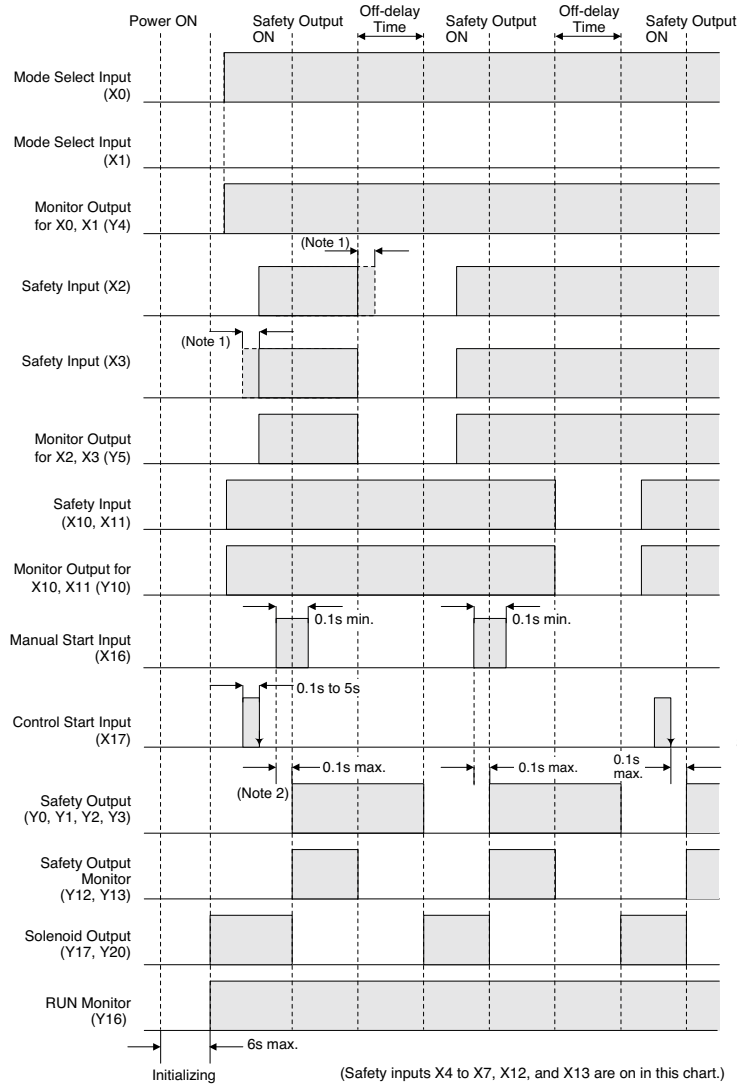

### Auto Mode

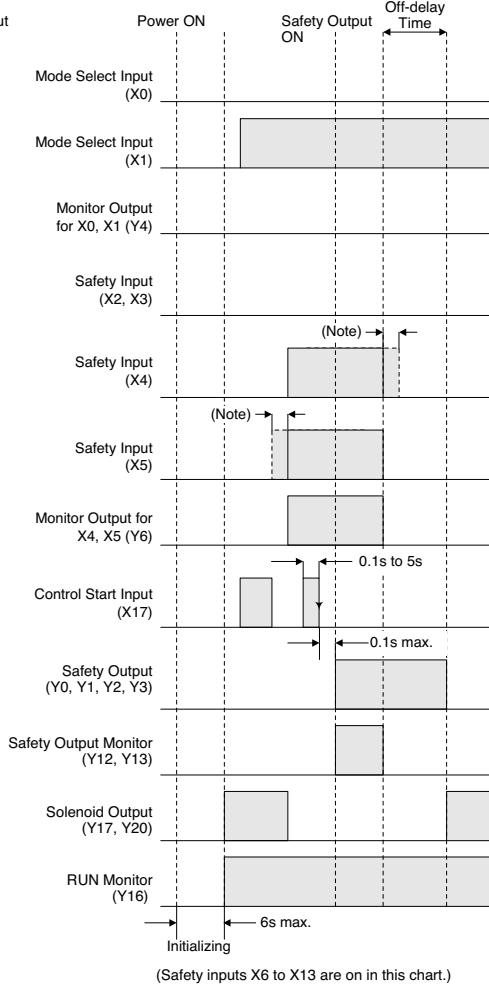

Note: When the input time difference is 0.5s or more, input monitor error is detected.

## Logic 7

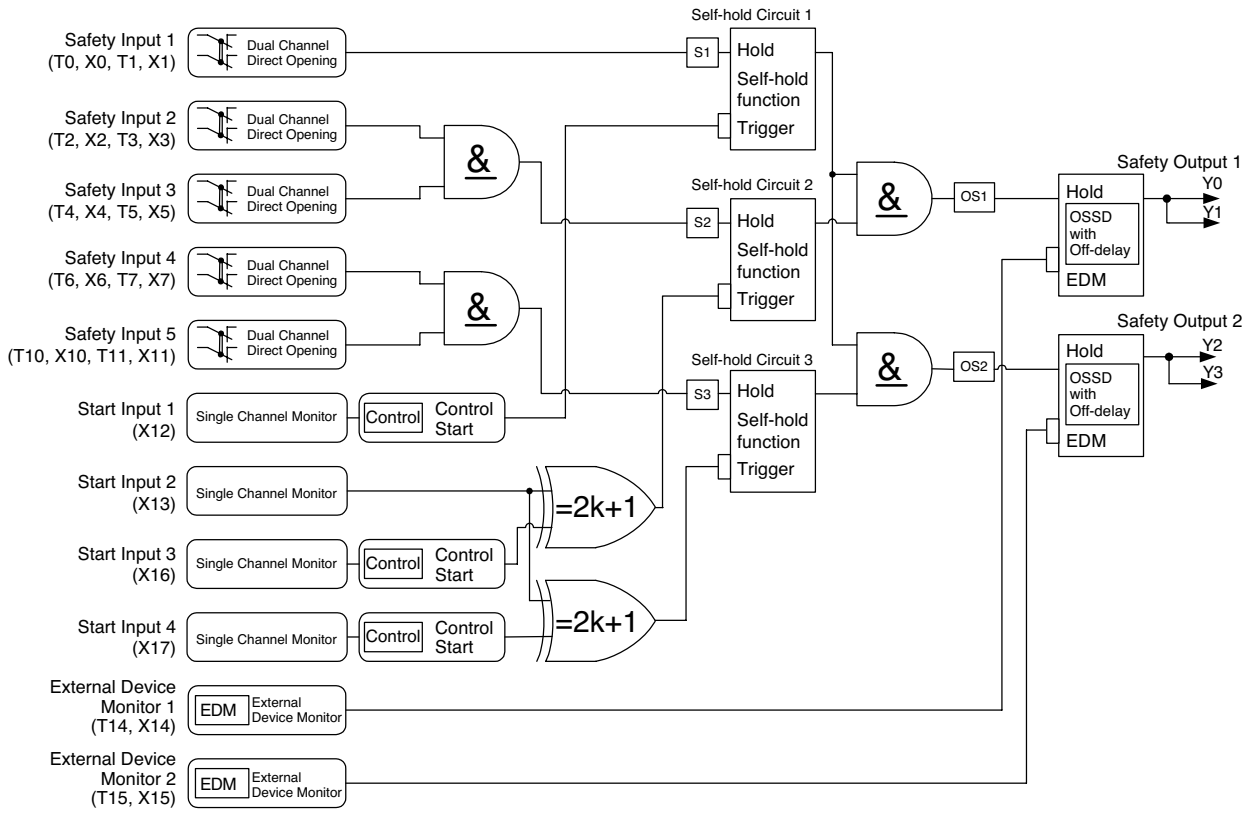

### • Monitor Output for Safety Input

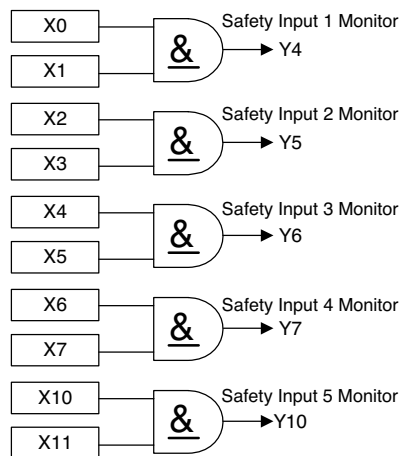

### • Monitor Output for Safety Output

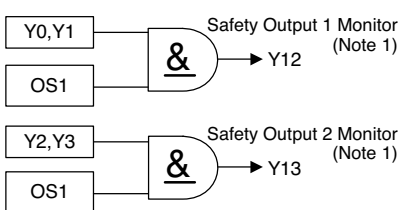

Note 1: Safety output 1 monitor and safety output 2 monitor turn off immediately independent of off-delay time.

### • Solenoid Output (Note 2)

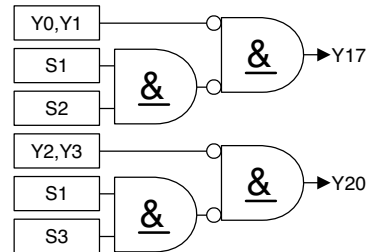

Note 2: In Run state, the solenoid output turns on when the safety output is off and one or more corresponding safety inputs are off. When all corresponding safety inputs are on, the solenoid output is turned off even when the start input is off.



## Logic 7 Wiring Example

### When connecting three emergency stop switches and two interlock switches with solenoid (spring lock type)

- S1, S2, S4: Emergency stop switch
  - S3, S5: Interlock switch with solenoid (spring lock type)
  - S6, S7, S8: Start switch
  - K1 to K4: Safety contactor
  - M1, M2: Motor
  - S9, S10: Solenoid control switch
- (Pressing the solenoid control switches after closing the guard door, contacts 41-42 and 51-52 of S3 and S5 turn on, allowing the SafetyOne to restart.)

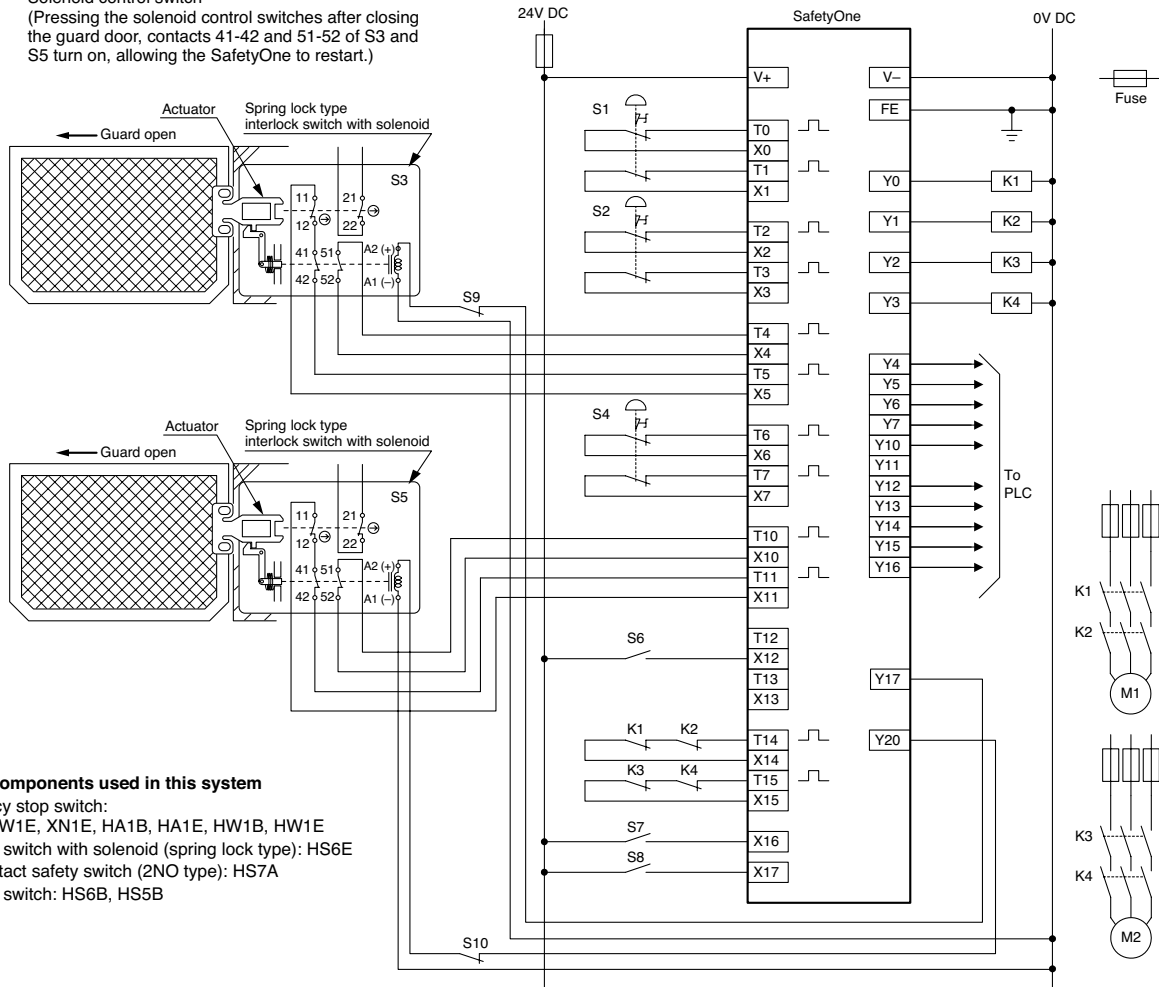

#### Safety components used in this system

- Emergency stop switch: XA1E, XW1E, XN1E, HA1B, HA1E, HW1B, HW1E
- Interlock switch with solenoid (spring lock type): HS6E
- Non-contact safety switch (2NO type): HS7A
- Interlock switch: HS6B, HS5B

#### When not using the start switch for the start input of partial stop (auto start)

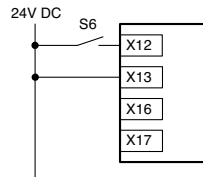

#### When not detecting the welding of start switch for partial stop (manual start)

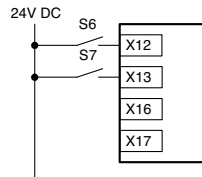

#### When detecting the welding of start switch for partial stop (control start)

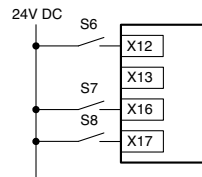

#### When connecting multiple emergency stop switches in series

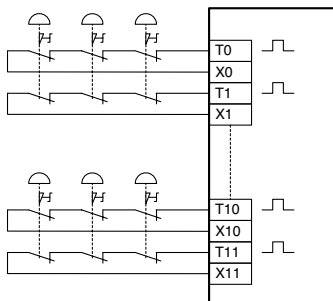

Note:  
Safety performance depends on the system configuration.

#### When not using some safety inputs

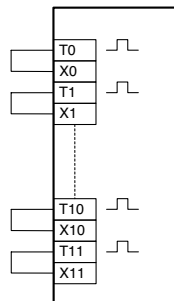

## • Logic 7 Time Chart

### When not detecting the welding of start switch on partial stop (manual start input X13 is used)

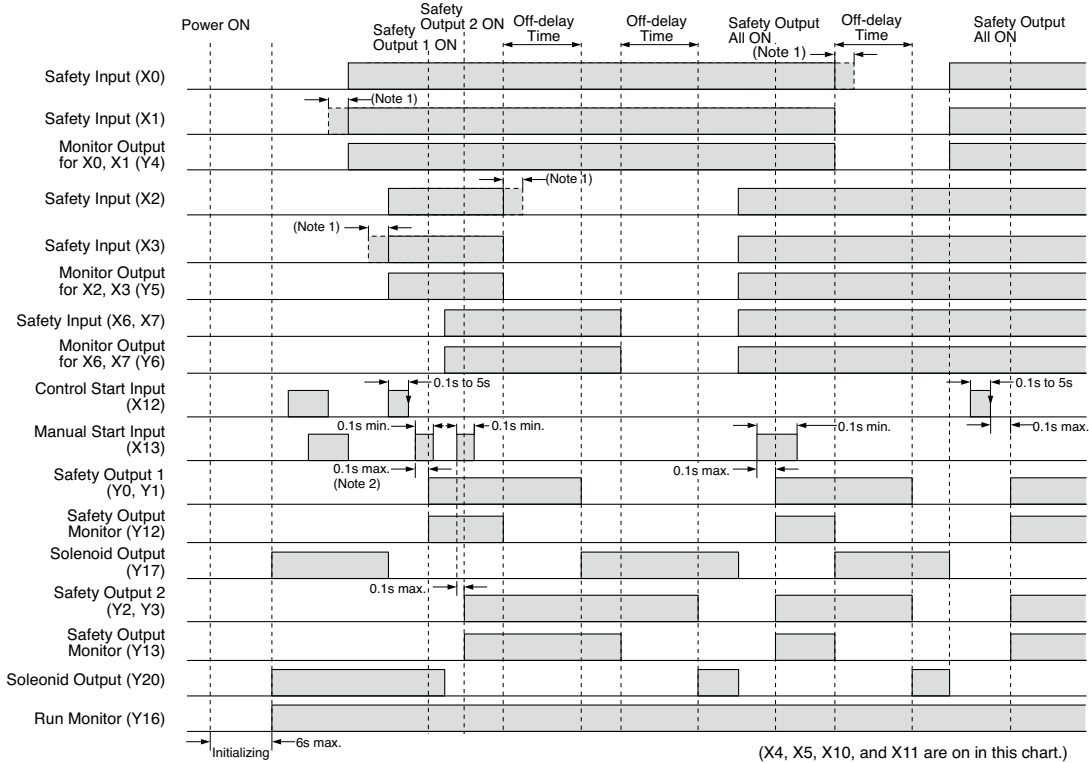

### When detecting the welding of start switch on partial stop (control start input X16 and X17 used)

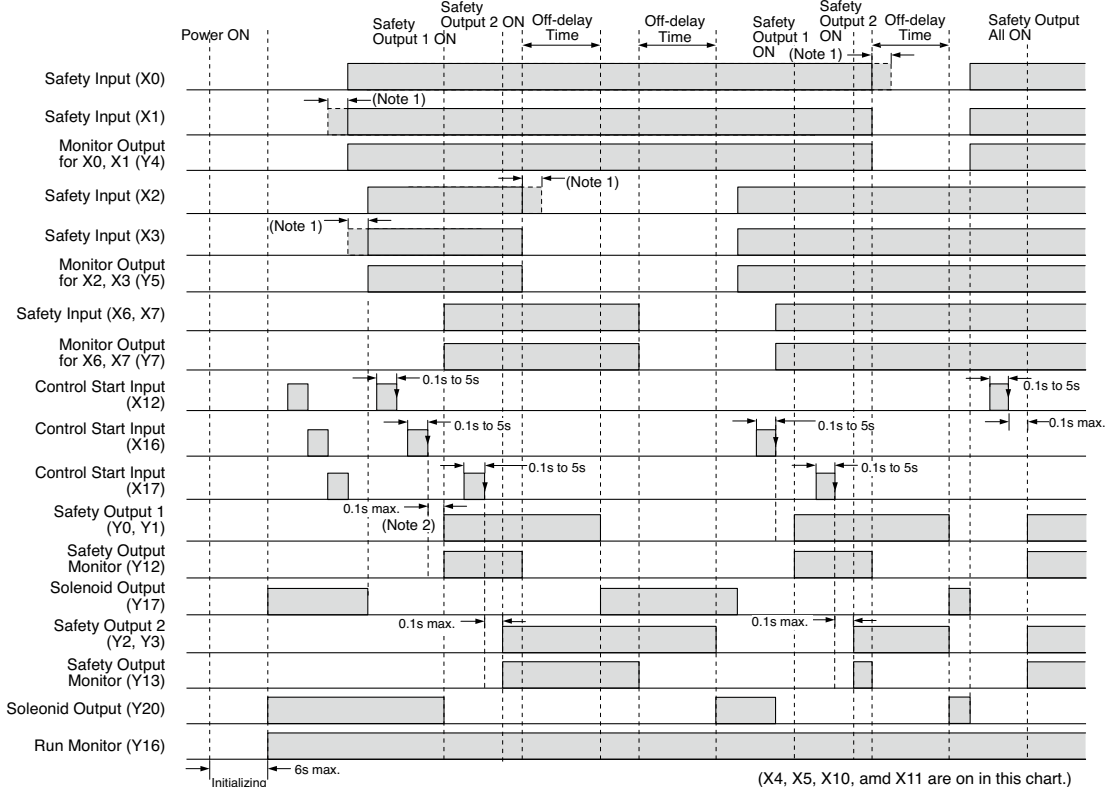

## Logic 8

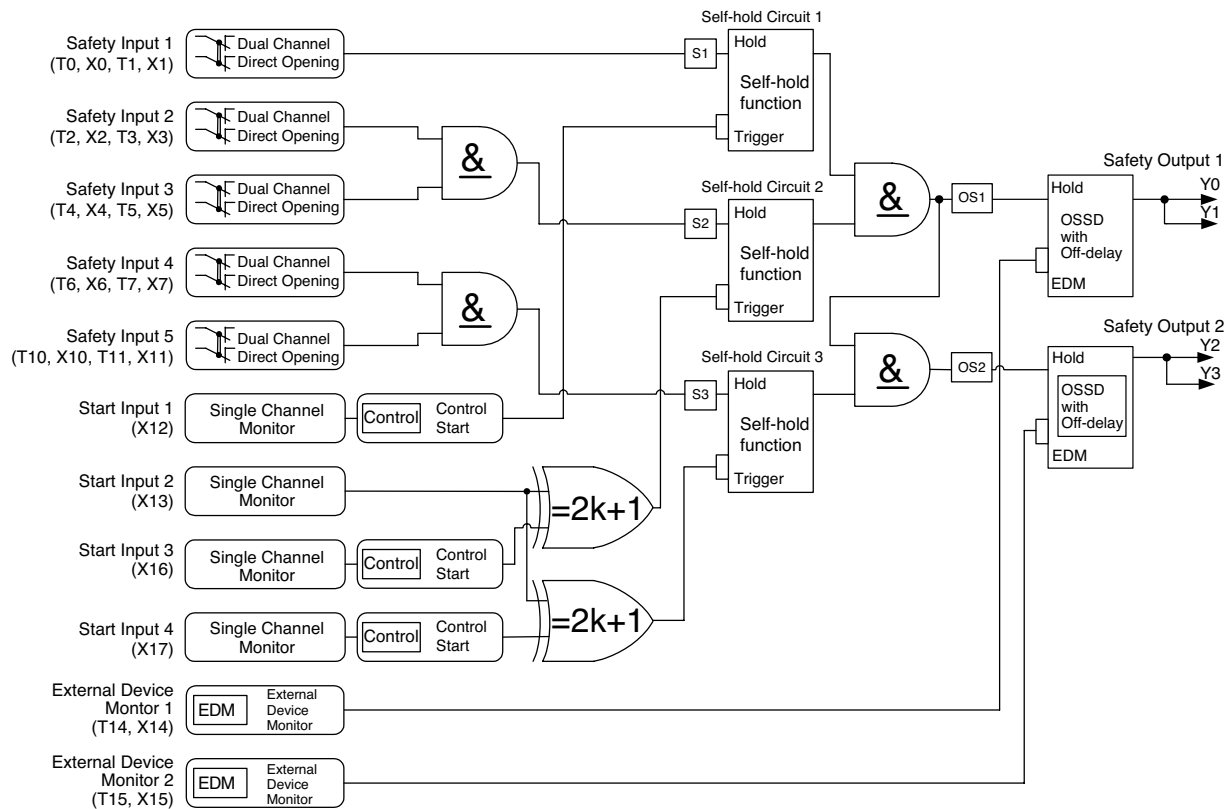

### • Monitor Output for Safety Input

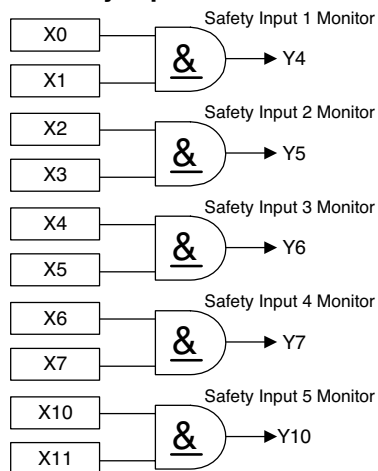

### • Monitor Output for Safety Output

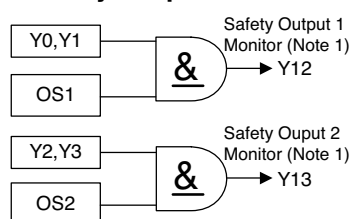

Note 1: Safety output 1 monitor and safety output 2 monitor turn off immediately independent of off-delay time.

### • Solenoid Output (Note 2)

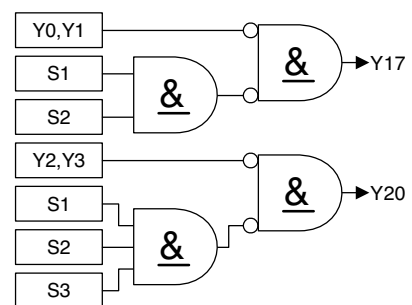

Note 2: In Run status, the solenoid output turns on when the safety output is off and one or more corresponding safety inputs are off. When all corresponding safety inputs are on, the solenoid output is turned off even when the start input is off.

## • Logic 8 Wiring Example

### When wiring three emergency stop switches and two interlock switches with solenoid (spring lock type)

- S1, S2, S4: Emergency stop switch
  - S3, S5: Interlock switch with solenoid (spring lock type)
  - S6, S7, S8: Start switch
  - K1 to K4: Safety contactor
  - M1, M2: Motor
  - S9, S10: Solenoid control switch
- (Pressing the solenoid control switches after closing the guard door, contacts 41-42 and 51-52 of S3 and S5 turn on, allowing the SafetyOne to restart.)

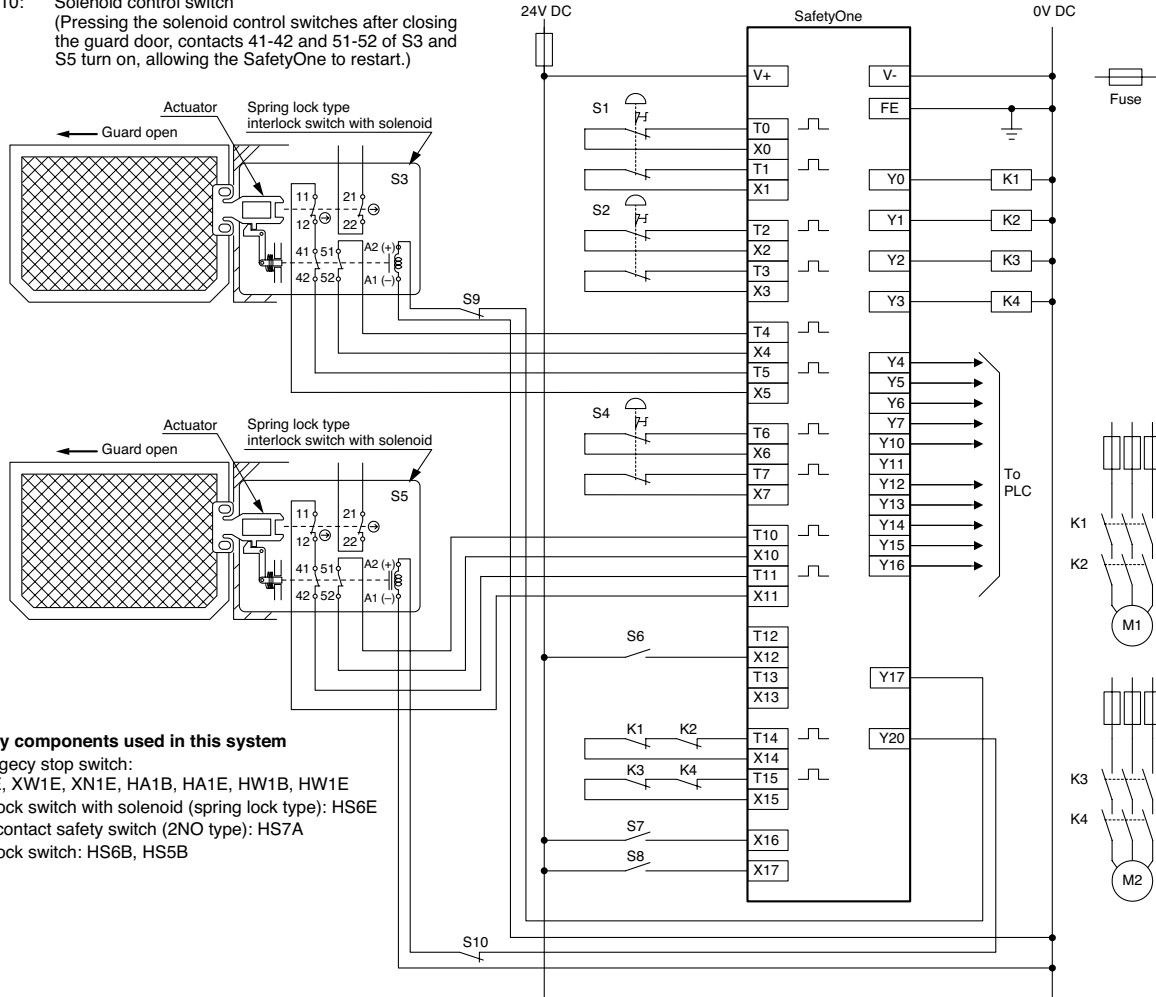

#### Safety components used in this system

- Emergency stop switch: XA1E, XW1E, XN1E, HA1B, HA1E, HW1B, HW1E
- Interlock switch with solenoid (spring lock type): HS6E
- Non-contact safety switch (2NO type): HS7A
- Interlock switch: HS6B, HS5B

#### When not using the start switch for partial stop (auto start)

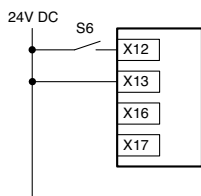

#### When not detecting the welding of start switch in partial stop (manual start)

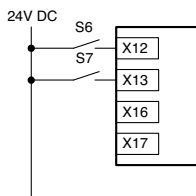

#### When detecting the welding of start switch in partial stop (control start)

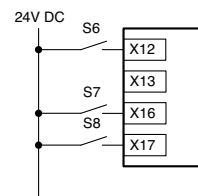

#### When connecting multiple emergency stop switches in series

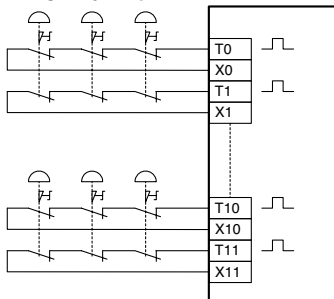

#### When not using some safety inputs

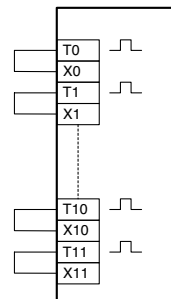

Note:  
Safety performance depends on the system configuration.

## • Logic 8 Time Chart

### When not detecting the welding of start switch on partial stop (manual start input X13 is used)

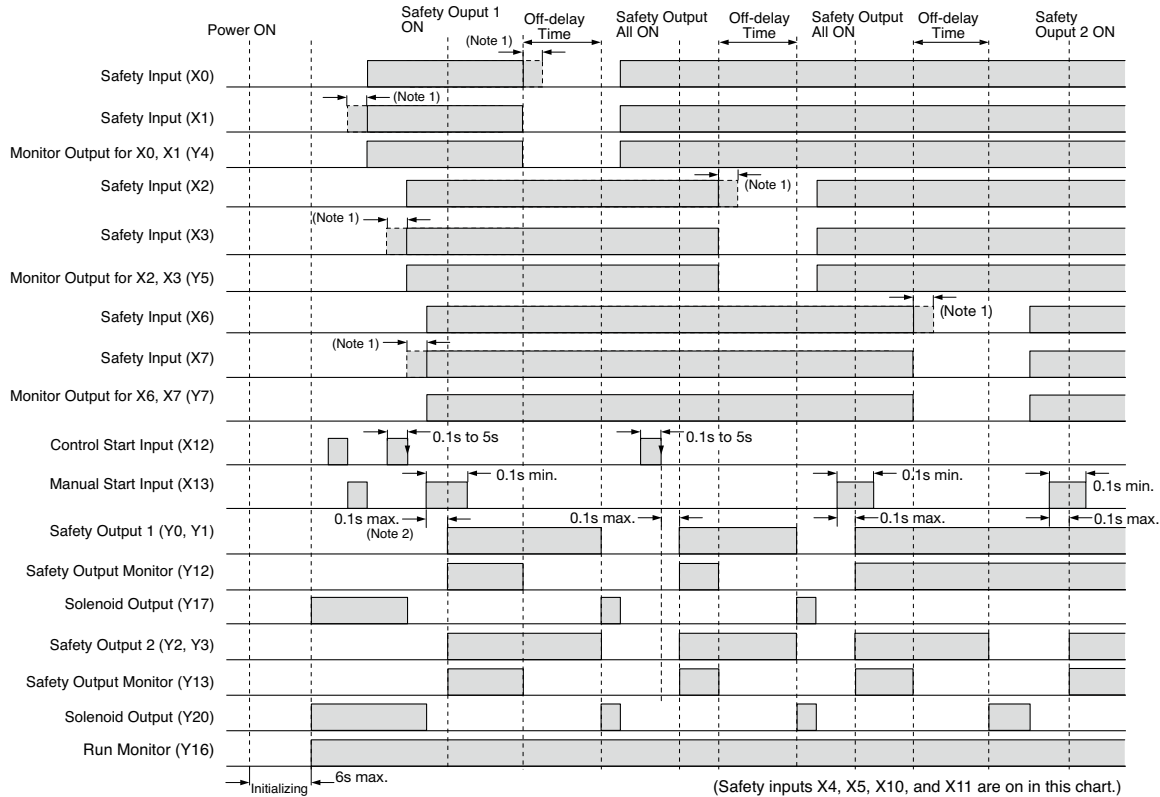

Note 1: When the input time difference at the dual channel safety input is 0.5s or more, input monitor error is detected.  
 Note 2: When the control start input (X12) is turned on before turning on the manual start input (X13).

### When detecting the welding of start switch on partial stop (control start inputs X16 and X17 are used)

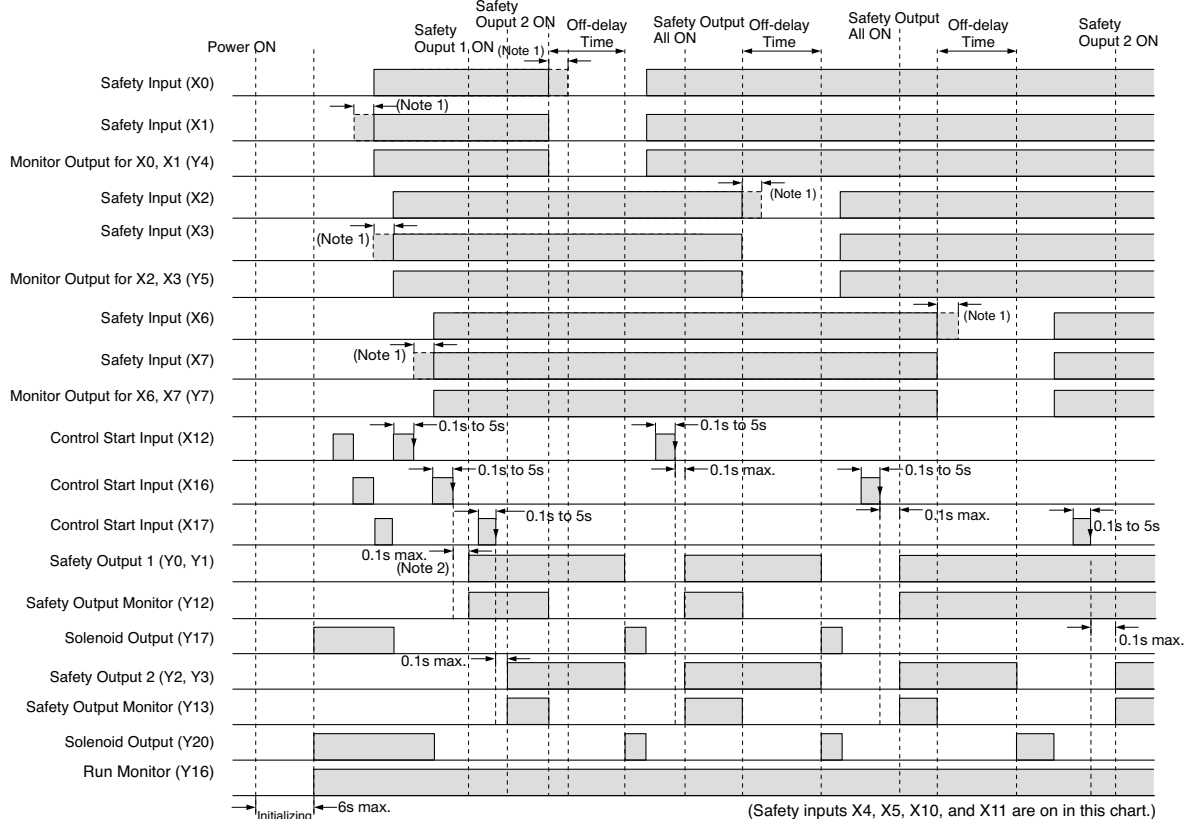

Note 1: When the input time difference at the dual channel safety input is 0.5s or more, input monitor error is detected.  
 Note 2: When the control start input (X12) is turned on before turning on the manual start input (X16).

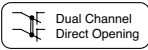
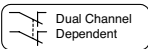
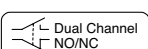
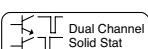
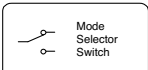
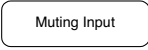
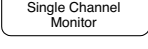
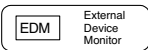
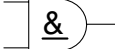
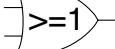
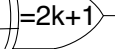
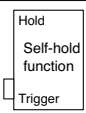
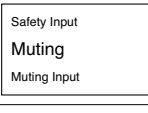
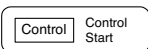
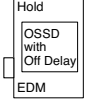

## Logic Functions

Type	Function	Symbol	Description
Input Function	Dual channel direct opening input		For connecting safety components with dual channel direct opening action mechanism, such as emergency stop switches and interlock switches.
	Dual channel dependent input		For connecting safety components with dual channel dependent action mechanism, such as enabling switches.
	Dual channel NO/NC Input		For connecting safety components with dual channel NO/NC mechanism, such as non-contact interlock switches.
	Dual channel solid state input		For connecting safety components with dual channel solid state output (PNP output), such as light curtains or safety laser scanners.
	Mode select input		For connecting components with mode select function, such as mode selector switches.
	Muting input		For connecting components such as muting sensors and limit switches.
	Monitor input		For connecting switches or sensors for start input.
	External device monitor input		For monitoring external devices controlled by the SafetyOne. External devices are diagnosed for errors by connecting a NC contact, such as contactor or safety relay.
Logic Operation Function	AND function		Logical multiplication (AND) of multiple inputs.
	OR function		Logical addition (OR) of multiple inputs.
	XOR function		Exclusive logical addition (XOR) of multiple inputs.
	Self-hold function		Self-holding of input.
	Muting function		Adds muting function to the connected safety components.
	Control start		Adds operation confirmation function to the connected start input devices.
Output Function	Safety output with timer		For controlling the safety output.

## Dimensions

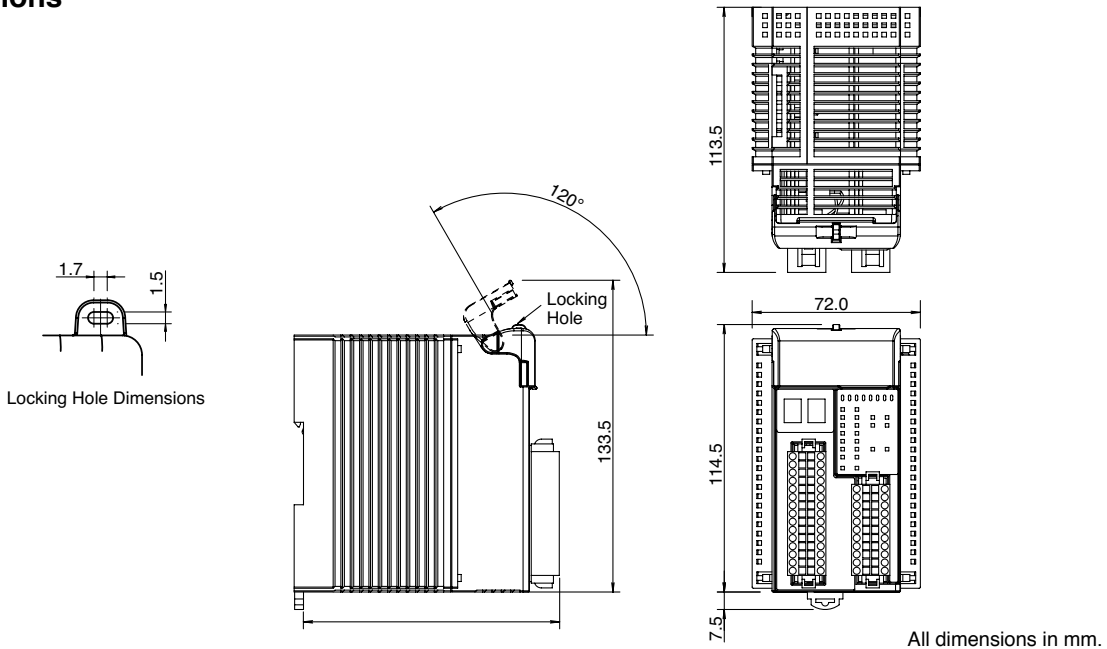

## Operating Instructions

### Installation Location

When installing the SafetyOne in an enclosure such as a control panel, make sure that the operating condition satisfies the specifications of the SafetyOne. Do not use the SafetyOne in an environment described below, or where the operating conditions exceed the limit of the SafetyOne. Otherwise electric shock, fire hazard, damage, or malfunction will be caused.

- Near inductive device or heat source
- Where excessive dust, dirt, salt, or iron powder is present
- Where the SafetyOne is exposed to vibration or shock

For maintenance and ventilation, provide space around the SafetyOne as shown in the figure below, so that sufficient distance is kept from other components, heat source, or panel surface.

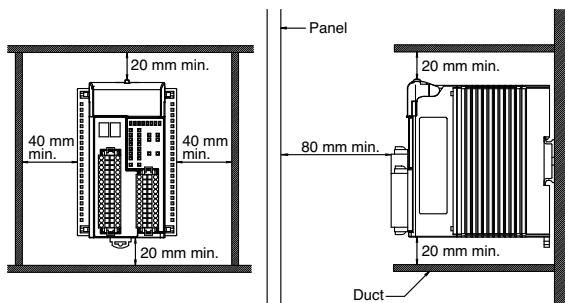

### Direction

Install the SafetyOne vertically as shown in Figure 1. Do not install in other directions (Figure 2).

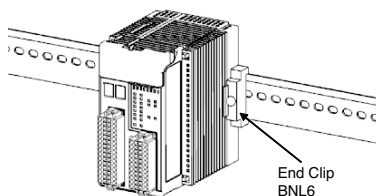

Figure 1. Correct Mounting Direction

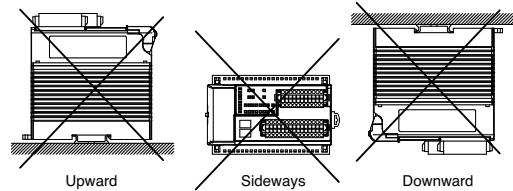

Figure 2. Incorrect Mounting Directions

### Installing on DIN Rails

Use 35mm-wide DIN rails for installing the SafetyOne. Applicable DIN rails: BAA1000 (IDEC)

#### Installing

1. Fasten the DIN rail to a panel using screws firmly.
2. Pull out the clamp from the SafetyOne module, and put the groove of the module on the DIN rail. Press the module towards the DIN rail and push in the clamp as shown below.
3. Use BNL6 end clips on both sides of the SafetyOne module to prevent from moving sideways.

#### Removal

1. Insert the tip of a flat screwdriver into the latch.
2. Pull down the latch until the latch clicks.
3. Pull out the SafetyOne lightly, and remove from the DIN rail.

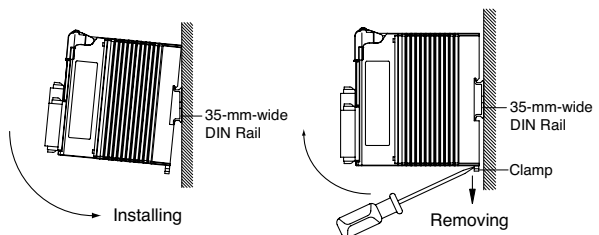

## Wiring

For wiring the SafetyOne, spring clamp (supplied with the SafetyOne) or crimp connector can be used. For crimp type connector, contact Tyco Electronics AMP.

Push the connector into the SafetyOne until the latches click. For removal, make sure to press down the latches completely before removing the connector, otherwise the connector and wires may be damaged.

## Applicable Wire and Ferrule Size (spring clamp type)

AWG#18 to 24 (recommended wire: UL1007)  
Strip length  $7.0 \pm 0.3$ mm.

When using a ferrule for wiring, select a ferrule which satisfies the terminal specifications shown below.

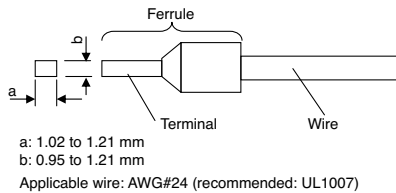

## Wiring to Spring Clamp Connector

When wiring to a connector, make sure that the connector is removed from the SafetyOne, otherwise the connector and the SafetyOne may be damaged. For wiring, use the connecting tool FS9Z-SD01. When rewiring, use the wire of the same type and size.

### • Wiring Using the Connecting Tool

1. Insert the connecting tool completely into the tool slot in the connector at an angle.



2. Insert a wire into the wire slot. When using a stranded wire, twist the wire beforehand so that the wire does not become loose.



3. While the wire is inserted, remove the connecting tool. Wiring is completed. Pull the wire lightly to confirm whether it is clamped securely.



4. To remove the wire, press down the spring using the connecting tool and pull out the wire.

### • Using a Screwdriver

When using a screwdriver for wiring, use a screwdriver of 2.4mm wide maximum at the tip. Pay extra attention when using a screwdriver, so that the connector is not damaged.

1. Insert the screwdriver into the tool slot on the connector at an angle, and press down so as to pry open the spring. Do not apply excessive force when inserting the screwdriver, otherwise the connector will be damaged. Do not insert the screwdriver into the wire slot.
2. While the screwdriver is inserted, insert a wire into the wire slot. When using a stranded wire, twist the wire beforehand so that the wire does not become loose.
3. While the wire is inserted remove the screwdriver. Wiring is completed. Pull the wire lightly to confirm whether it is clamped securely.
4. To remove the wire, press down the spring using the screwdriver and pull out the wire.

## Safety Precautions

1. Do not disassemble, repair, or modify the SafetyOne, otherwise the safety characteristics of the SafetyOne are impaired. Turn off the power to the SafetyOne before installation, removing, wiring, maintenance, or inspection of the SafetyOne. Failure to do so may cause electrical shocks or fire hazard.
2. Before operating the SafetyOne, read the instruction sheet and the user's manual carefully, and ensure that the environment conforms to the requirements of the SafetyOne specifications. If the SafetyOne is operated in an environment that exceeds the specifications of the SafetyOne, the safety characteristics of the SafetyOne are impaired.
3. The installation, wiring, configuration, and operation of the SafetyOne must be performed by safety experts only. Safety experts are personnel who have necessary qualifications authorizing them to perform designing, installation, operation, maintenance, and disposal of the SafetyOne. Persons without technical expertise must not use the SafetyOne.
4. The SafetyOne must be subjected to a regular test which proves that all functions of the SafetyOne satisfy the required standard.
5. Perform daily operation check on the SafetyOne.
6. Install the SafetyOne according to the instruction sheet and the user's manual. Improper installation may cause failure of the SafetyOne.
7. Do not use the monitor outputs or solenoid/lamp outputs as safety outputs, otherwise the system safety is impaired in case the SafetyOne or connected components fail.
8. Do not use the start input and the external device monitor input as safety inputs, otherwise the system safety is impaired in case the SafetyOne or connected components fail.
9. Use the SafetyOne in compliance with laws and regulations of the country or region where the SafetyOne is used.
10. Use safety inputs and safety outputs in circuit configurations which conform to safety requirements and applications.
11. Calculate the respective safety distances, while taking into consideration the response time of the SafetyOne and safety components connected to the SafetyOne.
12. Separate the SafetyOne from components and wires which do not satisfy Class 2 circuit requirements.
13. Safety performance differs depending on system configurations.
14. Use a power supply that meets the following required specifications completely:
  - Complies with the power supply rating of the SafetyOne.
  - The primary and secondary circuits are separated by double insulation or reinforced insulation.
  - Has the functionality equivalent of the control voltage and current of Class 2 circuit specified by UL508 or UL1310.
  - Complies with safety laws or regulations relating to electrical safety or EMC of the country where the SafetyOne is used.
15. Ground the V- line (0V DC) for ground diagnosis.
16. After setting a new configuration or modifying a configuration, check each input and output function.
17. Implement protective measure so that personal other than safety responsible persons operating the SafetyOne do not modify the configuration.
18. The SafetyOne is designed for installation within an enclosure. Do not install the SafetyOne outside an enclosure. Install the SafetyOne in enclosure of IP54 or higher protection.
19. Install the SafetyOne in environments specified in the catalog, instruction sheet, and user's manual. If the SafetyOne is used in places where the SafetyOne is subjected to high temperature, high humidity, condensation, corrosive gases, excessive vibra-

## Safety Precautions

- tions, or excessive shocks, failure such as electrical shocks, fire hazard, or malfunction may result.
20. Use the SafetyOne in an environment of pollution degree 2. (IEC 60664-1).
  21. Do not drop the SafetyOne during transportation, otherwise damage or malfunction may result.
  22. Prevent metal fragments and pieces of wire from dropping inside the SafetyOne housing. Put a cover on the SafetyOne during installation and wiring. Ingress of such fragments and chips may cause fire hazard, damage or malfunction.
  23. Install the SafetyOne so that there is adequate distance from the walls, heat generating devices or peripherals, taking into consideration spacing requirements for maintenance and ventilation.
  24. Install the SafetyOne on 35mm DIN rails with BNL6 end clips (sold separately) on both sides of the SafetyOne.
  25. Wire to the connectors with proper cables or ferrules.
  26. Ground the FE terminal to assure electromagnetic compatibility.
  27. Use a common 0V DC line when different power supplies are used for the SafetyOne and other components (ex. light curtain).
  28. Separate the input and output wiring from power lines.
  29. When overcurrent flows into output terminals, the protective function turns off the output. However, when overcurrent status lasts long, internal protective elements will fuse. To protect the internal elements, insert fuses of double the rated value to each terminal.
  30. Use the fuse compliant with IEC60127 requirements on the power line of the SafetyOne. (Required for equipment incorporating the SafetyOne for the use in Europe.)
  31. When disposing of the SafetyOne, do so according to the regulations of the country or region.

Specifications and other descriptions in this catalog are subject to change without notice.



## IDEC CORPORATION

7-31, Nishi-Miyahara 1-Chome, Yodogawa-ku, Osaka 532-8550, Japan  
Tel: +81-6-6398-2571, Fax: +81-6-6392-9731  
E-mail: products@idec.co.jp

**IDEC CORPORATION (USA)**  
1175 Elko Drive, Sunnyvale, CA 94089-2209, USA  
Tel: +1-408-747-0550 / (800) 262-IDEC (4332)  
Fax: +1-408-744-9055 / (800) 635-6246  
E-mail: opencontact@idec.com

**IDEC CANADA LIMITED**  
3155 Pepper Mill Court, Unit 4, Mississauga,  
Ontario, L5L 4X7, Canada  
Tel: +1-905-890-8561, Toll Free: (888) 317-4332  
Fax: +1-905-890-8562  
E-mail: sales@ca.idec.com

**IDEC AUSTRALIA PTY. LTD.**  
2/3 Macro Court, Rowville, Victoria 3178, Australia  
Tel: +61-3-9763-3244, Toll Free: 1800-68-4332  
Fax: +61-3-9763-3255  
E-mail: sales@au.idec.com

**IDEC ELECTRONICS LIMITED**  
Unit 2, Beechwood, Chineham Business Park,  
Basingstoke, Hampshire RG24 8WA, UK  
Tel: +44-1256-321000, Fax: +44-1256-327755  
E-mail: sales@uk.idec.com

**IDEC ELEKTROTECHNIK GmbH**  
Wendenstrasse 331, 20537 Hamburg, Germany  
Tel: +49-40-25 30 54 - 0, Fax: +49-40-25 30 54 - 24  
E-mail: service@idec.de

**IDEC (SHANGHAI) CORPORATION**  
Room 608-609, 6F, Gangtai Plaza, No. 700,  
Yan'an East Road, Shanghai 200001, PRC  
Tel: +86-21-5353-1000, Fax: +86-21-5353-1263  
E-mail: idec@cn.idec.com

**IDEC (BEIJING) CORPORATION**  
Room 211B, Tower B, The Grand Pacific Building,  
8A Guanghua Road, Chaoyang District,  
Beijing 100026, PRC  
Tel: +86-10-6581-6131, Fax: +86-10-6581-5119

**IDEC (SHENZHEN) CORPORATION**  
Unit AB-3B2, Tian Xiang Building, Tian'an Cyber Park,  
Fu Tian District, Shenzhen, Guang Dong 518040, PRC  
Tel: +86-755-8356-2977, Fax: +86-755-8356-2944

**IDEC IZUMI (H.K.) CO., LTD.**  
Units 11-15, Level 27, Tower 1,  
Millennium City 1, 388 Kwun Tong Road,  
Kwun Tong, Kowloon, Hong Kong  
Tel: +852-2803-8989, Fax: +852-2565-0171  
E-mail: info@hk.idec.com

**IDEC TAIWAN CORPORATION**  
8F-1, No. 79, Hsin Tai Wu Road, Sec. 1,  
Hsi-Chih, Taipei County, Taiwan  
Tel: +886-2-2698-3929, Fax: +886-2-2698-3931  
E-mail: service@tw.idec.com

**IDEC IZUMI ASIA PTE. LTD.**  
No. 31, Tannery Lane #05-01,  
HB Centre 2, Singapore 347788  
Tel: +65-6746-1155, Fax: +65-6844-5995  
E-mail: info@sg.idec.com

www.idec.com

Cat. No. EP1290-1 JANUARY 2009 PDF PRINTED IN JAPAN

(09/01/07)