

# SNAP PAC S-Series Controllers

## Features

- Up to 32 PAC Control flowcharts running simultaneously
- Two 10/100 Mbps Ethernet interfaces for host and I/O communication over standard Ethernet networks
- Wired+Wireless models add wireless LAN network interface as well
- RS-232 and RS-485 serial ports for connection to serial devices, including Opto 22 serial I/O units and PPP host communication.
- Multiple protocol support: TCP/IP, EtherNet/IP™, Modbus™/TCP, SNMP, SMTP, FTP, and OptoMMP™
- FTP server/client capability; includes file system and removable storage (2 GB microSD card)
- Use two identical models for controller redundancy

## Description

A SNAP PAC S-series programmable automation controller (PAC) provides powerful, real-time control and communication to meet your industrial control, monitoring, and data acquisition needs. As part of the Opto 22 SNAP PAC System, one of these compact, industrially hardened controllers can handle multiple control, automation, and data acquisition tasks involving digital and analog control, serial string handling, PID, and enterprise connectivity.

Connecting to Opto 22 serial- and Ethernet-based I/O systems, a SNAP PAC S-series controller runs control programs written in Opto 22's PAC Control™ software to monitor and control a wide range of devices and equipment. SNAP PAC S-series controllers are well suited to original equipment manufacturers (OEMs), system integrators, and end-users in process control, discrete manufacturing, or hybrid industries and applications.

A SNAP PAC S-series controller simultaneously runs up to 32 PAC Control flowcharts, although the PAC Control strategy can actually contain a much larger number of charts. The total number of flowcharts is limited only by the controller memory available for strategy storage.

## Ethernet Communication

All SNAP PAC S-series programmable automation controllers communicate over standard 10/100 Mbps Ethernet networks and can be attached to existing wired or wireless Ethernet networks. The controllers can also be used in an independent



**SNAP-PAC-S2 controller**

control network built with standard, off-the-shelf Ethernet hardware.

SNAP PAC S-series controllers include two 10/100 Mbps Ethernet interfaces for networking through an Ethernet switch to Ethernet hosts, as well as SNAP PAC brains and I/O, which provide local intelligence and the connections to digital and analog sensors and actuators as well as serial devices. These independent Ethernet ports have separate IP addresses that can be used with PAC Project™ Professional software to set up redundant network links to safeguard the availability and reliability of an I/O system, or to segment a control system's network from the enterprise LAN.

## Wired+Wireless Communication

**SNAP-PAC-S1-W** and **SNAP-PAC-S2-W** controllers add wireless capability to communications. In addition to the two wired network interfaces, these models have a wireless

## Part Numbers

Part	Description
SNAP-PAC-S1	Ethernet-based programmable automation controller with 2 Ethernet interfaces
SNAP-PAC-S1-FM	Ethernet-based programmable automation controller with 2 Ethernet interfaces, Factory Mutual approved
SNAP-PAC-S1-W	Wired+Wireless Ethernet-based PAC with 2 Ethernet interfaces and a wireless LAN interface
SNAP-PAC-S2	Ethernet-based programmable automation controller with 2 Ethernet interfaces and 4 serial ports
SNAP-PAC-S2-W	Wired+Wireless Ethernet-based PAC with 2 Ethernet interfaces, a wireless LAN interface, and 4 serial ports
SNAP-PSDIN	SNAP-PAC-S1 controller DIN-rail adapter
SNAP-S2DIN	SNAP-PAC-S2 controller DIN-rail adapter

network interface as well, so each PAC has a total of three separate IP addresses—two wired and one wireless. Wired+Wireless PACs can be used wirelessly or on a wired network, or both at once.

For flexibility in designing your wireless network, wireless communication includes support for 802.11a, b, and g standards. Wired+Wireless PACs can be used with a variety of wireless switches and other infrastructure hardware. For the best security, the 802.11i WPA2/AES standard is supported, while older WPA and WEP security standards are included for backwards compatibility.

Just like a laptop computer with a wireless connection, all functionality remains the same whether the Wired+Wireless PAC is used wirelessly or as part of a wired network. Supported protocols remain the same. Control programs run the same on both networks without reprogramming.

A Wired+Wireless S-series PAC can communicate with both wired and wireless SNAP PAC I/O units. (See [“I/O Units Supported” on page 3](#) for details.) If desired, the PAC can segment a wireless network from a wired one.

### Serial Communication

SNAP PAC S-series controllers provide RS-232 and RS-485 communication as follows:

The **SNAP-PAC-S1** and **SNAP-PAC-S1-FM** have two RS-232 serial ports that support general-purpose communication with serial devices; you can send and receive data from one or two serial devices connected directly to the controller. Port 0 can be connected to a modem using PPP (Point-to-Point Protocol). These controllers also have one pluggable two-wire RS-485 port that can be used for SNAP PAC or *mistic* serial I/O units. For additional serial interfaces, you can add one or more SNAP serial communication modules on SNAP PAC racks connected to the controller.

The **SNAP-PAC-S2** has four serial ports that can each be configured using PAC Manager as either RS-232 or RS-485 (2-wire or 4-wire). These serial ports can be used for I/O or for general-purpose serial communication. For the default configuration settings of these ports, see form 1592, the *SNAP PAC S-series User's Guide*.



## SNAP PAC S-Series Controllers

Configured as RS-232, the ports support remote serial device communication, and any one of the ports can be configured as a PPP modem connection for creating a TCP/IP network over PSTN (Public Switched Telephone Network) lines. Configured as RS-485, the serial ports connect to legacy Opto 22 *mistic*™ I/O units, including the serial B3000 brain and remote *mistic* bricks, and to SNAP PAC SB-series serial brains.

For additional serial host interfaces, you can add one or more SNAP serial communication modules on attached SNAP Ethernet-based I/O units.

### Controller Redundancy

Two identical SNAP PAC S-series controllers can be used to form a redundant system, where one controller actively runs the control program and the other is ready to take over immediately if the first one should fail.

Besides two identical PACs, a redundant system requires PAC Professional 9.0 or newer (see [“Software,”](#) below), and the SNAP PAC Redundancy Option Kit. For more information, see the *SNAP PAC Redundancy Option Kit Data Sheet* (form 1901) and the *SNAP PAC System Redundancy User's Guide* (form 1831), both available on our website.

### Backward Compatibility

S-series controllers have RS-485 serial interfaces for connecting to Opto 22's legacy *mistic* I/O units. The SNAP-PAC-S1 and SNAP-PAC-S1-FM have one RS-485 port, and the SNAP-PAC-S2 can be configured with up to four.

This connectivity with legacy serial-based I/O systems, combined with PAC Control Professional's ability to import control programs (or *strategies*) written in OptoControl™ software, provides a migration path to integrate older Opto 22 I/O systems into modern control hardware running on Ethernet networks.

For detailed information on updating control strategies and integrating legacy control hardware into modern systems, see the *FactoryFloor to PAC Project Migration Technical Note* (Opto 22 form 1692).

### Software

SNAP PAC controllers use Opto 22's **PAC Project** Microsoft® Windows®-compatible automation software for control programming, human-machine-interface (HMI) development, and OPC and database connectivity. Two versions of PAC Project are available:

# SNAP PAC S-Series Controllers

- **PAC Project Basic** includes PAC Control for developing control programs, PAC Display™ for creating operator interfaces, and PAC Manager™ configuration software.
- **PAC Project Professional** adds expanded versions of PAC Control and PAC Display, plus OptoOPCServer™ software for exchanging data with OPC 2.0-compliant client software applications and OptoDataLink™ for sharing SNAP PAC System data with ODBC-compliant databases.

Applications in the PAC Project software suite are described below:

**PAC Control Basic** is a graphical, flowchart-based programming tool for machine control and process applications. Using PAC Control, you create, download, and run strategies on a SNAP PAC controller. In addition to flowchart programming with subroutine capability, PAC Control includes a powerful, built-in scripting language based on C and other procedural languages. **PAC Control Professional** adds capabilities to import OptoControl strategies, to support *mistic* I/O units, and to use a SNAP PAC controller's independent Ethernet ports to segment communication links.

**PAC Display Basic** is an intuitive HMI package for building operator interfaces, or *projects*, for communicating with a SNAP PAC controller. PAC Display offers a full-featured HMI including alarming, trending, and a built-in library of 3,000 industrial automation graphics. **PAC Display Professional** adds the ability to import projects created in OptoDisplay, part of the Opto 22 FactoryFloor® software suite, and to use redundant communication links on SNAP PAC controllers. PAC Display Professional can also connect to Ethernet-based FactoryFloor controllers running OptoControl strategies or ioProject controllers running ioControl strategies.

**OptoOPCServer** (PAC Project Professional only) is a fast, efficient OPC 2.0-compliant server for communicating with many Opto 22 products, including SNAP PAC controllers running PAC Control strategies, SNAP PAC brains, SNAP Ultimate controller/brains, SNAP Ethernet and SNAP Simple brains, and Ethernet-based FactoryFloor controllers running OptoControl strategies.

Using OptoOPCServer, you can consolidate data from all these Opto 22 systems into the OPC client software of your choice, such as third-party HMI and data acquisition packages, and custom software applications you create with tools such as Visual C++®.

**OptoDataLink** (PAC Project Professional only) transparently provides multiple connections for data exchange with popular databases such as Microsoft SQL Server, Microsoft Access, and MySQL. OptoDataLink connects your SNAP PAC system with the tools used for making business decisions, bringing realtime, accurate data to decision makers.

**PAC Manager** is a utility application for assigning IP addresses to SNAP PAC controllers and brains, reading or changing basic controller configuration, upgrading firmware, and inspecting or testing controllers and I/O.

## Software Availability

PAC Project Basic is included with SNAP PAC controllers and is a free download from the Opto 22 website. PAC Project Professional is available for purchase. You can also separately purchase PAC Control Professional, PAC Display Professional, OptoOPCServer, and OptoDataLink as needed. For additional information, see the *PAC Project Data Sheet*, Opto 22 form 1699.

## I/O Units Supported

S-Series Controller	On a Wireless LAN	On a Wired Ethernet Network	On a Serial Network
SNAP-PAC-S1 SNAP-PAC-S1-FM SNAP-PAC-S2	---none---	SNAP-PAC-R1 SNAP-PAC-R1-FM SNAP-PAC-R2 SNAP-PAC-R2-FM SNAP-PAC-EB1 SNAP-PAC-EB1-FM	SNAP-PAC-SB1 SNAP-PAC-SB2 B3000* B3000-B* SNAP-BRS* B100* B200* G4D16R* G4D32RS* G4A8R*
SNAP-PAC-S1-W SNAP-PAC-S2-W	SNAP-PAC-R1-W SNAP-PAC-R2-W SNAP-PAC-EB1-W SNAP-PAC-EB2-W	SNAP-PAC-EB2 SNAP-PAC-EB2-FM SNAP-UP1-ADS* SNAP-B3000-ENET* SNAP-ENET-D64* SNAP-ENET-S64* SNAP-ENET-RTC*	
* Legacy I/O processors; not recommended for new development			

# SNAP PAC S-Series Controllers

## Technical Specifications

Specifications are continued on the following page.

Processor	266 MHz 32-bit ColdFire® 5475 with integrated floating-point unit (FPU)
Memory Total RAM Battery-backed RAM Flash	Wired+Wireless: 128 MB; other models 32 MB. (16 MB for PAC Control strategy) 8 MB 16 MB (7.5 MB available for PAC Control strategy; 4 MB available for file storage)
Removable storage	(Models manufactured November 2008 and later; requires firmware R8.4 or higher) MicroSD card slot: supports MicroSD card up to 2 GB maximum
Backup battery	SNAP-PAC-S1s with serial number 625654 or higher and all SNAP-PAC-S2s: Rechargeable (recharges whenever the brain has power), 1-year power-off data retention SNAP-PAC-S1s with serial number 625653 or lower: User-replaceable 3.6-volt TL 5242 /W lithium, 10-year minimum power-off data retention (replacement part number: G4BATT32)
Ethernet Communication (wired) to host and I/O	Two independent 10/100 Mbps Ethernet network interfaces (RJ-45 connectors). Each interface has a separate IP address (separate subnet).
Ethernet Communication (wireless)* Topologies Security  Frequency 802.11a Frequency 802.11b/g Transmit Power Antenna Connector Roaming	Wireless LAN interface with separate IP address.  Infrastructure, Ad-Hoc 802.11i: AES - Compatible with WPA2 Personal, TKIP - Compatible with WPA Personal, WEP. Note: TKIP/AES security is not supported in Ad-Hoc mode. 5.180–5.240 GHz, 5.745–5.825 GHz 2.412–2.472 GHz, 2.484 GHz 15 dBm maximum Reverse polarity SMA (RP-SMA or RSMA) Supported within an SSID (Service Set Identifier) only
Serial Communication  SNAP-PAC-S1 RS-232 serial  RS-485 serial   SNAP-PAC-S2	Two RS-232 serial ports (one DB-9 and one pluggable connector); one port has full handshaking. PPP is supported only on port 0. Buffer size: 512 bytes each for RX and TX. One RS-485 serial port (pluggable connector); two-wire RS-485; optional <i>mistic</i> signal interrupts. Range (serial multidrop): 32 stations maximum on a segment (including PC, controller, repeaters, and I/O units); up to 3000 ft (914 m) on a segment. Buffer size: 512 bytes each for RX and TX.  Four serial ports that can be used as general purpose ports or for serial I/O units; each port is software configurable as either RS-232 (Tx, Rx, COM, DTR, DCD, RTS, CTS) or as RS-485 (2-wire, 4-wire, optional termination, optional biasing); optional <i>mistic</i> signal interrupts. Buffer size: 512 bytes each for RX and TX.
I/O unit compatibility Ethernet-based I/O units  Serial-based I/O units	Opto 22 SNAP PAC R-series, SNAP PAC EB-series, SNAP SIO, SNAP EIO, and SNAP UIO brains SNAP PAC SB-series, Serial B3000, SNAP-BRS, B100/B200, <i>mistic</i> remote bricks (G4D16R, G4D32RS, G4A8R)
Power requirements	8–32 VDC $\pm$ 0.5, 11.3 VA maximum (SNAP-PAC-S1 controllers with serial numbers below 500,000 use 8–24 VDC)

## SNAP PAC S-Series Controllers

Operating temperature Storage temperature Humidity	0 °C to 60 °C -40 °C to 85 °C 0% to 95% relative humidity, non-condensing
Software PAC Project Basic  PAC Project Professional	Includes programming, HMI software, and configuration software; included with purchase of controller. PAC Project Basic plus OPC 2.0-compliant OPC server, OptoControl strategy and OptoDisplay project importing, support for serial <i>mistic</i> I/O units, and Ethernet link redundancy support.
Number of charts that can run simultaneously	32
Other features	Multiple protocol support including TCP/IP, FTP, SNMP v2.0c (with firmware 8.2a), Modbus/TCP, EtherNet/IP™, and OptoMMP™. Real-time clock FTP server/client with file system (in RAM and in removable storage) Ethernet link redundancy or network segmenting
Agency certifications	(-W models only) U.S., FCC Part 15 Subpart C; Canada, IC RSS-210 (-FM models only) Factory Mutual approved All models: CE, RoHS, DFARS
Warranty	30 months from date of manufacture

\* Requires a Wired+Wireless model (SNAP-PAC-S1-W or SNAP-PAC-S2-W)

# SNAP PAC S-Series Controllers

## System Architecture (continued)

### SNAP-PAC-S1 Controller and Serial-based I/O Units

The network shown in this diagram requires PAC Control Professional and PAC Display Professional.

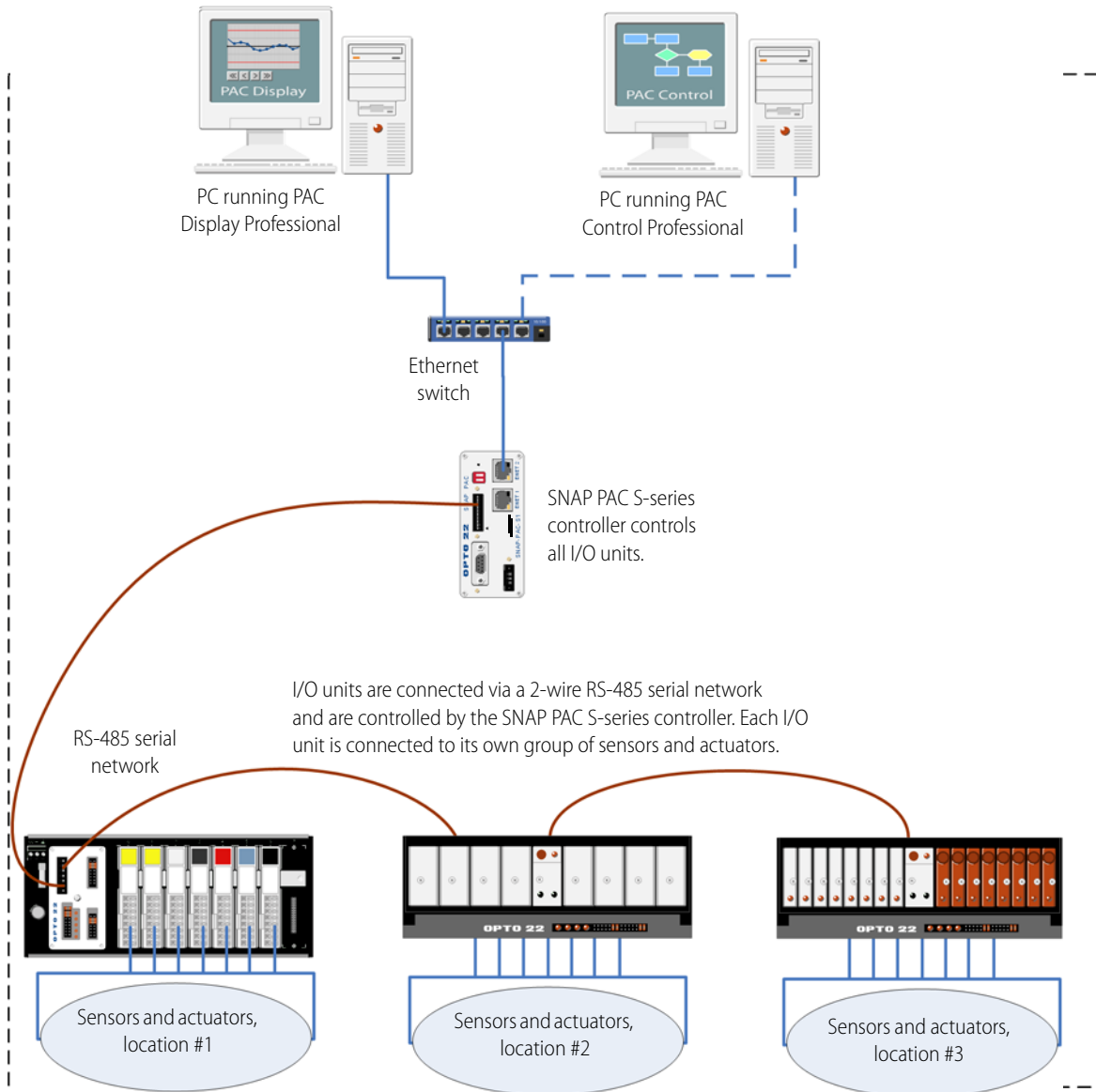

This diagram shows a SNAP PAC S-series controller connected to multiple Opto 22 serial-based I/O units over an RS-485 serial network. The controller is also connected to a larger, separate enterprise Ethernet network to provide process data to a PC running Opto 22's PAC Display HMI software.

The diagram also shows a PC running PAC Control Professional; the control program (or *strategy*) that runs on the SNAP controller was developed in this application. Once developed, the strategy is downloaded to the controller and runs independently.

# SNAP PAC S-Series Controllers

## System Architecture (continued)

### SNAP-PAC-S2 Controller and Serial-based I/O Units

The network shown in this diagram requires PAC Control Professional and PAC Display Professional.

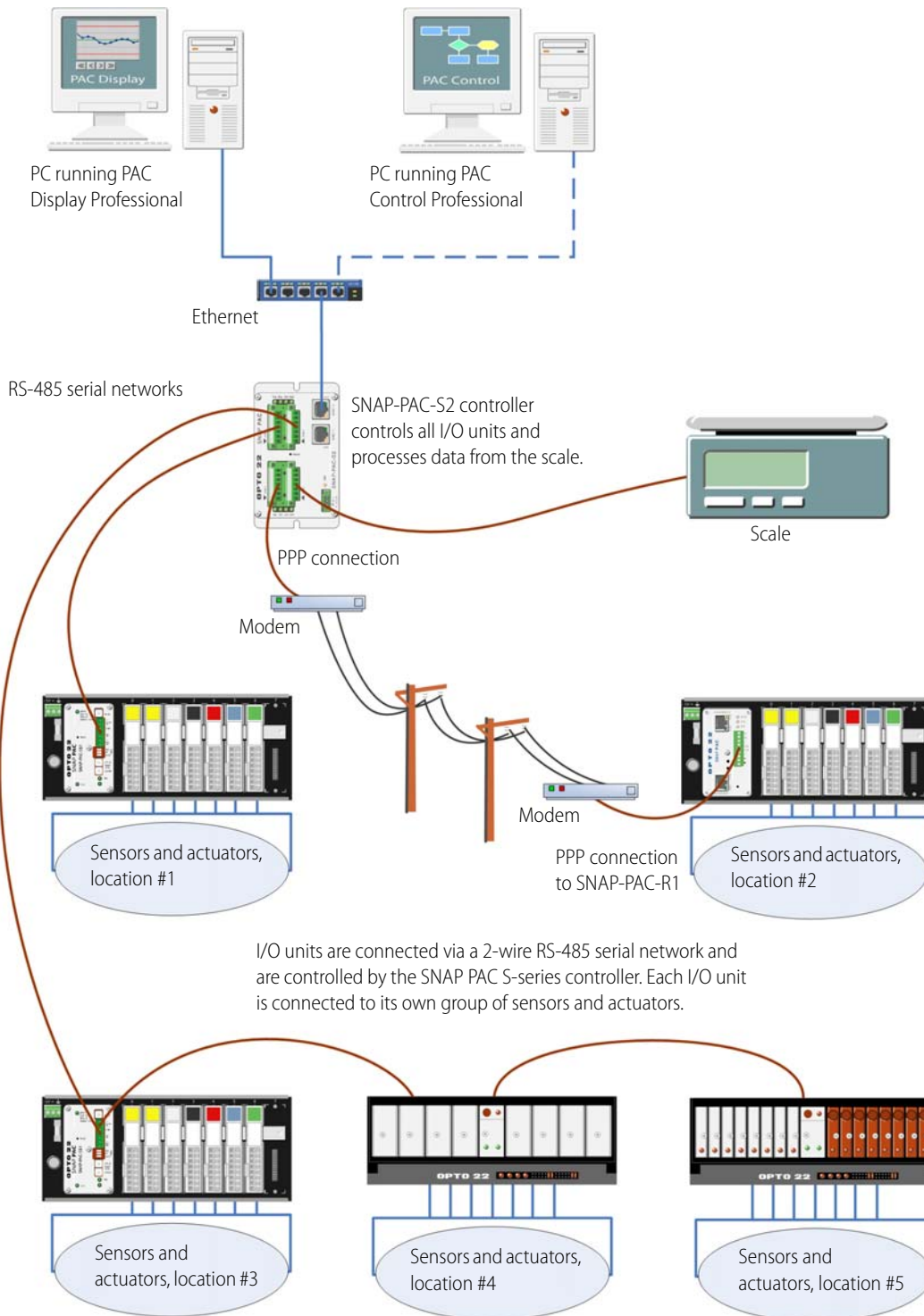

# SNAP PAC S-Series Controllers

## System Architecture (continued)

### Wired+Wireless SNAP PAC S-series Controller

The Wired+Wireless PAC can communicate with devices on wired networks, on a wireless LAN, or on both at once. It can also simultaneously communicate serially.

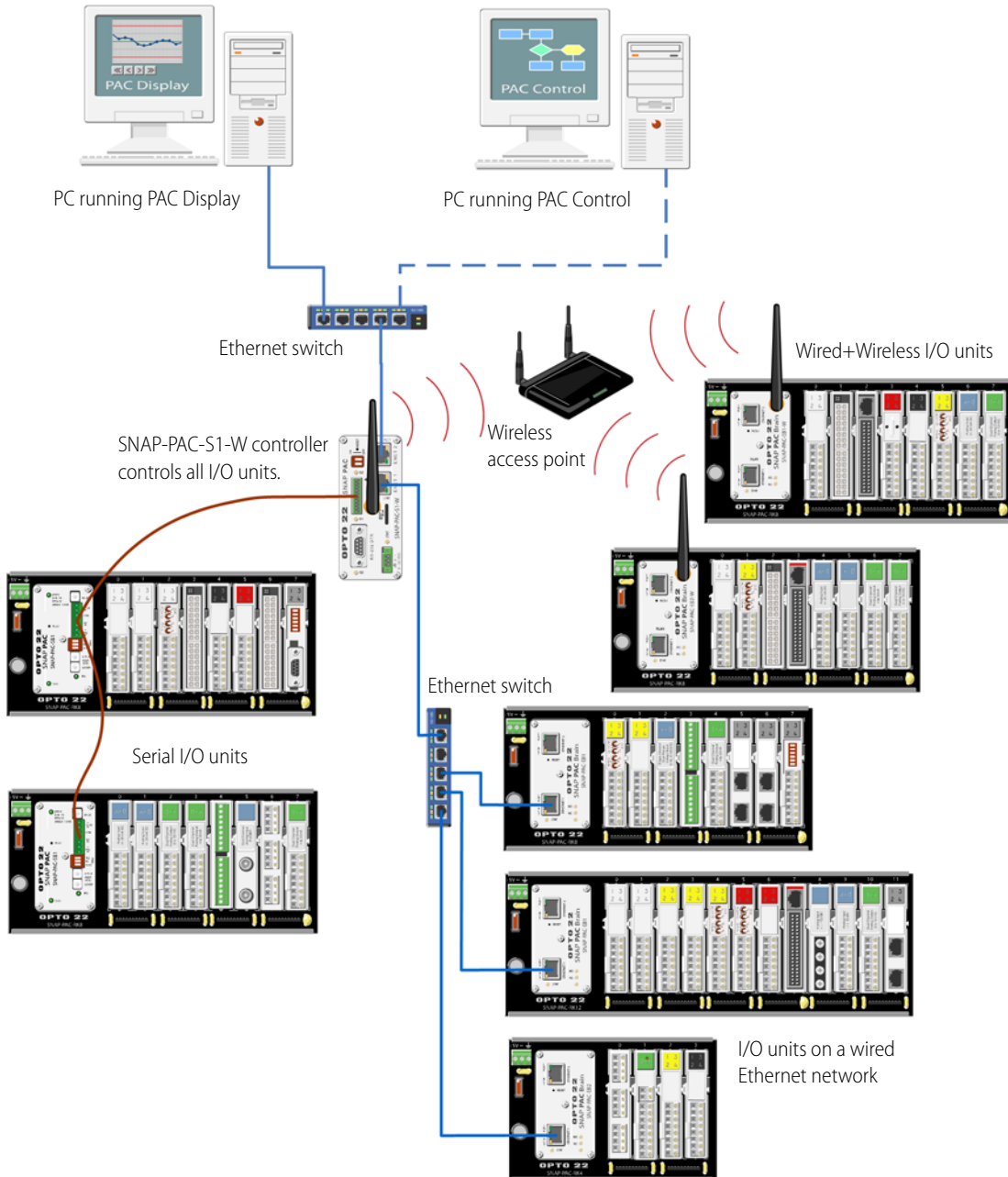

The Wired+Wireless SNAP PAC S-series controller is controlling three groups of I/O units: one group through its serial port, another through a standard 10/100 Mbps interface, and the third over a wireless LAN.

At the same time, the controller is connected to a second wired network for communication with PCs running PAC Control and PAC Display.



# SNAP PAC S-Series Controllers

## System Architecture (continued)

### SNAP PAC S-series Controller Segmenting Wired Ethernet Networks

The network shown in this diagram requires PAC Control Professional and PAC Display

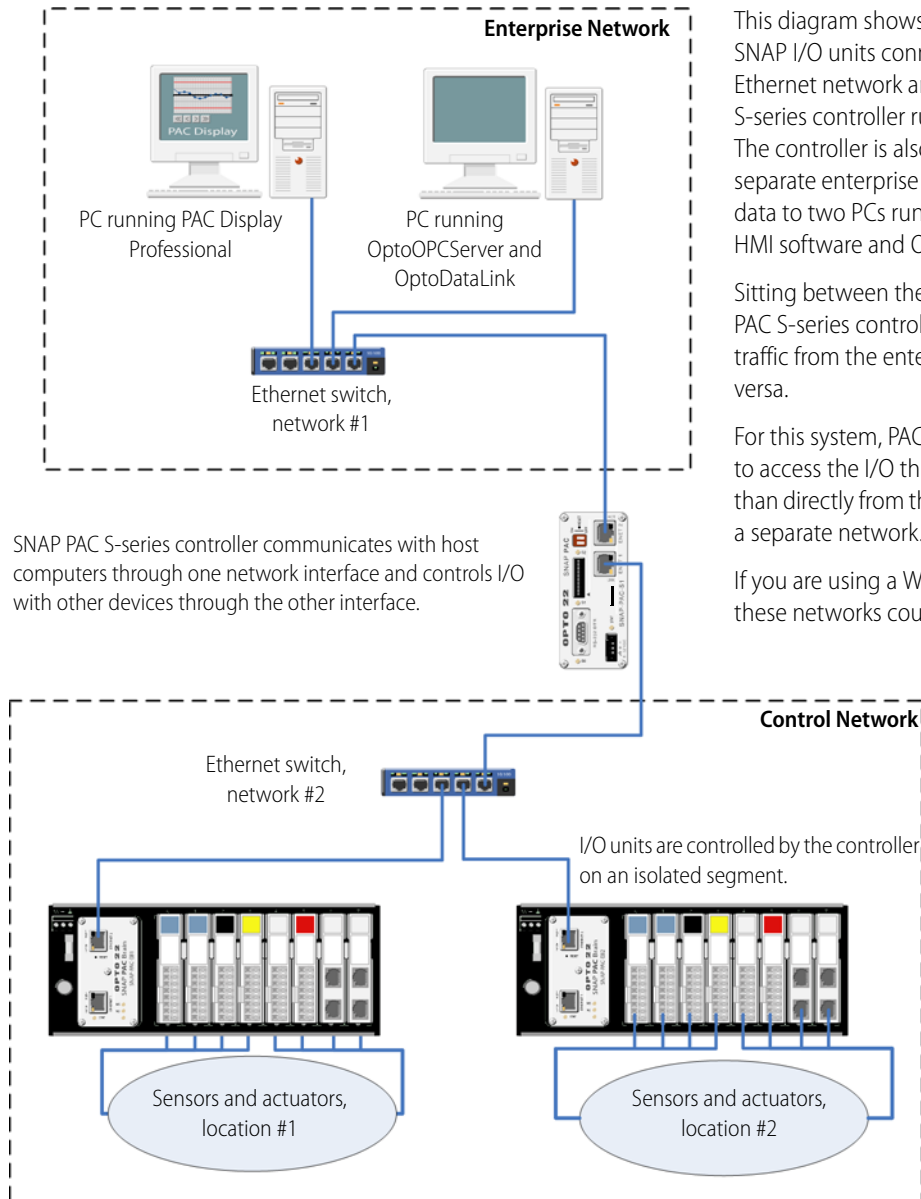

This diagram shows multiple Opto 22 SNAP I/O units connected together over an Ethernet network and controlled by a SNAP PAC S-series controller running a control strategy. The controller is also connected to a larger, separate enterprise Ethernet network to provide data to two PCs running Opto 22's PAC Display HMI software and OptoOPCServer.

Sitting between the two networks, the SNAP PAC S-series controller isolates I/O and control traffic from the enterprise network, and vice versa.

For this system, PAC Display must be configured to access the I/O through the controller rather than directly from the I/O units, since they are on a separate network.

If you are using a Wired+Wireless PAC, one of these networks could be a wireless LAN.

# SNAP PAC S-Series Controllers

## System Architecture

### SNAP PAC S-Series Controller in Redundant Network Configuration

The network shown in this diagram requires PAC Control Professional and PAC Display Professional.

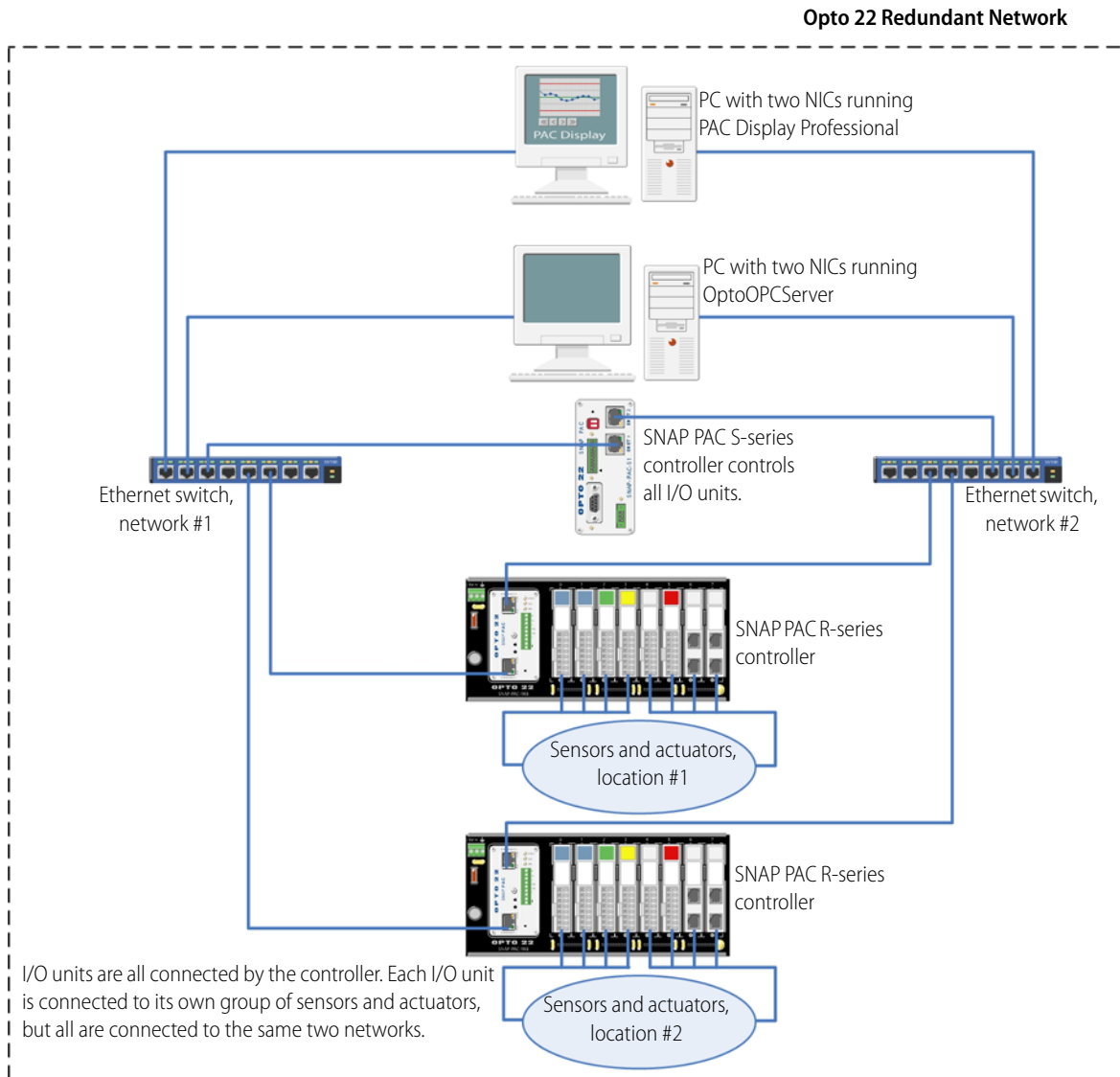

This diagram shows a SNAP PAC S-series controller connected to two separate Ethernet networks. This configuration addresses the concern that an Ethernet network may fail or need maintenance, leaving the PC running OptoOPCServer, the PC running PAC Display, the controller, and the I/O units unable to communicate.

In this configuration, if one network goes down, devices can still communicate on the other. Each PC has two network interface cards (NICs), and the SNAP PAC S-series controller and the I/O units (SNAP PAC R-series) have two network interfaces as well.

If you are using Wired+Wireless PACs, one of these networks can be a wireless LAN.

# SNAP PAC S-Series Controllers

## System Architecture (continued)

### SNAP PAC S-series Redundant Controllers

Controller redundancy requires PAC Project Professional 9.0 or newer.

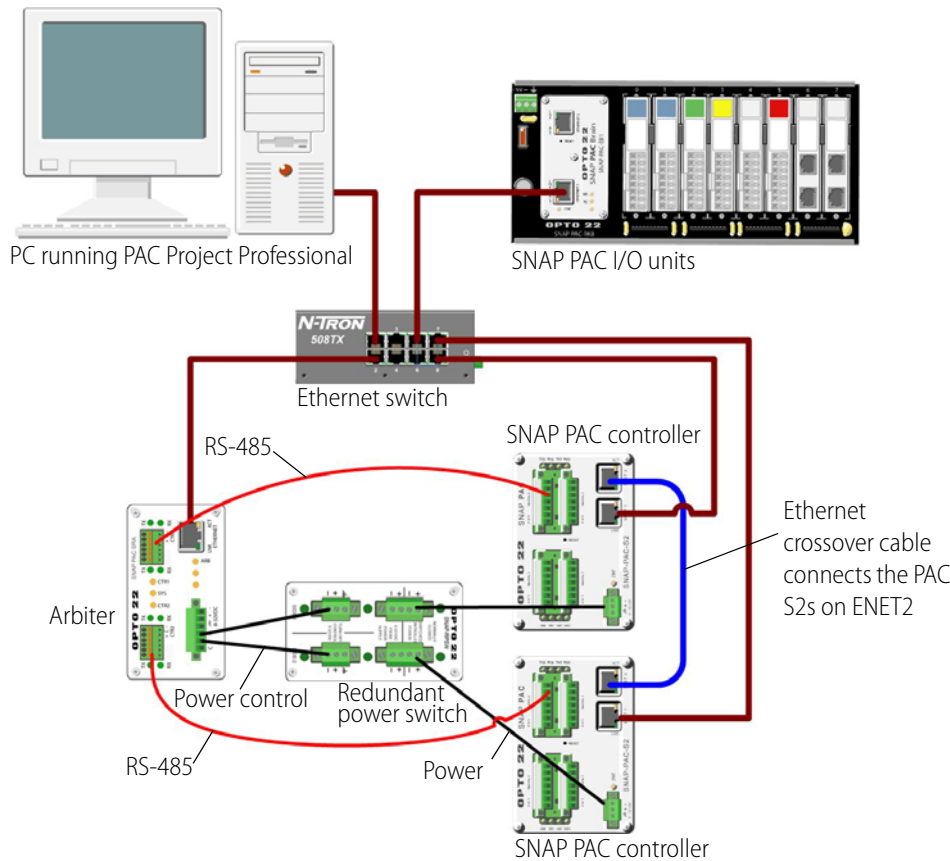

In this diagram, two S-series controllers are operating redundantly. One is the active controller, while the other acts as a backup, ready to take over should the first one fail.

Controller redundancy requires PAC Project Professional 9.0 or newer and the Redundancy Option Kit, which includes the arbiter and the redundant power switch in this diagram. PAC Redundancy Manager, a software utility for setting up and maintaining the system, is included in PAC Project Pro.

The two controllers you use must be exactly the same part number (for example, two SNAP-PAC-S2 controllers or two SNAP-PAC-S1-W controllers).

One advantage of an Opto 22 redundant system is that it uses standard PACs, standard cabling, and standard I/O. Another advantage is that either controller can act as the active or backup controller; you can switch their roles at any time for maintenance, for example.

For detailed information on redundancy, see form 1831, the *SNAP PAC System Redundancy User's Guide*.

# SNAP PAC S-Series Controllers

## SNAP-PAC-S1 Connectors and Indicators

This diagram applies to both the SNAP-PAC-S1 and the SNAP-PAC-S1-FM.

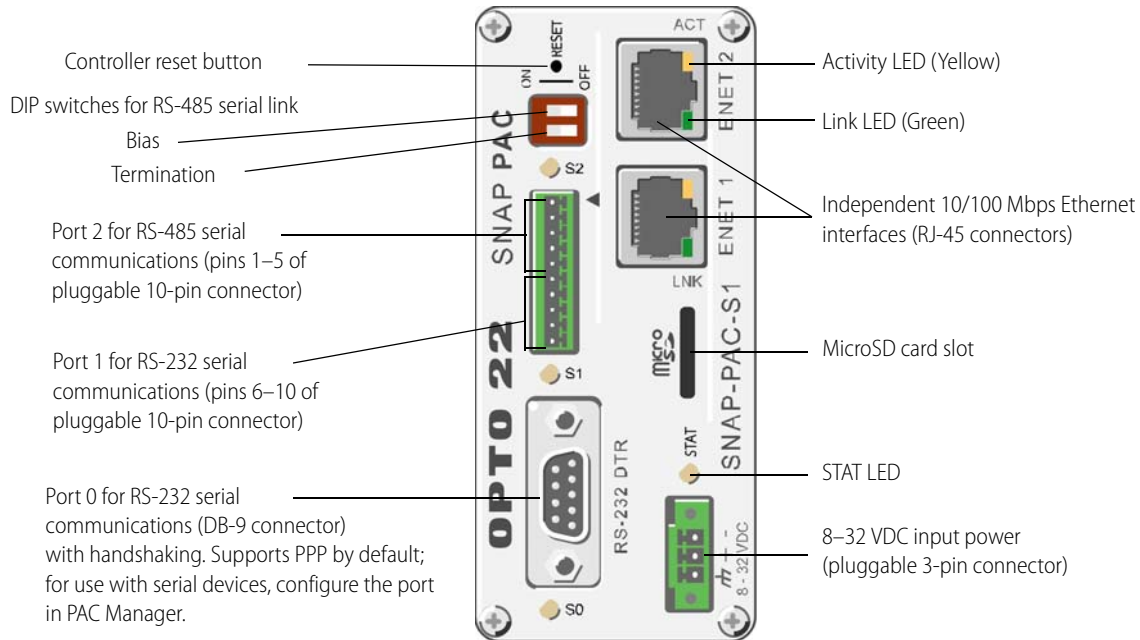

### Status and Activity LEDs

Indicator	Description
S0	RS-232 serial activity on port 0
S1	RS-232 serial activity on port 1
S2	RS-485 serial activity
STAT	Startup status and control program operational status
ACT	Ethernet network activity
LINK	Link established with Ethernet network

### Port 0 for RS-232 serial (DB-9 connector)

Pin	Description	Signal Direction
1	DCD	In
2	RX	In
3	TX	Out
4	DTR	Out
5	COM	
6	DSR	In
7	RTS	Out
8	CTS	In
9	RI*	In

\* RI signal does not occur on PACs with a microSD card slot

### Ports 1 and 2 for RS-485 and RS-232 serial

	Pin	Description	Signal Direction
Port 2 for RS-485 serial (2-Wire)	1	TX/RX+	In/Out
	2	TX/RX-	In/Out
	3	SIG COM*	
	4	IRQ+	In
	5	IRQ-	In
Port 1 for RS-232 serial	6	TX	Out
	7	RX	In
	8	GND	
	9	RTS	Out
	10	CTS	In

\* Isolated ground

# SNAP PAC S-Series Controllers

## SNAP-PAC-S1-W Connectors and Indicators (Wired+Wireless)

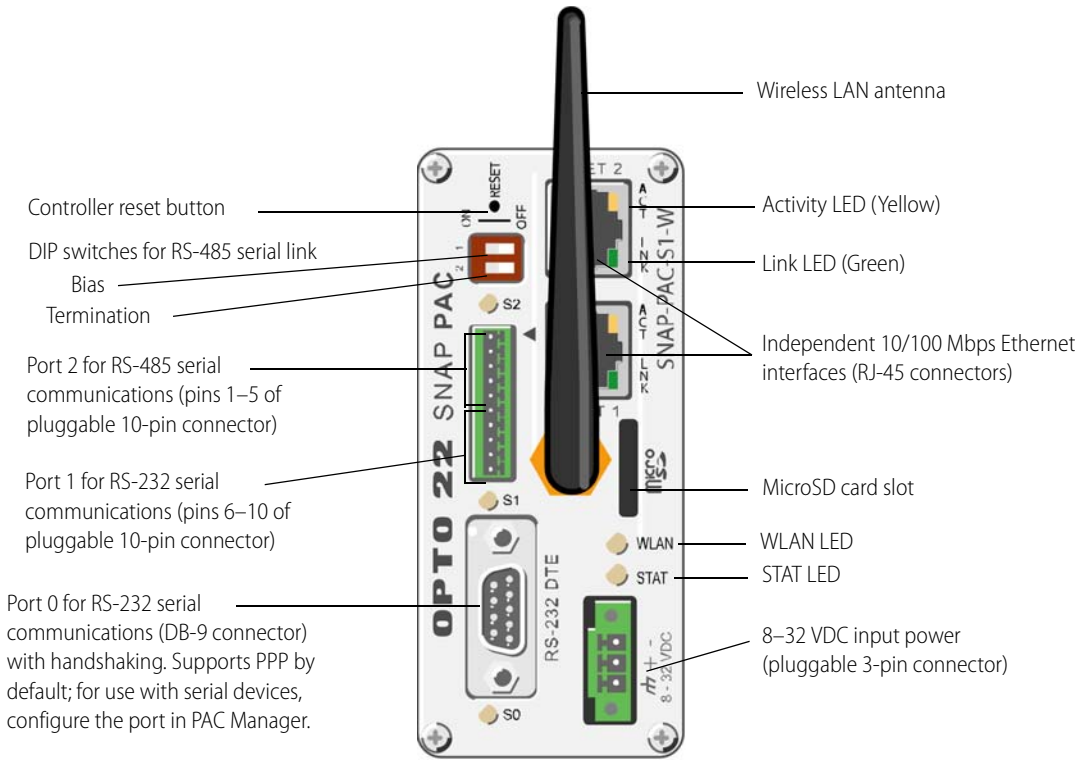

### Status and Activity LEDs

LED	Description
S0	RS-232 serial activity on port 0
S1	RS-232 serial activity on port 1
S2	RS-485 serial activity
STAT	Startup status and control program operational status
ACT	Ethernet network activity
LINK	Link established with Ethernet network
WLAN	Wireless LAN status

### Port 0 for RS-232 serial (DB-9 connector)

Pin	Description	Signal Direction
1	DCD	In
2	RX	In
3	TX	Out
4	DTR	Out
5	COM	
6	DSR	In
7	RTS	Out
8	CTS	In
9	NC*	

\* No connection

### Ports 1 and 2 for RS-485 and RS-232 serial

	Pin	Description	Signal Direction
Port 2 for RS-485 serial (2-Wire)	1	TX/RX+	In/Out
	2	TX/RX-	In/Out
	3	SIG COM*	
	4	IRQ+	In
	5	IRQ-	In
Port 1 for RS-232 serial	6	TX	Out
	7	RX	In
	8	GND	
	9	RTS	Out
	10	CTS	In

\* Isolated ground

# SNAP PAC S-Series Controllers

## SNAP-PAC-S2 Connectors and Indicators

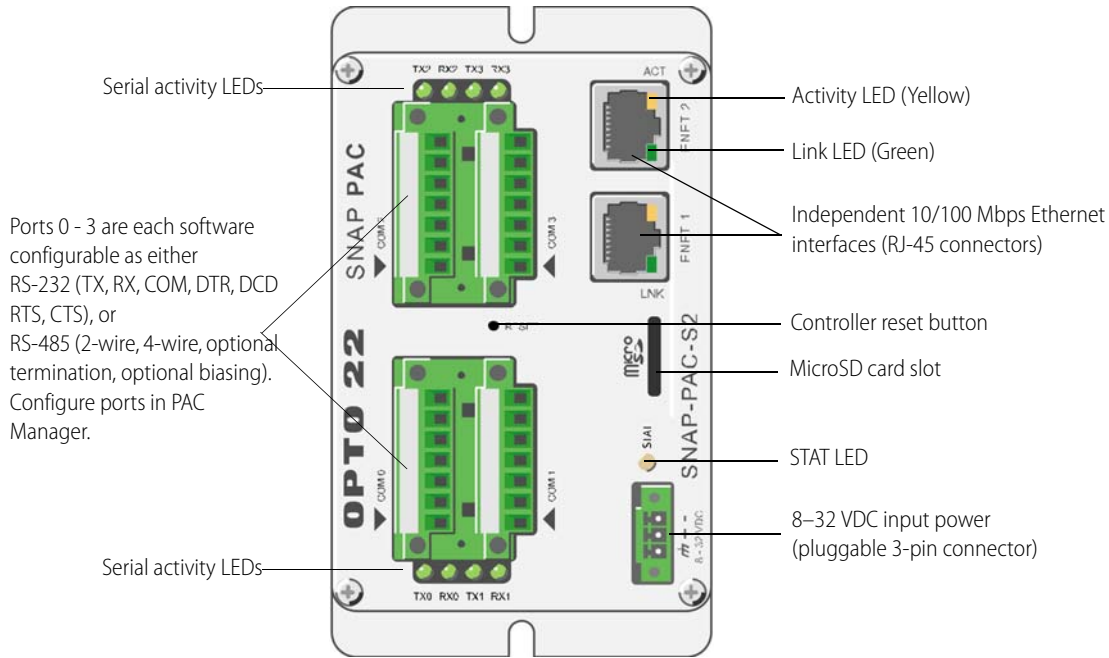

### RS-485 and RS-232 Ports<sup>1</sup>

Pin	RS-232	Signal Direction	RS-485	Signal Direction
1	TX	Out	TX/RX+	In/Out
2	RX	In	TX/RX-	In/Out
3	COM <sup>2</sup>		COM <sup>2</sup>	
4	RTS	Out	RX+ (4 wire)	In
5	CTS	In	RX- (4 wire)	In
6	DTR	Out	IRQ+	In
7	DCD	In	IRQ-	In

<sup>1</sup> **CAUTION: Do not use communication port connectors from a legacy OptoControl controller\***. Legacy connectors will fit in a SNAP-PAC-S2, but the pin orientation is different. Instead, use the connectors supplied with the SNAP-PAC-S2 controller.

<sup>2</sup> Isolated ground. (Each channel is isolated from the others.)

\*Legacy OptoControl Controllers:

G4LC32	G4LC32ISA-LT	M4RTU
G4LC32SX	M4	SNAP-LCM4
G4LC32ISA	M4IO	SNAP-LCSX/PLUS

### Status and Activity LEDs

Indicator	Description
TX0/RX0	Serial activity on port 0
TX1/RX1	Serial activity on port 1
TX2/RX2	Serial activity on port 2
TX3/RX3	Serial activity on port 3
STAT	Startup status and control program operational status
ACT	Ethernet network activity
LINK	Link established with Ethernet network

# SNAP PAC S-Series Controllers

## SNAP-PAC-S2-W Connectors and Indicators (Wired+Wireless)

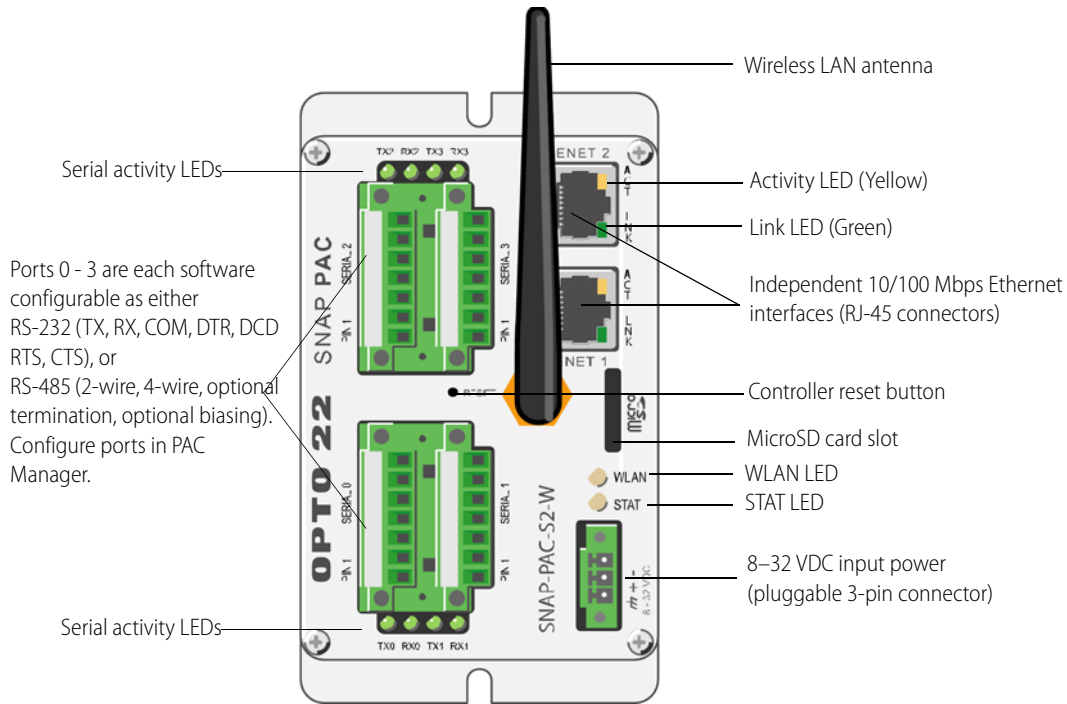

### RS-485 and RS-232 Ports<sup>1</sup>

Pin	RS-232	Signal Direction	RS-485	Signal Direction
1	TX	Out	TX/RX+	In/Out
2	RX	In	TX/RX-	In/Out
3	COM <sup>2</sup>		COM <sup>2</sup>	
4	RTS	Out	RX+ (4 wire)	In
5	CTS	In	RX- (4 wire)	In
6	DTR	Out	IRQ+	In
7	DCD	In	IRQ-	In

<sup>1</sup> **CAUTION: Do not use communication port connectors from a legacy OptoControl controller\*.** Legacy connectors will fit in a SNAP-PAC-S2, but the pin orientation is different. Instead, use the connectors supplied with the SNAP-PAC-S2 controller.

<sup>2</sup> Isolated ground. (Each channel is isolated from the others.)

\*Legacy OptoControl Controllers:

G4LC32	G4LC32ISA-LT	M4RTU
G4LC32SX	M4	SNAP-LCM4
G4LC32ISA	M4IO	SNAP-LCSX/PLUS

### Status and Activity LEDs

Indicator	Description
TX0/RX0	Serial activity on port 0
TX1/RX1	Serial activity on port 1
TX2/RX2	Serial activity on port 2
TX3/RX3	Serial activity on port 3
STAT	Startup status and control program operational status
ACT	Ethernet network activity
LINK	Link established with Ethernet network
WLAN	Wireless LAN status

# SNAP PAC S-Series Controllers

## Dimensional Drawings

### SNAP-PAC-S1 and SNAP-PAC-S1-FM Panel Mounting and Dimensions

For SNAP-PAC-S1-W dimensions, see [page 20](#)

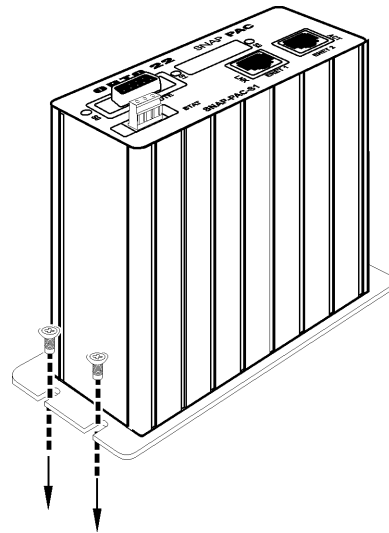
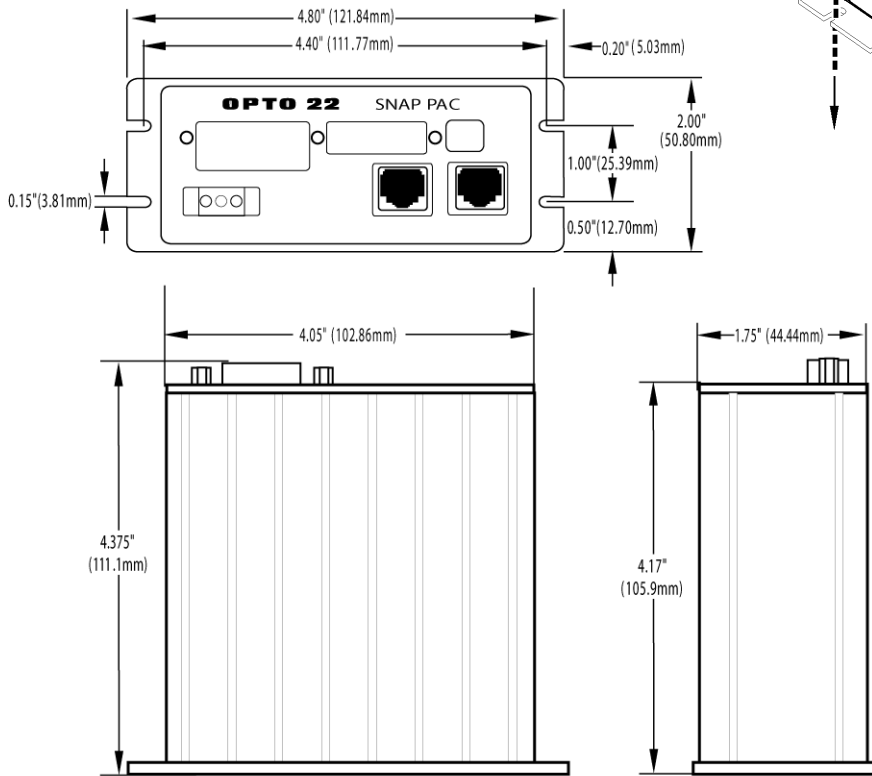



# SNAP PAC S-Series Controllers

## Dimensional Drawings (continued)

### SNAP-PAC-S1 and SNAP-PAC-S1-FM DIN-Rail Mounting and Dimensions

Requires a SNAP-PSDIN adapter (purchased separately).

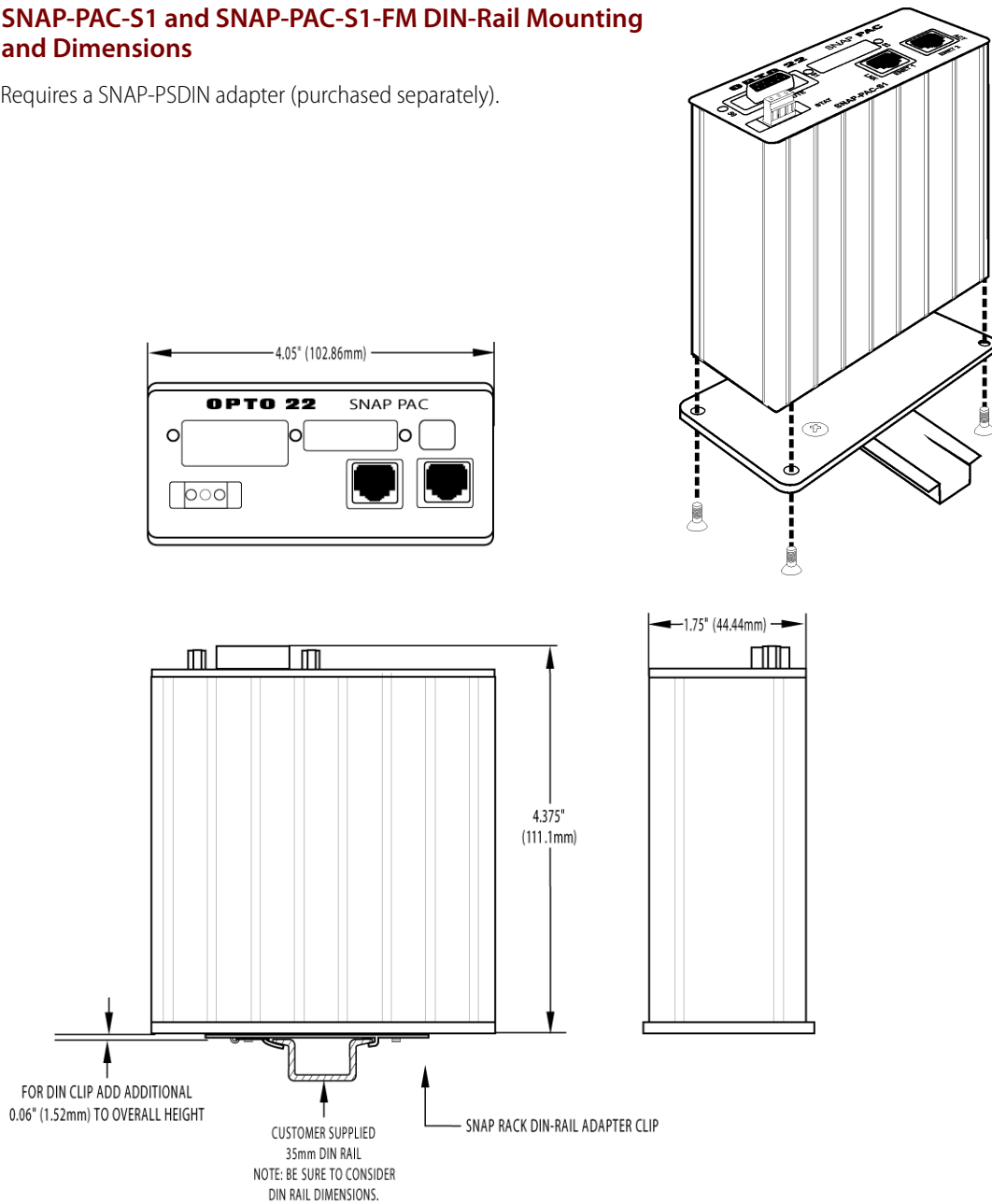

# SNAP PAC S-Series Controllers

## Dimensional Drawings (continued)

### SNAP-PAC-S2 Panel Mounting and Dimensions

For SNAP-PAC-S2-W dimensions, see [page 21](#)

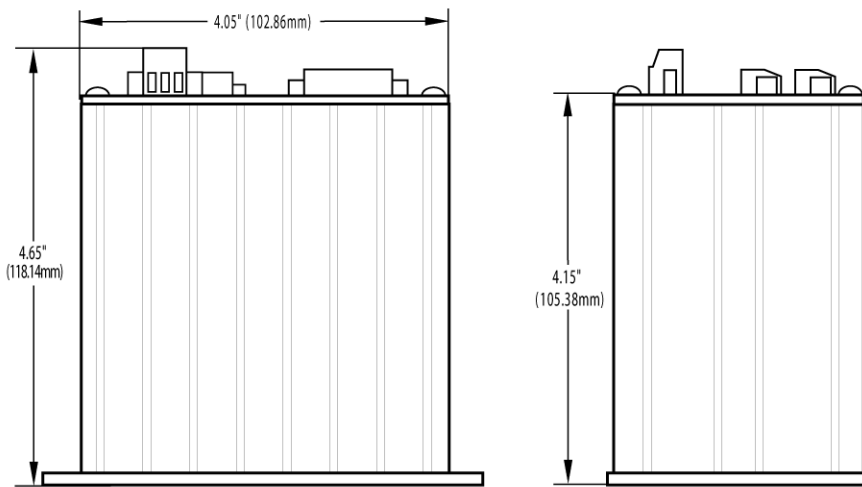
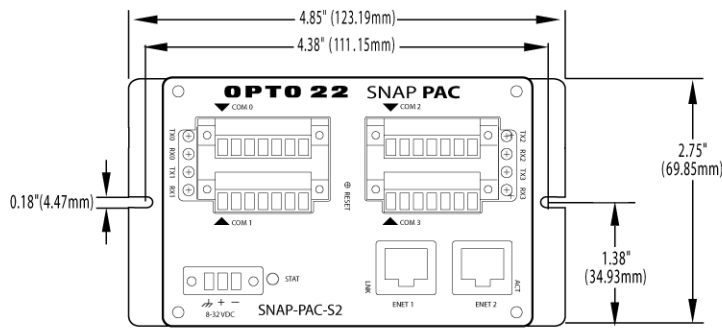
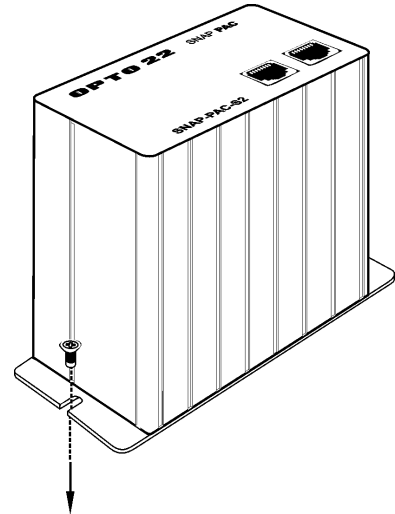

# SNAP PAC S-Series Controllers

## Dimensional Drawings (continued)

### SNAP-PAC-S2 DIN-Rail Mounting and Dimensions

Requires a SNAP-S2DIN adapter (purchased separately).

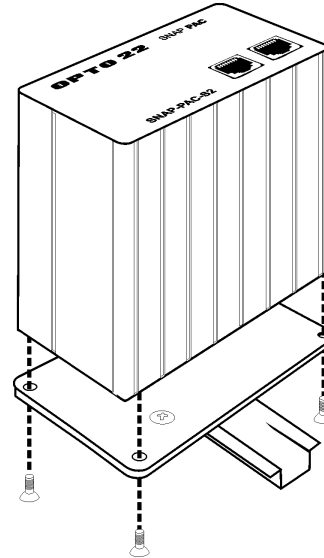
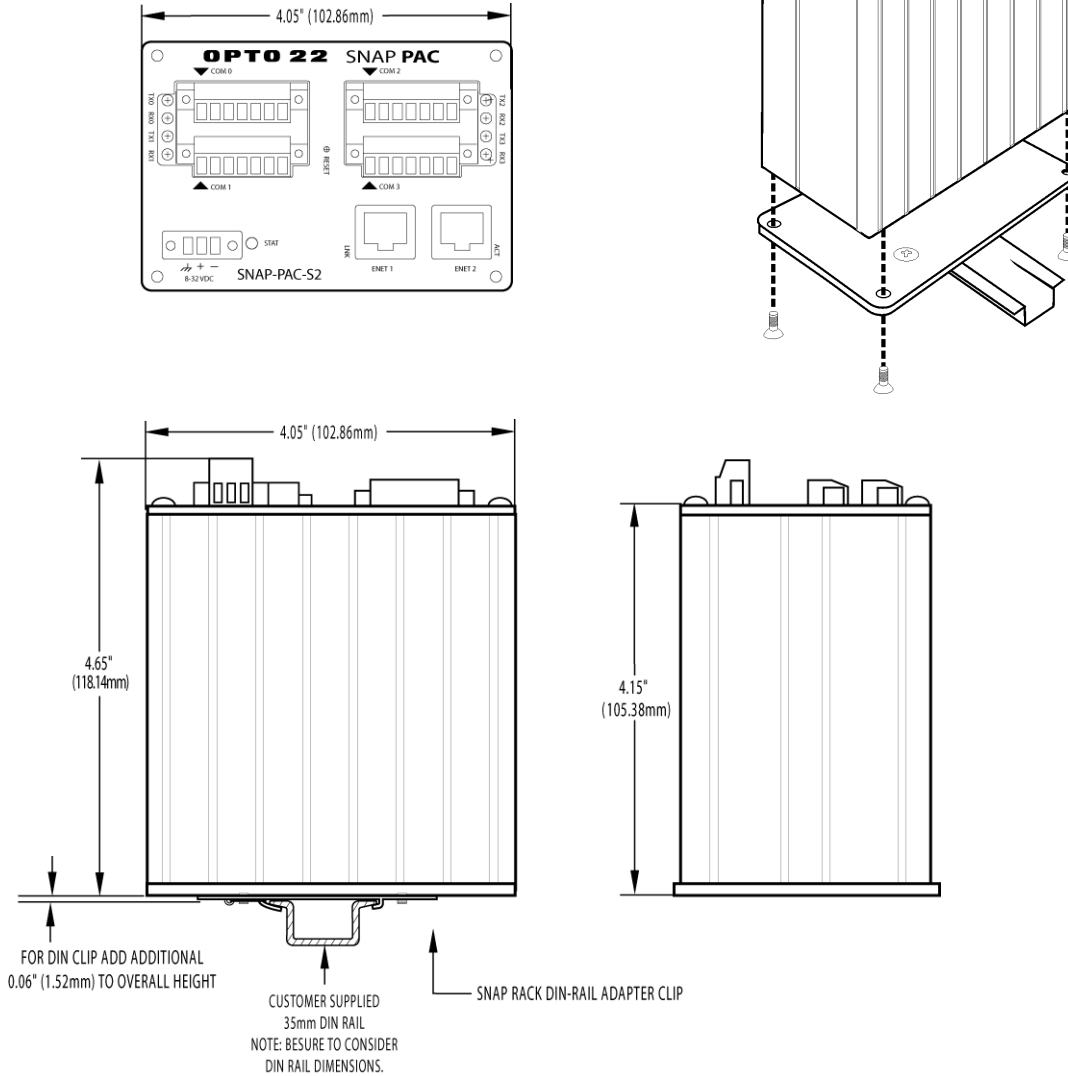

# SNAP PAC S-Series Controllers

## Dimensional Drawings (continued)

### SNAP-PAC-S1-W Dimensions

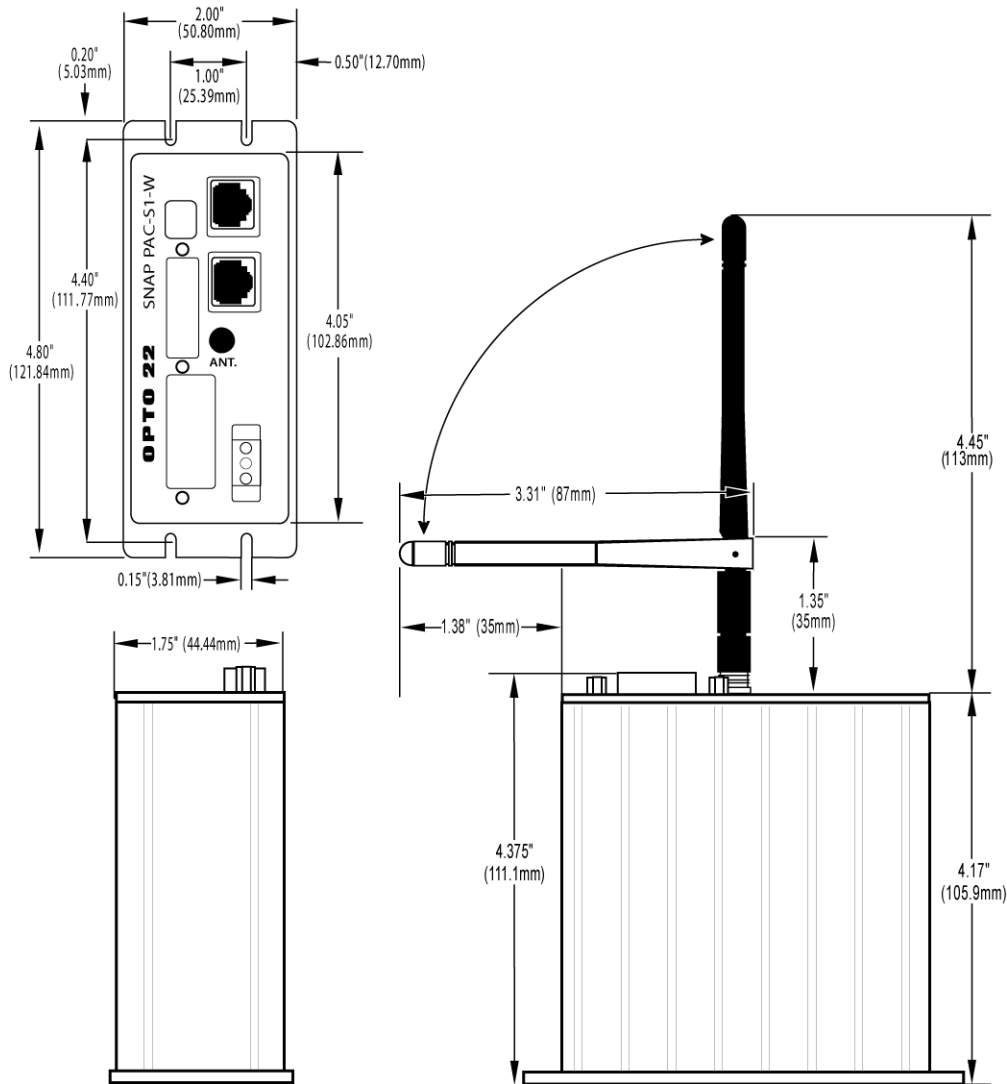

# SNAP PAC S-Series Controllers

## Dimensional Drawings (continued)

### SNAP-PAC-S2-W Dimensions

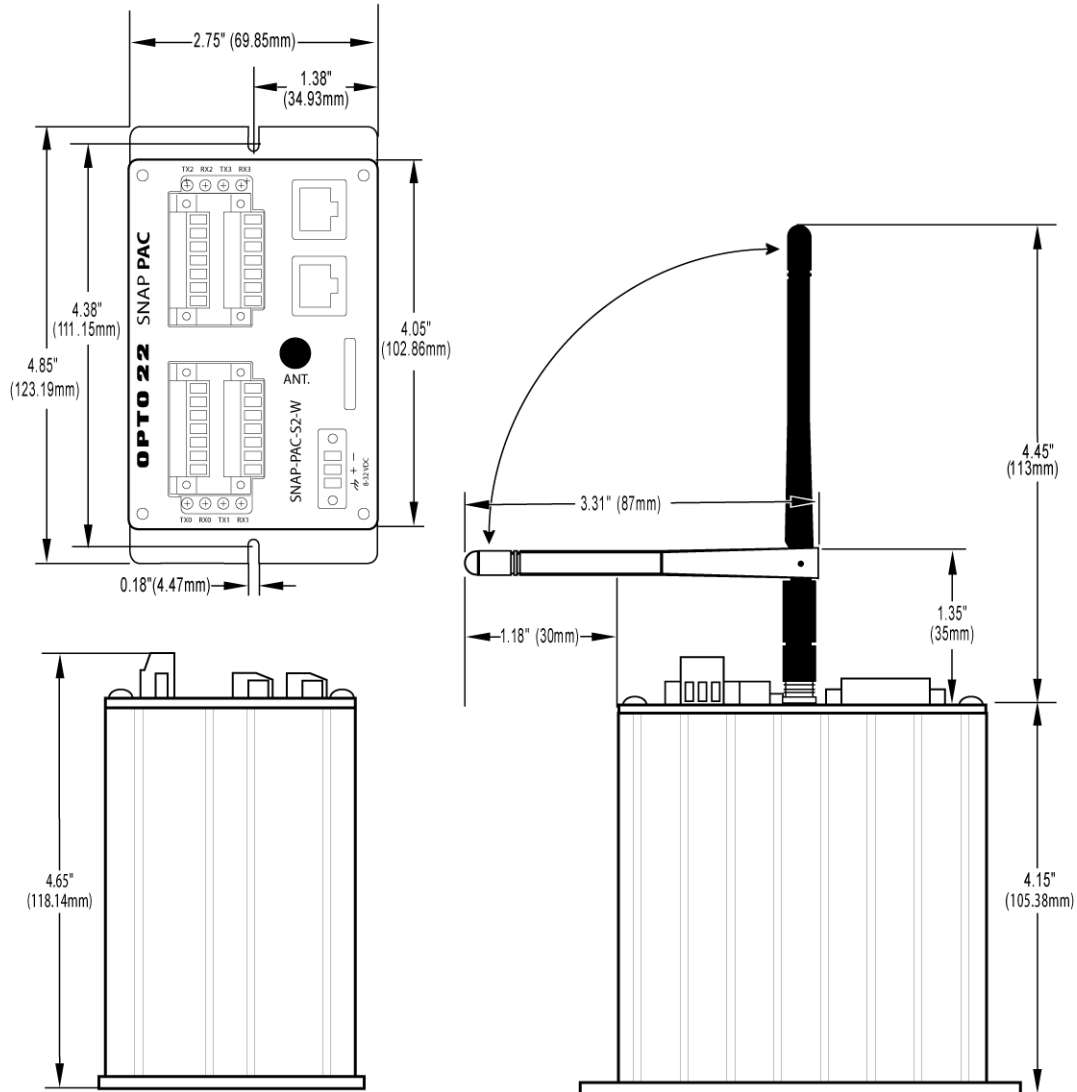

# More About Opto 22

## Products

Opto 22 develops and manufactures reliable, flexible, easy-to-use hardware and software products for industrial automation, remote monitoring, and data acquisition applications.

### SNAP PAC System

Designed to simplify the typically complex process of understanding, selecting, buying, and applying an automation system, the SNAP PAC System consists of four integrated components:

- SNAP PAC controllers
- PAC Project™ Software Suite
- SNAP PAC brains
- SNAP I/O™

### SNAP PAC Controllers

Programmable automation controllers (PACs) are multifunctional, multidomain, modular controllers based on open standards and providing an integrated development environment.

Opto 22 has been manufacturing PACs for many years. The latest models include the standalone SNAP PAC S-series and the rack-mounted SNAP PAC R-series. Both handle a wide range of digital, analog, and serial functions and are equally suited to data collection, remote monitoring, process control, and discrete and hybrid manufacturing.

SNAP PACs are based on open Ethernet and Internet Protocol (IP) standards, so you can build or extend a system without the expense and limitations of proprietary networks and protocols.

### PAC Project Software Suite

Opto 22's PAC Project Software Suite provides full-featured and cost-effective control programming, HMI (human machine interface) development and runtime, OPC server, and database connectivity software to power your SNAP PAC System.

These fully integrated software applications share a single tagname database, so the data points you configure in PAC Control™ are immediately available for use in PAC Display™, OptoOPCServer™, and OptoDataLink™. Commands are in plain English; variables and I/O point names are fully descriptive.

PAC Project Basic offers control and HMI tools and is free for download on our website, [www.opto22.com](http://www.opto22.com). PAC Project Professional, available for separate purchase, adds OptoOPCServer, OptoDataLink, options for Ethernet link redundancy or segmented networking, and support for legacy Opto 22 serial *mistic*™ I/O units.

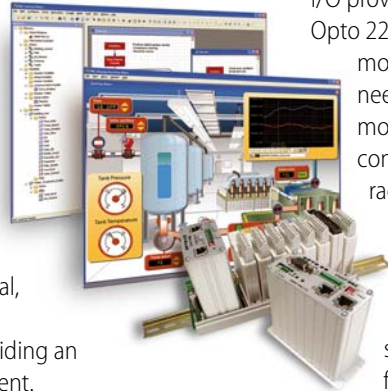

### SNAP PAC Brains

While SNAP PAC controllers provide central control and data distribution, SNAP PAC brains provide distributed intelligence for I/O processing and communications. Brains offer analog, digital, and serial functions, including thermocouple linearization; PID loop control; and optional high-speed digital counting (up to 20 kHz), quadrature counting, TPO, and pulse generation and measurement.

### SNAP I/O

I/O provides the local connection to sensors and equipment. Opto 22 SNAP I/O offers 1 to 32 points of reliable I/O per module, depending on the type of module and your needs. Analog, digital, serial, and special-purpose modules are all mixed on the same mounting rack and controlled by the same processor (SNAP PAC brain or rack-mounted controller).

## Quality

Founded in 1974 and with over 85 million devices sold, Opto 22 has established a worldwide reputation for high-quality products. All are made in the U.S.A. at our manufacturing facility in Temecula, California. Because we do no statistical testing and each part is tested twice before leaving our factory, we can guarantee most solid-state relays and optically isolated I/O modules for life.

## Free Product Support

Opto 22's Product Support Group offers free, comprehensive technical support for Opto 22 products. Our staff of support engineers represents decades of training and experience. Product support is available in English and Spanish, by phone or email, Monday through Friday, 7 a.m. to 5 p.m. PST.

## Free Customer Training

Hands-on training classes for the SNAP PAC System are offered at our headquarters in Temecula, California. Each student has his or her own learning station; classes are limited to nine students. Registration for the free training class is on a first-come, first-served basis. See our website, [www.opto22.com](http://www.opto22.com), for more information or email [training@opto22.com](mailto:training@opto22.com).

## Purchasing Opto 22 Products

Opto 22 products are sold directly and through a worldwide network of distributors, partners, and system integrators. For more information, contact Opto 22 headquarters at 800-321-6786 or 951-695-3000, or visit our website at [www.opto22.com](http://www.opto22.com).

[www.opto22.com](http://www.opto22.com)