

SNAP Analog Input Modules

Features

- Resolution = 0.004% of nominal range
- Two, 4, 8, or 32 single-ended inputs per module
- Out-of-range indication
- Operating temperature 0 °C to 70 °C
- Factory calibrated; no user adjustment necessary



SNAP Analog Input Modules

Description

SNAP I/O analog input modules are part of Opto 22's SNAP PAC System. All of these modules mount on a SNAP PAC rack with a SNAP PAC brain or R-series controller, either a standard wired model or a Wired+Wireless™ model.

A minimum number of SNAP module types support a full range of analog input requirements. These software-configurable modules handle a wide variety of signal levels. They provide high resolution (0.004% of nominal range) for precise signal levels, as well as multiple-channel packaging. All SNAP analog modules are factory calibrated and individually tested. Part numbers ending in -FM are Factory Mutual approved.

SNAP analog input modules have an on-board microprocessor to provide module-level intelligence, which makes them an ideal choice for Original Equipment Manufacturers (OEMs). For additional information about the standalone operation of SNAP analog modules, see Opto 22 form #0876, *SNAP I/O Module Integration Guide*.

Notes for legacy hardware: Some of these modules also work with older Opto 22 I/O processors (brains or on-the-rack controllers) and M-series or B-series racks. To check processor compatibility, see the table on [page 3](#).

Specifications begin on [page 4](#). For dimensional drawings, see pages [31–41](#).

IMPORTANT: Any system using analog sensors and input modules should be calibrated annually for analog signals. For I/O units on a SNAP PAC System, use the PAC Control™ commands “Calculate and Set Offset” and “Calculate and Set Gain.” For other Ethernet-based I/O units, you can also

Part Number

Part	Description	See page
SNAP-AIARMS	2-channel 0 to 10 amp RMS AC/DC input	4
SNAP-AIMA	2-channel analog current input, -20 to +20 mA	6
SNAP-AIMA-4	4-channel analog current input -20 to +20 mA	6
SNAP-AIMA-8	8-channel analog current input -20 to +20 mA	8
SNAP-AIMA-32 SNAP-AIMA-32-FM*	32-channel analog current input -20 to +20 mA	9
SNAP-AIRATE	2-channel 0–25,000 Hz analog rate input	11
SNAP-AIR40K-4	4-channel analog resistor/thermistor input, 40 K ohms, 20 K ohms, 10 K ohms, or 5 K ohms	13
SNAP-AIRTD	2-channel 100-ohm platinum RTD input	14
SNAP-AIRTD-10	2-channel 10-ohm copper RTD input	14
SNAP-AICTD	2-channel analog temperature input, ICTD	16
SNAP-AICTD-4	4-channel analog temperature input, ICTD	16
SNAP-AICTD-8	8-channel analog temperature input, ICTD	18
SNAP-AITM	2-channel analog type E, J, or K thermocouple or -150 to +150 mV input or -75 to +75 mV input	19
SNAP-AITM-2	2-channel analog type B, C, D, G, N, T, R, or S thermocouple or -50 to +50 mV DC or -25 to +25 mV DC input	20
SNAP-AITM-8 SNAP-AITM-8-FM*	8-channel B, C, D, E, G, J, K, N, R, S, or T thermocouple or -75 to +75 mV, -50 to +50 mV, or -25 to +25 mV input	21
SNAP-AIVRMS	2-channel 0 to 250 V RMS AC/DC input	22
SNAP-AIV	2-channel analog voltage input -10 to +10 VDC or -5 to +5 VDC	23
SNAP-AIV-4	4-channel analog voltage input -10 to +10 VDC or -5 to +5 VDC	23
SNAP-AIV-8	8-channel analog voltage input -10 to +10 VDC or -5 to +5 VDC	25
SNAP-AIV-32 SNAP-AIV-32-FM*	32-channel analog voltage input -10 to +10 VDC or -5 to +5 VDC	26
SNAP-AIMV2-4	4-channel -50 to +50 mV input or -25 to +25 mV input	28
SNAP-AIMV-4	4-channel -150 to +150 mV input or -75 to +75 mV input	29

* Factory Mutual approved

use PAC Manager™ software to calculate and set offset and gain.

Transformer and Optical Isolation

All SNAP analog input modules are transformer isolated and optically isolated from all other modules and from the SNAP I/O processor. The modules in this data sheet do not have channel-to-channel isolation, however. (If you need isolated analog modules, see Opto 22 form #1182.)

Optical isolation provides 4,000 volts of transient (4,000 V for 1 ms) protection for sensitive control electronics from industrial field signals.

Transformer isolation prevents ground loop currents from flowing between field devices and causing noise that produces erroneous readings. Ground loop currents are caused when two grounded field devices share a connection, and the ground potential at each device is different.

IMPORTANT: Since these analog input modules provide multiple single-ended input channels with a common reference, the channels are not isolated from each other. (See Opto 22 form #1182 for isolated modules.)

Bipolar and Unipolar Input Modules

Most SNAP analog input modules are considered to be bipolar, which means the range extends equal amounts above

SNAP Analog Input Modules

and below zero. An example of this is the SNAP-AIV module, which has a range of -10 to +10 VDC.

Some modules are considered unipolar, which means the range starts or ends at zero. For example, the SNAP-AIVRMS module has a range of 0 to 250 VAC because AC current cannot be negative.

Nominal Range and Over-range Limits

All SNAP analog input modules have a nominal range for the field signal and most support a 10% over-range limit. The nominal range is the normal range of the field signal for the module or point configuration. The over-range limit is the maximum valid field signal the module or point configuration can read outside of the nominal range. For example, the over-range limits for the SNAP-AIV are -11 and +11 VDC, and for the SNAP-AIVRMS, the over-range limit is 275 VAC.

Some modules or point configurations do not support field signals outside of the nominal range. For example, points configured as temperature inputs (thermocouple, RTD, ICTD) do not support over-range readings.

When the field signal is outside of the over-range limits of the module, the brain will not be able to determine if the value is too high or too low, so it will return an "out of range" value of -32768.0

Over-range limits only apply to input modules. Output modules are limited to their nominal ranges.

SNAP Analog Input Modules

Installation

Note module and processor compatibility in the following table:

Modules	Compatible I/O Processors
32-channel inputs 8-channel inputs SNAP-AIRTD-10	SNAP PAC R-series controllers and SNAP PAC brains, including Wired+Wireless models
4-channel inputs	SNAP PAC R-series controllers and SNAP PAC brains, including Wired+Wireless models Also the following legacy brains: SNAP Ethernet, SNAP Simple, SNAP Ultimate; SNAP-DNP-ASDS; SNAP OEM
2-channel inputs (except SNAP-AIRTD-10)	SNAP PAC R-series controllers and SNAP PAC brains, including Wired+Wireless models Also the following legacy brains: SNAP Ethernet, SNAP Simple, SNAP Ultimate; SNAP-DNP-ASDS; SNAP OEM; serial SNAP brains (B3000, Modbus, Profibus); B3000-HA; B6

All modules can be used with SNAP PAC racks and can be placed in any position on the rack. Two- and four-channel modules (except the SNAP-AIRTD-10) can also be used with legacy SNAP M-series and B-series mounting racks. (For more information on using legacy hardware, see form #1688, the *SNAP PAC System Migration Technical Note*.)

Modules snap securely into place in the row of connectors on the mounting rack. Each module connector has a number. Analog input modules and other types of SNAP I/O modules are mounted on the module connectors starting at module position zero.

Modules require a special tool (provided) for removal.

The following diagram shows part of a SNAP PAC mounting rack.

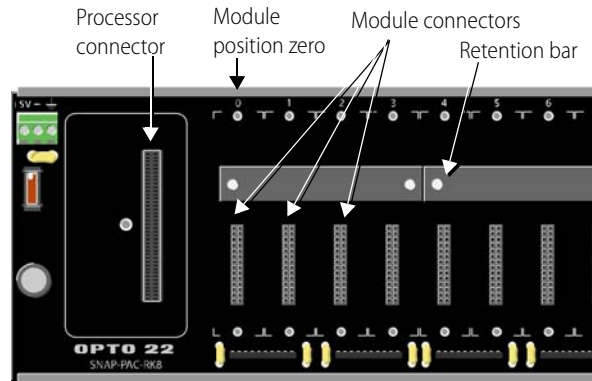

1. Place the rack so that the module connector numbers are right-side up, with zero on the left, as shown in the diagram above. (If your rack has screw connectors, the screw connectors will be at the bottom.)
2. Position the module over the module connector, aligning the small slot at the base of the module with the retention bar on the rack. When positioning modules next to each other, be sure to align the male and female module keys at the tops of the modules before snapping a module into position.
3. With the module correctly aligned, push on the module to snap it into place.
4. (Optional) Use standard 4-40 x 1/4 truss-head Phillips hold-down screws to secure both sides of each module.
CAUTION: Do not over-tighten screws.
5. Follow the wiring diagrams beginning on [page 4](#) to attach modules to the devices they monitor. Most modules accept up to 14 AWG wire; the SNAP-AITM-8 accepts a maximum of two solid 18 AWG wires.

For faster, easier field wiring installation and maintenance, use **SNAP TEX** cables and breakout boards. See Opto 22 form #1756, the *SNAP TEX Cables & Breakout Boards Data Sheet*, for compatibility and specifications.

0 to 10 Amp RMS AC/DC Input Module

Description

The SNAP-AIARMS module provides an input range of 0 to 10 amps RMS AC/DC. An ideal input is the 5-amp secondary of a standard current transformer used to monitor AC line current.

The SNAP-AIARMS module may be used to monitor AC current to greater than a 100-amp range, using a current transformer of suitable ratio.

If you need a module with channel-to-channel isolation, see form #1182, the *SNAP Isolated Analog Input Modules Data Sheet*.

Wiring diagrams are on the following page.



SNAP Analog Input Modules

Part Number	Description
SNAP-AIARMS	Two-channel 0 to 10 amp RMS AC/DC input

Specifications

Input Range	0 to 10 amp RMS AC/DC
Input Over-Range	To 11 amps
Input Resistance	0.005 ohms
Maximum Input	11 amps AC/DC
Accuracy (AC)	±8 mA and ±0.2% reading
Resolution	400 microamps
DC Reversal	±16 mA (0.16%)
Input Response Time (Step Change)	5% (12.5 V) in 100 mS 63.2% (158 V) in 200 mS 99% (248 V) in 1200 mS
Data Freshness (Max)	32.3 ms
DC Common Mode Rejection	>-120 dB
AC Common Mode Rejection	>-120 dB at 60 Hz
Maximum Operating Common Mode Voltage	250 V
Isolation	1500 V
Power Requirements	5 VDC (±0.15 V) at 170 mA
Operating Temperature	0 °C to 70 °C
Storage Temperature	-25 °C to 85 °C
Torque, hold-down screws	4 in-lb (0.45 N-m)
Torque, connector screws	5.26 in-lb (0.6 N-m)
Agency Approvals	UL, FM, CE, RoHS, DFARS
Warranty	Lifetime

SNAP Analog Input Modules

0 to 10 Amp RMS AC/DC Input Module (continued)

SNAP-AIARMS Wiring Diagrams

Two possible wiring diagrams are shown below.

Terminals 3, 4, 7, and 8 share a common connection inside the module. **Make sure you observe polarity** when connecting the second channel. To avoid a potentially hazardous short, double-check wiring before turning on the current to be monitored.

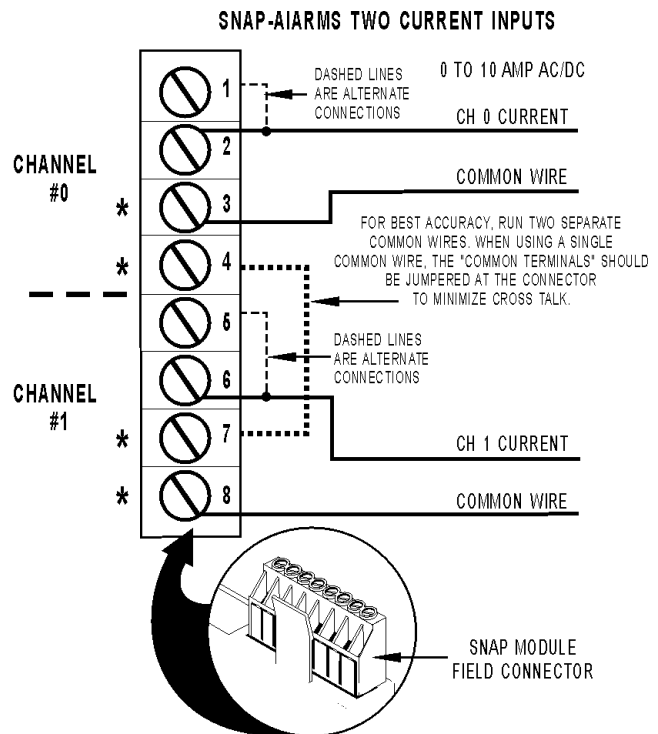
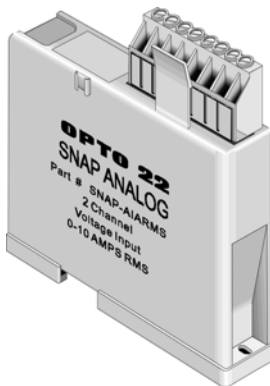
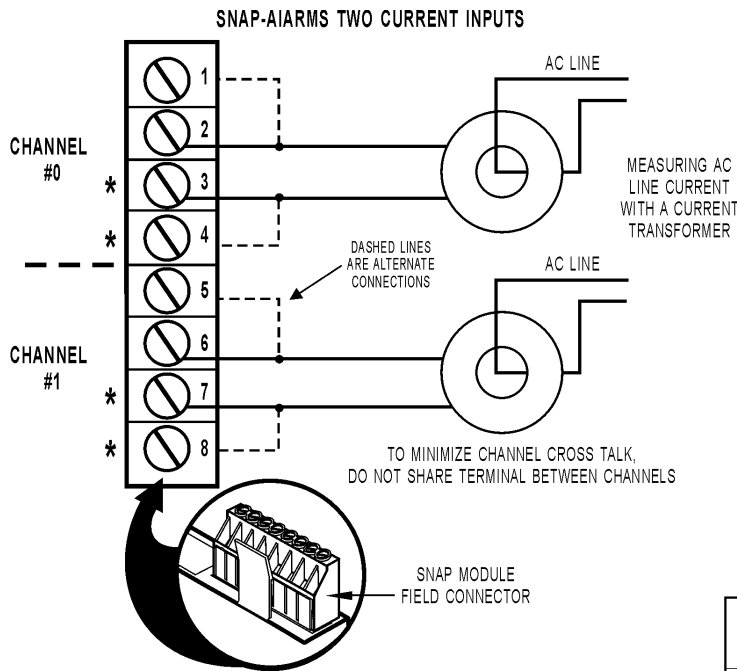

SNAP Analog Input Modules

Current Input Module, -20 mA to +20 mA, Two or Four Channels

Specifications

Input Range	-20 mA to +20 mA
Resolution	0.8 microamps
Over-Range Limits	From -22 to +22 mA (+/-20 mA range)
Input Response Time (% of span/ delta I/delta tme)	99.9% / 19.9 mA / 10 ms
Data Freshness (Max)	SNAP-AIMA: 11.5 ms SNAP-AIMA-4: 23 ms
DC Common Mode Rejection	>-120 dB
AC Common Mode Rejection	>-120 dB @ 60 Hz
Maximum Survivable Input	36 mA or 9 VDC
Maximum Operating Common Mode Voltage	250 V
Accuracy	0.05% (10 microamps)
DRIFT: Gain Temperature Coefficient	30 PPM/ °C
DRIFT: Offset Temperature Coefficient	15 PPM/ °C
Power Requirements	5 VDC (±0.15) @ 170 mA
Input Resistance - Single Ended	200 ohms (each channel)
Operating Temperature	0 °C to 70 °C
Storage Temperature	-25 °C to 85 °C
Torque, hold-down screws	4 in-lb (0.45 N-m)
Torque, connector screws	5.26 in-lb (0.6 N-m)
Agency Approvals	UL, FM, CE, RoHS, DFARS
Warranty	Lifetime

Part Number	Description
SNAP-AIMA	Two-channel analog current input, -20 mA to +20 mA
SNAP-AIMA-4	Four-channel analog current input, -20 mA to +20 mA

Description

The SNAP-AIMA and SNAP-AIMA-4 modules provide an input range of -20mA to +20mA. The SNAP-AIMA has two channels, and the SNAP-AIMA-4 has four. If you need a similar module with more channels, see [page 9](#). Check the table on [page 3](#) for I/O processor compatibility. These modules DO NOT supply loop excitation current.

Since all inputs share a common reference, the module must be installed at the beginning or end of a typical 4–20mA loop. If you are using both standard and self-sourcing transmitters, either put the transmitters on different modules or use different power supplies. If you need channels that are isolated from each other on the same module, see Opto 22 form #1182.



SNAP-AIMA Wiring (Two channels)

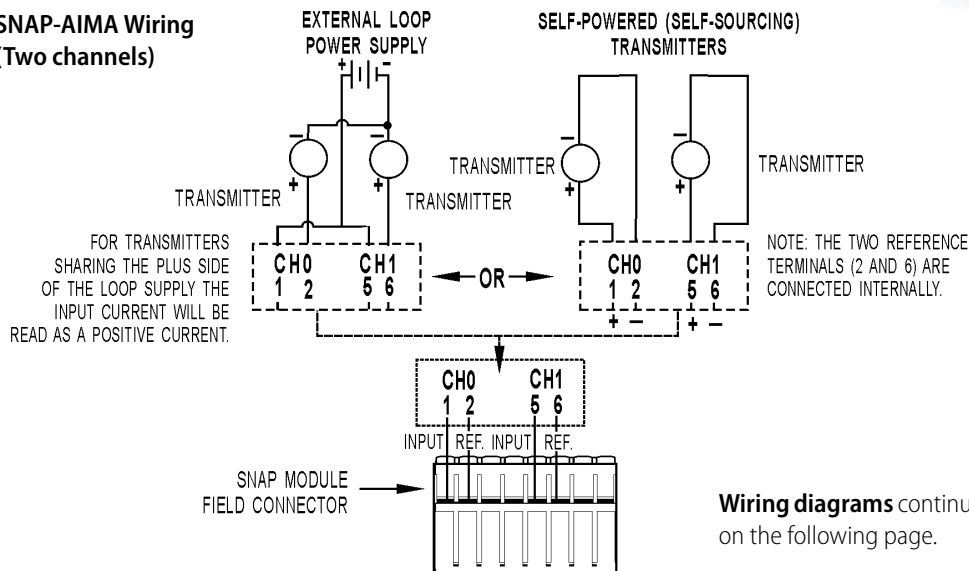

SNAP Analog Input Modules

Current Input Module, -20 mA to +20 mA, Two or Four Channels (continued)

SNAP-AIMA-4 Wiring (Four channels)

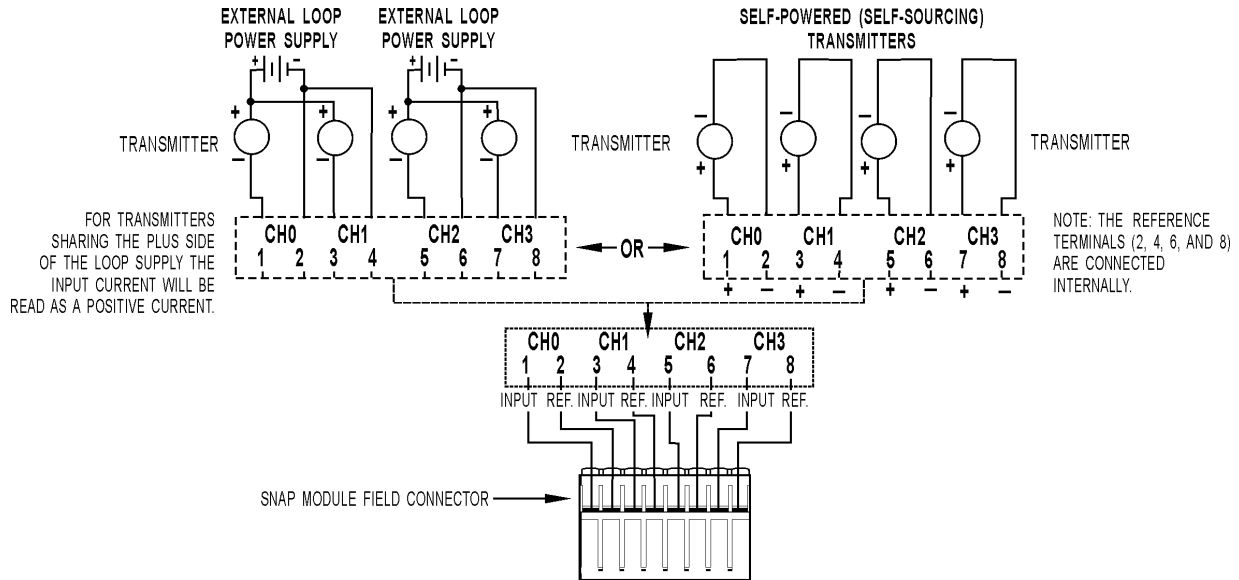

SNAP-AIMA Wiring: Positive Common vs. Negative Common Connections

The following diagrams apply to SNAP-AIMA-2, SNAP-AIMA-4, and SNAP-AIMA-8 modules.

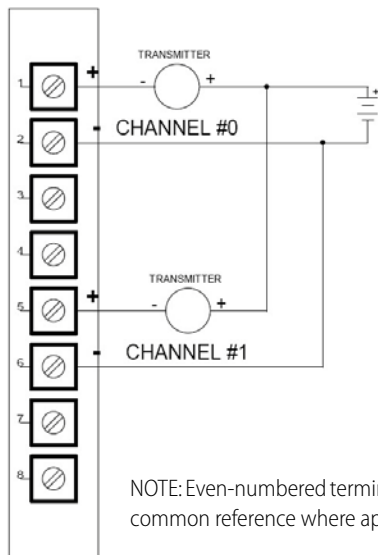

SNAP-AIMA

For transmitters sharing the plus side of the loop supply. Note that input current will be read as a positive current.

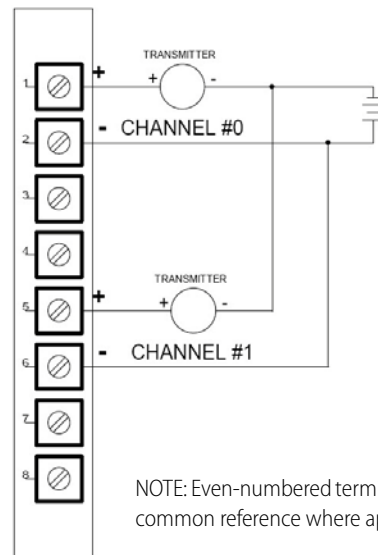

SNAP-AIMA

For transmitters sharing the minus side of the loop supply. Note that input current will be read as a negative current.

SNAP Analog Input Modules

Current Input Module, -20 mA to +20 mA, Eight Channels

SNAP-AIMA-8

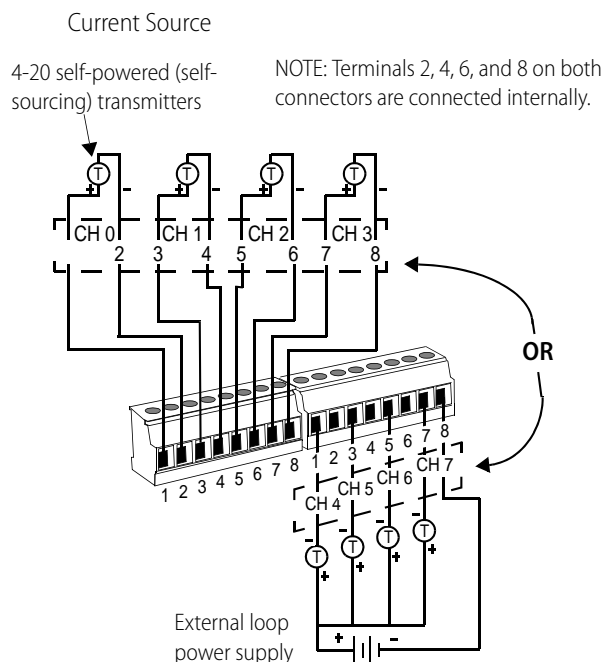

NOTE: For transmitters sharing the plus side of the loop power supply, the input current will be read as a positive current.

See additional wiring diagrams on [page 7](#).

Description

The SNAP-AIMA-8 module provides an input range of -20mA to +20mA with eight channels of analog current input. (If you need a similar module with 32 channels, see [page 9](#).) The SNAP-AIMA-8 can be used with SNAP PAC brains and rack-mounted controllers only. These modules DO NOT supply loop excitation current.

Since all inputs share a common reference, the module must be installed at the beginning or end of a typical 4–20mA loop. If you are using both standard and self-sourcing transmitters, either put the transmitters on different modules or use different power supplies. If you need channels that are isolated from each other on the same module, see Opto 22 form #1182.

If you have multiple self-sourcing transmitters that share the same positive common, do not use this module. Use the SNAP-AIMA-i module instead. See Opto 22 form #1182.

Part Number	Description
SNAP-AIMA-8	Eight-channel analog current input, -20 mA to +20 mA

Specifications

Input Range	-20 mA to +20 mA
Over-Range Limits	From -22 to +22 mA (+/-20 mA range)
Resolution	0.8 microamps
Data Freshness (Max)	0.28 seconds
DC Common Mode Rejection	>-120 dB
AC Common Mode Rejection	>-120 dB @ 60 Hz
Maximum Survivable Input	36 mA or 9 VDC
Maximum Operating Common Mode Voltage	250 V
Accuracy	0.05% (10 microamps)
DRIFT: Gain Temperature Coefficient	30 PPM/ °C
DRIFT: Offset Temperature Coefficient	15 PPM/ °C
Isolation	1500 V
Power Requirements	5 VDC (±0.15) @ 170 mA
Input Resistance - Single Ended	100 ohms (all channels share the same reference point)
Operating Temperature	0 °C to 70 °C
Storage Temperature	-25 °C to 85 °C
Torque, hold-down screws	4 in-lb (0.45 N-m)
Torque, connector screws	5.26 in-lb (0.6 N-m)
Agency Approvals	CE, RoHS, DFARS
Warranty	Lifetime



SNAP Analog Input Modules

Current Input Module, -20 mA to +20 mA, 32 Channels

Specifications

Input Range	-20 mA to +20 mA
Over-Range Limits	From -22 to +22 mA (+/-20 mA range)
Resolution	0.8 microamps
Input Filtering	-3 dB @ 31 Hz
Data Freshness (Max)	1.15 s
DC Common Mode Rejection	>-120 dB
AC Common Mode Rejection	>-120 dB @ 60 Hz
Maximum Survivable Input	36 mA or 9 VDC
Maximum Operating Common Mode Voltage	250 V
Accuracy	0.1% (20 microamps)
DRIFT: Gain Temperature Coefficient	30 PPM/ °C
DRIFT: Offset Temperature Coefficient	15 PPM/ °C
Isolation	1500 V, field to logic
Power Requirements	5 VDC (±0.15) @ 150 mA
Input Resistance - Single Ended	100 ohms (each channel)
Operating Temperature	0 °C to 70 °C
Storage Temperature	-25 °C to 85 °C
Torque, hold-down screws	4 in-lb (0.45 N-m)
Torque, connector screws	5.26 in-lb (0.6 N-m)
Agency Approvals	SNAP-AIMA-32: UL, CE, RoHS, DFARS. SNAP-AIMA-32-FM: CE, FM, RoHS, DFARS
Warranty	Lifetime

Description

The SNAP-AIMA-32 and SNAP-AIMA-32-FM modules provide 32 channels of input with an input range of -20mA to +20mA. The SNAP-AIMA-32-FM is Factory Mutual approved. Check the table on [page 3](#) for I/O processor compatibility. Dimensional drawings are on [page 35](#).



These modules DO NOT supply loop excitation current.

Channels are not isolated from each other. Since all inputs share a common reference, the module must be installed at the beginning or end of a typical 4–20 mA loop. If you use both standard and self-sourcing transmitters, put the

transmitters on different modules or use different power supplies. (If you need channels that are isolated from each other on the same module, see Opto 22 form #1182.)

Part Number	Description
SNAP-AIMA-32 SNAP-AIMA-32-FM	32-channel analog current input, -20 mA to +20 mA
SNAP-HD-BF6	Wiring harness for SNAP-AIMA-32 modules and breakout racks
SNAP-AIMA-HDB SNAP-AIMA-HDB-FM	Breakout racks for SNAP-AIMA-32 and SNAP-AIMA-32-FM

Wiring

SNAP TEX cables and a breakout rack are available separately for wiring points to field devices (see form #1756, the *SNAP TEX Cables & Breakout Boards Data Sheet*). The SNAP-HD-BF6 cable connects the module to the breakout rack, which can then be wired to field devices. (NOTE: The SNAP-HD-CBF6 wiring harness with flying leads is not recommended for this module.)

CAUTION: We strongly recommend that you use the breakout rack with these modules. Miswiring of any point on the module can cause severe out-of-warranty damage. The breakout rack protects the module from many wiring errors.

if you are using the module with loop power (2-wire) negative common devices, connect to the SNAP-AIMA-HDB (or -FM) rack. If you are using the module with self-powered devices (4-wire) or with devices that share a common positive connection, do not use the SNAP-AIMA-HDB (or -FM) boards, which have a current limiting diode. Instead, wire to the SNAP-AIV-HDB or SNAP-AIV-HDB-FM.

Correcting for Inverted Scaling

Positive readings for these modules appear as negative values. Therefore, in order to obtain meaningful readings, use the scaling feature in PAC Control as follows:

1. In the Add or Edit Analog Point dialog box for each point, choose the scalable version of the module.
2. Under Scaling, scale each point negatively as shown below:

SNAP Analog Input Modules

Current Input Module, -20 mA to +20 mA, 32 Channels (continued)

Wiring diagram: SNAP-AIMA-HDB breakout rack to SNAP-AIMA-32 module

NOTE: This diagram also applies to the SNAP-AIMA-HDB-FM rack and the SNAP-AIMA-32-FM module.

Use with loop power (2-wire) negative common devices only.

For self-powered (4-wire) devices, see [page 27](#).

For positive common devices, see [page 30](#).

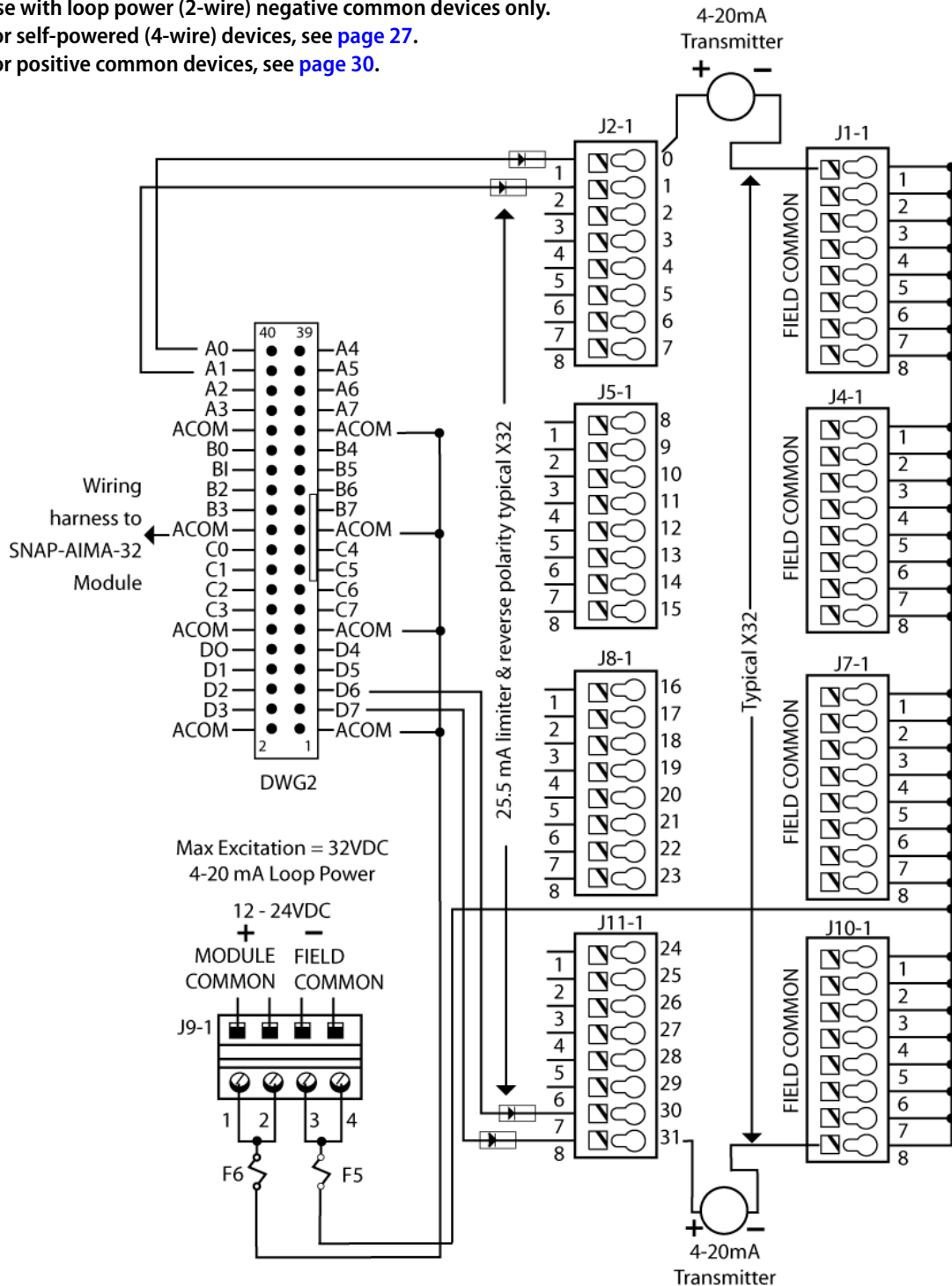

SNAP Analog Input Modules

0 to 25,000 Hz Analog Rate Input Module

Specifications

Nominal Input Range	0 to 25,000 Hz
Input Over-Range	To 27,500 Hz
Resolution	1 Hz
Input Response Time(% of span / delta Hz / delta time)	10.0% / 2,500 Hz / 0.1 sec 63.2% / 15.8 K Hz / 0.9 sec 99.0% / 24.75 K Hz / 4.2 sec
Data Freshness (Max)	126 ms
DC Common Mode Rejection	> -120 dB
AC Common Mode Rejection	> -120 dB at 60 Hz
Maximum Operating Common Mode Voltage	250 V
Accuracy (% full scale)	±4 Hz or ±0.5% of the input frequency (whichever is greater)
Drift: Gain Temperature Coefficient	200 ppm / °C
Drift: Offset Temperature Coefficient	50 ppm / °C
Input Coupling	Single-ended AC (capacitor coupled)
Input Amplitude Sine wave Square wave	2.5 V to 24 V p-p 0.5 V to 24 V p-p
Minimum Pulse Width	18 microseconds
Input Impedance (Inputs share the same reference point.) Pull-up Voltage Pull-up Resistor	50 K ohms AC coupled (-input to +input) 6 to 9 V 4.7 K ohms
Isolation	1500 V
Power Requirements	5 VDC (±0.15 V) at 190 mA
Operating Temperature	0 °C to 70 °C
Storage Temperature	-25 °C to 85 °C
Torque, hold-down screws	4 in-lb (0.45 N-m)
Torque, connector screws	5.26 in-lb (0.6 N-m)
Agency Approvals	UL, FM, CE, RoHS, DFARS
Warranty	Lifetime

Part Number	Description
SNAP-AIRATE	0–25,000 Hz analog rate input

Description

The SNAP-AIRATE module provides two channels of frequency-to-digital conversion. The nominal input range is 0 to 25,000 Hz with an over-range capability to 27,500 Hz. Nine volts through a 4.7 K ohm pull-up resistor are provided internally for use with devices that have open collector outputs. This feature eliminates the need for the user to provide the pull-up voltage supply and associated wiring, barrier strips, etc.

The module works with TTL, CMOS, and open collector outputs. Truly a two-wire hookup, the SNAP-AIRATE module is ideally suited for use with a tachometer.



SNAP Analog Input Modules

0 to 25,000 Hz Analog Rate Input Module (continued)

SNAP-AIRATE Wiring Diagrams

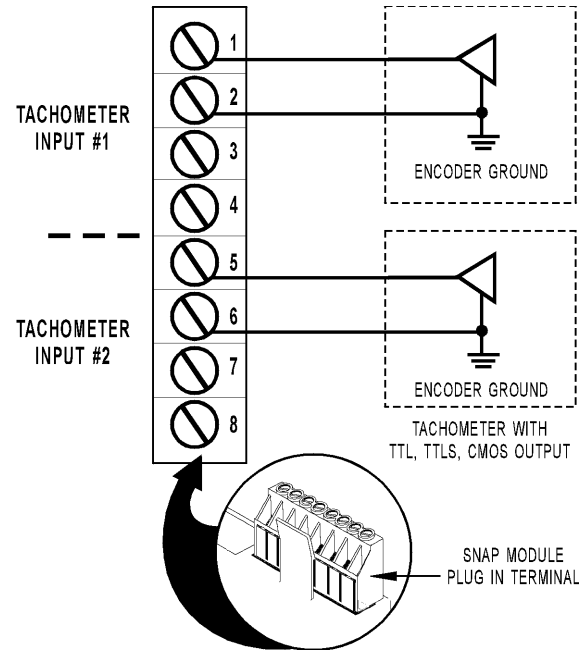
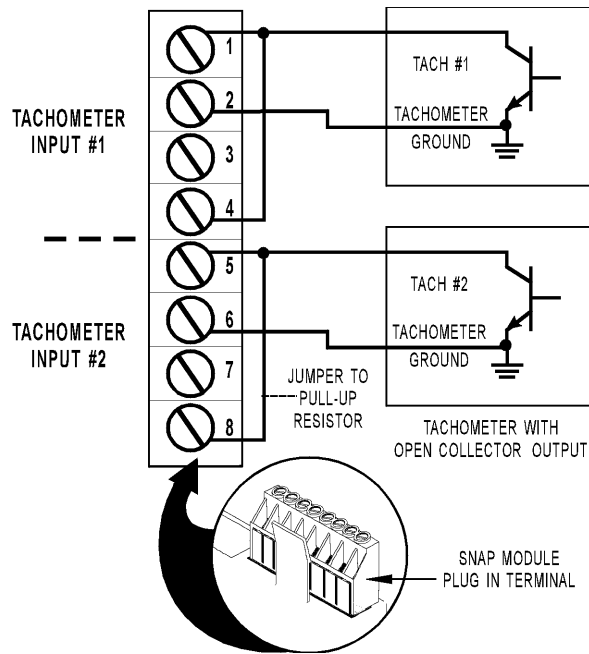

SNAP Analog Input Modules

Thermistor Input Module 0–40 K, 0–20 K, 0–10 K, or 0–5 K Ohm

SNAP-AIR40K-4

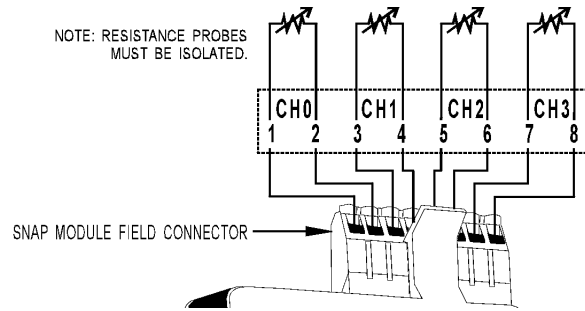

IMPORTANT: The mounting rack connector has 24 pins; the module connector has 20 pins. The extra pins on the mounting rack connector prevent misalignment of the module during installation.

Description

The SNAP-AIR40K-4 module provides four channels of analog to digital conversion, ideal for thermistors used in HVAC applications or for reading the resistance of potentiometer input. See the table on [page 3](#) for I/O processor compatibility.

The default input range is 0 to 40 K Ohms. The module can also be configured for 0 to 20 K, 0 to 10 K, or 0 to 5 K Ohms.

NOTE: Resistance probes must be isolated from each other.



Part Number	Description
SNAP-AIR40K-4	Four-channel analog resistor/thermistor input, 40 K ohms, 20 K ohms, 10 K ohms, or 5 K ohms

Specifications

Input Range	0 to 40,000 Ohms 0 to 20,000 Ohms 0 to 10,000 Ohms 0 to 5,000 Ohms
Maximum Over-Range	44 K (40 K Ohms range) 22 K (20 K Ohms range) 11 K (10 K Ohms range) 5.5 K (5 K Ohms range)
Resolution	1.6 Ohm @ 40 K Ohms 0.8 Ohm @ 20 K Ohms 0.4 Ohm @ 10 K Ohms 0.2 Ohm @ 5 K Ohms
Input Filtering	-3 dB @ 3.2 Hz
Data Freshness (Max)	100 (40 K Ohms) 200 (20 K Ohms) 400 (10 K Ohms) 800 (5 K Ohms)
DC Common Mode Rejection	>-120 dB
AC Common Mode Rejection	>-120 dB @ 60 Hz
Maximum Operating Common Mode Voltage	250 V
Accuracy	0.1% ± 40 Ohms @ 40 K Ohms 0.1% ± 20 Ohms @ 20 K Ohms 0.1% ± 10 Ohms @ 10 K Ohms 0.1% ± 5 Ohms @ 5 K Ohms
DRIFT: Gain Temperature Coefficient	30 PPM/ °C
DRIFT: Offset Temperature Coefficient	15 PPM/ °C
Isolation	1500 V
Power Requirements	5 VDC (±0.15) @ 190 mA
Operating Temperature	0 °C to 70 °C
Storage Temperature	-25 °C to 85 °C
Torque, hold-down screws	4 in-lb (0.45 N-m)
Torque, connector screws	5.26 in-lb (0.6 N-m)
Agency Approvals	UL, FM, CE, RoHS, DFARS
Warranty	Lifetime

SNAP Analog Input Modules

RTD Input Modules

SNAP-AIRTD and SNAP-AIRTD-10

See additional wiring details on the following page.

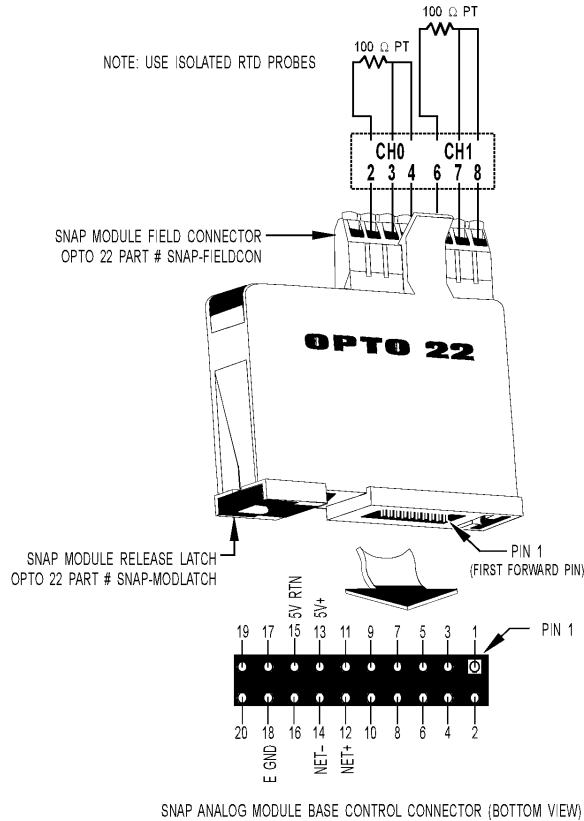

IMPORTANT: The mounting rack connector has 24 pins; the module connector has 20 pins. The extra pins on the mounting rack connector prevent misalignment of the module during installation.

Description

The SNAP-AIRTD platinum and SNAP-AIRTD-10 copper modules are usually used for temperature inputs. They can also be used to make high-resolution resistance measurements.

On both modules, the two inputs share the same reference terminal. Make sure you use isolated RTD probes.

The SNAP-AIRTD-10 requires a SNAP PAC brain or R-series controller.

Part Number	Description
SNAP-AIRTD	Two-channel 100-ohm platinum RTD input
SNAP-AIRTD-10	Two-channel 10-ohm copper RTD input

Specifications: SNAP-AIRTD

(See the following page for SNAP-AIRTD-10 specifications.)

3-wire RTD input	100-ohm platinum; $\alpha = 0.00385$
Input Temperature Range	-200 °C to 850 °C (-328° to +1,582° F)
Input Range	0 to 400 ohms
Over-Range Limit	to 400 ohms
Resolution (average)	0.042 °C (0.016 ohms)
Input Filtering	-3 dB @ 0.1 Hz
Data Freshness (Max)	100 ms
Input Response Time (% of span/delta temp/delta time)	63.2 %/598 °C/25 ms
Lead Compensation	Automatic when used with SNAP brains
DC Common Mode Rejection	>-120 dB
AC Common Mode Rejection	>-120 dB at 60 Hz
Excitation (typical)	1.25 mA constant current
Maximum Lead Resistance	>40 ohms single wire (all leads to be equal resistance)
Maximum Fault Voltage at Input (between any 2 field wires)	±15 V
Maximum Operating Common Mode Voltage	250 V
Accuracy From factory After setting gain and offset	0.8 °C 0.6 °C
Isolation	1500 V
Power Requirements	5 VDC (±0.15) @ 190 mA
Operating Temperature	0 °C to 70 °C
Storage Temperature	-25 °C to 85 °C
Torque, hold-down screws	4 in-lb (0.45 N-m)
Torque, connector screws	5.26 in-lb (0.6 N-m)
Agency Approvals	UL, FM, CE, RoHS, DFARS
Warranty	Lifetime

SNAP Analog Input Modules

RTD Input Modules (continued)

Specifications: SNAP-AIRTD-10

3-wire RTD input	10-ohm copper; $\alpha = 0.00428$
Input Temperature Range	-180 °C to 260 °C (-292° to +500° F)
Input Range	0 to 25 ohms
Over-Range Limit	to 27.5 ohms
Resolution (average)	0.026 °C (0.001 ohms)
Input Filtering	-3 dB @ 100 Hz
Data Freshness (Max)	168 ms
Lead Compensation	Automatic when used with SNAP PAC brains
DC Common Mode Rejection	>-120 dB
AC Common Mode Rejection	>-120 dB at 60 Hz
Excitation (typical)	5.4 mA constant current
Maximum Lead Resistance	>15 ohms single wire (all leads to be equal resistance)
Maximum Fault Voltage at Input (between any 2 field wires)	±15 V
Maximum Operating Common Mode Voltage	250 V
Accuracy From factory After setting gain and offset	0.6 °C 0.5 °C
Isolation	1500 V
Power Requirements	5 VDC (±0.15) @ 190 mA
Operating Temperature	0 °C to 70 °C
Storage Temperature	-25 °C to 85 °C
Torque, hold-down screws	4 in-lb (0.45 N-m)
Torque, connector screws	5.26 in-lb (0.6 N-m)
Agency Approvals	CE, RoHS, DFARS
Warranty	Lifetime

Connections

Two-wire
NOT recommended.

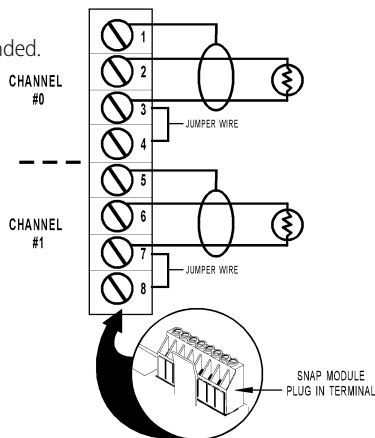

CAUTION: ACCURACY AND STABILITY WILL BE DEGRADED USING A 2-WIRE RTD

Wiring

The SNAP-AIRTD and SNAP-AIRTD-10 modules are designed for three-wire connections, shown in the diagram below.

If you use a four-wire connection (shown at the bottom right), DO NOT connect the fourth wire, as it will cause errors in the readings.

Two-wire connections (bottom left) are not recommended, as they will degrade accuracy and stability.

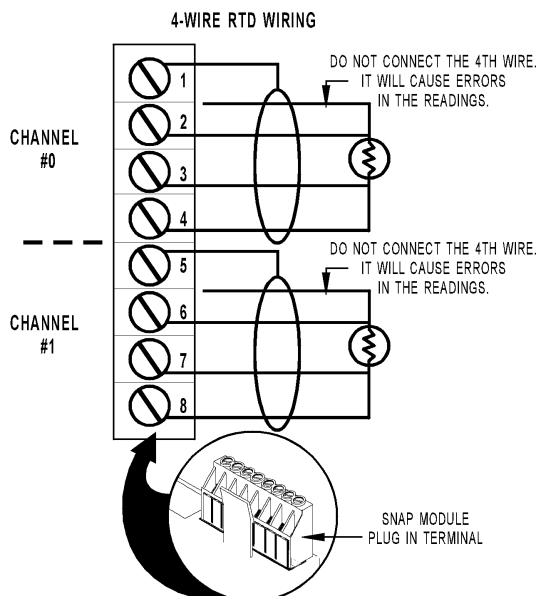
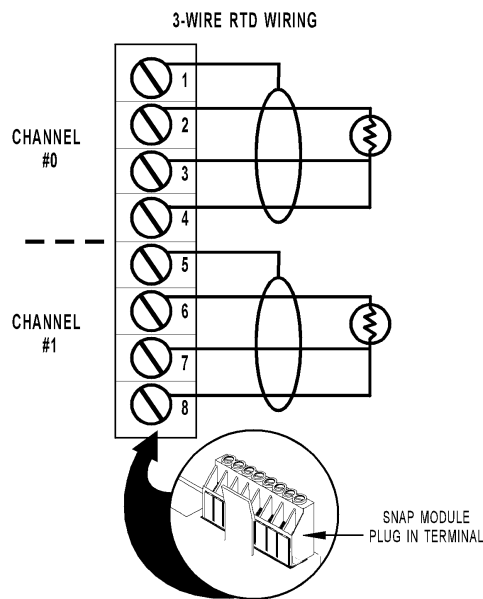

SNAP Analog Input Modules

ICTD Temperature Input Module, Two or Four Channels

SNAP-AICTD (Two channels)

Four-channel module wiring is shown on the next page.

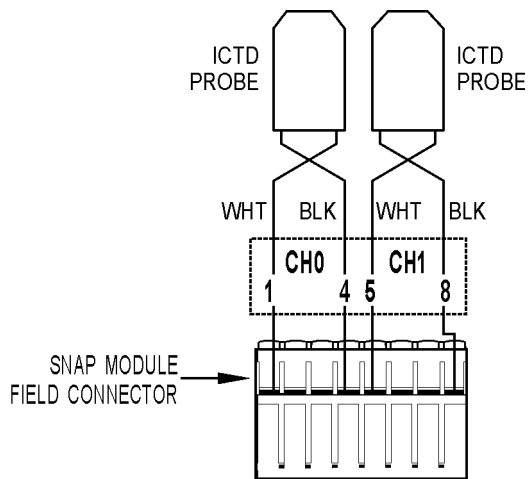

IMPORTANT: The mounting rack connector has 24 pins; the module connector has 20 pins. The extra pins on the mounting rack connector prevent misalignment of the module during installation.



Part Number	Description
SNAP-AICTD	Two-channel analog temperature input, ICTD
SNAP-AICTD-4	Four-channel analog temperature input, ICTD

Description

SNAP-AICTD and SNAP-AICTD-4 modules provide temperature input data from any industry-standard Integrated Circuit Temperature Device (ICTD). The SNAP-AICTD has two channels, and the SNAP-AICTD-4 has four channels. See the table on [page 3](#) for I/O processor compatibility.

The simple two-wire connections are made to the pluggable terminal strip on top of the module. Up to 2,000 feet of ordinary hook-up wire is used to connect the sensor to the input terminal strip.

Both modules are compatible with all industry-standard ICTD probes, including the AD-590 family from Analog Devices and Opto 22's part number ICTD.

Specifications

Input Range with ICTD Probe	-40 °C to +100 °C
Module Input Range Zero Scale Full Scale	-273 °C +150 °C
Resolution	0.017 °C
Accuracy with ICTD Probe	±0.8 °C
Sensitivity	1.0 microamps/ °C
Data Freshness (Max)	167 ms (2-channel module) 355 ms (4-channel module)
DC Common Mode Rejection	>-120 dB
AC Common Mode Rejection	>-120 dB @ 60 Hz
Maximum Operating Common Mode Voltage	250 V
Isolation	1500 V
Power Requirements	5 VDC (± .015) @ 150 mA
Operating Temperature	0 °C to 70 °C
Storage Temperature	-25 °C to 85 °C
Torque, hold-down screws	4 in-lb (0.45 N-m)
Torque, connector screws	5.26 in-lb (0.6 N-m)
Agency Approvals	UL, FM, CE, RoHS, DFARS
Warranty	Lifetime

SNAP Analog Input Modules

ICTD Temperature Input Module (continued)

SNAP-AICTD-4 (Four channels)

Two-channel module wiring is shown on the previous page.

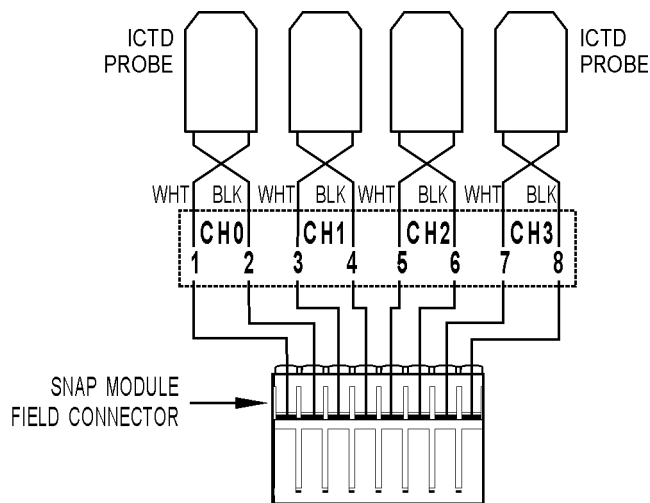

IMPORTANT: The mounting rack connector has 24 pins; the module connector has 20 pins. The extra pins on the mounting rack connector prevent misalignment of the module during installation.

SNAP Analog Input Modules

ICTD Temperature Input Module, Eight Channels

SNAP-AICTD-8

ICTD Source

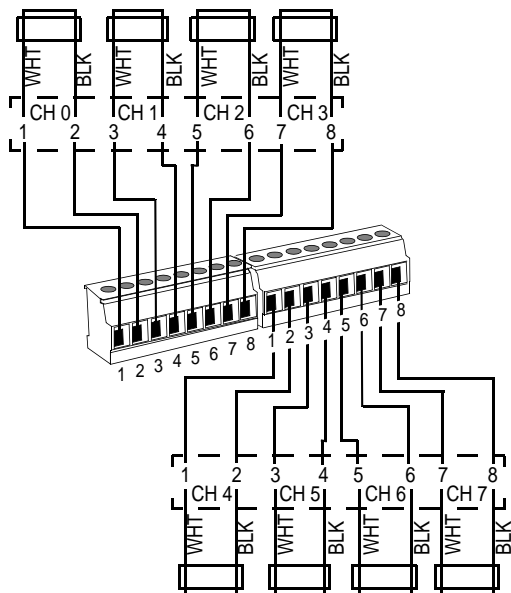

NOTE: Terminals 2, 4, 6, and 8 on both connectors are connected internally.



Part Number	Description
SNAP-AICTD-8	Eight-channel analog temperature input, ICTD

Description

The SNAP-AICTD-8 module provides temperature input data from any industry-standard Integrated Circuit Temperature Device (ICTD). It has eight channels of input. The SNAP-AICTD-8 can be used only with SNAP PAC brains and rack-mounted controllers (standard wired and Wired+Wireless models).

The simple two-wire connections are made to the terminal strip on top of the module. Up to 2,000 feet of ordinary hook-up wire is used to connect the sensor to the input terminal strip.

The module is compatible with all industry-standard ICTD probes, including the AD-590 family from Analog Devices and Opto 22's part number ICTD.

Specifications

Input Range with ICTD Probe	-40 °C to +100 °C
Module Input Range	
Zero Scale	-273 °C
Full Scale	+150 °C
Data Freshness (Max)	0.28 seconds
Resolution	0.017 °C
Accuracy with ICTD Probe	±0.8 °C
Sensitivity	1.0 mA/ °C
DC Common Mode Rejection	>-120 dB
AC Common Mode Rejection	>-120 dB @ 60 Hz
Maximum Operating Common Mode Voltage	250 V
Isolation	1500 V
Power Requirements	5 VDC (± .015) @ 170 mA
Operating Temperature	0 °C to 70 °C
Storage Temperature	-25 °C to 85 °C
Torque, hold-down screws	4 in-lb (0.45 N-m)
Torque, connector screws	5.26 in-lb (0.6 N-m)
Agency Approvals	CE, RoHS, DFARS
Warranty	Lifetime

SNAP Analog Input Modules

Thermocouple/Millivolt Input Module

SNAP-AITM

Thermocouple Polarity and Range

Type	-	+	Range
E	Red	Purple	-270°C to +1,000 °C
J	Red	White	-210°C to +1,200 °C
K	Red	Yellow	-270°C to +1,372 °C

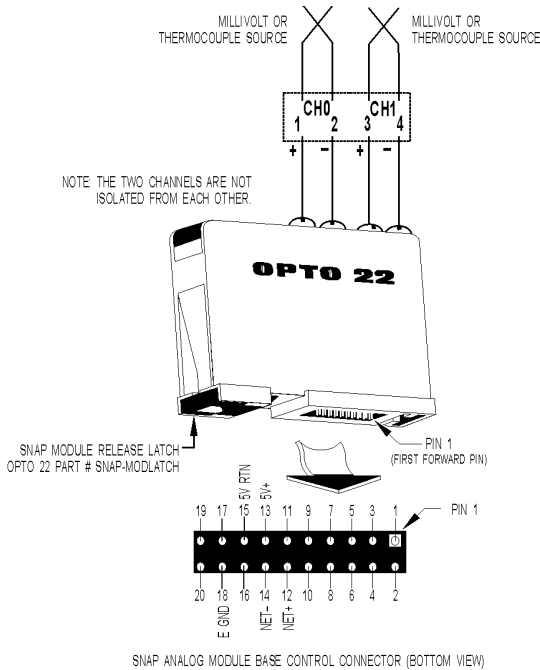

IMPORTANT: The mounting rack connector has 24 pins; the module connector has 20 pins. The extra pins on the mounting rack connector prevent misalignment of the module during installation.

Description

The SNAP-AITM module provides two channels of analog to digital conversion. Each channel on the module can be configured for -150 mV DC to +150 mV DC or -75 mV DC to +75 mV DC, or for type E, J, or K thermocouple operation.

Since both inputs share the same reference terminal, use isolated probes for thermocouple inputs. If you need isolated channels on the same module, see Opto 22 form #1182.

Part Number	Description
SNAP-AITM	Two-channel analog type E, J, or K thermocouple or -150 mV to +150 mV input or -75 mV to +75 mV input

Specifications

Input Range	From -150 mV to +150 mV From -75 mV to +75 mV
Over-Range Limits	From -165 to +165 mV (+/-150 mV range) From -82.5 to +82.5 mV (+/-75 mV range)
Resolution	6 microvolts from -150 to +150 mV 3 microvolts from -75 to +75 mV
Cold Junction Temperature Compensation	Automatic when used with SNAP I/O processors
Input Filtering	-3 dB @ 7 Hz
Input Response Time (% of span/delta V/delta time)	63.2%/95 mV/23 ms
Data Freshness (Max)	167 ms (+/-150 mV) 334 ms (+/-75 mV)
DC Common Mode Rejection	>-120 dB
AC Common Mode Rejection	>-120 dB @ 60 Hz
Maximum Survivable Input	±15 volts
Maximum Operating Common Mode Voltage	250 V
Accuracy at Full Scale	0.06% (90 microvolts) @ 150 mV 0.1% (75 microvolts) @ 75 mV
Drift: Gain Temperature Coefficient	5 microvolts / °C
Drift: Offset Temperature Coefficient	2 microvolts / °C
Thermocouple Accuracy [°C] From factory After user gain and offset commands	± 2.0 (E, J, and K) ± 0.8
Isolation	1500 V
Power Requirements	5 VDC (±0.15) @ 170 mA
Input Resistance	100 Megohms (each channel)
Ambient Temperature: Operating Storage	0 °C to 70 °C -25 °C to 85 °C
Torque, hold-down screws	4 in-lb (0.45 N-m)
Torque, connector screws	5.26 in-lb (0.6 N-m)
Agency Approvals	FM, CE, RoHS, DFARS
Warranty	Lifetime

Thermocouple/Millivolt Input Module

SNAP-AITM-2

Thermocouple Polarity and Range

Type	-	+	Range
B	RED	GRAY	+42° C to +1,820 °C
C, D, G	RED	WHITE	0° C to +2,320 °C
N	RED	ORANGE	-270° C to +1,300 °C
R, S	RED	BLACK	-50° C to +1,768 °C
T	RED	BLUE	-270° C to +400 °C

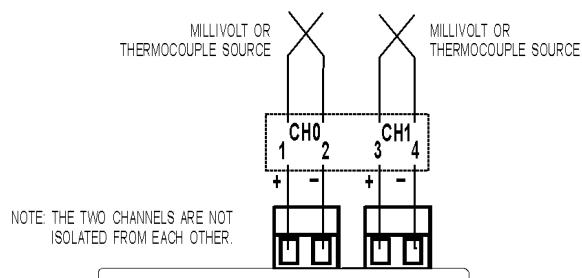

IMPORTANT: The mounting rack connector has 24 pins; the module connector has 20 pins. The extra pins on the mounting rack connector prevent misalignment of the module during installation.

Description

The SNAP-AITM-2 module provides an input range of ± 50 mV, ± 25 mV, or Type B, C, D, G, N, T, R, or S thermocouple.

Since both inputs share the same reference terminal, use isolated probes for thermocouple inputs. If you need isolated channels on the same module, see Opto 22 form #1182.



SNAP Analog Input Modules

Part Number	Description
SNAP-AITM-2	Two-channel analog type B, C, D, G, N, T, R, or S thermocouple or -50 mV to +50 mVDC input or -25 mV to +25 mVDC input

Specifications

Input Range	From -50 mV to +50 mVDC From -25 mV to +25 mVDC
Over-range Limits	From -55 to +55 mV (+/-50 mV range) From -27.5 to +27.5 mV (+/-25 mV range)
Resolution	2 microvolts from -50 mV to +50 mV 1 microvolts from -25 mV to +25 mV
Cold Junction Temperature Compensation	Automatic when used with SNAP brains
Input Filtering	-3 dB @ 2.4 Hz
Input Response Time (% of span/delta V/delta time)	63.2%/31.5 mV/66 ms
Data Freshness (Max)	167 ms (+/- 50 mV) 334 ms (+/- 25 mV)
DC Common Mode Rejection	>-120 dB
AC Common Mode Rejection	>-120 dB @ 60 Hz
Maximum Survivable Input	± 15 volts
Maximum Operating Common Mode Voltage	250 V
Accuracy at Full Scale	0.1% (50 microvolts) @ 50 mV 0.2% (50 microvolts) @ 25 mV
Drift: Gain Temperature Coefficient	5 microvolts / °C
Drift: Offset Temperature Coefficient	2 microvolts / °C
Thermocouple Accuracy [°C]	B, R, S C, D, G T, N
From factory	± 5 ± 4 ± 3
After user gain and offset commands	± 3 ± 2 ± 2
Isolation	1500 V
Power Requirements	5 VDC (± 0.15) @ 170 mA
Input Resistance	100 Megohms (each channel)
Ambient Temperature: Operating Storage	0 °C to 70 °C -25 °C to 85 °C
Agency Approvals	FM, CE, RoHS, DFARS
Torque, hold-down screws	4 in-lb (0.45 N-m)
Torque, connector screws	5.26 in-lb (0.6 N-m)
Warranty	Lifetime

SNAP Analog Input Modules

Thermocouple/Millivolt Input Module

SNAP-AITM-8 and SNAP-AITM-8-FM

Thermocouple Polarity and Range

Type	-	+	Range
B	RED	GRAY	+42° C to +1,820 °C
C, D, G	RED	WHITE	0° C to +2,320 °C
E	RED	PURPLE	-270°C to +1,000 °C
J	RED	WHITE	-210°C to +1,200 °C
K	RED	YELLOW	-270°C to +1,372 °C
N	RED	ORANGE	-270° C to +1,300 °C
R, S	RED	BLACK	-50° C to +1,768 °C
T	RED	BLUE	-270° C to +400 °C

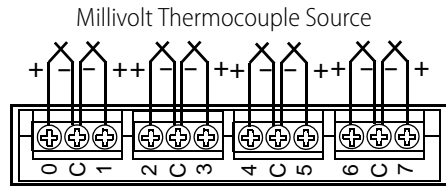

Common terminals are connected internally.

NOTE: For best accuracy, wire all points before calibrating, and short all unused channels.

The SNAP-AITM-8-FM is Factory Mutual approved.



Description

The SNAP-AITM-8 and SNAP-AITM-8-FM modules provide eight channels of analog to digital conversion. Each channel on the module can be configured for -75 mV DC to +75 mV DC, -50 mV DC to +50 mV DC, -25 mV DC to +25 mV DC, or for type B, C, D, E, G, J, K, N, R, S or T thermocouple operation.

Since all inputs share the same reference terminal, use isolated probes for thermocouple inputs. See the dimensional diagram on [page 33](#).

Part Number	Description
SNAP-AITM-8 SNAP-AITM-8-FM	8-channel B, C, D, E, G, J, K, N, R, S, or T thermocouple or -75 mV to +75 mV, 50 mV to +50 mV, or 25 mV to +25 mV input

Specifications

Input Range	From -75 mV to +75 mV From -50 mV to +50 mV From -25 mV to +25 mV
Over-Range Limits	From -82.5 to +82.5 mV (+/-75 mV range) From -55 to +55 mV (+/-50 mV range) From -27.5 to +27.5 mV (+/-25 mV range)
Resolution	3 microvolts from -75 mV to +75 mV 2 microvolts from -50 mV to +50 mV 1 microvolts from -25 mV to +25 mV
Cold Junction Temperature Compensation	Automatic when used with SNAP I/O processors
Input Filtering	-3 dB @ 5 Hz
Data Freshness (Max)	2.25 s
DC Common Mode Rejection	>-120 dB
AC Common Mode Rejection	>-120 dB @ 60 Hz
Maximum Survivable Input	±15 volts
Max Operating Common Mode Voltage	250 V
Accuracy at Full Scale	0.1% (75 microvolts) @ 75 mV 0.1% (50 microvolts) @ 50 mV 0.2% (50 microvolts) @ 25 mV
Drift: Gain Temperature Coefficient	5 microvolts / °C
Drift: Offset Temperature Coefficient	2 microvolts / °C
Thermocouple Accuracy [°C]	E, J, K B, R, S C, D, G T, N
From factory	±2.0 ±5 ±4 ±3
After user gain and offset commands	±0.5 ±3 ±2 ±2
Isolation	1500 V
Power Requirements	5 VDC (±0.15) @ 200 mA
Input Resistance	100 Megohms (each channel)
Ambient Temperature: Operating Storage	0 °C to 70 °C -25 °C to 85 °C
Torque, hold-down screws	4 in-lb (0.45 N-m)
Torque, connector screws	5.26 in-lb (0.6 N-m)
Agency Approvals	SNAP-AITM-8: UL, CE, RoHS, DFARS SNAP-AITM-8-FM: FM, CE, RoHS, DFARS
Warranty	Lifetime

0 to 250 Volt RMS AC/DC Input Module

SNAP-AIVRMS

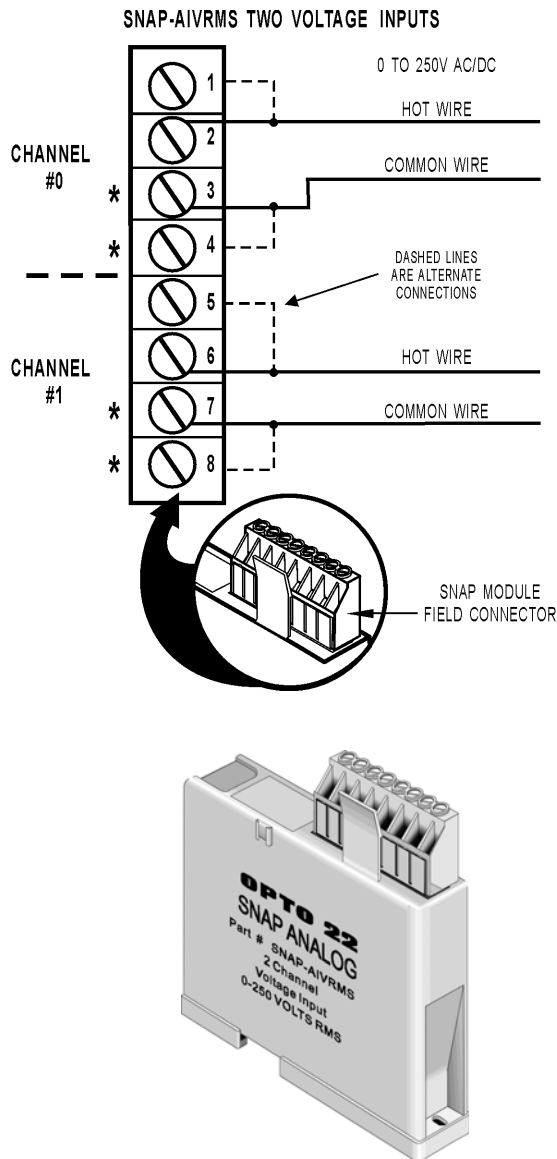

SNAP Analog Input Modules

Part Number	Description
SNAP-AIVRMS	Two-channel 0 to 250 V RMS AC/DC input

Description

The SNAP-AIVRMS module provides an input range of 0 to 250 volts AC or DC. The SNAP-AIVRMS module may be used to monitor 120/240-volt AC/DC and 12/24/48-volt AC/DC system voltage.

Terminals 3, 4, 7, and 8 share a common connection inside the module. Make sure you observe polarity when connecting the second channel. To avoid a potentially hazardous short, double-check wiring before turning on the voltage to be monitored.

If you need a module with channel-to-channel isolation, see form #1182, the *SNAP Isolated Analog Input Modules Data Sheet*.

Specifications

Input Range	0 to 250 V RMS AC/DC
Input Over-Range	To 275 V
Input Resistance	1 M ohms
Accuracy	± 0.2 V and $\pm 0.2\%$ reading
Resolution	10 mV
DC Reversal	± 0.4 V (.16%)
Input Response Time (Step Change)	5% (12.5 V) in 100 mS 63.2% (158 V) in 200 mS 99% (248 V) in 1200 mS
Data Freshness (Max)	32.3 ms
DC Common Mode Rejection	> -120 dB
AC Common Mode Rejection	> -120 dB @ 60 Hz
Maximum Operating Common Mode Voltage	250 V
Isolation	1500 V
Power Requirements	5 VDC (± 0.15 V) at 170 mA
Operating Temperature	0 °C to 70 °C
Storage Temperature	-25 °C to 85 °C
Torque, hold-down screws	4 in-lb (0.45 N-m)
Torque, connector screws	5.26 in-lb (0.6 N-m)
Agency Approvals	UL, FM, CE, RoHS, DFARS
Warranty	Lifetime

SNAP Analog Input Modules

Voltage Input Module, -10 VDC to +10 VDC or -5 VDC to +5 VDC, Two or Four Channels

SNAP-AIV (Two channels)

Four-channel module wiring is shown on [page 24](#).

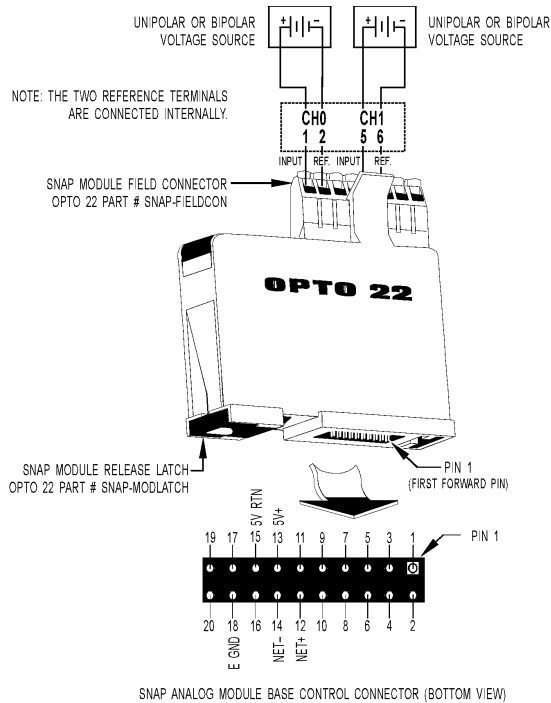

IMPORTANT: The mounting rack connector has 24 pins; the module connector has 20 pins. The extra pins on the mounting rack connector prevent misalignment of the module during installation.

Description

The SNAP-AIV and SNAP-AIV-4 modules can be configured for either -10 VDC to +10 VDC or -5 VDC to +5 VDC operation on each channel. The SNAP-AIV provides two channels, and the SNAP-AIV-4 four. If you need a module with more channels, see [page 25](#). See the table on [page 3](#) for I/O processor compatibility.

Note that all channels share a common reference terminal. If you need two isolated channels on the same module, see Opto22 form #1182.

Part Number	Description
SNAP-AIV	Two-channel analog voltage input -10 to +10 VDC
SNAP-AIV-4	Four-channel analog voltage input -10 to +10 VDC

Specifications

Input Range	From -10 volts to +10 volts From -5 volts to +5 volts
Over-Range Limits	From -11 to +11 volts (+/-10 V range) From -5.5 to +5.5 volts (+/-5 V range)
Resolution	0.4 mV when configured -10 to +10 volts 0.2 mV when configured -5 to +5 volts
Input Filtering	-3 dB @ 64 Hz
Input Response Time (% of span/ delta V / delta t)	63.2% / 6.7 V / 10 ms
Data Freshness (Max)	11.5 ms (2-channel, +/- 10 VDC) 23 ms (2-channel, +/- 5 VDC) 23 ms (4-channel, +/- 10 VDC) 46 ms (4-channel, +/- 5 VDC)
DC Common Mode Rejection	>-120 dB
AC Common Mode Rejection	>-120 dB @ 60 Hz
Maximum Survivable Input	220 VAC or 300 VDC
Maximum Operating Common Mode Voltage	250 V
Accuracy	0.05%, 5 mV @ 10 VDC 2.5 mV @ 5 VDC
Gain Temperature Coefficient	30 PPM/ °C
Offset Temperature Coefficient	15 PPM/ °C
Isolation	1500 V
Power Requirements	5 VDC (±0.15) @ 170 mA
Input Resistance	1 M ohms (each channel; both channels share the same reference point)
Ambient Temperature: Operating Storage	0 °C to 70 °C -25 °C to 85 °C
Torque, hold-down screws	4 in-lb (0.45 N-m)
Torque, connector screws	5.26 in-lb (0.6 N-m)
Agency Approvals	UL, FM, CE, RoHS, DFARS
Warranty	Lifetime

SNAP Analog Input Modules

Voltage Input Module, -10 VDC to +10 VDC or -5 VDC to +5 VDC, Four Channels (continued)

SNAP-AIV-4 (Four channels)

Two-channel module wiring is shown on the previous page.

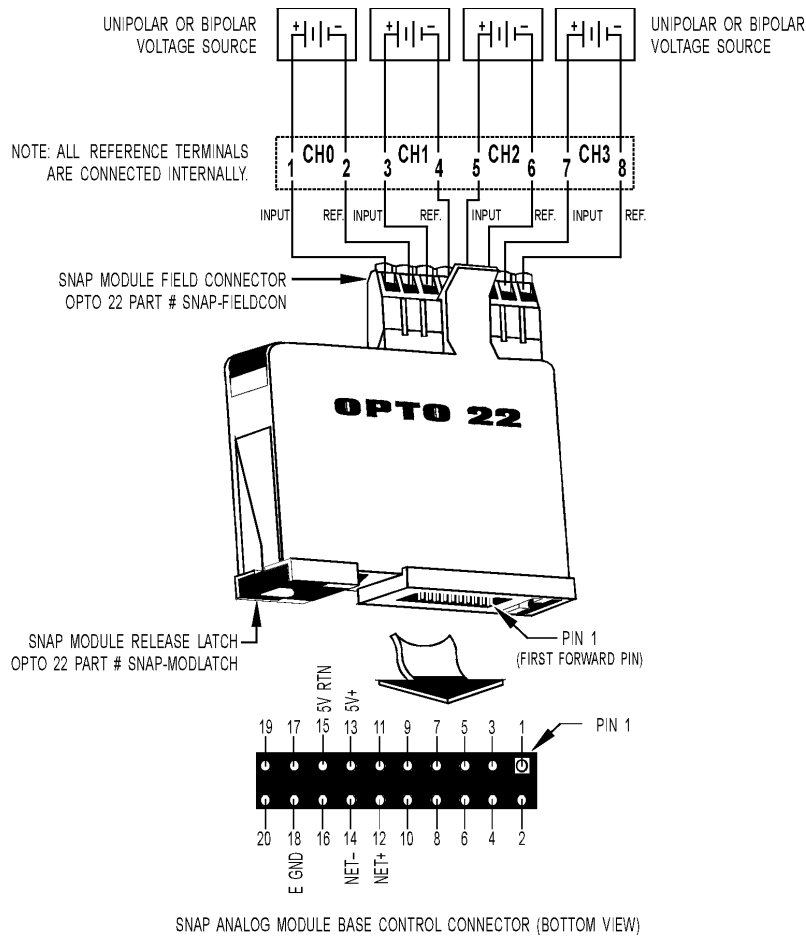

IMPORTANT: The mounting rack connector has 24 pins; the module connector has 20 pins. The extra pins on the mounting rack connector prevent misalignment of the module during installation.

SNAP Analog Input Modules

Voltage Input Module, -10 VDC to +10 VDC or -5 VDC to +5 VDC, Eight Channels

SNAP-AIV-8

Voltage Source

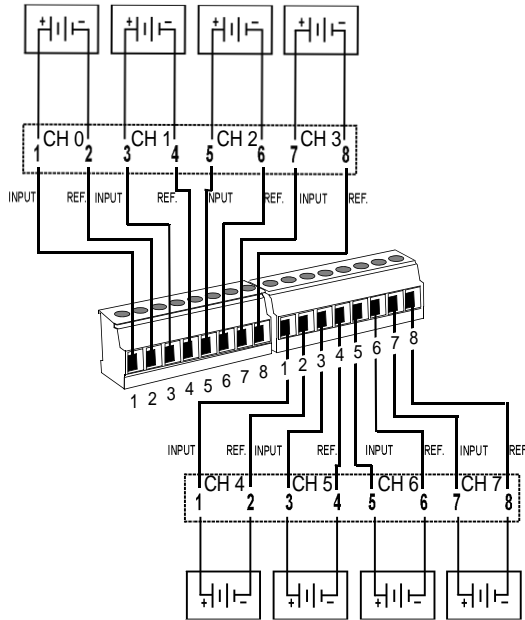

NOTE: Terminals 2, 4, 6, and 8 on both connectors are connected internally.

Description

The SNAP-AIV-8 module can be configured for either -10 VDC to +10 VDC or -5 VDC to +5 VDC operation on each of its eight input channels. (If you need a module with more channels, see [page 26](#).) The SNAP-AIV-8 can be used only with SNAP PAC brains and rack-mounted controllers (standard wired and Wired+Wireless models).



Part Number	Description
SNAP-AIV-8	Eight-channel analog voltage input -10 to +10 VDC

Note that all channels share a common reference terminal. If you need two isolated channels on the same module, see Opto22 form #1182.

Specifications

Input Range	From -10 volts to +10 volts From -5 volts to +5 volts
Over-Range Limits	From -11 to +11 volts (+/-10 V range) From -5.5 to +5.5 volts (+/-5 V range)
Resolution	0.4 mV when configured -10 to +10 volts 0.2 mV when configured -5 to +5 volts
Input Filtering	-3 dB @ 64 Hz
Data Freshness (Max)	0.28 seconds
DC Common Mode Rejection	>-120 dB
AC Common Mode Rejection	>-120 dB @ 60 Hz
Maximum Survivable Input	220 VAC or 300 VDC
Maximum Operating Common Mode Voltage	250 V
Accuracy	0.05%, 5 mV @ 10 VDC 2.5 mV @ 5 VDC
Gain Temperature Coefficient	30 PPM/ °C
Offset Temperature Coefficient	15 PPM/ °C
Isolation	1500 V
Power Requirements	5 VDC (±0.15) @ 170 mA
Input Resistance	1 M ohms (all channels share the same reference point)
Ambient Temperature: Operating Storage	0 °C to 70 °C -25 °C to 85 °C
Torque, hold-down screws	4 in-lb (0.45 N-m)
Torque, connector screws	5.26 in-lb (0.6 N-m)
Agency Approvals	CE, RoHS, DFARS
Warranty	Lifetime

SNAP Analog Input Modules

Voltage Input Module, -10 VDC to +10 VDC or -5 VDC to +5 VDC, 32 Channels

Specifications

Input Range	From -10 volts to +10 volts From -5 volts to +5 volts
Over-Range Limits	From -11 to +11 volts (+/-10 V range) From -5.5 to +5.5 volts (+/-5 V range)
Resolution	0.4 mV when configured -10 to +10 volts 0.2 mV when configured -5 to +5 volts
Input Filtering	-3 dB @ 31 Hz
Data Freshness (Max)	1.1 s
DC Common Mode Rejection	>-120 dB
AC Common Mode Rejection	>-120 dB @ 60 Hz
Maximum Survivable Input	220 VAC or 300 VDC
Maximum Operating Common Mode Voltage	250 V
Accuracy	0.05%, 5 mV @ 10 VDC 2.5 mV @ 5 VDC
Gain Temperature Coefficient	30 PPM/ °C
Offset Temperature Coefficient	15 PPM/ °C
Isolation	1500 V
Power Requirements	5 VDC (±0.15) @ 150 mA
Input Resistance	1 M ohms (each channel; all channels share the same reference point)
Ambient Temperature: Operating Storage	0 °C to 70 °C -25 °C to 85 °C
Torque, hold-down screws	4 in-lb (0.45 N-m)
Torque, connector screws	5.26 in-lb (0.6 N-m)
Agency Approvals	SNAP-AIV-32: UL, CE, RoHS, DFARS SNAP-AIV-32-FM: FM, CE, RoHS, DFARS
Warranty	Lifetime

Part Number	Description
SNAP-AIV-32 SNAP-AIV-32-FM	32-channel analog voltage input -10 to +10 VDC
SNAP-HD-CBF6	Wiring harness with flying leads for SNAP-AIV-32 modules
SNAP-HD-BF6	Wiring harness for SNAP-AIV-32 modules and SNAP-AIV-HDB breakout racks
SNAP-AIV-HDB SNAP-AIV-HDB-FM	Breakout racks for SNAP-AIV-32 and SNAP-AIV-32-FM

Description

The SNAP-AIV-32 and SNAP-AIV-32-FM modules can be configured for either -10 VDC to +10 VDC or -5 VDC to +5 VDC operation on each of its 32 channels. See the table on [page 3](#) for I/O processor compatibility. The SNAP-AIV-32-FM is Factory Mutual approved.

Note that all channels share a common reference terminal. (For channel-to-channel isolated modules, see Opto22 form #1182.)

SNAP TEX cables and a breakout rack are available separately for wiring points to field devices (see form #1756, the *SNAP TEX Cables & Breakout Boards Data Sheet*). The SNAP-HD-BF6 wiring harness connects the module to the breakout rack, which can then be wired to field devices. The SNAP-HD-CBF6 wiring harness has flying leads to connect to field devices.

See the dimensional drawing for the module on [page 35](#).



SNAP Analog Input Modules

Voltage Input Module -10 VDC to +10 VDC or -5 VDC to +5 VDC (continued)

Wiring diagram: SNAP-AIV-HDB breakout rack to SNAP-AIV-32 or SNAP-AIV-32-FM module

NOTE: This diagram is also used to wire the SNAP-AIV-HDB breakout rack to a SNAP-AIMA-32 or SNAP-AIMA-32-FM module, when the module connects to self-powered (4-wire) device.

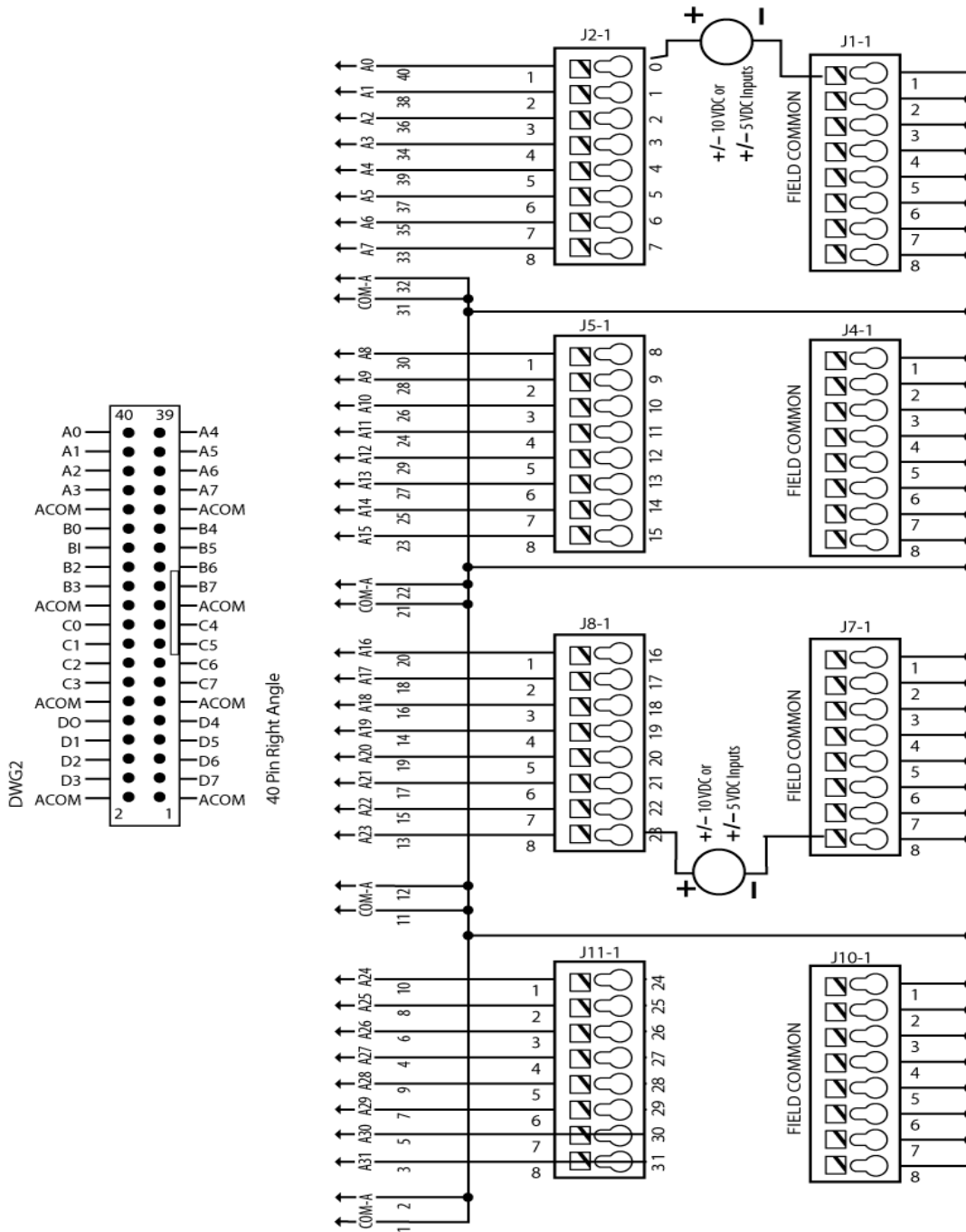

SNAP Analog Input Modules

Millivolt Input Module

SNAP-AIMV2-4

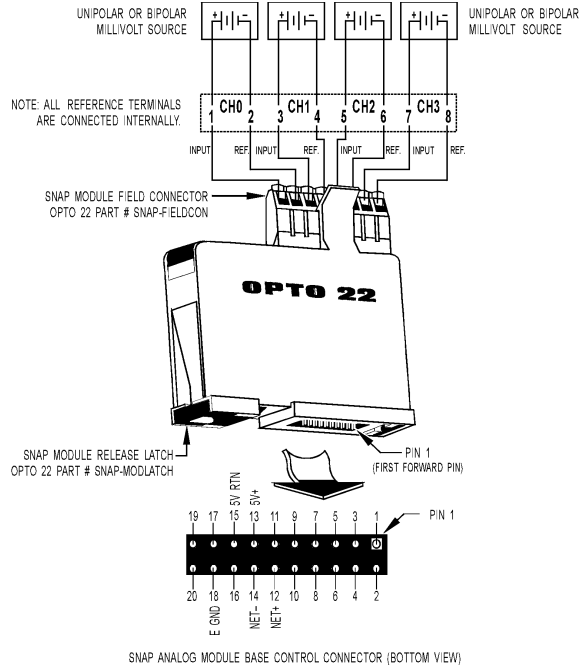

IMPORTANT: The mounting rack connector has 24 pins; the module connector has 20 pins. The extra pins on the mounting rack connector prevent misalignment of the module during installation.

Description

The SNAP-AIMV2-4 module provides four channels of analog to digital conversion. See the table on [page 3](#) for I/O processor compatibility.

Each channel on the module can be configured for -50 mV DC to +50 mV DC or -25 mV DC to +25 mV DC.

Note that all inputs share the same reference terminal.

Part Number	Description
SNAP-AIMV2-4	Four-channel -50 to +50 mV input or -25 mV to +25 mV input

Specifications

Input Range	From -50 mV to +50 mV From -25 mV to +25m V
Over-Range Limits	From -55 to +55 mV (+/-50 mV range) From -27.5 to +27.5 mV (+/-25 mV range)
Resolution	2 microvolts (-50 mV to +50 mV) 1 microvolt (-25 mV to +25 m V)
Input Filtering	-3 dB @ 2.4Hz
Input Response Time (% of span/delta V/delta time)	63.2%/31.5 mV/66 ms
Data Freshness (Max)	335 ms (+/- 50 mV) 668 ms (+/- 25 mV)
DC Common Mode Rejection	>-120 dB
AC Common Mode Rejection	>-120 dB @ 60 Hz
Maximum Survivable Input	±15 volts
Maximum Operating Common Mode Voltage	250 V
Accuracy at Full Scale	0.1% (50 microvolts) @ 50m V 0.2% (50 microvolts) @ 25 mV
Drift: Gain Temperature Coefficient	3 microvolts / °C
Drift: Offset Temperature Coefficient	2 microvolts / °C
Isolation	1500 V
Power Requirements	5 VDC (±0.15) @ 170 mA
Input Resistance - Single Ended	100 Megohms (each channel)
Operating Temperature	0 °C to 70 °C
Storage Temperature	-25 °C to 85 °C
Torque, hold-down screws	4 in-lb (0.45 N-m)
Torque, connector screws	5.26 in-lb (0.6 N-m)
Agency Approvals	UL, FM, CE, RoHS, DFARS
Warranty	Lifetime

SNAP Analog Input Modules

Millivolt Input Module

SNAP-AIMV-4

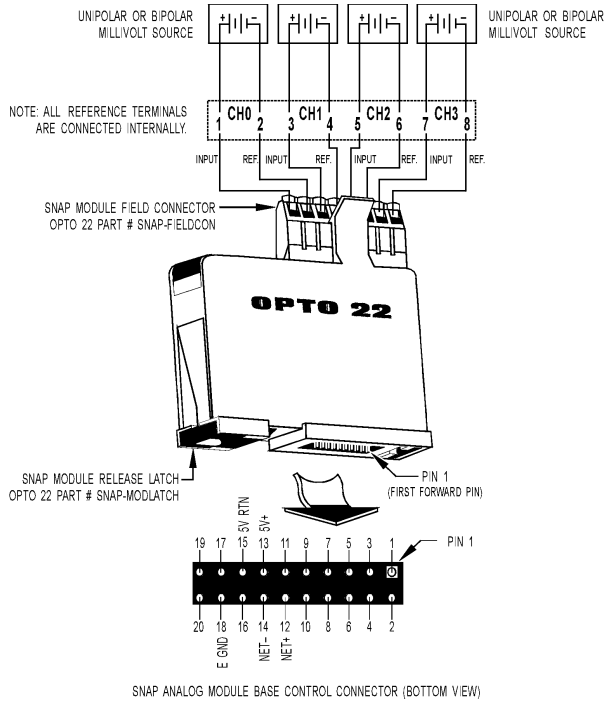

IMPORTANT: The mounting rack connector has 24 pins; the module connector has 20 pins. The extra pins on the mounting rack connector prevent misalignment of the module during installation.

Description

The SNAP-AIMV-4 module provides four channels of analog to digital conversion. See the table on [page 3](#) for I/O processor compatibility.

Each channel on the module can be configured for -150 mV DC to +150 mV DC or -75 mV DC to +75 mV DC.

Note that all inputs share the same reference terminal.

Part Number	Description
SNAP-AIMV-4	Four-channel -150 to +150 mV or -75 to +75 mV input

Specifications

Input Range	From -150 mV to +150 mV From -75 mV to +75m V
Over-Range Limits	From -165 to +165 mV (+/-150 mV range) From -82.5 to +82.5 mV (+/-75 mV range)
Resolution	6 microvolts (-150 mV to +150 mV) 3 microvolts (-75 mV to +75 mV)
Input Filtering	-3 dB @ 7 Hz
Input Response Time (% of span/delta V/delta time)	63.2%/95 mV/23 ms
Data Freshness (Max)	335 ms (+/- 150 mV) 668 ms (+/- 75 mV)
DC Common Mode Rejection	>-120 dB
AC Common Mode Rejection	>-120 dB @ 60 Hz
Maximum Survivable Input	±15 volts
Maximum Operating Common Mode Voltage	250 V
Accuracy at Full Scale	0.06% (90 microvolts) @ 150 mV 0.1% (75 microvolts) @ 75 mV
Drift: Gain Temperature Coefficient	3 microvolts / °C
Drift: Offset Temperature Coefficient	2 microvolts / °C
Isolation	1500 V
Power Requirements	5 VDC (±0.15) @ 170 mA
Input Resistance - Single Ended	100 Megohms (each channel)
Operating Temperature	0 °C to 70 °C
Storage Temperature	-25 °C to 85 °C
Torque, hold-down screws	4 in-lb (0.45 N-m)
Torque, connector screws	5.26 in-lb (0.6 N-m)
Agency Approvals	UL, FM, CE, RoHS, DFARS
Warranty	Lifetime

SNAP Analog Input Modules

Alternate Wiring Diagram

SNAP-AIV-HDB breakout rack to SNAP-AIMA-32 or SNAP-AIMA-32-FM module when the module connects to devices that share a positive common connection

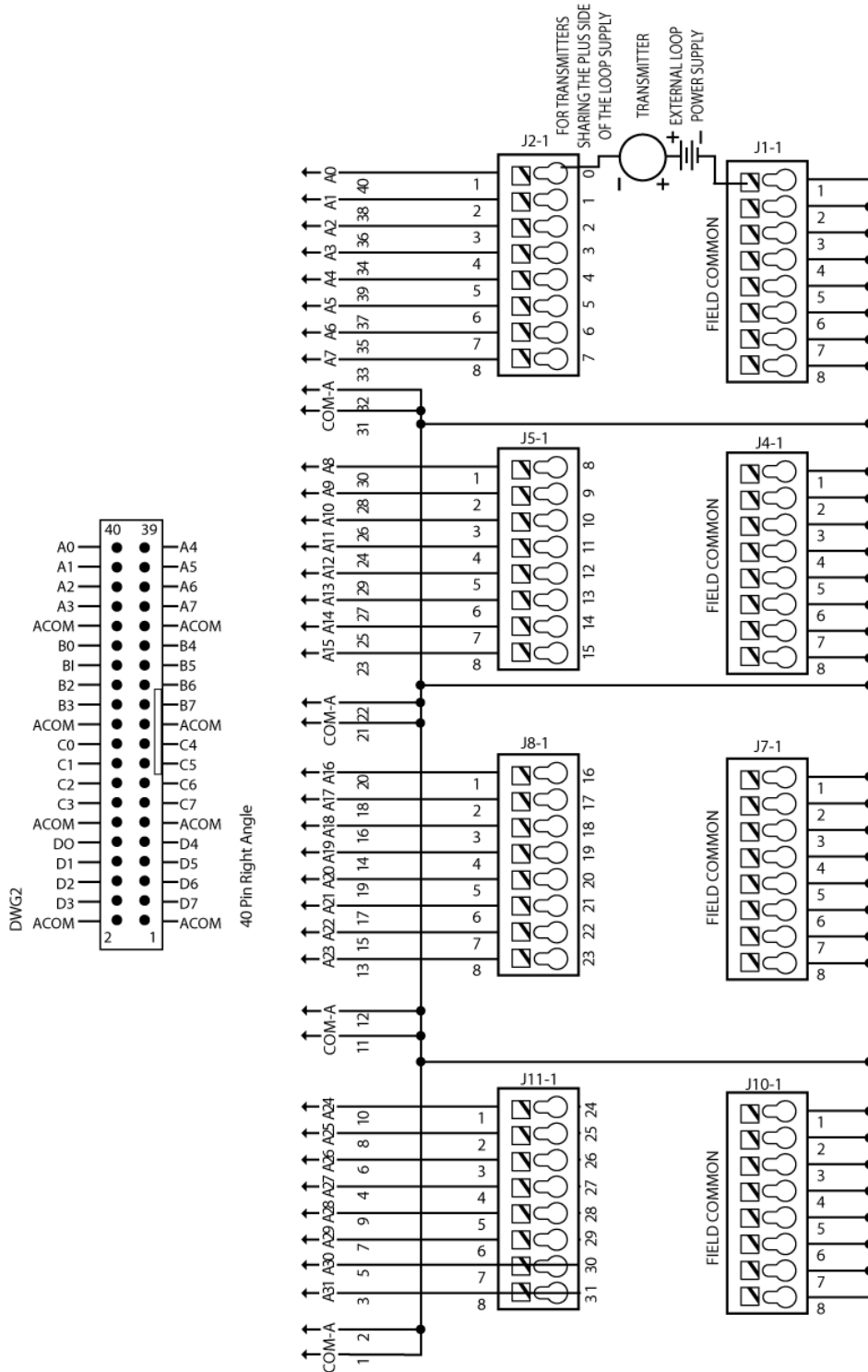

SNAP Analog Input Modules

Dimensional Drawing

All Two- and Four-channel Modules, except SNAP-AITM-2

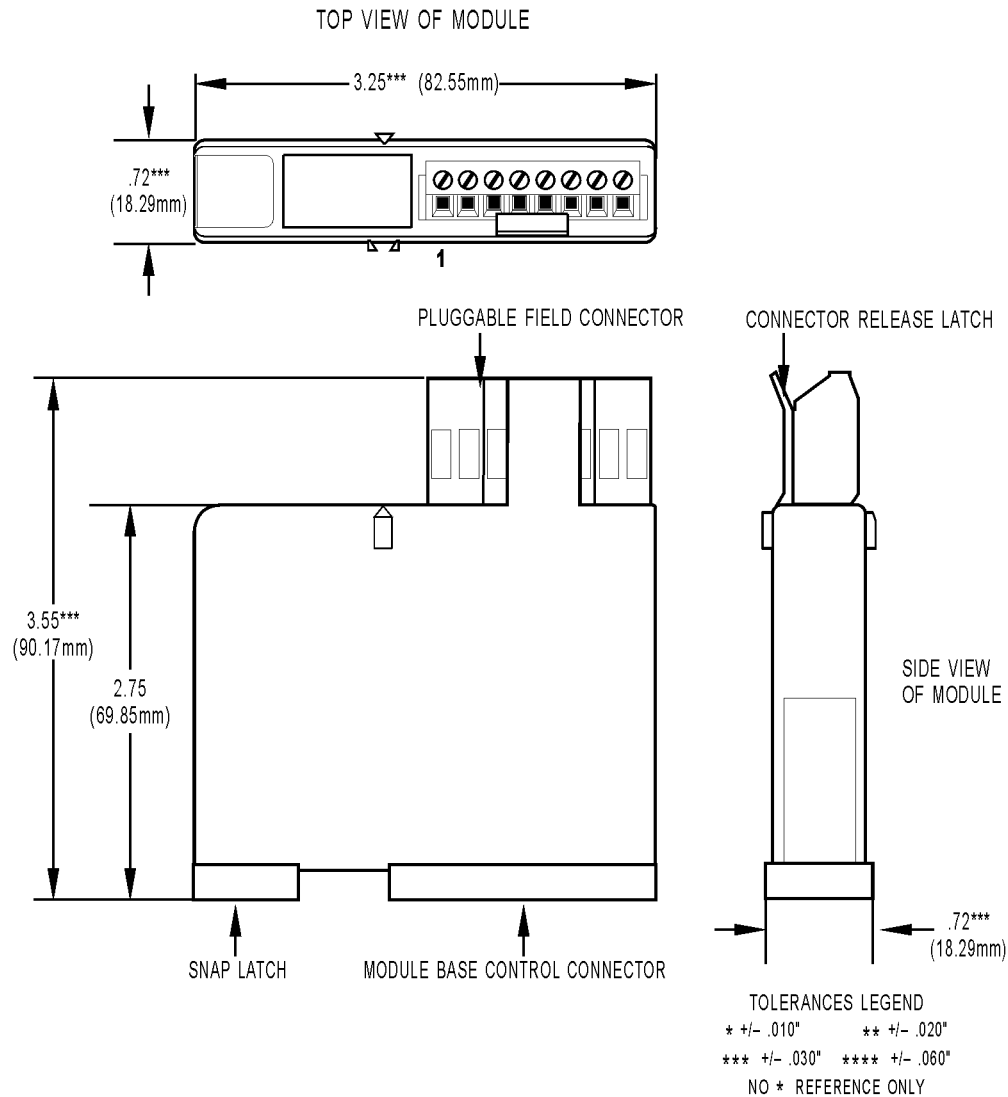

SNAP Analog Input Modules

Dimensional Drawing

SNAP-AITM-2 Modules

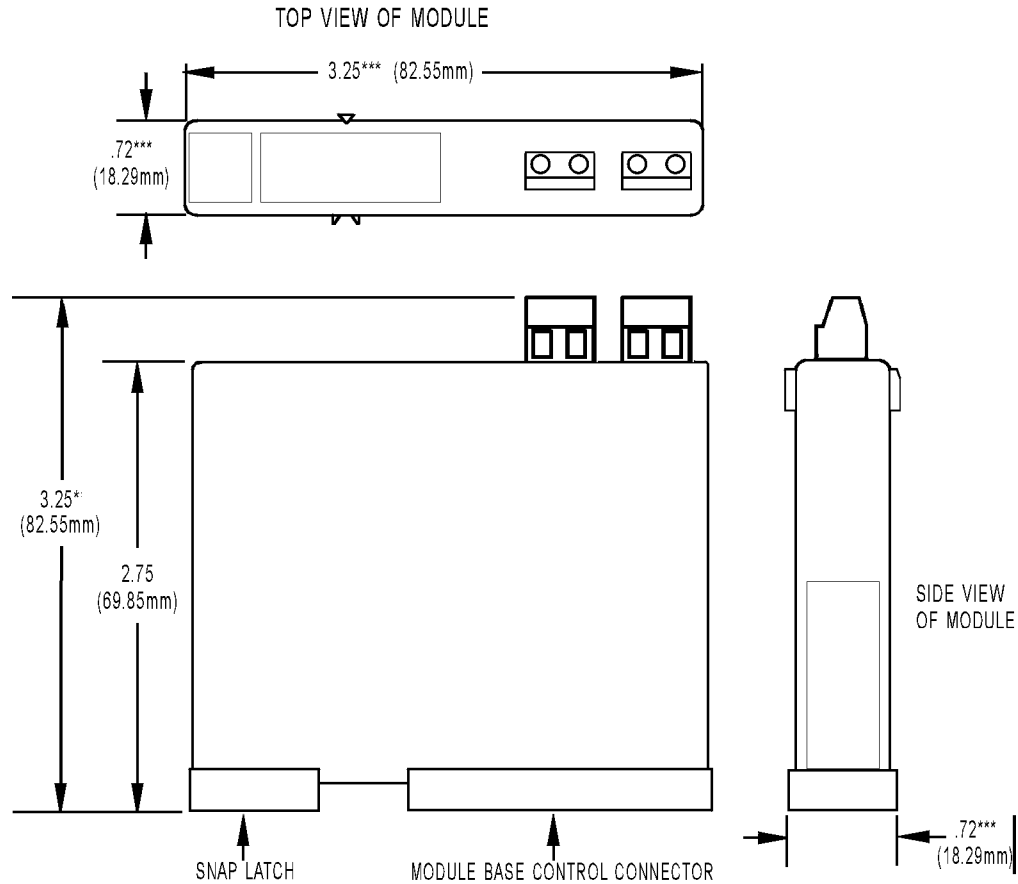

TOLERANCES LEGEND
 * +/- .010" ** +/- .020"
 *** +/- .030" **** +/- .060"
 NO * REFERENCE ONLY

SNAP Analog Input Modules

Dimensional Drawing

SNAP-AITM-8 and SNAP-AITM-8-FM Modules

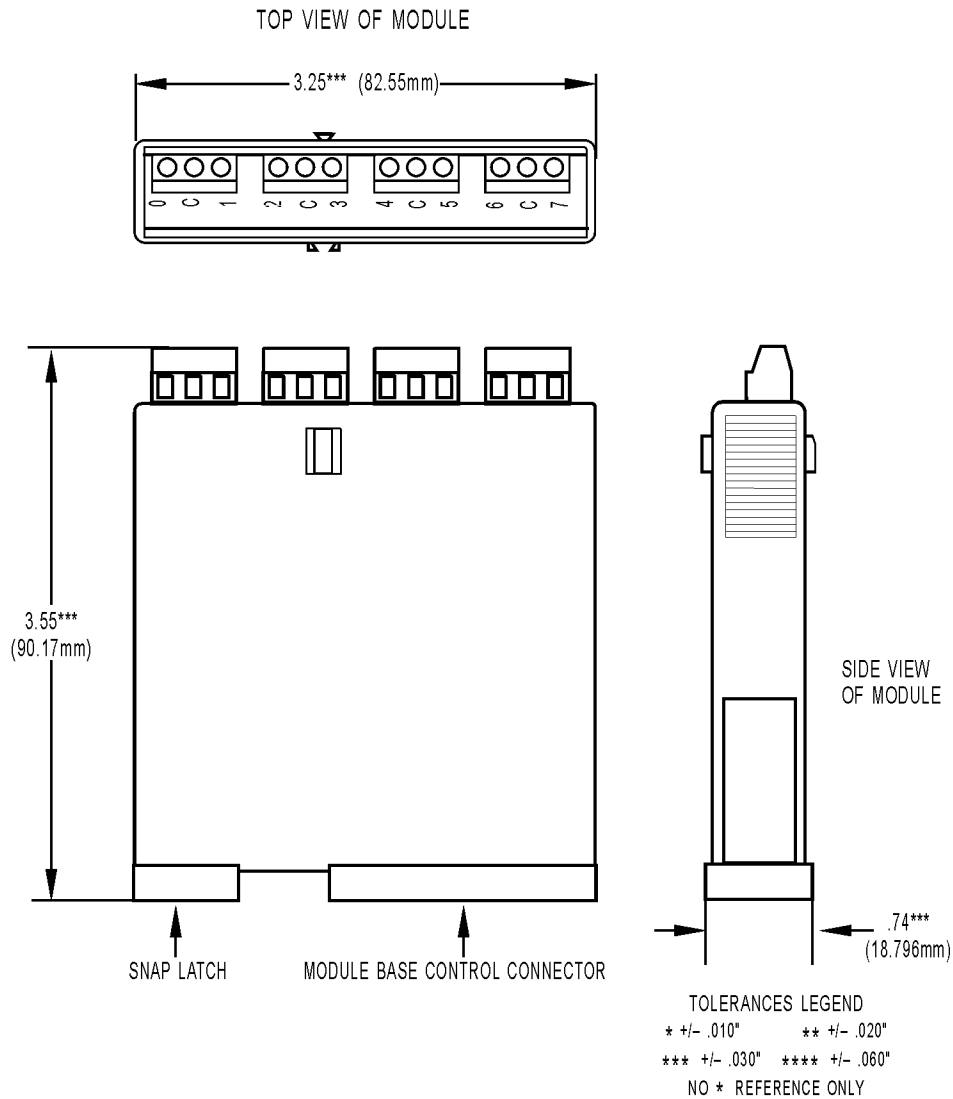

SNAP Analog Input Modules

Dimensional Drawing

SNAP-AICTD-8, SNAP-AIMA-8, and SNAP-AIV-8 Modules

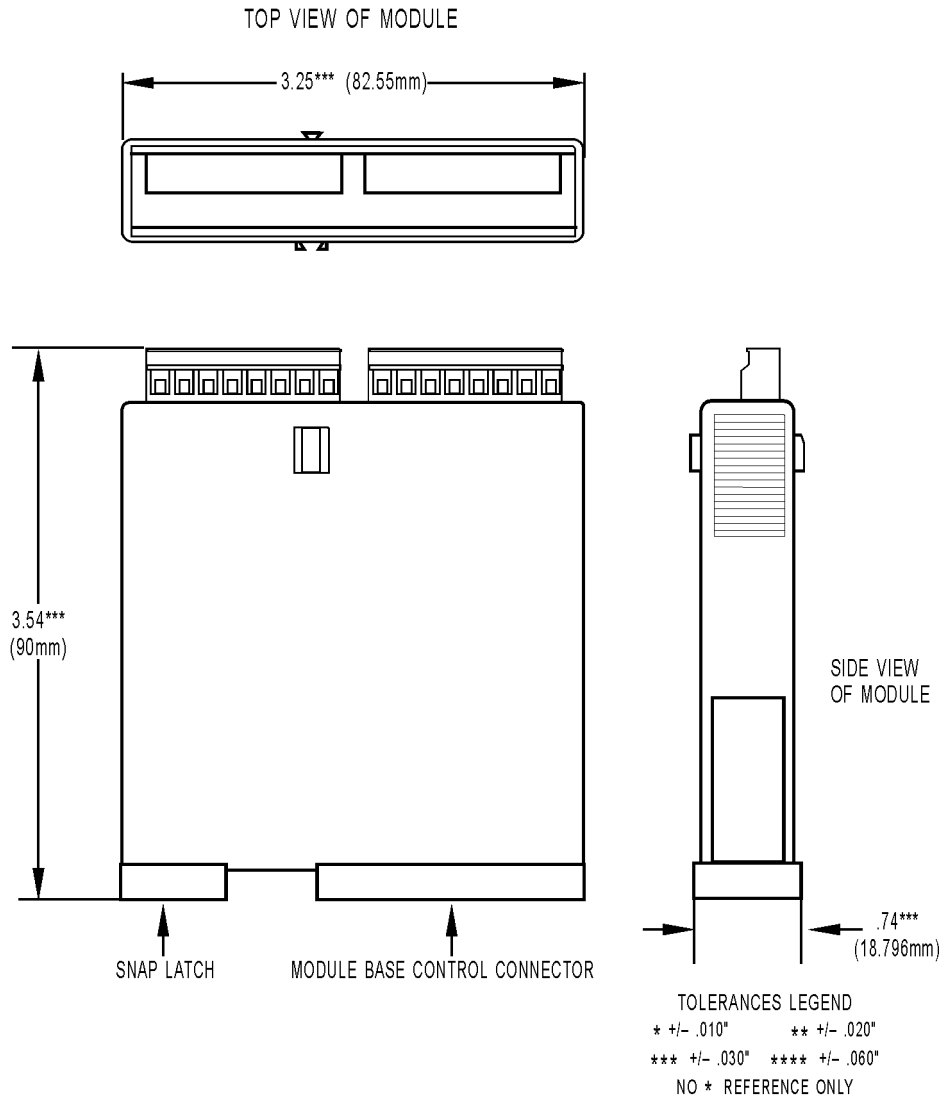

SNAP Analog Input Modules

Dimensional Drawing

SNAP-AIMA-32, SNAP-AIMA-32-FM, SNAP-AIV-32, and SNAP-AIV-32-FM Modules

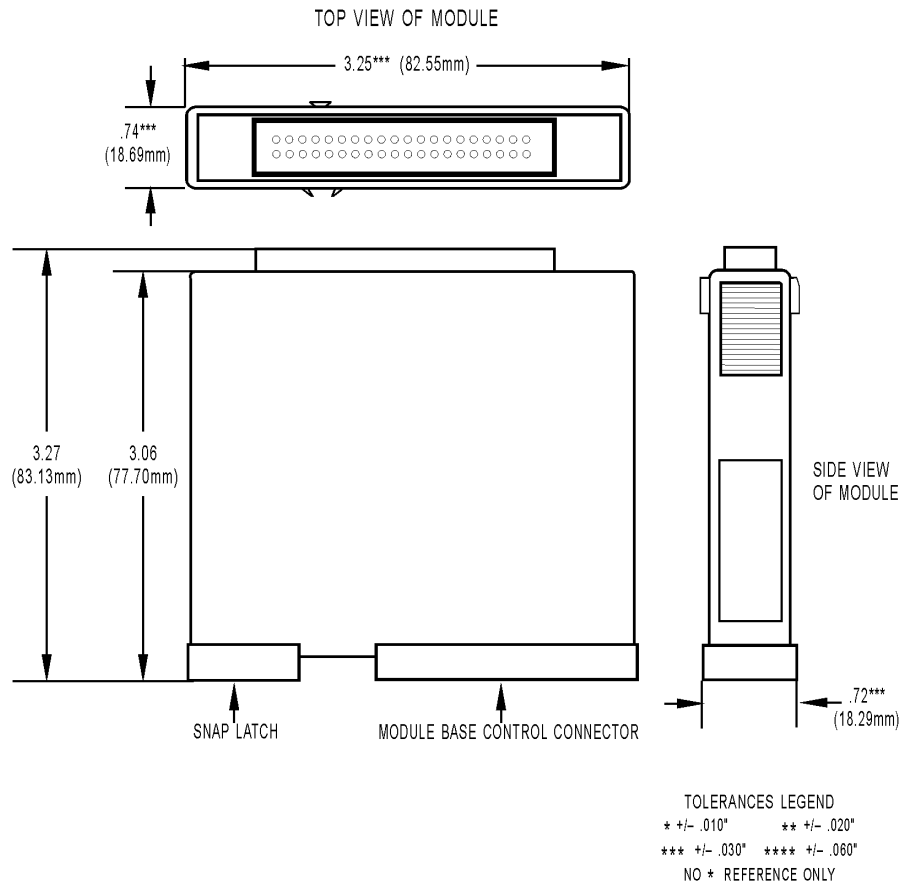

SNAP Analog Input Modules

Dimensional Drawing

All Modules

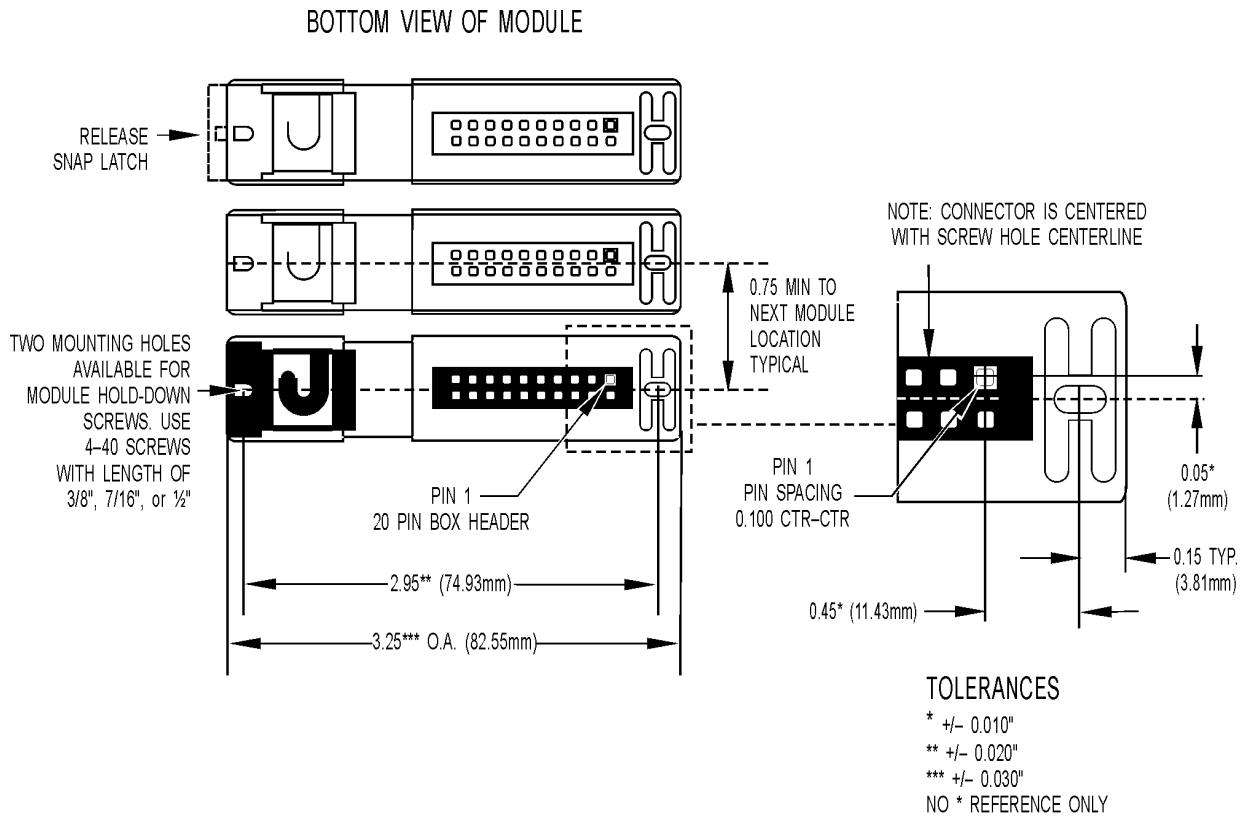

IMPORTANT: The mounting rack connector has 24 pins; the module connector has 20 pins. The extra pins on the mounting rack connector prevent misalignment of the module during installation.

SNAP Analog Input Modules

Dimensional Drawing

Height on Rack: All Two- and Four-channel Modules, except SNAP-AITM-2

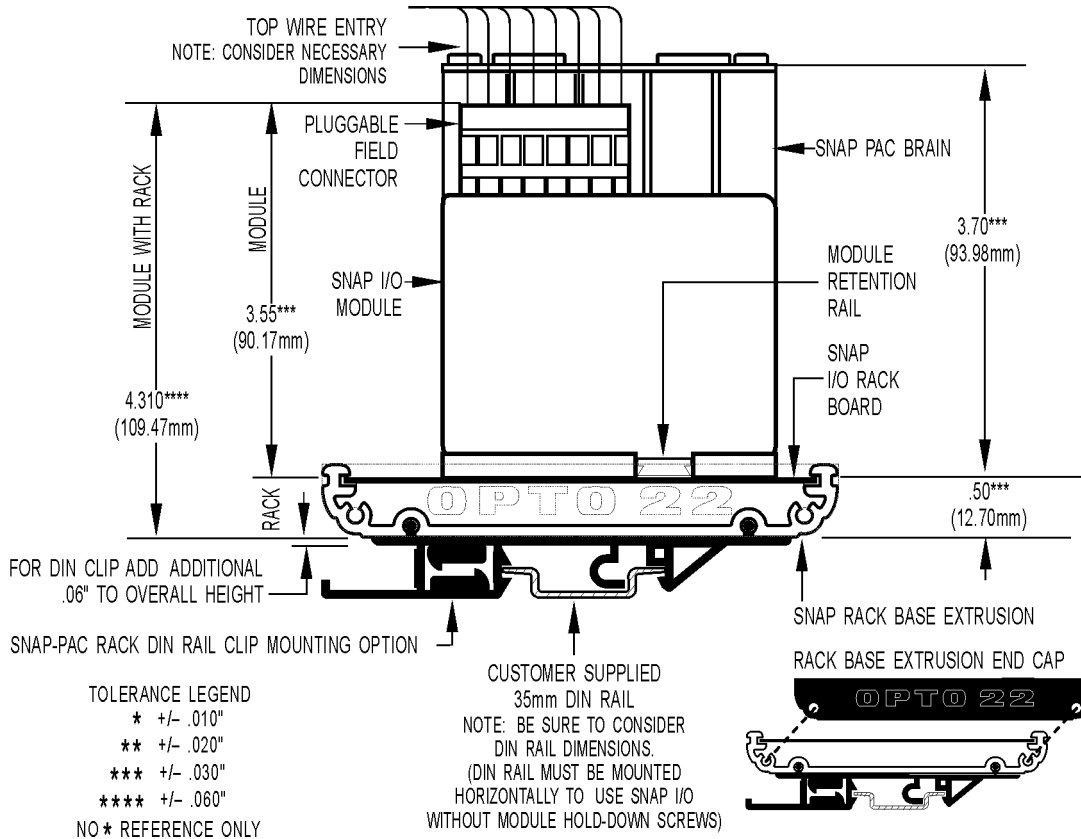

SNAP Analog Input Modules

Dimensional Drawing

Height on Rack: 32-Channel Modules

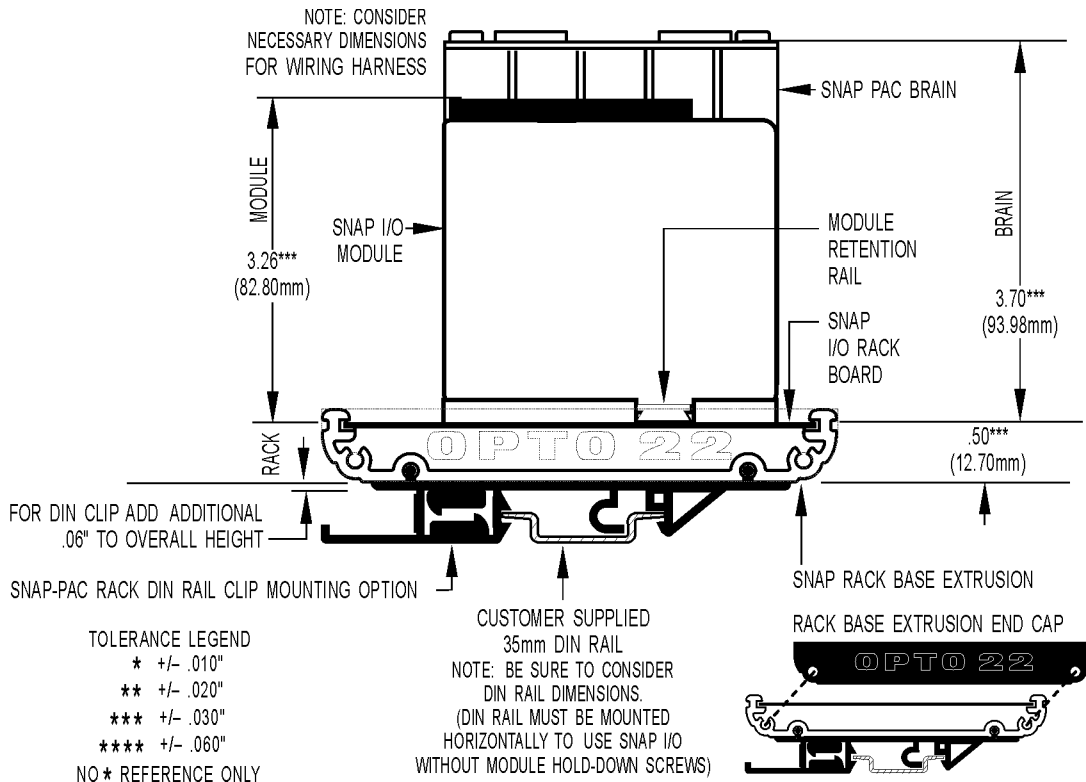

SNAP Analog Input Modules

Dimensional Drawing

Height on Rack: SNAP-AITM-2 Module

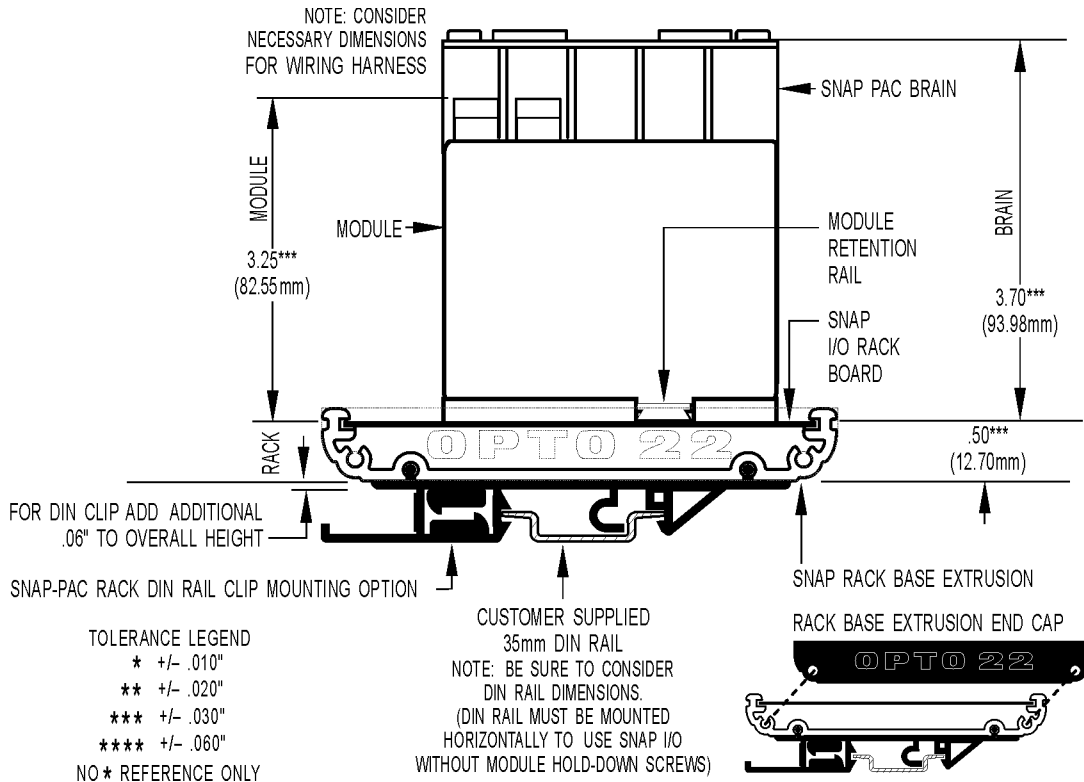

SNAP Analog Input Modules

Dimensional Drawing

Height on Rack: SNAP-AITM-8 and SNAP-AITM-8-FM Modules

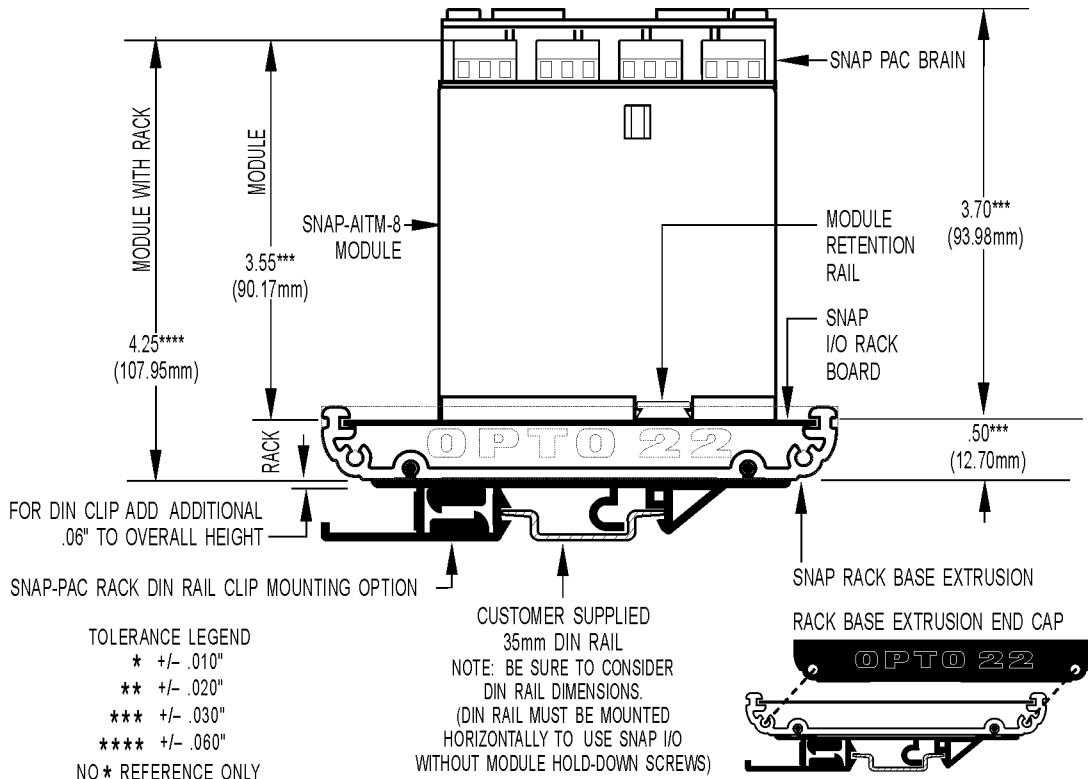

SNAP Analog Input Modules

Dimensional Drawing

Height on Rack: SNAP-AICTD-8, SNAP-AIMA-8, and SNAP-AIV-8

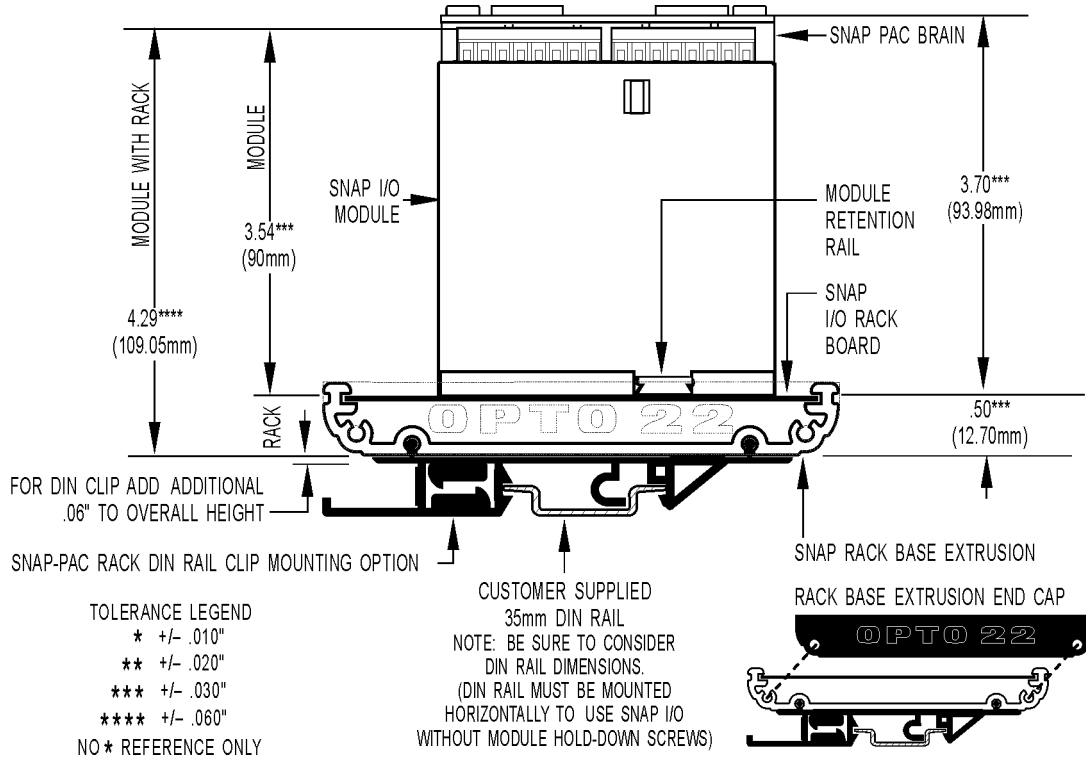

More About Opto 22

Products

Opto 22 develops and manufactures reliable, flexible, easy-to-use hardware and software products for industrial automation, remote monitoring, and data acquisition applications.

SNAP PAC System

Designed to simplify the typically complex process of understanding, selecting, buying, and applying an automation system, the SNAP PAC System consists of four integrated components:

- SNAP PAC controllers
- PAC Project™ Software Suite
- SNAP PAC brains
- SNAP I/O™

SNAP PAC Controllers

Programmable automation controllers (PACs) are multifunctional, multidomain, modular controllers based on open standards and providing an integrated development environment.

Opto 22 has been manufacturing PACs for many years. The latest models include the standalone SNAP PAC S-series and the rack-mounted SNAP PAC R-series. Both handle a wide range of digital, analog, and serial functions and are equally suited to data collection, remote monitoring, process control, and discrete and hybrid manufacturing.

SNAP PACs are based on open Ethernet and Internet Protocol (IP) standards, so you can build or extend a system without the expense and limitations of proprietary networks and protocols.

PAC Project Software Suite

Opto 22's PAC Project Software Suite provides full-featured and cost-effective control programming, HMI (human machine interface) development and runtime, OPC server, and database connectivity software to power your SNAP PAC System.

These fully integrated software applications share a single tagname database, so the data points you configure in PAC Control™ are immediately available for use in PAC Display™, OptoOPCServer™, and OptoDataLink™. Commands are in plain English; variables and I/O point names are fully descriptive.

PAC Project Basic offers control and HMI tools and is free for download on our website, www.opto22.com. PAC Project Professional, available for separate purchase, adds OptoOPCServer, OptoDataLink, options for Ethernet link redundancy or segmented networking, and support for legacy Opto 22 serial *mistic*™ I/O units.

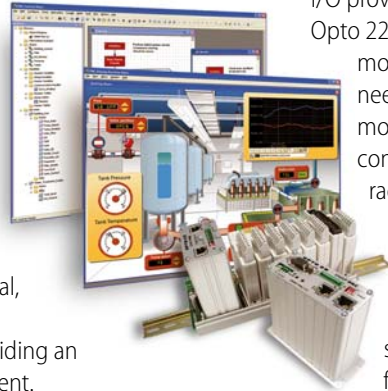

SNAP PAC Brains

While SNAP PAC controllers provide central control and data distribution, SNAP PAC brains provide distributed intelligence for I/O processing and communications. Brains offer analog, digital, and serial functions, including thermocouple linearization; PID loop control; and optional high-speed digital counting (up to 20 kHz), quadrature counting, TPO, and pulse generation and measurement.

SNAP I/O

I/O provides the local connection to sensors and equipment. Opto 22 SNAP I/O offers 1 to 32 points of reliable I/O per module, depending on the type of module and your needs. Analog, digital, serial, and special-purpose modules are all mixed on the same mounting rack and controlled by the same processor (SNAP PAC brain or rack-mounted controller).

Quality

Founded in 1974 and with over 85 million devices sold, Opto 22 has established a worldwide reputation for high-quality products. All are made in the U.S.A. at our manufacturing facility in Temecula, California. Because we do no statistical testing and each part is tested twice before leaving our factory, we can guarantee most solid-state relays and optically isolated I/O modules for life.

Free Product Support

Opto 22's Product Support Group offers free, comprehensive technical support for Opto 22 products. Our staff of support engineers represents decades of training and experience. Product support is available in English and Spanish, by phone or email, Monday through Friday, 7 a.m. to 5 p.m. PST.

Free Customer Training

Hands-on training classes for the SNAP PAC System are offered at our headquarters in Temecula, California. Each student has his or her own learning station; classes are limited to nine students. Registration for the free training class is on a first-come, first-served basis. See our website, www.opto22.com, for more information or email training@opto22.com.

Purchasing Opto 22 Products

Opto 22 products are sold directly and through a worldwide network of distributors, partners, and system integrators. For more information, contact Opto 22 headquarters at 800-321-6786 or 951-695-3000, or visit our website at www.opto22.com.

www.opto22.com