

OPTO 22

DATA SHEET

Form 481-091106

RACKS
CLASSIC
INTEGRAL

page 1/3

Description

The PB16L DC Output Rack provides 16 individual channels of optically-isolated output for controlling or switching small DC loads. Each channel provides up to 4,000 V_{rms} of optical isolation between the field devices and the control logic. All the output circuitry is on the board and all channels are identical. There is no provision on the board for plug-in modules. The PB16L DC Output Rack is smaller than a standard PB16H I/O mounting rack; the result is a 40 percent savings in cabinet space. All outputs are individually fused and indicators are provided for all output channels and power.

Part Number	Description
PB16L	DC Output 5–60VDC 16-channel Integral

The PB16L DC Output rack uses a 50-pin header connector for easy interface to computer parallel I/O ports via 50-conductor ribbon cables. The 50-pin connector also allows direct connection to Mystic, Optomux, and Pamux digital brain boards. The PB16L works with Opto 22 PBSA/B/C power supplies.

Uses for the PB16L DC Output rack include, but are not limited to, controlling the following:

- Low Power DC Relays
- Low Power DC Solenoids
- DC Lamps and Indicators.

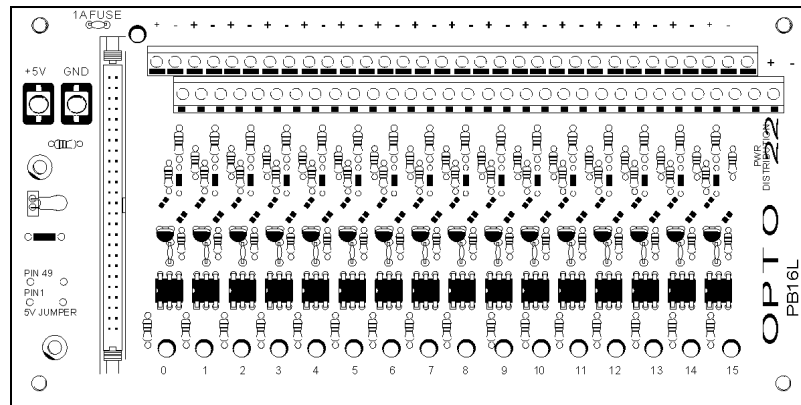

Form 481-091106

Specifications

PB16L Specification

Load Voltage Rating	5–60 VDC
Output Current Rating	0.5 amp @ 45° C 0.2 amp @ 70° C
One Second Surge	1.3 amp
Output Voltage Drop	1.6 VDC maximum
Off-state Leakage @ Maximum Voltage	1 mA maximum
Isolation Input-to-Output Channel-to-Channel	4,000 Vrms 300 Vrms continuous
Turn-on Time:	100 microseconds
Turn-off Time:	100 microseconds
Logic Supply Voltage Range:	4.5–6.0 VDC
Logic Supply Current:	190 mA @ 5 VDC
Operating Ambient Temperature:	- 30° to 70° C

Dimensions

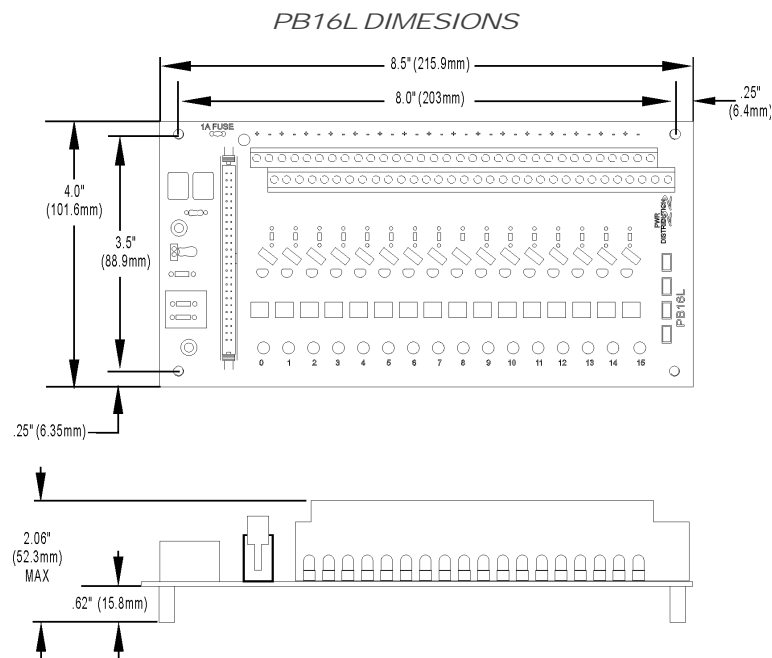

OPTO 22

DATA SHEET

Form 481-091106

RACKS
CLASSIC
INTEGRAL

page 3/3

Connections

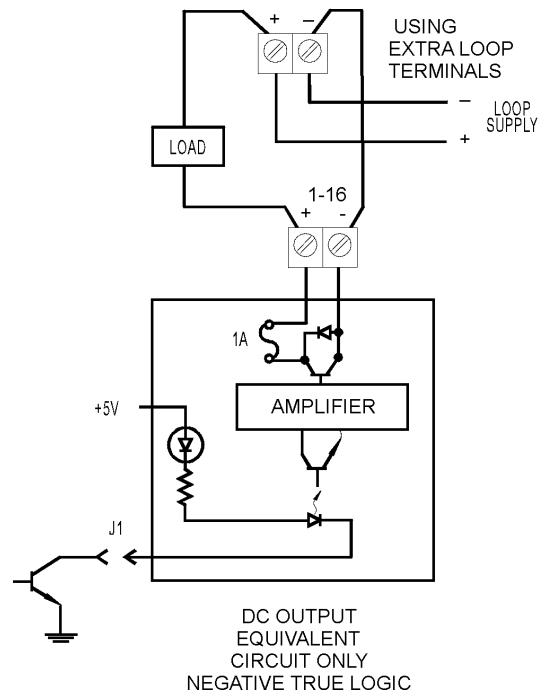
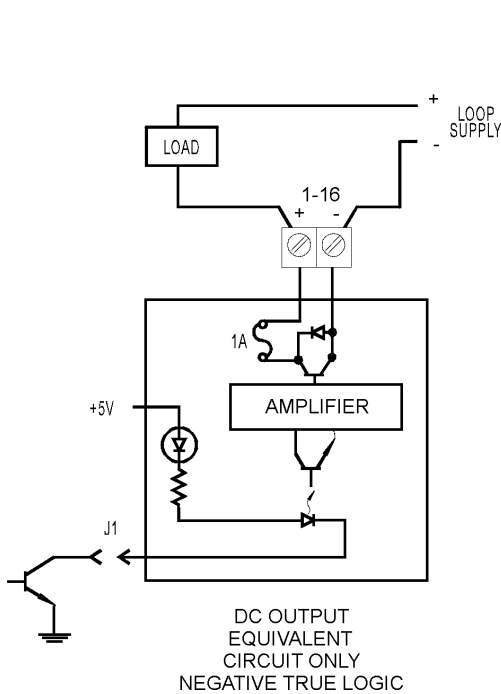
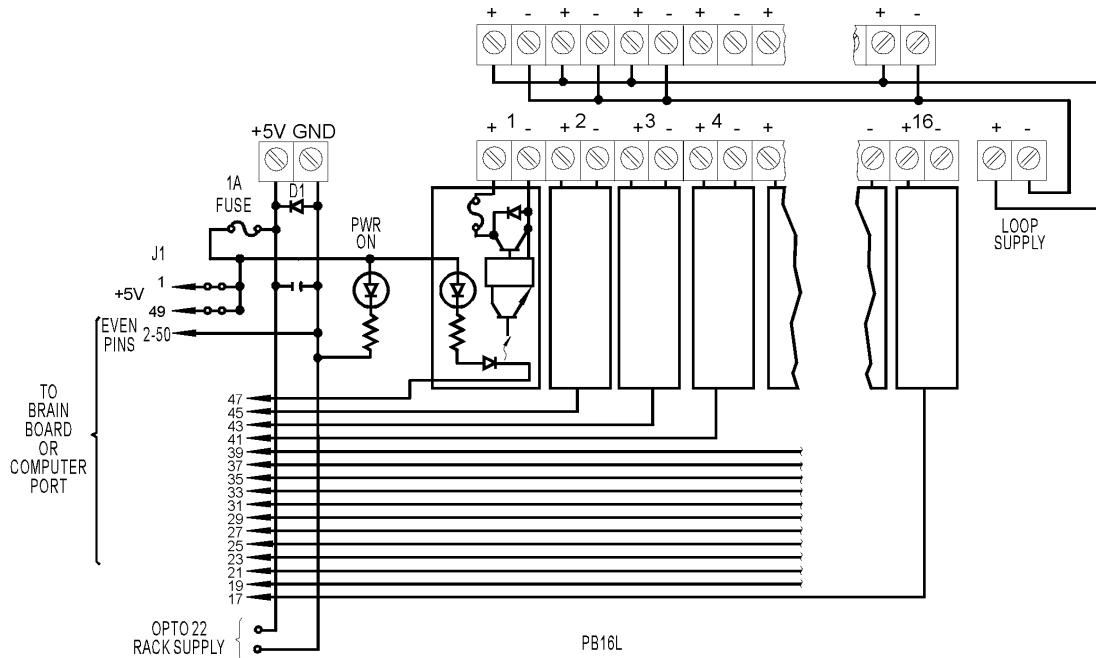

Opto 22 • 43044 Business Park Drive • Temecula, CA 92590-3614 • Phone: (951) 695-3000 • (800) 321-OPTO • Fax: (951) 695-3095 • www.opto22.com

Inside Sales: (800) 321-OPTO • Product Support: (800) TEK-OPTO • (951) 695-3080 • Fax: (951) 695-3017 • E-mail: s@opto22.com

© 1991-2001 Opto 22. All rights reserved. All trademarks, trade names, logos, and service marks referenced herein belong to their respective companies.

More About Opto 22

Products

Opto 22 develops and manufactures reliable, flexible, easy-to-use hardware and software products for industrial automation, remote monitoring, and data acquisition applications.

SNAP PAC System

Designed to simplify the typically complex process of understanding, selecting, buying, and applying an automation system, the SNAP PAC System consists of four integrated components:

- SNAP PAC controllers
- PAC Project™ Software Suite
- SNAP PAC brains
- SNAP I/O™

SNAP PAC Controllers

Programmable automation controllers (PACs) are multifunctional, multidomain, modular controllers based on open standards and providing an integrated development environment.

Opto 22 has been manufacturing PACs for many years. The latest models include the standalone SNAP PAC S-series and the rack-mounted SNAP PAC R-series. Both handle a wide range of digital, analog, and serial functions and are equally suited to data collection, remote monitoring, process control, and discrete and hybrid manufacturing.

SNAP PACs are based on open Ethernet and Internet Protocol (IP) standards, so you can build or extend a system without the expense and limitations of proprietary networks and protocols.

PAC Project Software Suite

Opto 22's PAC Project Software Suite provides full-featured and cost-effective control programming, HMI (human machine interface) development and runtime, OPC server, and database connectivity software to power your SNAP PAC System.

These fully integrated software applications share a single tagname database, so the data points you configure in PAC Control™ are immediately available for use in PAC Display™, OptoOPCServer™, and OptoDataLink™. Commands are in plain English; variables and I/O point names are fully descriptive.

PAC Project Basic offers control and HMI tools and is free for download on our website, www.opto22.com. PAC Project Professional, available for separate purchase, adds OptoOPCServer, OptoDataLink, options for Ethernet link redundancy or segmented networking, and support for legacy Opto 22 serial *mistic*™ I/O units.

SNAP PAC Brains

While SNAP PAC controllers provide central control and data distribution, SNAP PAC brains provide distributed intelligence for I/O processing and communications. Brains offer analog, digital, and serial functions, including thermocouple linearization; PID loop control; and optional high-speed digital counting (up to 20 kHz), quadrature counting, TPO, and pulse generation and measurement.

SNAP I/O

I/O provides the local connection to sensors and equipment. Opto 22 SNAP I/O offers 1 to 32 points of reliable I/O per module, depending on the type of module and your needs. Analog, digital, serial, and special-purpose modules are all mixed on the same mounting rack and controlled by the same processor (SNAP PAC brain or rack-mounted controller).

Quality

Founded in 1974 and with over 85 million devices sold, Opto 22 has established a worldwide reputation for high-quality products. All are made in the U.S.A. at our manufacturing facility in Temecula, California. Because we do no statistical testing and each part is tested twice before leaving our factory, we can guarantee most solid-state relays and optically isolated I/O modules for life.

Free Product Support

Opto 22's Product Support Group offers free, comprehensive technical support for Opto 22 products. Our staff of support engineers represents decades of training and experience. Product support is available in English and Spanish, by phone or email, Monday through Friday, 7 a.m. to 5 p.m. PST.

Free Customer Training

Hands-on training classes for the SNAP PAC System are offered at our headquarters in Temecula, California. Each student has his or her own learning station; classes are limited to nine students. Registration for the free training class is on a first-come, first-served basis. See our website, www.opto22.com, for more information or email training@opto22.com.

Purchasing Opto 22 Products

Opto 22 products are sold directly and through a worldwide network of distributors, partners, and system integrators. For more information, contact Opto 22 headquarters at 800-321-6786 or 951-695-3000, or visit our website at www.opto22.com.

www.opto22.com