

OPTO 22

DATA SHEET

Form 700-030613

**BRAINS
BRICK
DIGITAL**

page 1/12

Description

Part Number	Description
G4D32RS	Remote Digital 32-Channel I/O Unit Mistic Protocol

The G4D32RS is a low-cost, high-I/O-capacity digital unit for the Opto 22 family of PC-based control products. Each I/O unit offers flexible, single-point, on/off control and latching for up to 32 digital I/O points. An easily accessible mounting rack makes field wiring simple to install. Communication connections are attached to a 3-wire terminal block and seamlessly integrate with other RS-485 remote

brain boards, bricks, and modular controller systems. An onboard regulator ensures power protection to the modules and provides a regulated voltage source.

G4D32RS programming is accomplished with OptoControl or Cyrano, Opto 22's intuitive flowchart-based languages, or using a host computer and Opto 22's MisticWare software driver with the software language of your choice.

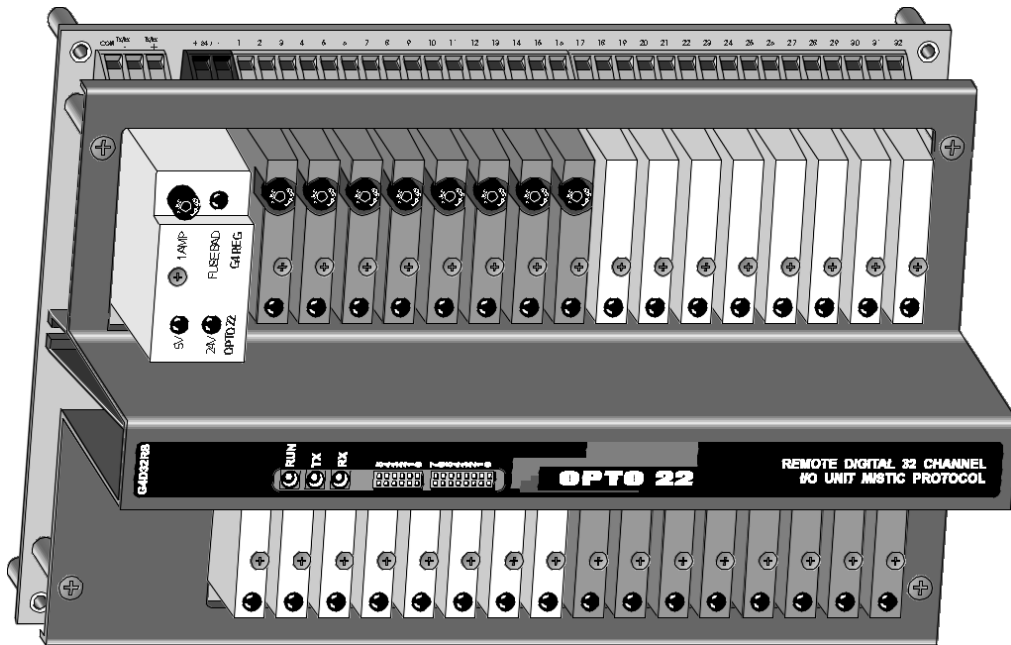

Specifications

CPU CPU clock frequency	8-bit 87C51 processor 22 MHz
Communications Bus speed Cable type Maximum cable length Mode Protocol	300-115.2 Kbd (76.8 K, 150, and 110 baud not supported) 2 twisted pair + ground (interrupts use 1 pair) 3,000 ft. (more with repeaters) Binary or ASCII RS-485, half-duplex
Typical I/O times (includes communication transfer time) Read 16 channels Write 16 channels	1.6 ms 1.8 ms
Latching (minimum pulse width)	100 μ s
Typical operating temperature Storage temperature	-20° to 70° C -40° to 85° C
Humidity	5% to 95% relative humidity
Software	OptoControl, Cyrano, and MysticWare
*Power requirements @ 24 VDC \pm 0.5V with 32 modules installed Terminated (last brick on the bus) Non-terminated (all other bricks)	220 mA 220 mA
Maximum rack field current rating (32 x G4 digital I/O)	48A

Setup and System Commands

Identify unit
Power up clear
Repeat last response
Reset
Set response delay
Clear output

Digital Read/Write, Latch Commands

Read and optionally clear input latches (group command)
Read and optionally clear input latch
Read module status
Set output module state (group command)
Set output

Assembly

The G4D32RS is a high-I/O-capacity digital unit for the Mystic family of PC-based control products. Each unit offers single-point on/off control and latching for up to 32 digital I/O points.

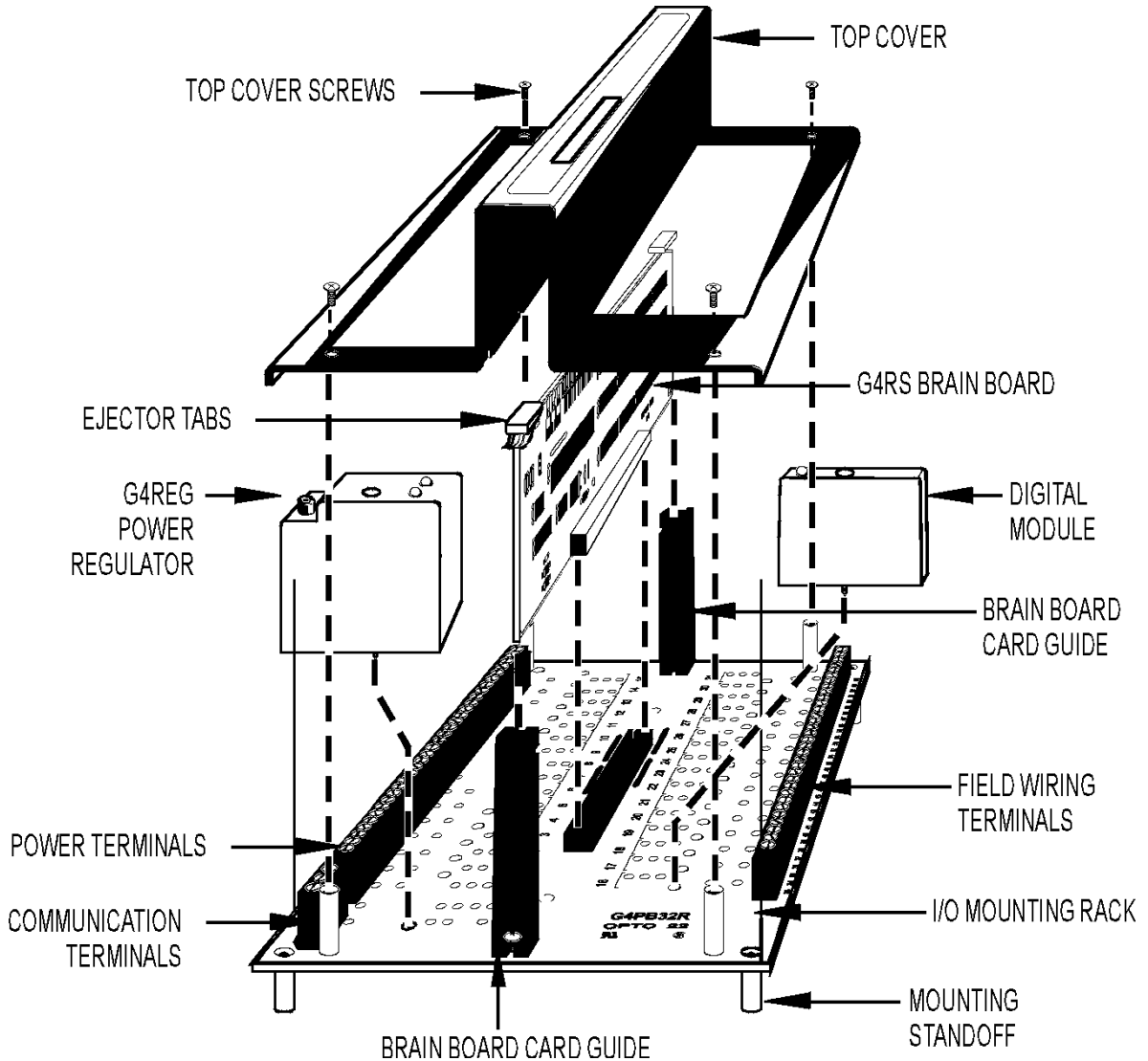
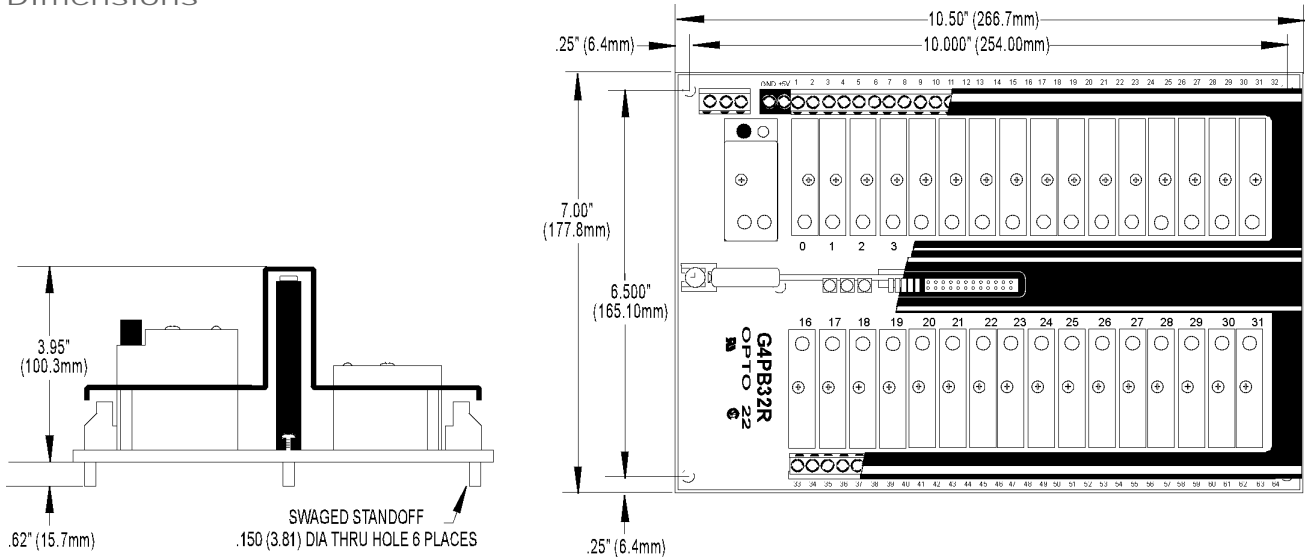

FIGURE 1: EXPLODED VIEW OF THE G4D32RS

Installation Notes

Dimensions



Packing List

When removing the G4D32RS from its packaging, make sure the following components are included:

Component	Use
• Extra jumpers	Can be installed as G4D32RS configuration jumpers
• Screwdriver	Used to install modules
• G4STRAP product insert	Explains how G4STRAP may be used with G4D32RS (Opto 22 form 500) to jumper several points together on the I/O unit

Installation Notes: Setting Configuration Jumpers

Jumpers are included to allow you to configure the G4D32RS based on individual application requirements. Figure 2 shows the G4D32RS jumper groups.

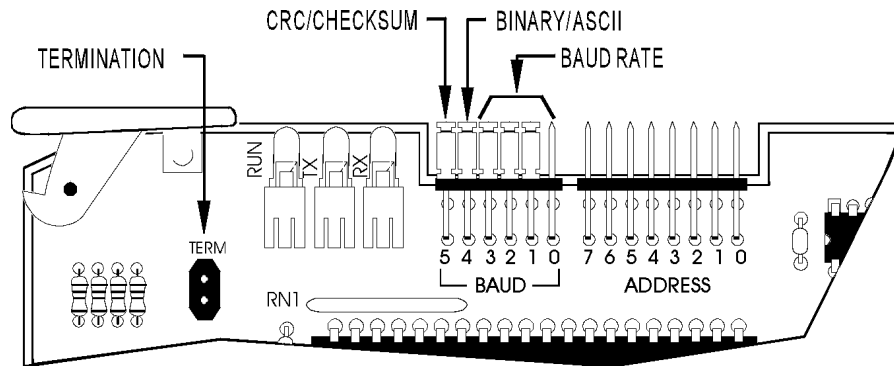

FIGURE 2: CONFIGURATION JUMPERS ON THE G4D32RS

The following sections describe each jumper in detail.

Baud Jumpers (BAUD 0-3)

Use these jumpers to set the baud rate for the G4D32RS. Select the appropriate jumper settings based on the baud rates in Table 1. The I/O unit is shipped with a factory default baud rate of 115.2 KBd.

Table 1: Baud Rate Jumpers

Baud Rate	Jumper Positions			
	0	1	2	3
115.2 KBd	Out	In	In	In
76.8 KBd	Not supported			
57.6 KBd	Out	Out	In	In
38.4 KBd	In	In	Out	In
19.2 KBd	Out	In	Out	In
9600 Bd	In	Out	Out	In
4800 Bd	Out	Out	Out	In
2400 Bd	In	In	In	Out
1200 Bd	Out	In	In	Out
600 Bd	In	Out	In	Out
300 Bd	Out	Out	In	Out

Installation Notes: Setting Configuration Jumpers (cont.)

Termination Jumper (TERM)

Install this jumper if this G4D32RS unit is physically the last I/O unit in the communication link.

Protocol Select Jumper (BAUD 4)

Use this jumper to select whether communication between the host computer/controller and the G4D32RS will be in binary mode (jumper in, the default) or ASCII mode (jumper out).

Data Verification Jumper (BAUD 5)

Use this jumper to select whether the type of data verification method used is Checksum Modulo 256 (jumper out) or CRC16 (jumper in, the default).

CRC16 is typically used when a Mystic controller and Cyrano are used to control the G4D32RS brain boards. If you are using the MysticWARE driver or are sending commands directly from a PC to the brain boards, either data verification method may be used. Make sure the data verification method chosen in the software you are using matches the jumper setting on the brain board.

Address Jumpers (ADDRESS 0-7)

Use these jumpers to select two consecutive eight-bit addresses from 0 to 255 (0 to FF hexadecimal). The 32 channels on the G4D32RS are assigned an even number brick address for channels 0–15, and the next consecutive odd address for channels 16–31. The factory default is 0 (all jumpers out). This setting selects addresses 0 and 1. The most significant bit is 7, and the least significant bit is 0. To set the jumpers based on a predetermined address, refer to Figure 3 on the following page.

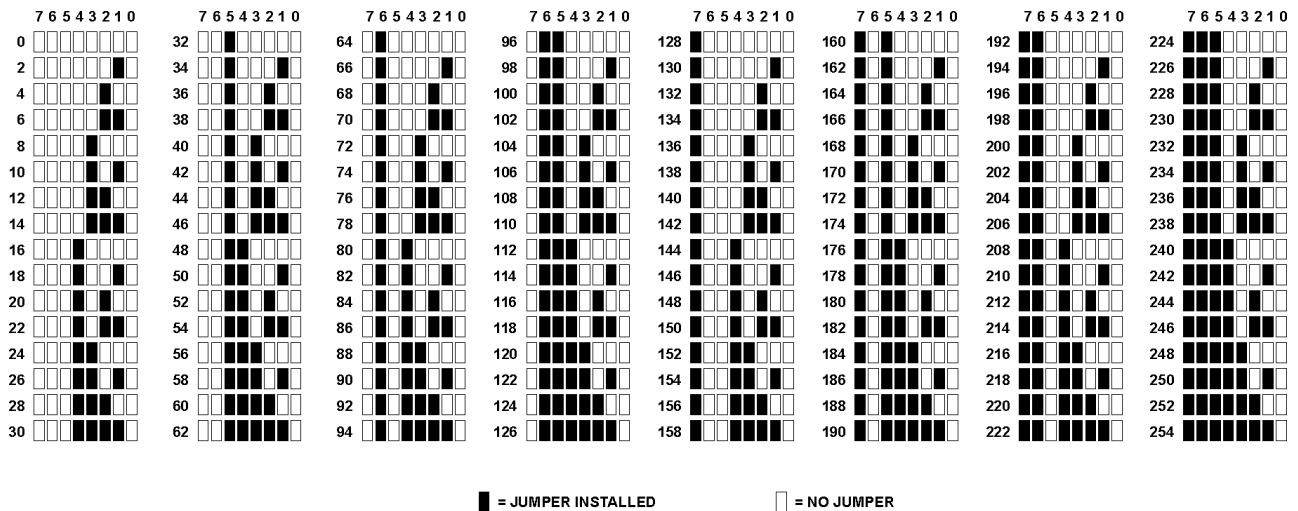

FIGURE 3: G4D32RS ADDRESS JUMPER CONFIGURATIONS

Installation Notes: Mounting the G4D32RS

1. Remove the four top cover screws and lift off the top cover.
2. Affix the G4D32RS to an enclosure or panel, using the mounting standoffs shown in Figure 4.

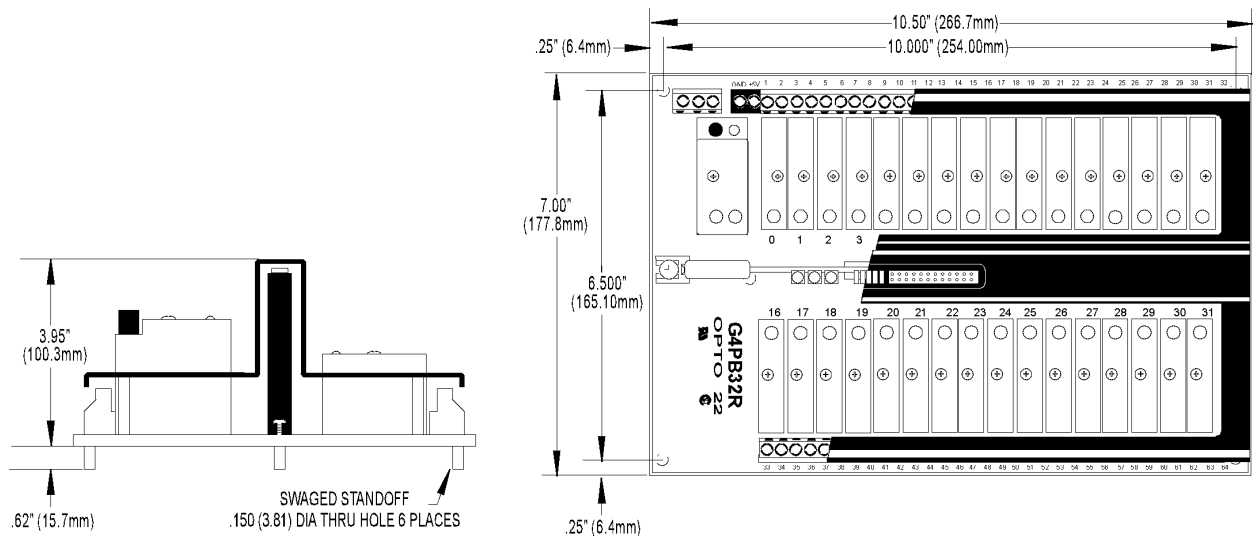

FIGURE 4: G4D32RS DIMENSIONS AND MOUNTING INFORMATION

3. Connect power, field, and communication wiring. Refer to the appropriate sections in this document for instructions.
4. Replace the top cover and secure to the mounting rack with the top cover screws.

Connecting Power to the G4D32RS

The G4D32RS requires 250 mA @ 24 ±0.5 VDC.

Follow the instructions below to wire power to the I/O unit.

1. Turn off the power supply switch.
2. Make sure all power supply terminal block connections are completely open by turning the power terminal screw counterclockwise.
3. Prepare each power supply wire, being careful not to strip back the insulation too far.
4. Refer to Figure 5 and insert the power supply's "+" wire into the "+24V" terminal and the power supply's "-" wire into the "-24V" terminal. Tighten down each wire by turning the power terminal screw clockwise. Make sure the terminal block is clamping the wire and not the insulation.

Installation Notes: Connecting Power to the G4D32RS (cont.)

G4REG

The onboard regulator (Opto 22 P/N G4REG) converts the 24 VDC to the 5 VDC required by the I/O unit's brain board and modules. Three LED indicators are on the regulator. A lit "24V" LED indicates the G4REG is receiving adequate 24 VDC power; an unlit LED indicates it is not receiving adequate power. A lit "5V" LED indicates the G4REG is properly converting the 24 VDC to 5 VDC; an unlit LED indicates power is not being converted properly. The "FUSE BAD" LED lights when the 1 A fuse (Opto 22 P/N FUSE01G4 or Wickman P/N 19373-1A) in the regulator needs to be replaced.

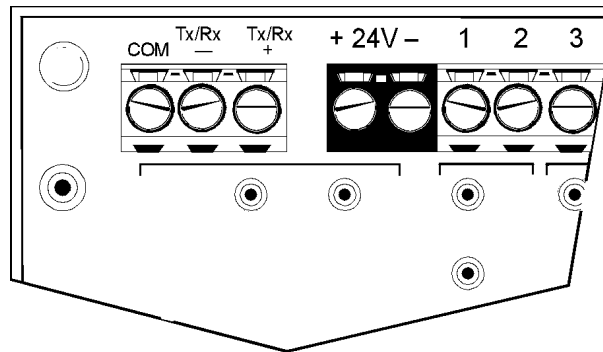

FIGURE 5: CONNECTING POWER TO THE G4D32RS

Installation Notes: Connecting Field Wiring

Caution: TURN OFF POWER to the G4D32RS before connecting or removing field wiring.

Figure 6 shows the location of the field wiring terminals on the G4D32RS and the layout of the terminal points as they correspond to each channel. Field wiring terminals accept up to 10 AWG wire.

Each channel has a positive (+), odd numbered terminal and a negative (-), even numbered terminal for each channel. Connect the positive wire from your field device to the channel's positive terminal, and then connect the negative wire to the negative terminal. Table 2 on page 7 lists the channel numbers, their respective field terminals, and pinouts to the header connector.

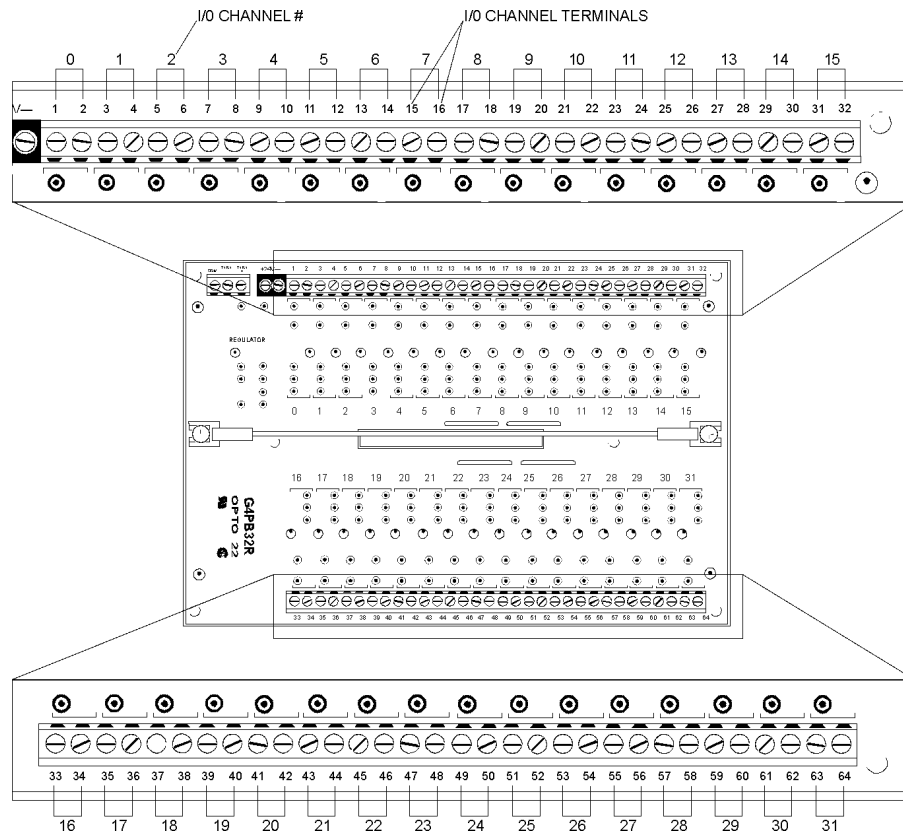

FIGURE 6: LOCATION OF TERMINALS ON THE G4D32RS

Bussing Points Together

Several field terminals may be bussed together by using Opto 22 P/N G4STRAP. One G4STRAP may jumper up to 16 positions. It may also be trimmed to jumper fewer points together. See Figure 7 for an example of how the G4STRAP is used on the G4D32RS.

Installation Notes: Connecting Field Wiring (cont.)

Table 2: Channel Positions and Field Terminals

Module Position	Control (Header Connector)	Field (Terminal Strip) + and -
0	40	1 and 2
1	39	3 and 4
2	42	5 and 6
3	41	7 and 8
4	44	9 and 10
5	43	11 and 12
6	46	13 and 14
7	45	15 and 16
8	48	17 and 18
9	47	19 and 20
10	50	21 and 22
11	49	23 and 24
12	52	25 and 26
13	51	27 and 28
14	54	29 and 30
15	53	31 and 32
16	56	33 and 34
17	55	35 and 36
18	58	37 and 38
19	57	39 and 40
20	60	41 and 42
21	59	43 and 44
22	62	45 and 46
23	61	47 and 48
24	64	49 and 50
25	63	51 and 52
26	66	53 and 54
27	65	55 and 56
28	68	57 and 58
29	67	59 and 60
30	70	61 and 62
31	69	63 and 64

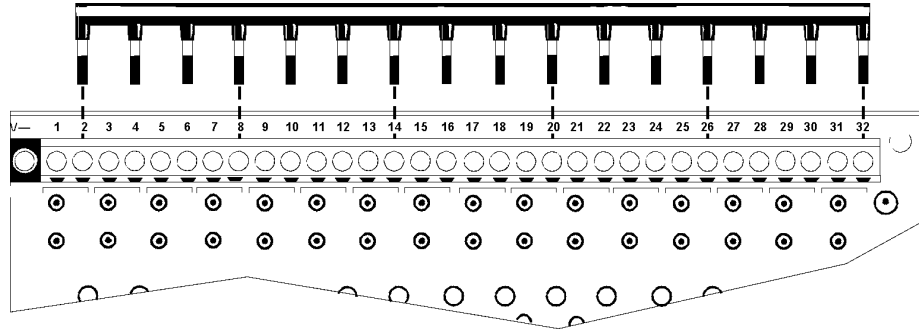

FIGURE 7: G4STRAP USED ON THE G4D32RS

Connecting Communication Wiring

Caution: TURN OFF POWER to the G4D32RS before connecting or removing communication wiring.

There are three terminals for communication wiring on the G4D32RS I/O unit. The unit communicates using two-wire, RS-485 protocol. Refer to Figure 8 for wiring connections.

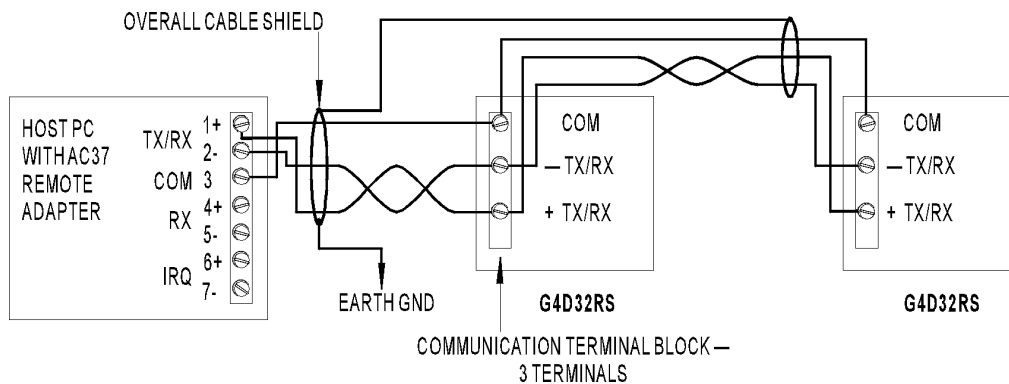

FIGURE 8: TWO-WIRE COMMUNICATION WIRING TO THE G4D32RS I/O UNIT

Programming

The G4D32RS may be controlled directly from a PC or with a Mystic controller and the Cyrano programming language. Refer to the *Analog and Digital Commands Manual* (Opto 22 form 270) or the *MisticWARE Driver Reference Manual* (Opto 22 form 522) for programming information if you are using a PC to control the I/O unit. Refer to the *Cyrano User's Guide* (Opto 22 form 702) for programming information if you are using a Mystic controller to control the I/O unit.

When configuring the G4D32RS in software, remember it occupies two consecutive eight-bit addresses. An even I/O address is assigned to channels 0–15, and the next consecutive address is assigned to channels 16–31. Refer to "Address Jumpers" on page 3 for more information about addressing.

Installation Notes: LED Indicators

Three LEDs are located on the G4D32RS brain board. These LEDs perform the functions described in Table 3.

Table 3: LED Functions

LED	Indication
RUN (Brain board status)	This indicator shows brain board status. When the brain board is functioning normally, the light stays on. When the brain board is powered down, the light goes off. If the light begins to blink, it could indicate a brain board malfunction or low power supply voltage.
TX (Transmit)	This indicator illuminates (and appears to flash on and off) whenever the serial port is transmitting data. If the LED fails to illuminate, it could indicate the port is idle. Check Figure 8 for the appropriate wiring configuration.
RX (Receive)	This indicator illuminates whenever the serial port is receiving data. If the LED fails to illuminate, it could indicate that the port is idle. An LED that is constantly on may indicate receive communication wires are connected to the opposite polarity. Check Figure 8 for the appropriate wiring configuration.

Products

Opto 22 produces a broad array of reliable, flexible hardware and software products for industrial automation, remote monitoring, enterprise data acquisition, and machine-to-machine (M2M) applications.

SNAP Ethernet Systems

Based on the Internet Protocol (IP), SNAP Ethernet systems offer flexibility in their network connectivity and in the software applications they work with. The physical network may be a wired Ethernet network, a cellular wireless network, or a modem. A wide variety of software applications can exchange data with SNAP Ethernet systems, including:

- Opto 22's own ioProject™ suite of control and HMI software
- Manufacturing resource planning (MRP), enterprise management, and other enterprise systems
- Human-machine interfaces (HMIs)
- Databases
- Email systems
- OPC client software
- Custom applications
- Modbus/TCP software and hardware.



SNAP Ethernet system hardware consists of controllers and I/O units. Controllers provide central control and data distribution. I/O units provide local connection to sensors and equipment.

SNAP OEM Systems

Opto 22 SNAP OEM I/O systems are highly configurable, programmable processors intended for OEMs, IT professionals, and others who need to use custom software with Opto 22 SNAP I/O modules.

Linux® applications running on these systems can read and write to analog, simple digital, and serial I/O points on SNAP I/O modules using easily implemented file-based operations. Applications can be developed using several common development tools and environments, including C or C++, Java, and shell scripts.



M2M Systems

Machine-to-machine (M2M) systems connect your business computer systems to the machines, devices, and environments you want to monitor, control, or collect data from. M2M systems often use wireless cellular communications to link remote facilities to central systems over the Internet, or to provide monitoring and control capability via a cellular phone.

Opto 22's Nvio™ systems include everything you need for M2M—interface and communications hardware, data service plan, and Web portal—in one easy-to-use package. Visit nvio.opto22.com for more information.

Opto 22 Software

Opto 22's ioProject and FactoryFloor® software suites provide full-featured and cost-effective control, HMI, and OPC software to power your Opto 22 hardware. These software applications help you develop control automation solutions, build easy-to-use operator interfaces, and expand your manufacturing systems' connectivity.



Quality

In delivering hardware and software solutions for worldwide device management and control, Opto 22 retains the highest commitment to quality. We do no statistical testing; each product is made in the U.S.A. and is tested twice before leaving our 160,000 square-foot manufacturing facility in Temecula, California. That's why we can guarantee solid-state relays and optically-isolated I/O modules *for life*.

Product Support

Opto 22's Product Support Group offers comprehensive technical support for Opto 22 products. The staff of support engineers represents years of training and experience, and can assist with a variety of project implementation questions. Product support is available in English and Spanish from Monday through Friday, 7 a.m. to 5 p.m. PST.

Opto 22 Web Sites

- www.opto22.com
- nvio.opto22.com
- www.internetio.com (live Internet I/O demo)

Other Resources

- OptoInfo CDs
- Custom integration and development
- Hands-on customer training classes.



About Opto 22

Opto 22 manufactures and develops hardware and software products for industrial automation, remote monitoring, enterprise data acquisition, and machine-to-machine (M2M) applications. Using standard, commercially available Internet, networking, and computer technologies, Opto 22's input/output and control systems allow customers to monitor, control, and acquire data from all of the mechanical, electrical, and electronic assets that are key to their business operations. Opto 22's products and services support automation end users, OEMs, and information technology and operations personnel.

Founded in 1974 and with over 85 million Opto 22-connected devices deployed worldwide, the company has an established reputation for quality and reliability.