

SNAP I/O Control System

Product Guide

page 1/9

Form 788-001113

Opto 22's SNAP Control System is a versatile combination of hardware and software to support a wide variety of business applications. The system consists of high-density digital, analog, and special-purpose I/O modules, compact industrial controllers, high-performance processor brains, and a series of mounting racks. Coupled with Opto 22's powerful FactoryFloor industrial automation software, SNAP offers unparalleled flexibility and power for your control, monitoring, and data acquisition needs.

SNAP I/O MODULES

SNAP analog and digital input and output modules provide compact, high-density I/O, with top-mounted connectors for easy field wiring.

SNAP digital modules switch or sense either AC or DC signals. Each module includes four channels and provides 4,000 volts of optical isolation from the field side to the logic side.

SNAP analog modules provide two or four channels. They are factory calibrated and software configurable, handling a wide variety of signal levels.

SNAP special-purpose modules provide specific functionality. Using serial modules, for example, you can communicate with serial devices such as chart recorders and barcode readers. Data-logging modules provide data storage capacity, so that data from other modules on the same rack can be stored for later retrieval. PID modules monitor input signals and adjust output signals to control a proportional integral derivative (PID) loop, performing all PID calculations in the module.

SNAP I/O Modules, Rack, and SNAP Ethernet Brain

SNAP BRAINS

SNAP brains are high-performance, intelligent processors designed to meet your distributed control needs. Capable of controlling up to 64 channels of mixed analog and digital I/O, or digital only, SNAP brains communicate in several ways. SNAP Ethernet brains communicate via TCP/IP over Ethernet at speeds up to 100 megabits per second. Within the TCP/IP packet are several protocols, including the IEEE 1394 Firewire packet and Modbus/TCP. SNAP Wireless LAN brains also communicate via TCP/IP but use wireless LAN for physical connections. The serial versions of the SNAP brain use Optomux, Mystic, or Modbus protocols. A Profibus-DP brain and ARCNET brains are also available. All SNAP-supported protocols developed by Opto 22 are freely distributed and fully documented.

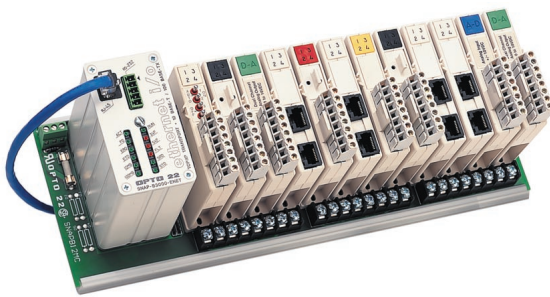

SNAP INDUSTRIAL CONTROLLERS

Powerful SNAP controllers provide real-time control and communication to I/O systems, serial devices, motion controllers, and networks. SNAP controllers range from the cost-effective, small-footprint SNAP-LCSX, ideal for distributed automation, to the powerful SNAP-LCM4. Expansion options for the SNAP-LCM4 controller include adapter cards for twisted-pair and fiber optic ARCNET, as well as 100-Mbps Ethernet with TCP/IP.

SNAP RACKS

SNAP racks come in four sizes to accommodate a maximum of 4, 8, 12, or 16 modules.

Versatile SNAP B-series racks accept both digital and analog modules on the same rack, and use SNAP brains to communicate with either an Opto 22 controller or a host computer.

SNAP D-series racks are designed for digital applications only. They can be populated with digital SNAP I/O modules and connected directly to a PC through an I/O adapter card, or be used with SNAP Ethernet, Profibus-DP, or other brains.

349 FACTORYFLOOR SOFTWARE

Closely integrated with the SNAP I/O system is Opto 22's FactoryFloor®, the full-featured software suite designed to help you solve control automation problems, build easy-to-use operator interfaces, and expand your manufacturing systems' connectivity. FactoryFloor includes OptoControl, OptoDisplay, OptoServer, and OptoConnect.

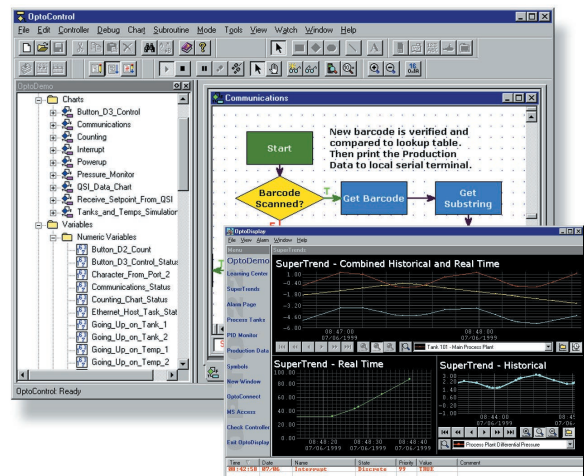

CONTROLLERS

SNAP-LCM4*	SNAP modular M4 controller
SNAP-LCSX*	SNAP controller with 2 COM ports
SNAP-LCSX-PLUS*	SNAP controller with 4 COM ports
M4SENET-100*	Ethernet card for M4 series controllers

BRAINS

SNAP-B3000-ENET*	Analog/digital/serial Ethernet brain
SNAP-ENET-D64	Digital-only Ethernet brain
SNAP-ENET-RTC	Analog/digital/serial Ethernet brain with real-time clock
SNAP-WLAN-FH-ADS	Analog/digital/serial wireless LAN brain
B3000*	Analog/digital brain, Mystic/Optomux protocol, serial
B3000-HA	Analog/digital brain, Mystic/Optomux protocol, dual ARCNET
SNAP-B3000-MODBUS	Analog/digital Modbus slave, ASCII or RTU protocol
SNAP-BRS	Remote digital read/write brain, Mystic protocol, serial
SNAP-BRS-HA	Remote digital read/write brain, Mystic protocol, dual ARCNET
SNAP-B4	High-speed digital brain, Pamux protocol
SNAP-B6	High-speed analog/digital brain, Pamux protocol
SNAP-PDPRS64	Profibus-DP digital slave brain

* Factory Mutual (FM) approved

Form 788-001113

B-SERIES RACKS

SNAP-B4M*	4-module rack
SNAP-B8M*	8-module rack
SNAP-B8MC/MC-P	8-module rack with extra terminal block for field wiring, (MC-P is pluggable)
SNAP-B12M*	12-module rack
SNAP-B12MC/MC-P	12-module rack with extra terminal block for field wiring, (MC-P is pluggable)
SNAP-B16M*	16-module rack
SNAP-B16MC/MC-P	16-module rack with extra terminal block for field wiring, (MC-P is pluggable)

D-SERIES RACKS

SNAP-D64RS	16-module digital-only rack for Profibus or Ethernet SNAP brains
SNAP-D4M	4-module digital-only rack
SNAP-D4MC/MC-P	4-module digital-only rack with extra terminal block for field wiring, (MC-P is pluggable)
SNAP-D6M	6-module digital-only rack
SNAP-D6MC/MC-P	6-module digital-only rack with extra terminal block for field wiring, (MC-P is pluggable)
SNAP-D8M	8-module digital-only rack
SNAP-D8MC/MC-P	8-module digital-only rack with extra terminal block for field wiring, (MC-P is pluggable)
SNAP-D12M	12-module digital-only rack
SNAP-D12MC/MC-P	12-module digital-only rack with extra terminal block for field wiring, (MC-P is pluggable)

* Factory Mutual (FM) approved

DIGITAL MODULES

AC INPUT

SNAP-IAC5	4-channel, 90–140 VAC input, 5 VDC logic
SNAP-IAC5A	4-channel, 180–280 VAC input, 5 VDC logic
SNAP-IAC5MA	4-channel, isolated, 90–140 VAC input, 5 VDC logic, manual/auto switch
SNAP-IAC5FM*	4-channel, 90–140 VAC/VDC input, 5 VDC logic
SNAP-IAC5AFM*	4-channel, 180–280 VAC input, 5 VDC logic

DC INPUT

SNAP-IDC5	4-channel, 10–32 VDC input, 5 VDC logic
SNAP-IDC5FM*	4-channel, 10–32 VDC input, 5 VDC logic
SNAP-IDC5D	4-channel, 2.5–28 VDC input, 5 VDC logic
SNAP-IDC5DFM*	4-channel, 2.5–28 VDC input, 5 VDC logic
SNAP-IDC5-FAST	4-channel, high-speed, 2.5–16 VDC input, 5 VDC logic
SNAP-IDC5-FAST-A	4-channel, high-speed, 18–32 VDC input, 5 VDC logic
SNAP-IDC5MA	4-channel, isolated, high-speed, 10–32 VAC input, 5 VDC logic, manual/auto switch
SNAP-IDC5Q	SNAP two-axis quadrature position input
SNAP-IAC5	4-channel, 90–140 VAC input, 5 VDC logic
SNAP-IAC5A	4-channel, 180–280 VAC input, 5 VDC logic

* Factory Mutual (FM) approved

Form 788-001113

DIGITAL MODULES (CONT.)

AC OUTPUT

SNAP-0AC5	4-channel, 12–280 VAC input, 5 VDC logic
SNAP-0AC5FM*	4-channel, 12–280 VAC input, 5 VDC logic
SNAP-0AC5MA	4-channel, isolated, 12–280 VAC output, 5 VDC logic, manual/auto switch
SNAP-0AC5-i	4-channel, isolated, 12–280 VAC output, 5 VDC logic
SNAP-0AC5-iFM*	4-channel, isolated, 12–280 VAC output, 5 VDC logic

DC OUTPUT

SNAP-0DC5SRC	4-channel, 5–60 VDC logic, source
SNAP-0DC5SRCFM*	4-channel, 5–60 VDC logic, source
SNAP-0DC5SNK	4-channel, 5–60 VDC logic, sink
SNAP-0DC5SNKFM*	4-channel, 5–60 VDC logic, sink
SNAP-0DC5ASNK	4-channel, 5–200 VDC output, 5 VDC logic, sink
SNAP-0DC5R	4-channel, dry contact output, normally open
SNAP-0DC5RFM*	4-channel, dry contact output, normally open
SNAP-0DC5R5	4-channel, dry contact output, normally closed
SNAP-0DC5R5FM*	4-channel, dry contact output, normally closed
SNAP-0DC5MA	4-channel, isolated, 5–60 VDC output, 5 VDC logic, manual/auto switch
SNAP-0DC5-i	4-channel, isolated, 5–60 VDC output, 5 VDC logic
SNAP-0DC5-iFM*	4-channel, isolated, 5–60 VDC output, 5 VDC logic
SNAP-0DC5A-i	4-channel, isolated, 5–200 VDC output, 5 VDC logic
SNAP-0DC5A-iFM*	4-channel, isolated, 5–200 VDC output, 5 VDC logic

* Factory Mutual (FM) approved

ANALOG MODULES

INPUT

SNAP-AICTD-4	4-channel, analog temperature input, ICTD
SNAP-AIMA-4	4-channel, analog current input, -20mA to +20mA
SNAP-AIR40K-4	4-channel, analog thermistor input
SNAP-AIMV-4	4-channel, -150 mV to +150 mV input or -75 mV to +75 mV
SNAP-AIMV2-4	4-channel, -50 mV to +50 mV input or -25 mV to +25 mV
SNAP-AIV-4	4-channel, analog voltage input, -10 VDC to +10 VDC
SNAP-AIARMS	2-channel, AC/DC input, 0–10 amp RMS
SNAP-AIVRMS	2-channel, AC/DC input, 0–250 V RMS
SNAP-AICTD	2-channel, analog temperature input, ICTD
SNAP-AIMA	2-channel, analog current input, -20mA to +20mA
SNAP-AIMA-i	2-channel, analog current input, isolated, -20mA to +20mA
SNAP-AIRATE	2-channel, analog rate input, 0 to 25,000 Hz
SNAP-AITM	2-channel, analog, type E, J, K thermocouple or -150 mV to +150mV input or -75 mV to +75mV input
SNAP-AITM-i	2-channel, analog, isolated, type E, J, K thermocouple or -150 mV to +150mV input or -75 mV to +75mV input
SNAP-AITM-2	2-channel, analog, type B, C, D, G, N, T, R, or S thermocouple or -50 mV to +50mV DC input or -25 mV to +25mV DC input
SNAP-AITM2-i	2-channel, analog, isolated, type B, C, D, G, N, T, R, or S thermocouple or -50 mV to +50mV DC input or -25 mV to +25mV DC input
SNAP-AIRTD	2-channel, 100-ohm, platinum RTD input
SNAP-AIV	2-channel, analog voltage input, isolated, -10 VDC to +10 VDC
SNAP-AIV-i	2-channel, analog voltage input, isolated, -10 VDC to +10 VDC

Note: All 4-channel analog modules are for use with Ethernet and Wireless LAN brains only.

Form 788-001113

ANALOG MODULES (CONT.)

OUTPUT

SNAP-A0A-23	2-channel, analog output current, 4–20mA
SNAP-A0V-25	2-channel, analog output voltage, 0 to +10 VDC
SNAP-A0V-27	2-channel, analog output voltage, -10 to +10 VDC
SNAP-A0A-28	2-channel, analog output current loop, 0–20mA
SNAP-A0D-29	2-channel, analog time-proportional digital output, 5–60 VDC
SNAP-A0A-3	Single-channel, analog output current, 4–20mA
SNAP-A0V-5	Single-channel, analog output voltage, 0 to +10 VDC
SNAP-A0V-7	Single-channel, analog output voltage, -10 to +10 VDC

SPECIAL-PURPOSE MODULES

SNAP-SCM-232	2-channel, RS-232 serial communication module
SNAP-SCM-485	2-channel, RS-485 (two-wire) serial communication module
SNAP-PID-V	2-channel 0–5 VDC or 0–10 VDC reference input, 4–20 mA or 0–10 VDC PID output
SNAP-DATA	Data-logging module with battery-backed real-time clock

Form 788-001113

POWER SUPPLIES

- SNAP-PS5*** Supplies 5 volts at 4 amps; 120 VAC input
- SNAP-PS5-24DC*** Supplies 5 volts at 4 amps; 24 VDC input
- SNAP-PS24*** Supplies 3/4 amp at 24 volts to power current loops
- SNAP-PSDIN** DIN-rail adapter for power supply

ACCESSORIES/REPLACEMENT PARTS

(FOR SNAP RACKS AND MODULES)

- SNAP-CDBBDIN** Classic digital brain DIN-rail adapter
- SNAP E-Z REMOVAL TOOL** (no part number) shipped with SNAP modules
- SNAP-FIELDCONB** Module field connector
- SNAP-FUSE1AB** 1-amp fuse, 25-pack
- SNAP-FUSE4AB** 4-amp fuse, 25-pack
- SNAP-LABEL4B** 4-module label holder with labels, 25-pack
- SNAP-LABEL6B** 6-module label holder with labels, 25-pack
- SNAP-MODFUSEH** Digital output module fuse holder, 10-pack
- SNAP-MODLATCHB** Module release latch, 10-pack
- SNAP-RACKDIN** SNAP rack DIN-rail adapter clip
- SNAP-RACKDINB** SNAP rack DIN-rail adapter clip, 25-pack
- SNAP-RETN4** 4-module retention rail (OEM)
- SNAP-RETN4B** 4-module retention rail, 25-pack
- SNAP-RETN6** 6-module retention rail (OEM)
- SNAP-RETN6B** 6-module retention rail, 25-pack
- SNAP-STRAP*** Jumper strap for SNAP module field wiring connector
- SNAP-WIRESTRAP*** Jumper for SNAP-STRAPS

* Factory Mutual (FM) approved

OPTO 22 DATA SHEET

SOLID-STATE RELAYS

Form 859-000511

Overview

In 1974, Opto 22 introduced the first liquid epoxy-filled line of power solid-state relays (SSR). This innovation in SSR design greatly improved the reliability and reduced the cost of manufacturing. At that time, we also incorporated into our manufacturing process 100% testing of every relay produced under full load conditions. By 1978, Opto 22 had gained such

a reputation for reliability that we were recognized as the world's leading manufacturer of solid-state relays. Through continuous manufacturing improvements and the same 100% testing policy established 22 years ago, Opto 22 is still recognized today for the very high quality and reliability of its complete line of solid-state relays.

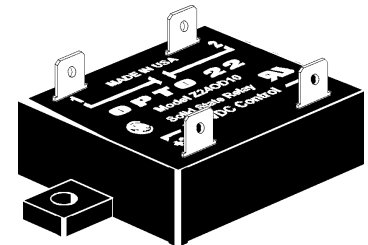
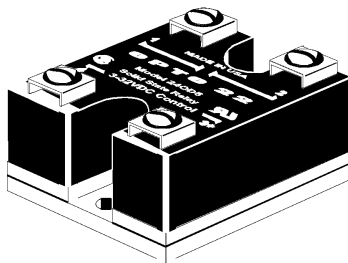

Index

Power Series

Z Series

Page	Description
1	Introduction
2	All Models: General Specifications
3	120/240 Volt AC Power Series: General Specifications
4	120/240 Volt AC Power Series: Surge Current Data, Thermal Data, and Dimensions
5	480/575 Volt AC Power Series: General Specifications
6	120/240 Volt AC Power Series Plastic Package (Z Series): General Specifications
7	AC Power Printed Circuit Series: General Specifications
9	DC Switching Series: General Specifications
APPLICATION TIPS	
10	Heat Sink Calculation, Duty Cycle Calculation
11	Transformer Loads, Solenoid Loads, and Lamp Loads
12	Solid-State Relays in Series, Lamp Loads, Heater Loads
13	Motor Loads

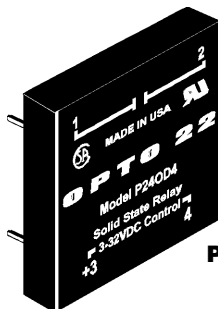

P Series

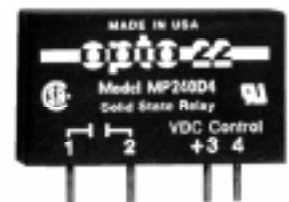

MP Series

Form 859-000511

Specifications

All Models

- 4,000 V optical isolation input to output
- Zero voltage turn-on
- Turn-on time: ½ cycle maximum
- Turn-off time: ½ cycle maximum
- Operating frequency: 25 to 65 Hz (operates at 400 Hz with six times off-state leakage)
- Coupling capacitance input to output: 8 pF maximum
- DV/DT Off-state: 200 volts per microsecond
- DV/DT commutating: snubbed for rated current at 0.5 power factor
- UL recognized
- CSA certified
- CE component

Safety Cover

Power Series

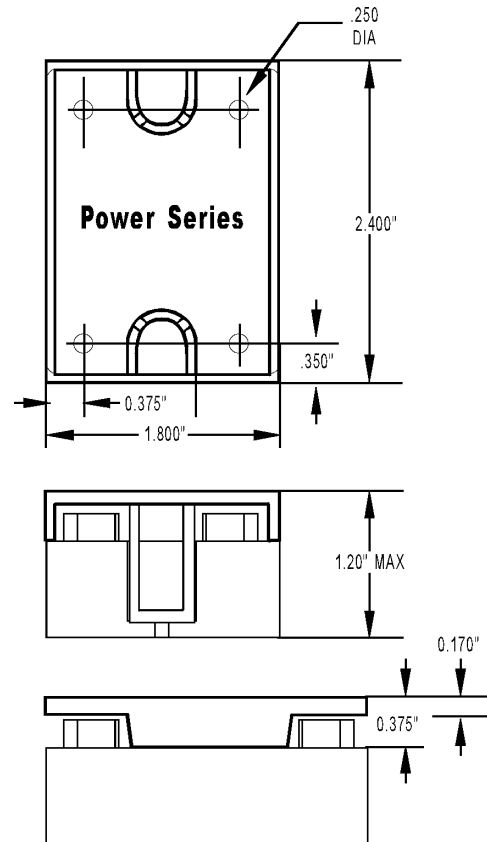

- Guards against accidental terminal contact
- Fits all Power Series SSRs
- Easy snap-on mounting
- Clear material and test probe holes — meet VDC specifications
- Part Number: SAFETY COVER

DATA SHEET

Form 859-000511

Specifications

AC Power Series - 120/240 Volt

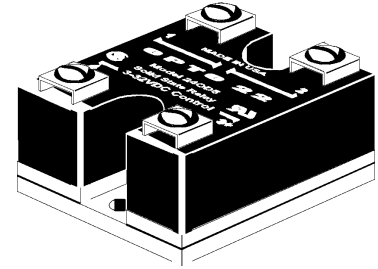

Opto 22 provides a full range of power series relays with a wide variety of voltage (110–575) and current options (3–45 amps). All Power Series relays feature 4,000 volts of optical isolation and have a high PRV rating.

Model Number	Nominal AC Line Voltage	Nominal Current Rating (Amps)	1 cycle Surge (Amps) Peak	Nominal Signal Input Resistance (Ohms)	Signal Pick-up Voltage	Signal Drop-out Voltage	Peak Repetitive Voltage Maximum	Maximum Output Voltage Drop	Off-State Leakage (mA) Maximum	Operating Voltage Range (Volts AC)	Pt Rating t=8.3 (ms)	Isolation Voltage	θ_{jc}^* ($^{\circ}$ C/Watt)	Dissipation (Watts/Amp)
120D3	120	3	85	1000	3VDC (32V allowed)	1 VDC	600	1.6 volts	2.5mA	12-140	30	4,000VRMS	11	1.7
120D10	120	10	110	1000	3VDC (32V allowed)	1 VDC	600	1.6 volts	7 mA	12-140	50	4,000VRMS	1.3	1.6
120D25	120	25	250	1000	3VDC (32V allowed)	1 VDC	600	1.6 volts	7 mA	12-140	250	4,000VRMS	1.2	1.3
120D45	120	45	650	1000	3VDC (32V allowed)	1 VDC	600	1.6 volts	7 mA	12-140	1750	4,000VRMS	0.67	0.9
240D3	240	3	85	1000	3VDC (32V allowed)	1 VDC	600	1.6 volts	5 mA	24-280	30	4,000VRMS	11	1.7
240D10	240	10	110	1000	3VDC (32V allowed)	1 VDC	600	1.6 volts	14 mA	24-280	50	4,000VRMS	1.3	1.6
240D25	240	25	250	1000	3VDC (32V allowed)	1 VDC	600	1.6 volts	14 mA	24-280	250	4,000VRMS	1.2	1.3
240D45	240	45	650	1000	3VDC (32V allowed)	1 VDC	600	1.6 volts	14 mA	24-280	1750	4,000VRMS	0.67	0.9
380D25	380	25	250	1000	3VDC (32V allowed)	1 VDC	800	1.6 volts	12 mA	24-420	250	4,000VRMS	1.2	1.3
380D45	380	45	650	1000	3VDC (32V allowed)	1 VDC	800	1.6 volts	12 mA	24-420	1750	4,000VRMS	0.67	0.9
120A10	120	10	110	33K	85 VAC (280 allowed)	10 VAC	600	1.6 volts	7 mA	12-140	50	4,000VRMS	1.3	1.6
120A25	120	25	250	33K	85 VAC (280 allowed)	10 VAC	600	1.6 volts	7 mA	12-140	250	4,000VRMS	1.2	1.3
240A10	240	10	110	33K	85 VAC (280 allowed)	10 VAC	600	1.6 volts	14 mA	24-280	50	4,000VRMS	1.3	1.6
240A25	240	25	250	33K	85 VAC (280 allowed)	10 VAC	600	1.6 volts	14 mA	24-280	250	4,000VRMS	1.2	1.3
240A45	240	45	650	33K	85 VAC (280 allowed)	10 VAC	600	1.6 volts	14 mA	24-280	1750	4,000VRMS	0.67	0.9

Notes: θ_{jc}^* = Thermal resistance junction to base. Maximum junction temperature is 110°C.

DATA SHEET

Form 859-000511

Specifications:
AC Power Series - 120/240 Volt (Continued)

Surge Current Data

Time (Seconds)	Time* (Cycles)	3-Amp Peak Amps	10-Amp Peak Amps	25-Amp Peak Amps	45-Amp Peak Amps
0.017	1	85	110	250	650
0.050	3	66	85	175	420
0.100	6	53	70	140	320
0.200	12	45	60	112	245
0.500	30	37	50	80	175
1	60	31	40	67	134
2	120	28	33	53	119
3	180	27	32	49	98
4	240	26	31	47	95
5	300	25	30	45	91
10	600	24	28	42	84

Note: *60 Hz.

Dimensional Drawings

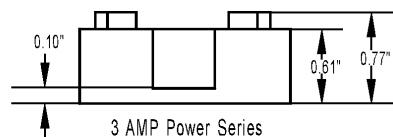
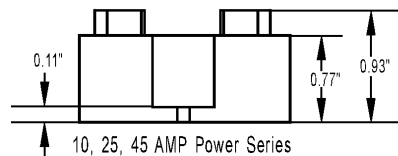
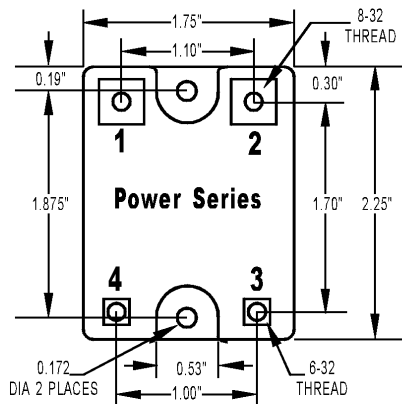

Thermal Ratings

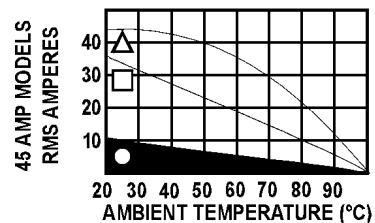
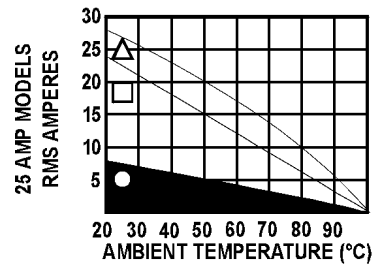
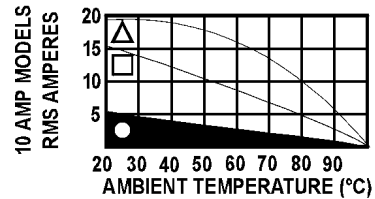
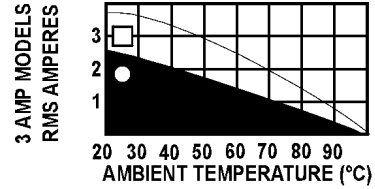

- FREE AIR
- MOUNTED ON 6" X 6" PLATE (2°c/watt)
- MOUNTED ON 12" X 12" PLATE (1°c/watt)

DATA SHEET

Form 859-000511

Specifications

AC Power Series - 480/575 Volt

DC SERIES: The DC Series delivers isolated DC control to large OEM customers worldwide.

AC SERIES: The AC Series offers the ultimate in solid-state reliability. All AC power series relays feature a built-in snubber and zero voltage turn-on. Transient proof models offer self-protection for noisy electrical environments.

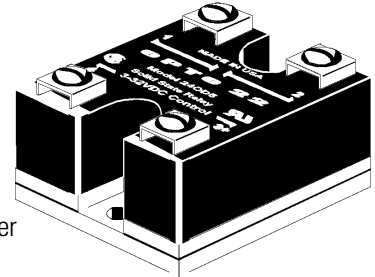

Model Number	Nominal AC Line Voltage	Nominal Current Rating (Amps)	1 cycle Surge (Amps) Peak	Nominal Signal Input Resistance (Ohms)	Signal Pick-up Voltage	Signal Drop-out Voltage	Peak Repetitive Voltage Maximum	Maximum Output Voltage Drop	Off-State Leakage (mA) Maximum	Operating Voltage Range (Volts AC)	Pt Rating t=8.3 (ms)	Isolation Voltage	θjc* (°C/Watt)	Dissipation (Watts/Amp)
480D10-12	480	10	110	1000	3VDC (32V Allowed)	1 VDC	1200	3.2 volts	11 mA	100-530	50	4,000V _{RMS}	1.2	2.5
480D15-12	480	15	150	1000	3VDC (32V Allowed)	1 VDC	1200	3.2 volts	11 mA	100-530	50	4,000V _{RMS}	1.2	2.5
480D25-12	480	25	250	1000	3VDC (32V Allowed)	1 VDC	1000	1.6 volts	11 mA	100-530	250	4,000V _{RMS}	1.3	1.3
480D45-12	480	45	650	1000	3VDC (32V Allowed)	1 VDC	1000	1.6 volts	11 mA	100-530	1750	4,000V _{RMS}	0.67	0.9
575D15-12	575	15	150	1000	3VDC (32V Allowed)	1 VDC	1200	3.2 volts	15 mA	100-600	90	4,000V _{RMS}	1.2	2.5
575D45-12	575	45	650	1000	3VDC (32V Allowed)	1 VDC	1000	1.6 volts	15 mA	100-600	1750	4,000V _{RMS}	0.67	0.9

Note: θjc* = Thermal resistance junction to base. Maximum junction temperature is 110°C.

Dimensional Drawings

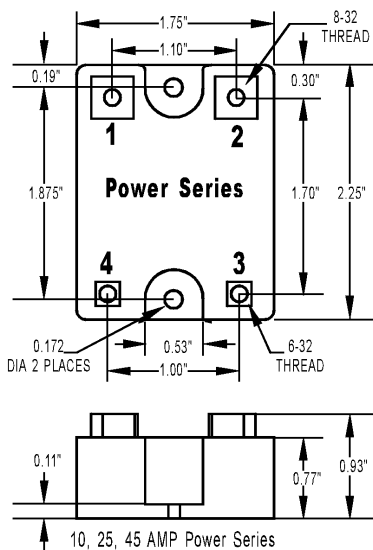

Thermal Ratings

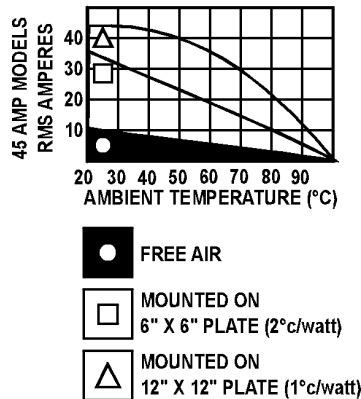

Surge Current Data

Time Second	Time*** (Cycles)	10-Amp Peak Amps	15-Amp Peak Amps	25-Amp Peak Amps	45-Amp Peak Amps
0.017	1	110	150	250	650
0.050	3	85	140	175	420
0.100	6	70	110	140	320
0.200	12	60	90	112	245
0.500	30	50	70	80	175
1	60	40	55	67	134
2	120	33	49	53	119
3	180	32	47	49	98
4	240	31	43	47	95
5	300	30	40	45	91
10	600	28	35	42	84

Note: ***60 Hz

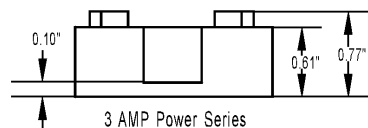

DATA SHEET

Form 859-000511

Specifications

AC Power Series - 120/240 Volt Plastic Package (z series)

The Z Series employs a unique heat transfer system that makes it possible for Opto 22 to deliver a low-cost, 10-amp, solid-state relay in an all-plastic case. The push-on tool-free quick-connect terminals make the Z Series ideal for high-volume OEM applications.

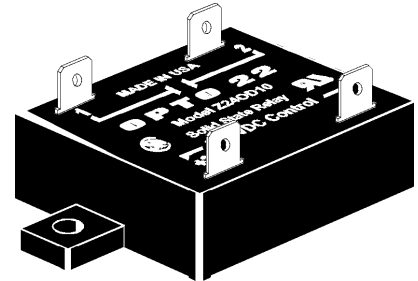

Model Number	Nominal AC Line Voltage	Nominal Current Rating (Amps)	1 cycle Surge (Amps) Peak	Nominal Signal Input Resistance (Ohms)	Signal Pick-up Voltage	Signal Drop-out Voltage	Peak Repetitive Voltage Maximum	Maximum Output Voltage Drop	Off-State Leakage (mA) Maximum	Operating Voltage Range (Volts AC)	Pt Rating t=8.3 (ms)	Isolation Voltage	θjc* (°C/Watt)	Dissipation (Watts/Amp)
Z120D10	120	10	110	1000	3VDC (32V allowed)	1 VDC	600	1.6 volts	6 mA	12-140	50	4,000 VRMS	4	1
Z240D10	240	10	110	1000	3VDC (32V allowed)	1 VDC	600	1.6 volts	12 mA	24-280	50	4,000 VRMS	4	1

Notes: θjc* = Thermal resistance junction to base. Maximum junction temperature is 110°C.

Dimensional Drawings

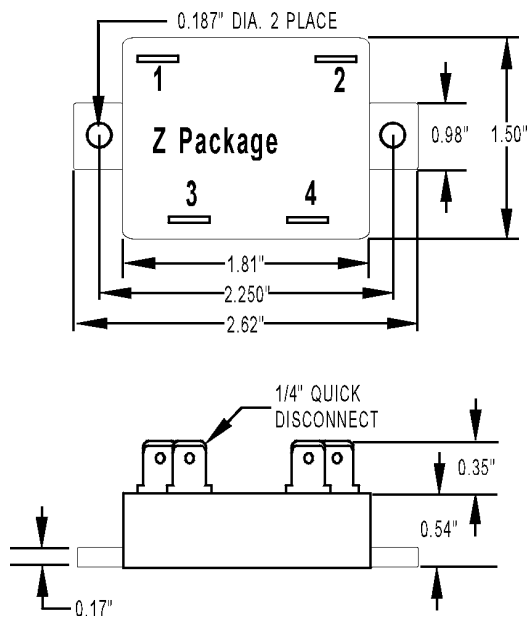

Current vs. Ambient Ratings

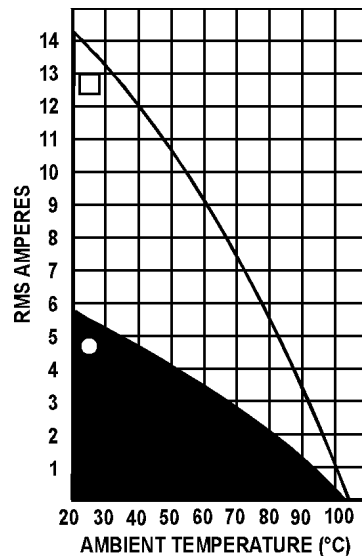

Surge Current Data

Time Second	Time*** (Cycles)	Peak Amps
0.017	1	110
0.050	3	85
0.100	6	70
0.200	12	60
0.500	30	50
1	60	40
2	120	33
3	180	32
4	240	31
5	300	30
10	600	28

Note: ***60 Hz



DATA SHEET

Form 859-000511

Specifications

AC Power - Printed Circuit Package (P & MP Series)

Model Number	Nominal AC Line Voltage	Nominal Current Rating Amps	1 cycle Surge (Amps) Peak	Nominal Signal Input Resistance (Ohms)	Signal Pick-up Voltage	Signal Drop-out Voltage	Peak Repetitive Voltage Maximum	Maximum Output Voltage Drop	Off-State Leakage mA Maximum	Operating Voltage Range (Volts AC)	Pt Rating $t=8.3$ (ms)	Isolation Voltage	θ_{jc}^* °C/Watt	Dissipation Watts/Amp
MP120D2 or P120D2	120	2	20	1000	3VDC** (32V allowed)	1 VDC	600	1.6 volts	5 mA	12-140	2	4,000 V _{RMS}	20	1.2
MP120D4 or P120D4	120	4	85	1000	3VDC** (32V allowed)	1 VDC	600	1.6 volts	5 mA	12-140	30	4,000 V _{RMS}	6.5	1.2
MP240D2 or P240D2	240	2	20	1000	3VDC** (32V allowed)	1 VDC	600	1.6 volts	5 mA	24-280	2	4,000 V _{RMS}	20	1.2
MP240D4 or P240D4	240	4	85	1000	3VDC** (32V allowed)	1 VDC	600	1.6 volts	5 mA	24-280	30	4,000 V _{RMS}	6.5	1.2
MP380D4	380	4	85	1000	3VDC** (32V allowed)	1 VDC	800	1.6 volts	5 mA	24-420	30	4,000 V _{RMS}	6.5	1.2

Notes: θ_{jc}^* = Thermal resistance junction to base. Maximum junction temperature is 110°C.
** = MP Series 24 volts maximum.

Dimensional Drawings

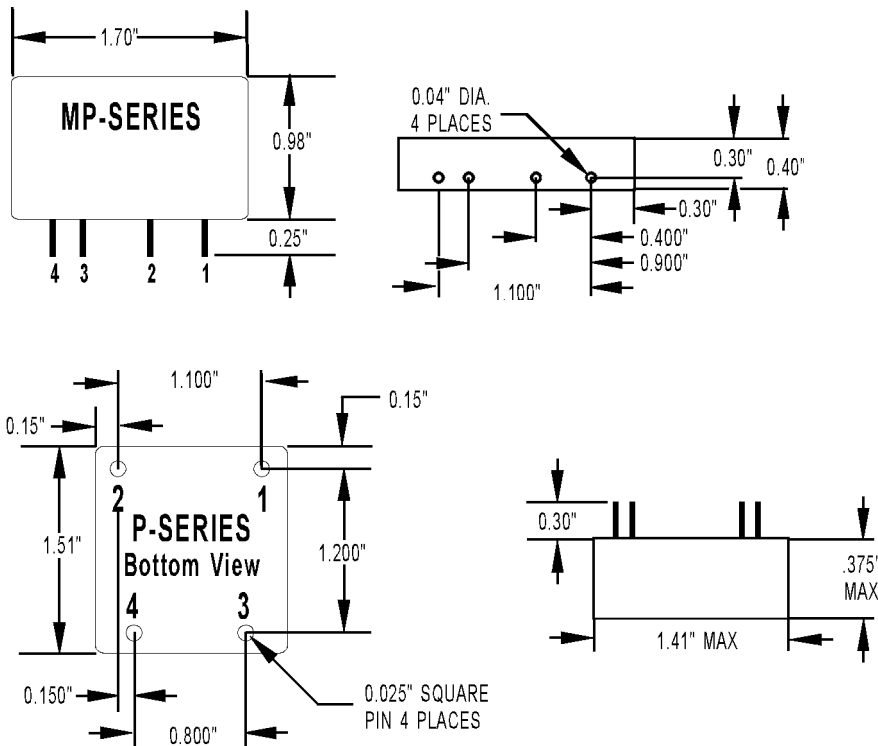

Model MP240D4

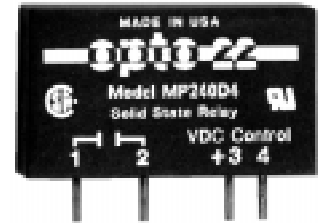

Model P240D4

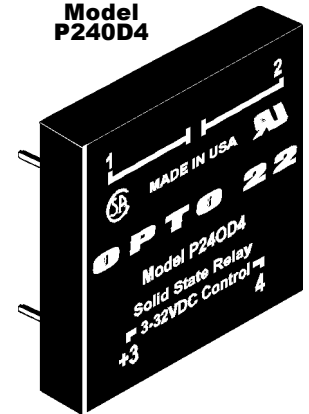

Form 859-000511

Specifications

AC Power - Printed Circuit Package (P & MP Series)

Thermal Ratings

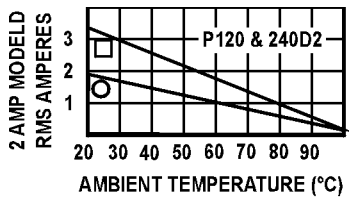
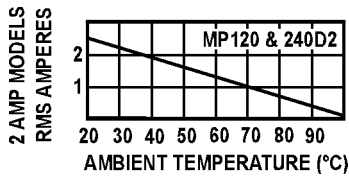

- FREE AIR
- MOUNTED ON 6" X 6" PLATE (2° C/WATT)

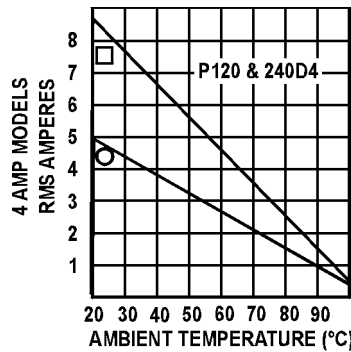
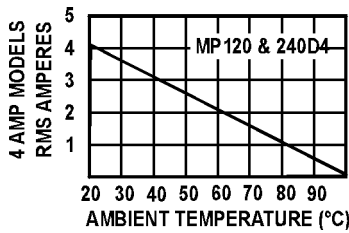

- FREE AIR
- MOUNTED ON 6" X 6" PLATE (2° C/WATT)

Surge Current Data

Time Second	Time* (Cycles)	Peak Amps	Peak Amps
0.017	1	20	85
0.050	3	18	66
0.100	6	15	53
0.200	12	11	45
0.500	30	9	37
1	60	8.5	31
2	120	8	28
3	180	7.5	27
4	240	7	26
5	300	6.5	25
10	600	6	24

Note: *60 Hz

OPTO 22

DATA SHEET

SOLID-STATE RELAYS

Form 859-000511

Description

DC Switching Series

MP Series

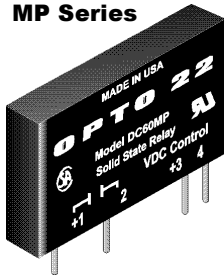

P Series

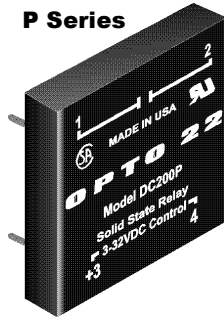

Power Series

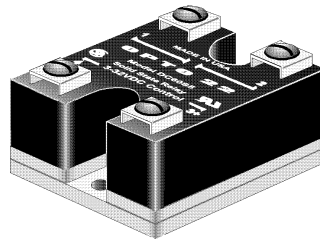

Thermal Ratings

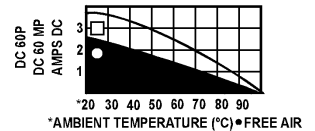
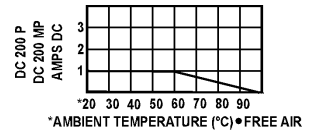

Specifications

	DC60P or DC60MP	DC200P or DC200MP	DC60S-3	DC60S-5
Operating Voltage Range	5-60 VDC	5-200 VDC	5-60 VDC	5-60 VDC
Forward Voltage Drop	1.5 volts at 3 amps	1.5 volts at 1 amp	1.5 volts at 3 amps	1.5 volts at 5 amps
Nominal Current Rating	3 amps	1 amp	3 amps	5 amps
Off-State Blocking	60 VDC	250 VDC	60 VDC	60 VDC
Signal Pickup Voltage	3 VDC 32 Volts* allowed	3 VDC 32 Volts* allowed	3 VDC 32 Volts allowed	3 VDC 32 Volts allowed
Signal Dropout Voltage	1 VDC	1 VDC	1 VDC	1 VDC
Signal Input Impedance	1,000 ohms	1,000 ohms	1,000 ohms	1,000 ohms
1 Second Surge	5 amps	2 amps	5 amps	10 amps
Operating Temp. Range	-40° C to 100° C	-40° C to 100° C	-40° C to 100° C	-40° C to 100° C
Isolation Voltage	4,000 VRMS	4,000 VRMS	4,000 VRMS	4,000 VRMS
Off-state Leakage	1 mA maximum	1 mA maximum	1 mA maximum	1 mA maximum
Package Type	P/MP series	P/MP series	Power series	Power series

Note: *MP series maximum allowed control signal 24 VDC.

Dimensional Drawings

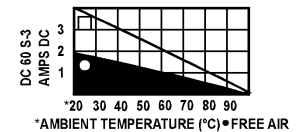
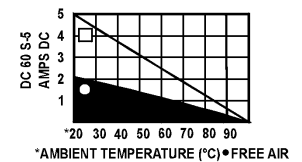
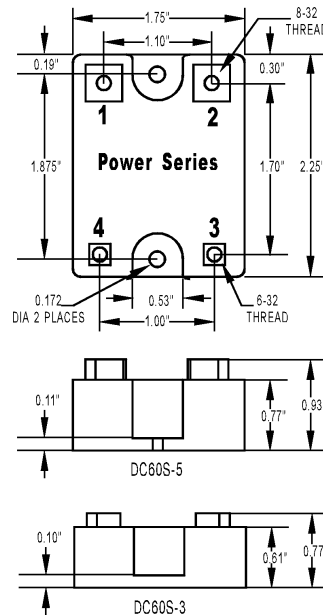

● FREE AIR
□ 2° C/WATT HEAT SINK (6" X 6" PLATE)

Dimensional Drawings

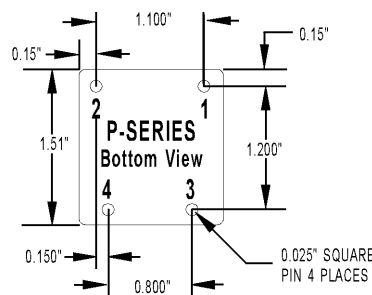
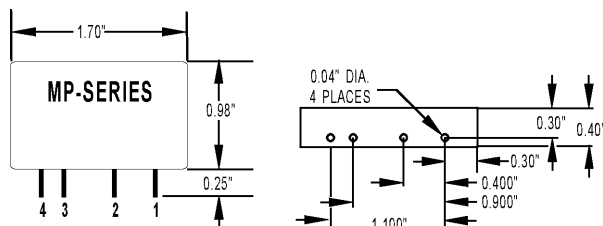

Form 859-000511

Applications

Tips

Heat Sink Calculation

Like all semiconductor devices, SSR current ratings must be based on maximum junction temperature. All Opto 22 SSRs operate conservatively at maximum junction temperatures of 110° C. Determining an adequate heat sink for a given SSR conducting a given current is very simple.

Note: Thermally conductive grease must be used between the relay base and the heat sink.

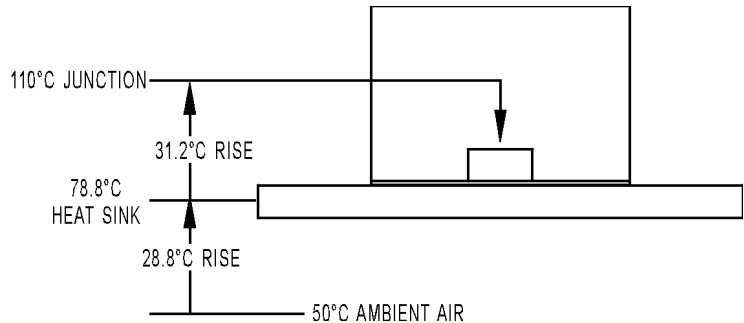

Sample Calculation Given:

120-Volt, 20-Amp Load
50° C Ambient Air

Choose Model 120D25 SSR.

Calculate dissipation as: **20 amps x 1.3 Watts per amp = 26 Watts**

Calculate temperature rise junction to SSR base as: **26 Watts x 1.2° C per Watt = 31.2° C**

Calculate allowable temperature of heat sink by subtracting 31.2° C from 110° C allowable junction temperature:

$$110^{\circ} \text{ C} - 31.2 = 78.8^{\circ} \text{ C}$$

The heat sink is in a 50° C ambient, therefore, allowable temperature rise on heat sink is: **78.8° C - 50° C = 28.8° C**

If heat sink is allowed to rise 28.8° C above ambient, then the thermal resistance of the heat sink is simply the 28.8° C rise divided by the 26 Watt. Any heat sink having a thermal resistance less than 1.1° C per Watt will be adequate.

Duty Cycle Calculation

When solid-state relays are operated in an on/off mode, it may be advantageous to calculate the RMS value of the current through the SSR for heat sinking or determining the proper current rating of the SSR for the given application.

I_{RMS} = RMS value of load or SSR
 T_1 = Time current is on
 T_2 = Time current is off
 I_{ON} = RMS value of load current during on period

$$I_{RMS} = \sqrt{\frac{(I_{ON})^2 \times T_1}{T_1 + T_2}}$$

Form 859-000511

Applications

Tips (Continued)

Transformer Loads

Careful consideration should be given to the selection of the proper SSR for driving a given transformer. Transformers are driven from positive saturation of the iron core to negative saturation of the core each ½ cycle of the alternating voltage. Large inrush currents can occur during the first ½ cycle of line voltage when a zero voltage SSR happens to turn on during the positive ½ cycle of voltage when the core is already in positive saturation. Inrush currents greater than 10 times rated transformer current can easily occur. The following table provides a guide for selecting the proper SSR for a given transformer rating.

120-Volt Transformers	
SSR MODEL	TRANSFORMER
P or MP 120D2	100 VA
Z120D10	500 VA
120D3	100 VA
P or MP 120D4	250 VA
120D10 or 120A10	500 VA
120D25 or 120a25	1 KVA
120D45	2 KVA
240-Volt Transformers	
P or MP240D2	200 VA
7240D10	1 KVA
120D3	200 VA
P or MP240D4	500 VA
240D10 or 240A10	1 KVA
240D25 or 240A25	2 KVA
240D45	4 KVA
480-Volt Transformers	
SSR MODEL	TRANSFORMER
480D10-12	5-Amp Primary
480D15-12	5-Amp Primary

Solenoid Valve and Contactor Loads

All Opto 22 SSRs are designed to drive inductive loads such as solenoid valves and electromechanical contactors. The built-in snubber in each SSR assures proper operation into inductive loads. The following table is a guide in selecting an SSR to drive a solenoid or contactor.

120-Volt Coils		
SSR CURRENT RATING	SOLENOID	CONTACTOR
2-Amp	1-Amp	NEMA Size 4
4-Amp	3-Amp	NEMA Size 7
240-Volt Coils		
SSR CURRENT RATING	SOLENOID	CONTACTOR
2-Amp	1-Amp	NEMA Size 7
4-Amp	3-Amp	NEMA Size 7

Control Current Calculation

All Opto 22 DC controlled SSRs have a control circuit consisting of 1000 ohms in series with an LED. Since 3 volts is required to turn on any SSR, the maximum current required is (3 volt - 1 volt) divided by 1000 ohms which equals 2.0 mA. The 1 volt is subtracted from the 3 volt signal because 1 volt is dropped across the LED. For higher control voltages, an external resistor can be added in series with the control voltage to limit the control current. To limit the control current to 2 mA, calculate the external resistor $R_c = 500 (E_c - 3)$ where E_c = the control voltage.

The DC control voltage range is 3–32 VDC. To calculate the control current for any voltage within the 3–32 VDC range, use the formula:

$$I_c = \frac{E_c - 1}{1000}$$

where R_c = zero.

With a 5V control signal,

$$I_c = \frac{5 - 1}{1000} = 4 \text{ mA.}$$

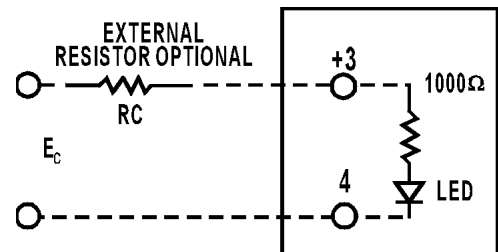

Form 859-000511

Applications

Tips (Continued)

Solid-State Relays In Series

In applications requiring greater current rating at higher voltage, two Opto 22 SSRs may be operated in series for double the voltage rating. The built-in snubber in each SSR assures proper voltage sharing of the two SSRs in series. In the diagram below, two 240-volt, 45-amp SSRs are connected in series for operation on a 480-volt line. The control is shown with a parallel hook-up but it should be noted that a serial connection can also be implemented.

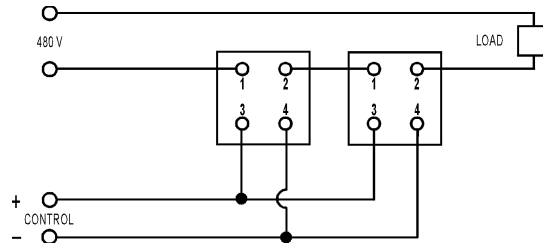

Lamp Loads

Since all Opto 22 SSRs are zero voltage switching, they are ideal for driving incandescent lamps because the initial inrush current into a cold filament is reduced. The life of the lamp is increased when switched by a zero voltage turn on SSR. The following table is a guide to selecting an Opto 22 SSR for switching a given incandescent lamp.

120 Volt Lamps	
SSR CURRENT RATING	LAMP RATING
2-Amp	100 Watt
4-Amp	400 Watt
10-Amp	1 Kilowatt
25-Amp	2 Kilowatt
45-Amp	3 Kilowatt
240 Volt Rating	
SSR CURRENT RATING	LAMP RATING
2-Amp	200 Watt
4-Amp	800 Watt
10-Amp	2 Kilowatt
25-Amp	4 Kilowatt
45-Amp	6 Kilowatt

Heater Loads

Care should be taken in selecting a SSR for driving a heater load if the load is cycled on and off in a continuous manner as might occur in a temperature control application. Constant cycling can cause thermal fatigue in the thyristor chip at the point where the chip bonds to the lead frame. Opto 22 employs a thick copper lead frame for mounting the SCR chips in the power series SSRs to eliminate thermal fatigue failures. In addition, Opto 22 recommends operating any SSR at 75% rated current for cycling heater loads to ensure complete reliability.

The following table is a guide to selecting the proper SSR for a given heater load.

Nominal SSR Current Rating	Maximum Recommended Heater Current
2-Amp	1½-Amp
4-Amp	2½-Amp
10-Amp	7½-Amp
25-Amp	18-Amp
45-Amp	35-Amp
10 480V	8-Amp
10 480V	8-Amp

Form 859-000511

Applications

Tips (Continued)

Single-Phase Reversing Motor Control

The circuit diagram illustrates a typical 1 Ø motor winding inductance and the phase shift capacitor can cause twice line voltage to appear across the open SSR. A 240-volt SSR should be used for a 120-Volt line. During the transition period when one SSR is turned on and the other SSR is going off, both SSRs may be on. In this case, the capacitor may discharge through the two SSRs, causing large currents to flow, which may destroy the SSRs. The addition of RL as shown will protect the SSRs from the short circuit capacitor discharge current.

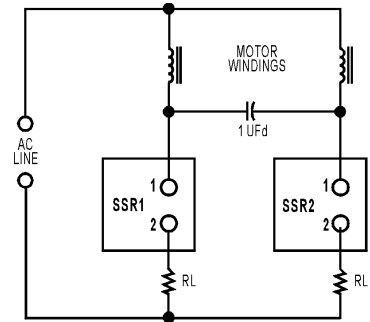

The resistors are unnecessary if the control circuit is designed to ensure one SSR is off before the other SSR is on.

CALCULATE RL as:
$$RL = \frac{1.4 \text{ EAC}}{10 \times \text{SSR full load rating}}$$

**EXAMPLE: 10 amp SSR
120 V AC Line**

$$RL = \frac{1.4 \times 120}{10 \times 10} = 1.7 \text{ ohm}$$

Three-Phase Motor Control

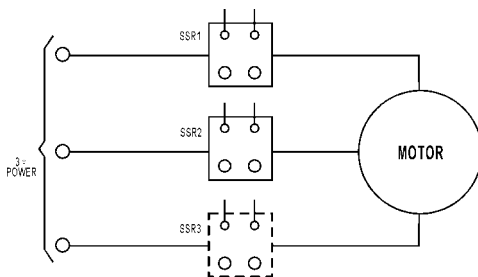

Three-phase motors may be controlled by solid-state relays as shown. A third SSR as shown is optional, but not necessary. The control windings may be connected in series or parallel. Care should be taken to ensure that surge current drawn by the motor does not exceed surge current rating of the SSR.

240-Volt 3Ø Motors	
SSR MODEL	MOTOR
Z240D25	1/3 HP
Z240D10	3/4 HP
240D10	3/4 HP
240A10	3/4 HP
240D25	2 HP
240A25	2 HP
240D45	3 HP
480-Volt 3Ø Motors	
SSR MODEL	MOTOR
480D10-12	1-½ HP
480D15-12	1-½ HP

Three-Phase Reversing Motor Control

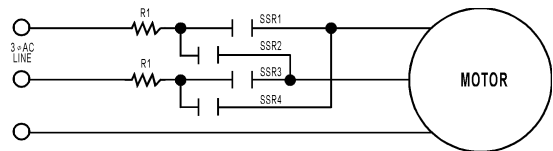

Three-phase reversing motor control can be implemented with four SSRs as shown in the connection diagram. The SSRs work in pairs with SSR1 and SSR3 operated for rotation in one direction and SSR2 and SSR4 operated for rotation in the reverse direction. The resistor R1 as shown in the connection diagram protects against line-to-line shorts if SSR1 and SSR4 or SSR3 and SSR2 are on at the same time during the reversing transition period. Use the following table as a guide to the proper selection of an SSR for this application.

Opto 22 Relay	Motor Full Load Rating	Resistor for 120V line	Resistor for 240V line
3-Amp	1.25-Amp	4 ohm 50 W	8 ohm 50 W
10-Amp	5-Amp	1 ohm 100 W	2 ohm 100 W
25-Amp	8-Amp	.5 ohm 100 W	1 ohm 100 W
45-Amp	16-Amp	.25 ohm 150 W	.5 ohm 150 W
15-Amp	5-Amp	1 ohm 100 W	2 ohm 100 W

Form 1291-010501

Description

The **SNAP Ultimate brain** is the powerful I/O and communications processor at the core of the SNAP Ultimate I/O™ system from Opto 22. As an evolutionary step in Opto 22's proven SNAP Ethernet I/O™ technology for connecting I/O systems to standard Ethernet networks, SNAP Ultimate I/O brings increased processing power, programmability, networking capability, and enterprise connectivity to the I/O level itself.

This extra intelligence, programmability, and connectivity significantly simplifies your control system design and expands the range of application solutions you can deliver. Besides running control programs right at the I/O level and eliminating the need for separate controllers, the SNAP Ultimate brain also has the ability to simultaneously communicate with multiple devices using Modbus/TCP, SNMP, SMTP, and other protocols.

The SNAP Ultimate brain streamlines and simplifies the delivery of data to your enterprise databases and other information technology (IT) systems. In place of the special software, proprietary servers, and other middleware components usually needed to move factory data into enterprise systems, the SNAP Ultimate brain delivers this data directly to these systems using the widely accepted Extensible Markup Language (XML), a data exchange language that enterprise systems already understand.

The connectivity with standard TCP/IP Ethernet networks first introduced with SNAP Ethernet I/O also applies to the SNAP Ultimate brain. You can attach a SNAP Ultimate brain to existing Ethernet networks, making it easy to add monitoring and control capabilities. Or you can use standard Ethernet hardware to build an independent control network, connecting your PC directly to I/O.

Communication with a SNAP Ultimate brain can also be established via a modem connection using Point-to-Point Protocol (PPP). Wireless or wireline modem connections are ideal for remote locations where an Ethernet network is not practical.

The compact Ultimate brain interfaces with a mix of Opto 22 SNAP I/O™ analog, digital, serial, and PID modules. The brain includes 16 MB of RAM, 8 MB flash memory, and a battery-backed real-time clock to time stamp e-mail messages and data logs.

(Continued on next page)

Part Number	Description
SNAP-UP1-ADS	Analog/Digital/Serial Ultimate Brain
ULTIMATEIODOCS	Printed Document Set for SNAP Ultimate I/O Systems



Features

- 16 MB RAM, 8 MB flash memory
- 10/100 Mbps Fast Ethernet network connectivity
- Programmable using included ioControl™ flowchart-based control software
- Simultaneous communication using Modbus/TCP, XML, SNMP, SMTP, and other application-level protocols
- Compatible with standard Ethernet technology and legacy SNAP I/O hardware.

Form 1291-010501

Description (continued)

Used with standard SNAP B-series mounting racks and SNAP I/O modules, the brain is the core of a powerful and sophisticated I/O and communication handling system. Built-in functions of the SNAP Ultimate brain include the following:

- **Digital**—Input latching, on/off status, watchdog timer, and event/reactions. The brain also includes counters and quadrature counters.
- **Analog**—Thermocouple linearization (32-bit floating point for linearized values), minimum/maximum values, offset and gain, scaling, time-proportional output, filter weight, and watchdog timer.

Using SNAP I/O special-purpose modules such as the SNAP-SCM-232 serial module or the SNAP-PID-V PID module, SNAP

Ultimate brain functions include the following:

- **Serial**—Send and receive ASCII strings to and from attached serial devices, such as chart recorders and barcode readers.
- **PID**—Monitor input signals and adjust output signals to control one proportional-integral-derivative (PID) loop.

Programming Options

The SNAP Ultimate brain is programmed using **ioControl™**, a graphical, flowchart-based programming tool for machine control and process applications. ioControl is used to create, download, and run control programs, or *strategies*, on the brain, and is included in the purchase price of the SNAP Ultimate brain. Online

(Continued on next page)

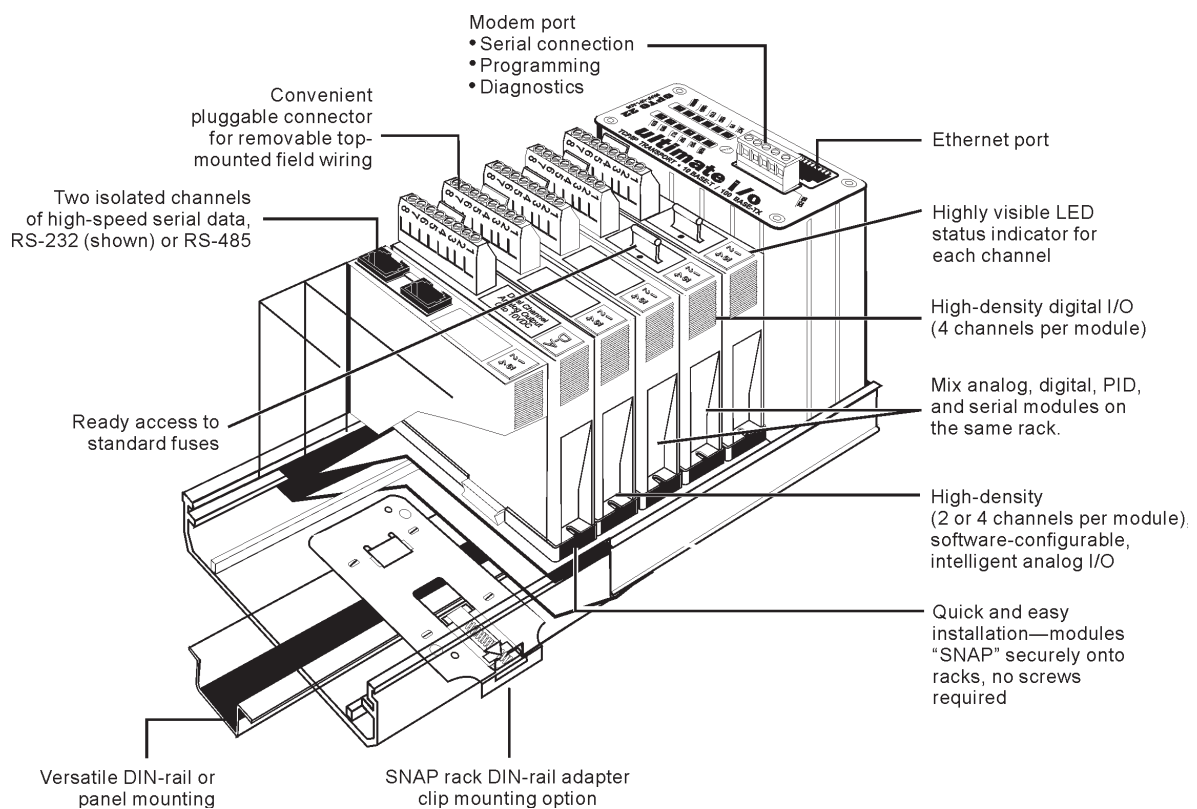

Form 1291-010501

Description (continued)

documentation and sample files are included with the software; printed documentation can be purchased for \$99 US.

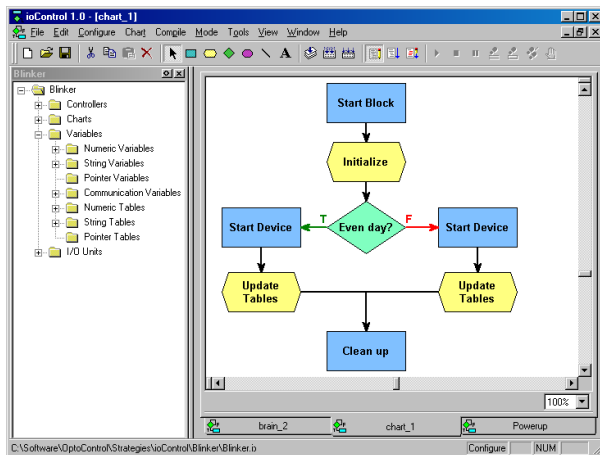

A flowchart-based control strategy in ioControl

In addition to its flowchart-based programming that lets you write control strategies visually, key features that make ioControl easy to use include:

- A **Strategy Tree** that provides a graphical view of your entire control system configuration, including I/O points and variables
- **OptoScript**, a powerful built-in scripting language based on C and other procedural programming languages
- An animated **debugger** for stepping through a control program in real time.

ioControl has a similar look and feel to Opto 22's established OptoControl™ flowchart-based development environment and will be familiar to OptoControl users. However, ioControl is designed for use solely with SNAP Ultimate I/O systems, and cannot use control strategies developed in OptoControl.

Also available for use with the brain is **ioDisplay™**, an HMI and trending software application for building operator interfaces for your Microsoft® Windows®-based clients. ioDisplay can be purchased for \$99 US. See Opto 22 form 1296, the ioDisplay data sheet, for more information.

The SNAP Ultimate brain also supports the *event/reactions* first made available in SNAP Ethernet brains. Event/reactions are

configured using a Web browser and Web pages installed on your PC; no additional software is needed. (ioControl is needed to create control strategies.) The SNAP Ultimate brain has the same event/reaction capabilities as the SNAP Ethernet brain.

For setup and diagnostics, the SNAP Ultimate brain is easily configured using just a standard Web browser and Web pages installed on your PC. Two levels of security are available to limit access to the brain as necessary. Both data streaming and data logging are also supported.

The SNAP Ultimate brain provides both 10 and 100 Mbps Fast Ethernet compatibility, with automatic speed negotiation and a standard RJ-45 twisted-pair connector. Both 10Base-T and 100Base-TX are supported. The brain also includes a serial port for modem communication, programming, and diagnostics.

Utilities for use with the SNAP Ultimate brain, including a BootP utility for assigning IP addresses, are available from the Product Support section of our Web site at www.opto22.com/support.

Communication Options

You can use any of the following methods—or all of them simultaneously—to interface with one or more SNAP Ultimate brains and I/O, using the RJ-45 or RS-232 connections:

- **Opto 22 ioControl and ioDisplay**—Create and download control programs with ioControl, and monitor and control the brain using an operator interface built with ioDisplay.
- **XML support**—I/O data is made available via XML for direct delivery to XML-ready enterprise applications such as databases, MRP, ERP, and other applications running on multiple computer platforms.
- **Modbus/TCP driver**—for interfacing with any third-party software or hardware that uses the Modbus/TCP protocol.
- **SNMP messaging**—for communicating with SNMP-based enterprise management software such as Computer Associates' Unicenter TNG® or Hewlett Packard's OpenView®.

(Continued on next page)

Form 1291-010501

Description (continued)

- **OPC2.0 server**—providing OLE for Process Control (OPC) 2.0 access for OPC clients.
- **Opto 22's IEEE 1394-based memory map protocol**—for writing your own applications. This protocol is open and documented, and sample utilities with source code are available to get you started. You can also stream data from the brain using this protocol.
- **SNAP Ethernet I/O Driver Toolkit**—an easier, faster way to program applications for SNAP Ethernet and SNAP Ultimate brains. It includes an ActiveX® component and a C++ class, which hide the details of Ethernet communications and the memory map protocol.
- **Linux®/UNIX® support**—Demo utilities with source code are available.

I/O Mounting Racks

SNAP Ultimate brains are connected to SNAP B-series I/O mounting racks, which are available with 4, 8, 12, or 16 positions for Opto 22 SNAP I/O modules. Analog, serial, and PID communication modules can be placed in any position on a B-series rack; digital modules can be placed in any of the first eight positions. (A maximum of eight serial modules or 12 PID modules can be used on a rack.) Because of the rack's flexibility in handling digital, analog, and special-purpose modules in many of the same positions, you can install the modules that fit your needs.

Each SNAP digital module contains four input or four output points. SNAP analog modules used with the SNAP Ultimate brain contain either two points or four points, depending on the module. SNAP serial communication modules provide two serial ports to connect serial devices to the Ethernet network.

SNAP Ultimate I/O System Architecture

The diagram below and the diagrams on the following page show sample architectures for the SNAP Ultimate I/O system.

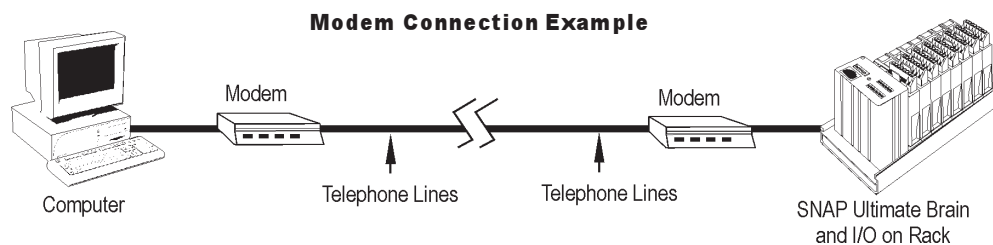

Single I/O Unit Configuration Example

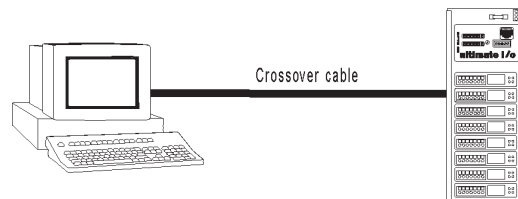

SNAP Ultimate I/O System Architecture (continued)

SNAP Ultimate Brain and Multiple I/O Units Configuration Example

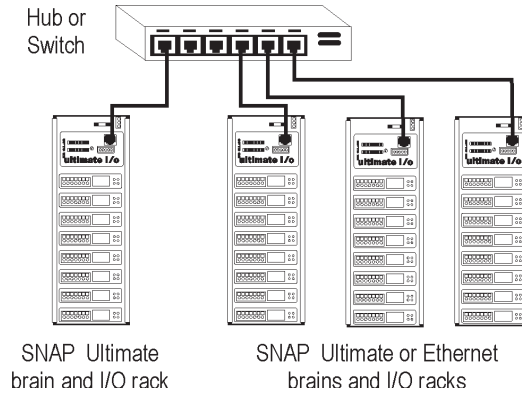

Network Configuration Example

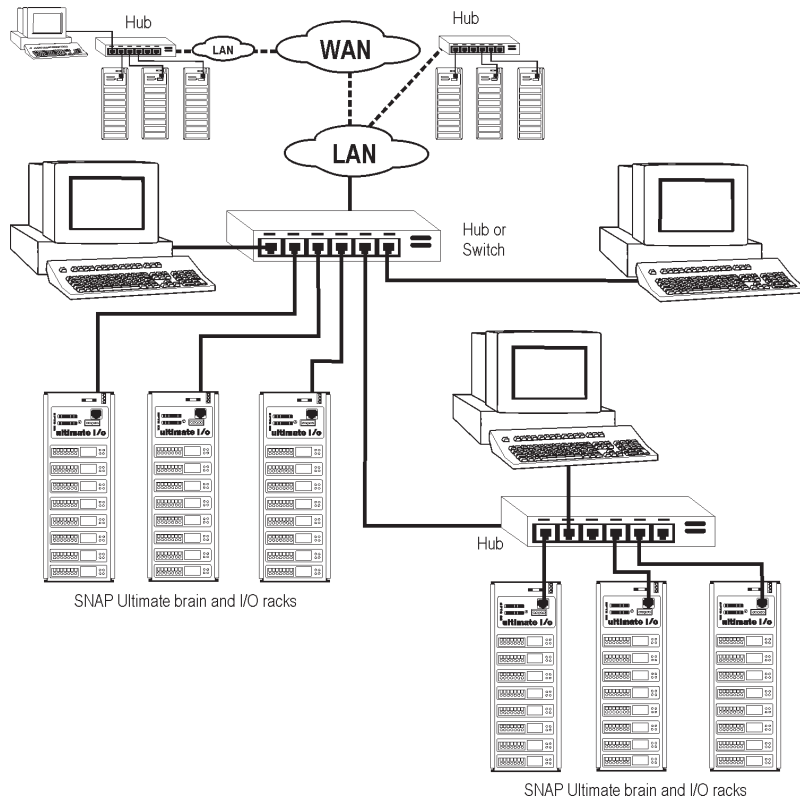

DATA SHEET

Form 1291-010501

Specifications

Power Requirements	5.0 VDC ± 0.1 VDC at 1.0 A maximum (does not include SNAP I/O module power requirements)
Operating Temperature	0° C to 60° C
Storage Temperature	-40° C to 85° C
Humidity	0–95% humidity, non-condensing
Memory	16 MB RAM, 8 MB flash memory
Network Interface	IEEE 802.3 network, 10Base-T and 100Base-TX
Serial Port	RS-232
Serial Data Rates	Default is 19,200 kBd; baud rate is soft-selectable from 2400 to 115,200 kBd.
Maximum Ethernet Segment Length	100 meters with Category 5 or superior UTP. For 100 Mbps at this distance, use Category 5 solid UTP.
Jumpers (Internal)	Boot to kernel/boot to loader Reset to factory defaults

Top View: SNAP Ultimate Brain

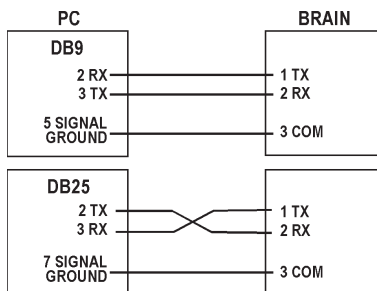

Serial Connector Pinouts

Pin	RS-232
1	TX
2	RX
3	COM
4	RTS
5	CTS

For future use

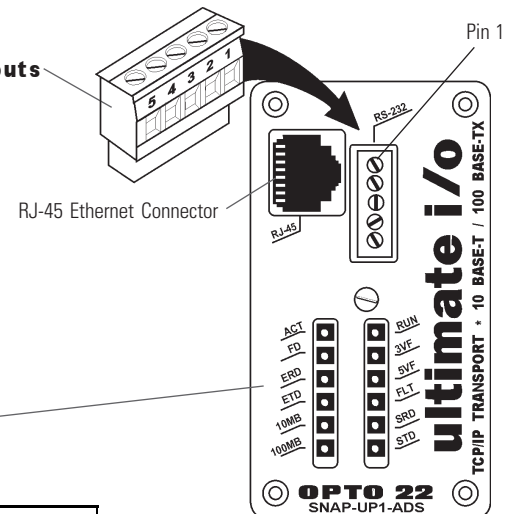

LED Descriptions

LED	Description	LED	Description
ACT	Network Activity	RUN	Normal Operation
FD	Full Duplex Mode	3VF	3 Volt Fault
ERD	Ethernet—Receive Data	5VF	5 Volt Fault
ETD	Ethernet—Transmit Data	FLT	Microprocessor Fault
10MB	Ethernet Link Detection at 10 Mbps	SRD	Serial—Receive Data
100MB	Ethernet Link Detection at 100 Mbps	STD	Serial—Transmit Data

Form 1291-010501

Dimensions

The dimensions of the SNAP Ultimate brain are identical to those of the SNAP-B3000-ENET or SNAP-ENET-D64 Ethernet brains.

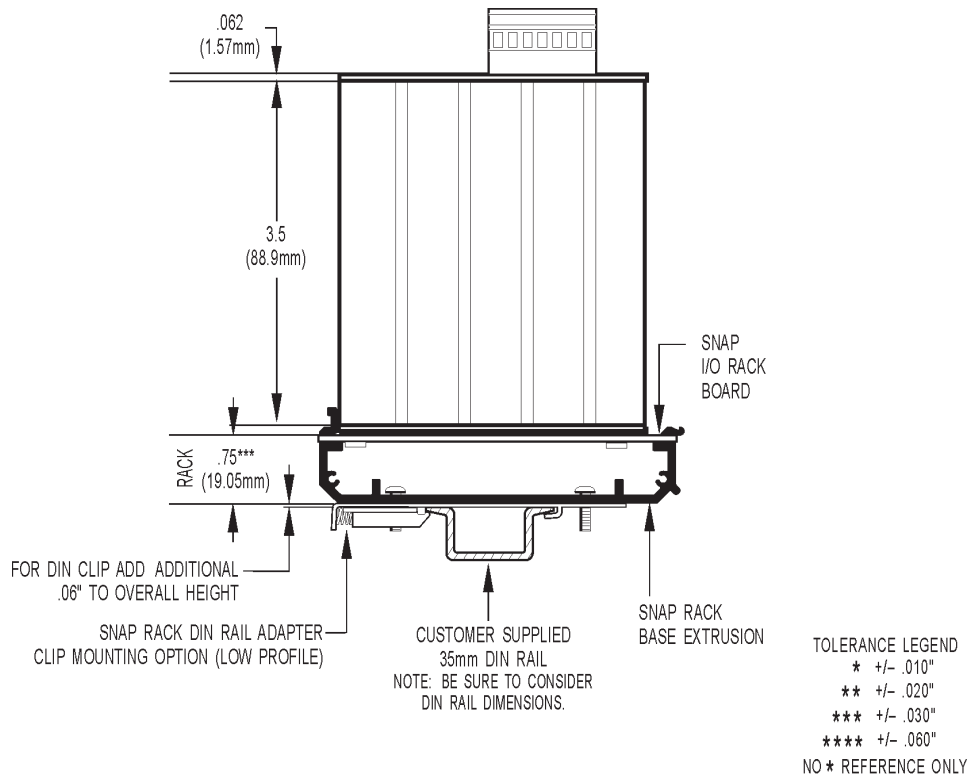
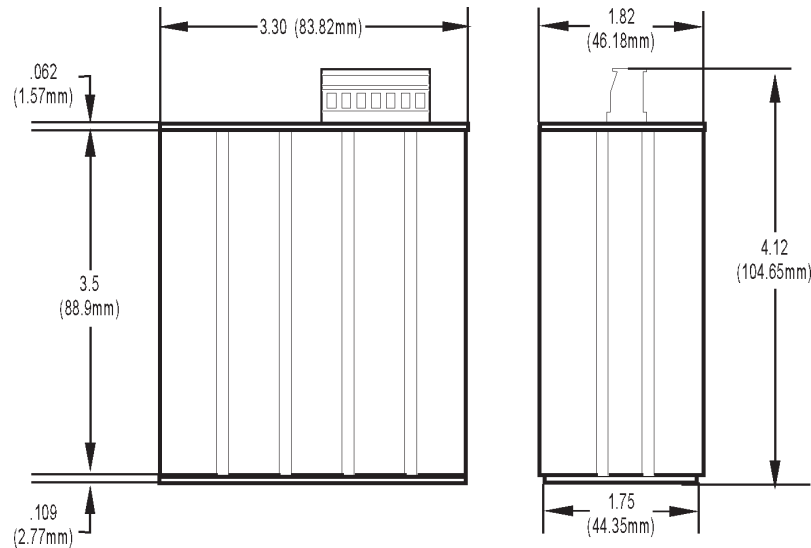

DATA SHEET

Form 1296-010501

Part Number	Description
IODISPLAY	Software for creating and running a human-machine interface (HMI)

Description

Opto 22's ioDisplay™ is an intuitive HMI package for building operator interfaces for your Microsoft® Windows®-based clients communicating with Opto 22 SNAP Ultimate I/O™ systems. For just \$99 per seat, ioDisplay offers a full-featured HMI including alarming, trending, and a built-in library of 3,000 industrial automation graphics.

The power of ioDisplay lies in its close integration with Opto 22's powerful SNAP Ultimate I/O system. SNAP Ultimate I/O is the first input/output (I/O) system to combine I/O, control, Ethernet networking, and direct communication with enterprise systems, all in a single distributed package. See Opto 22 form #1291 for more information on SNAP Ultimate I/O and the SNAP Ultimate brain.

ioDisplay monitors SNAP Ultimate I/O hardware to give operators, technicians, and engineers the information they need at a glance, while transferring operator instructions to the control hardware. ioDisplay also archives and displays data trends and handles alarms.

Integration

Designed to take full advantage of Opto 22's guaranteed-for-life SNAP I/O™ modules and the most advanced I/O system in the world, SNAP Ultimate I/O, ioDisplay offers a cost-effective HMI when you need an interface for technicians and operators.

The SNAP Ultimate I/O system is programmed using ioControl™, a graphical, flowchart-based programming tool for machine control and process applications. When you build a control application using ioControl, a plain-English, long-tagname database is created. Once I/O points and variables are named and defined, they are stored in the OptoControl database and referenced by name. This database is shared with ioDisplay, thereby eliminating duplicate databases and tagname-related errors.

Ease of Use

With ioDisplay, you construct your operator interface, or *project*, by designing graphical objects. Onscreen windows can combine pictures, symbols, bitmaps, and 3-D graphics. You can create graphics using built-in drawing tools, import them from other applications, or select them from the Symbol Factory, ioDisplay's extensive library of industrial automation graphics. Displays can also include hardware-driven animations and operator-driven commands.

Developing ioDisplay projects is easy—just point, click, and associate. You can animate any

Typical ioDisplay Screen

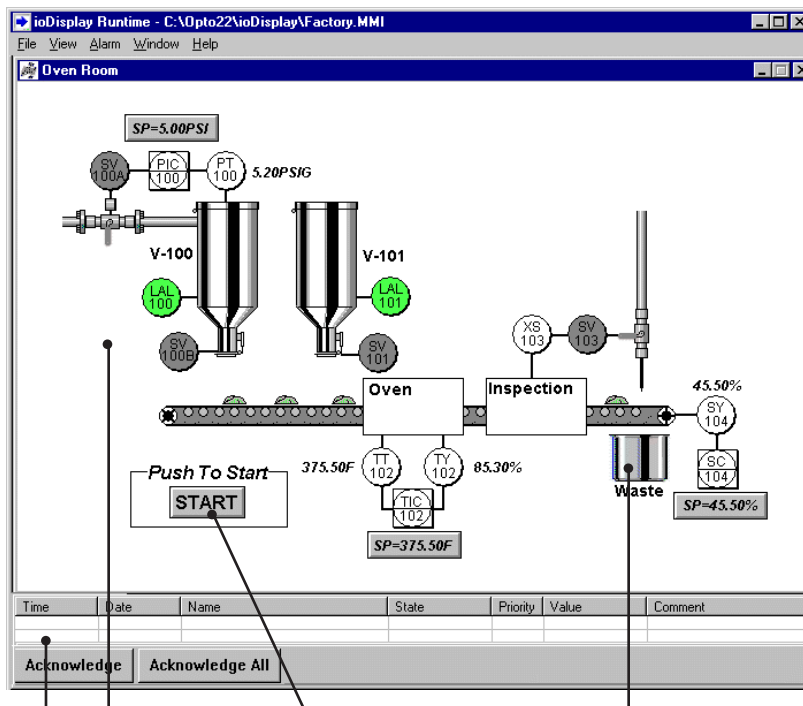

Multiple on-screen windows present operator and process information.

Operator-driven on-screen objects such as buttons and sliders can be easily added to the display.

Use a preconfigured graphic object from the included symbols or built-in Symbol Factory, or import custom bitmaps from your own application.

DATA SHEET

Form 1296-010501

graphical control object and associate it with real-world events by choosing a tagname from the shared ioControl database. Simply use your mouse to select the items you want from the ioControl strategy and associate them with your ioDisplay graphical objects or historical collection files.

SuperTrends

With the SuperTrends feature in ioDisplay, you can plot trends using real-time data, historical data, or both, switching between current data and previously logged data with the click of a button.

With 16 available pens, you can plot 16 variables or I/O points per trend window. Point markers show you when data is actually sampled. For historical data, you can just click on a point to see the exact date, time, and value when the data was scanned.

You can zoom in or out on the x-axis to see a larger or smaller time span for the trend, and the y-axis scaling can be changed in real time for any pen. If the computer running the ioDisplay project doesn't have a mouse or you prefer not to use one, you can configure hot keys to provide control from the keyboard alone.

Alarming

You can view and acknowledge alarms in ioDisplay, as well as see an alarm history for each alarm point. You can determine which alarm points to set up, define alarm thresholds, and choose colors for alarm states. Sound files can be added, and comments or messages can be displayed in alarm graphics while ioDisplay is running.

An automatic response to an alarm can be set up to provide immediate action, such as automatically closing a valve when a specific alarm goes off. You can also set priorities for alarms, so that an operator can choose to receive only higher priority alarms during startup, for example. As with trending, hot keys can be set up for mouse-free acknowledgment of alarms.

In addition, you can send the historical log of all alarms to a printer and also to a user-configurable ASCII text file that can be easily imported for analysis into Microsoft Excel, Access, or other applications.

For more information on ioDisplay or SNAP Ultimate I/O, contact Opto 22 Inside Sales at the phone number listed at the bottom of this page.

ioDisplay SuperTrend Screen

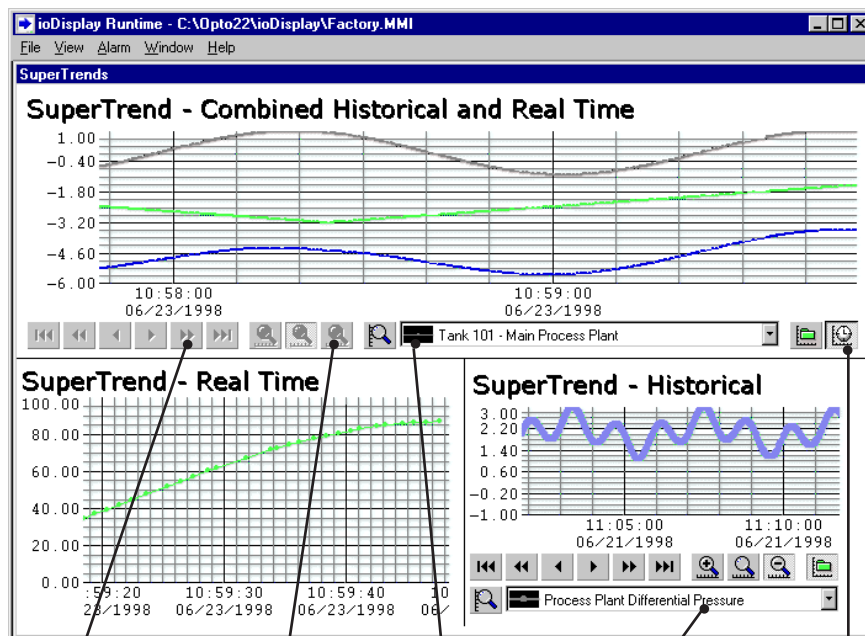

Scroll backward and forward in historical log files.

Zoom in and out along the x-axis.

Adjust y-axis scaling for the active pen.

Select the active pen.

Select real-time or historical mode.

Price Listing

OPTO 22		
ITEM	DESCRIPTION	1 TO 9
120A10	120 VAC, 10 AMP, AC CONTROL	19.00
120A25	120 VAC, 25 AMP, AC CONTROL	21.00
120D10	120 VAC, 10 AMP, DC CONTROL	16.00
120D25	120 VAC, 25 AMP, DC CONTROL	20.00
120D3	120 VAC, 3 AMP, DC CONTROL	12.50
120D45	120 VAC, 45 AMP, DC CONTROL	30.00
240A10	240 VAC, 10 AMP, AC CONTROL	18.50
240A25	240 VAC, 25 AMP, AC CONTROL	26.00
240A45	240 VAC, 45 AMP, AC CONTROL	34.00
240D10	240 VAC, 10 AMP, DC CONTROL	19.00
240D10-17	240 VAC, 10 AMP, DC CONTROL, VDE APPROVED	21.00
240D25	240 VAC, 25 AMP, DC CONTROL	22.00
240D25-17	240 VAC, 25 AMP, DC CONTROL, VDE APPROVED	24.00
240D3	240 VAC, 3 AMP, DC CONTROL	13.00
240D45	240 VAC, 45 AMP, DC CONTROL	31.00
240D45-17	240 VAC, 45 AMP, DC CONTROL, VDE APPROVED	33.00
240D45-18	POWER SERIES VDE COUPLR 700PRV	34.00
380D25	380 VAC, 25 AMP, DC CONTROL	30.00
380D45	380 VAC, 45 AMP, DC CONTROL	52.00
480D10-12	480 VAC, 10 AMP, DC CONTROL, TRANSIENT PROOF	28.00
480D15-12	480 VAC, 15 AMP, DC CONTROL, TRANSIENT PROOF	30.00
480D25-12	480 VAC, 25 AMP, DC CONTROL, TRANSIENT PROOF	28.00
480D45-12	480 VAC, 45 AMP, DC CONTROL, TRANSIENT PROOF	32.00
575D15-12	575 VAC, 15 AMP, DC CONTROL, TRANSIENT PROOF	36.00
575D25-E	POWER SERIES HIGH VOLTAGE SSR	27.00
575D45-12	575 VAC, 45 AMP, DC CONTROL, TRANSIENT PROOF	33.00
AC24AT	ISA BUS SERIAL PORT RS422/485, ISOLATED	190.00
AC28	ISA BUS TO PAMUX BUS ADAPTER	170.00
AC30A	RS485 MULTIDROP REPEATER 120 VAC	105.00
AC30B	RS485 MULTIDROP REPEATER 220 VAC	105.00
AC31A	ADDRESSABLE RS232 INTERFACE 120 VAC	295.00
AC31B	ADDRESSABLE RS232 INTERFACE 220 VAC	295.00
AC31C	ADDRESSABLE RS232 INTERFACE DC	295.00
AC36	MULTIBUS TO PAMUX BUS ADAPTER	120.00
AC37	ISA BUS HIGH SPEED SERIAL CO-PROCESSOR, RS485	550.00
AC38A	HIGH SPEED RS485 REPEATER 120 VAC	365.00
AC38B	HIGH SPEED RS485 REPEATER 220 VAC	365.00
AC39	ISA BUS TO LOCAL BUS ADAPTER-AT	395.00
AC40A	FIBER OPTIC REPEATER, 120 VAC	550.00
AC40B	FIBER OPTIC REPEATER, 240 VAC	550.00
AC40C	FIBER OPTIC REPEATER, 24 VDC	590.00
AC42	ISA BUS FIBER OPTIC SERIAL CO-PROCESSOR	550.00
AC422AT	ISA BUS SERIAL PORT RS422/485, NON-ISOLATED	155.00
AC47	DUAL TWISTED PAIR ARCNET	315.00
AC5	ISA BUS TO CARD EDGE I/O RACK WITH 6-FT CABLE	140.00
AC7	RS232 TO 422/485 CONVERTER	85.00
AC7A	RS232-RS422/485 CONVERTER 120V	105.00
AC7B	RS232-RS422/485 CONVERTER 220V	105.00
AC8	HALF DUPLEX MODEM INTERFACE	170.00
AC8A	HALF DUPLEX MODEM INTERFACE 120 VAC	250.00
AC8B	HALF DUPLEX MODEM INTERFACE 220 VAC	250.00
AD10T2	100 OHM RTD INPUT ISOLATED	120.00
AD11	-5 TO +5 VDC INPUT	65.00
AD11T	-5V TO +5V INPUT ISOLATED	100.00
AD12	-10 TO +10 VDC INPUT	65.00
AD12T	+10V TO -10V INPUT ISOLATED	100.00
AD13T	0 TO 100 MV INPUT ISOLATED	120.00
AD14T	10 OHM RTD INPUT ISOLATED	120.00
AD15T	28 TO 140 VAC INPUT ISOLATED	100.00
AD16T	0 - 5 AMP INPUT ISOLATED	120.00
AD17T	TYPE R OR S THERMOCOUPLE INPUT ISOLATED	120.00
AD18T	T THERMOCOUPLE INPUT ISOLATED	120.00
AD19T	TYPE E THERMOCOUPLE INPUT ISOLATED	120.00
AD20	0 TO 10.8KHZ RATE INPUT	120.00
AD2T	0 TO 20 MA INPUT ISOLATED	100.00
AD3	4 TO 20 MA INPUT	45.00
AD3T	4 TO 20 MA INPUT ISOLATED	100.00
AD4	ICTD INPUT	60.00
AD5	J THERMOCOUPLE INPUT	100.00
AD5T	J THERMOCOUPLE INPUT ISOLATED	120.00
AD6	0 TO +5 VDC INPUT	55.00
AD6HS	0 TO +5 VDC INPUT-HIGH SPEED	55.00
AD6T	0 TO +5 VDC INPUT ISOLATED	100.00
AD7	0 TO +10 VDC INPUT	55.00
AD8	K THERMOCOUPLE INPUT	100.00
AD8T	K THERMOCOUPLE INPUT ISOLATED	120.00
AD9T	0 TO 50 MV INPUT ISOLATED	120.00
B1	16-CHANNEL DIGITAL BRAIN OPTOMUX PROTOCOL	221.00
B100	16-CHANNEL DIGITAL BRAIN MISTIC	240.00
B2	16-CHANNEL ANALOG BRAIN OPTOMUX PROTOCOL	225.00
B200	16-CHANNEL ANALOG BRAIN MISTIC	250.00
B3000	SNAP ANALOG/DIGITAL BRAIN MISTIC/OPTOMUX PROTOCOL	425.00
B3000-HA	HIGH SPEED SNAP ANALOG/DIGITAL BRAIN MISTIC/OPTOMUX PROTOCOL WITH ARCNET/5 POS CONN VEF	550.00
B4	32-CHANNEL DIGITAL BRAIN PAMUX	158.00
B5	16-CHANNEL DIGITAL BRAIN PAMUX	151.00
B6	16-CHANNEL ANALOG BRAIN PAMUX	310.00
BD-DEVNET	16-CHANNEL DIGITAL BRAIN DEVICENET	295.00
BRACKET	BRACKET P RELAY R1001	1.25
BRICKSTRAP	BUS BAR FOR BRICK BASE	5.00
CA10	10-FT CABLE EDGE TO EDGE	60.00
CA2	2-FT CABLE EDGE TO EDGE	36.00
CA4	4-FT CABLE EDGE TO EDGE	42.00
CA6	6-FT CABLE EDGE TO EDGE	48.00
CA8	8-FT CABLE EDGE TO EDGE	54.00
CJC	COLD JUNCTION COMPENSATOR	10.00
CYRANO 200	SOFTWARE-MISTIC 200 PROCESSOR	#####
CYRANO 200 MANL	CYRANO 200 MANUAL	100.00
DA3	4-20 MA OUTPUT	95.00
DA3T	4-20 MA OUTPUT ISOLATED	105.00
DA4	0 TO +5 VDC OUTPUT	95.00
DA4T	0 TO 5 VDC OUTPUT ISOLATED	105.00
DA5	0 TO +10 VDC OUTPUT	95.00
DA6	-5 TO +5 VDC OUTPUT	110.00
DA7	-10 TO +10 VDC OUTPUT	110.00

Price Listing

ITEM	DESCRIPTION	1 TO 9
DA8	0-20 MA OUTPUT	95.00
DC200MP	MP MODEL, 200 VDC, 1 AMP, DC CONTROL	11.25
DC200P	P MODEL, 200 VDC, 1 AMP, DC CONTROL	11.25
DC60MP	MP MODEL, 60 VDC, 3 AMP, DC CONTROL	8.00
DC60P	P MODEL, 60 VDC, 3 AMP, DC CONTROL	8.00
DC60S3	60 VDC, 3 AMP, DC CONTROL	9.60
DC60S5	60 VDC, 5 AMP, DC CONTROL	15.00
EX1	PAMUX ADAPTER FOR LC4	140.00
EX2	SERIAL AND I/O RACK ADAPTER FOR LC4	140.00
FACTORY FLOOR MANUA	FACTORYFLOOR MANUAL SET	75.00
FACTORYFLOOR	FACTORYFLOOR SUITE	349.00
FUSE.125	1/8-AMP FUSE, ANALOG I/O CHANNEL	1.00
FUSE01	1-AMP FUSE G1 DIGITAL LOGIC POWER	1.00
FUSE01G4	1-AMP FUSE G4 DIGITAL RACK LOGIC POWER, BRICK REGULATOR	1.00
FUSE02	2 AMP FUSE FOR 32-CHANNEL DIGITAL LOGIC	1.00
FUSE05	5-AMP FUSE FOR STANDARD DIGITAL OUTPUT MODULES	1.00
FUSEG4	G4 4-AMP FUSE, R5026 TR5-F	1.00
G4 FUSE CLIP	G4 FUSE RETAINING CLIP 10 PACK	2.50
G4 FUSE SOCKETS	G4 FUSE SOCKET 100-PACK	7.00
G4-MOD-SOCKETS	G4 MODULE SOCKET 100-PACK	10.00
G4-PEM-NUTS	G4 PEM NUTS 100-PACK	10.00
G4A8R	REMOTE ANALOG 8-CHANNEL MULTIFUNCTION I/O UNIT MISTIC PROTOCOL	615.00
G4AC5	ISA BUS TO HEADER I/O RACK WITH 6-FT CABLE	140.00
G4AD10	100 OHMS PLATINUM RTD INPUT	125.00
G4AD11	-5 TO 5 VDC INPUT	117.00
G4AD12	-10 TO 10 VDC INPUT	117.00
G4AD13	0 TO 100 MV INPUT	125.00
G4AD16	0 TO +5 AMP AC/DC INPUT	167.00
G4AD17	TYPE R THERMOCOUPLE INPUT	125.00
G4AD18	TYPE T THERMOCOUPLE INPUT	125.00
G4AD19	TYPE E THERMOCOUPLE INPUT	125.00
G4AD20	0 TO 10.8KHZ RATE INPUT	150.00
G4AD22	0 TO 1 VOLT DC INPUT	117.00
G4AD23	TYPE S THERMOCOUPLE INPUT	125.00
G4AD24	TYPE B THERMOCOUPLE INPUT NO CJC REQD	125.00
G4AD25	0 TO 100 VOLT AC/DC INPUT	125.00
G4AD26	DV/DT INPUT MODULE	125.00
G4AD3	+4 TO +20 MA INPUT	100.00
G4AD4	ICTD TEMPERATURE INPUT	117.00
G4AD5	TYPE J THERMOCOUPLE INPUT	125.00
G4AD6	0 TO +5 VDC INPUT	117.00
G4AD6HS	0 TO +5 VDC INPUT HIGH SPEED	117.00
G4AD7	0 TO +10 VDC INPUT	117.00
G4AD7HS	0 TO +10 VDC INPUT HIGH SPEED	117.00
G4AD8	TYPE K THERMOCOUPLE INPUT	125.00
G4AD9	0 TO +50 MV INPUT	125.00
G4A1TM	16-CHANNEL INPUT THERMOCOUPLE/MILLIVOLT	#####
G4A1VA	16-CHANNEL INPUT VOLTAGE/CURRENT	995.00
G4AOA	16 PT. CURRENT OUTPUT	865.00
G4AOV	16 PT. VOLTAGE OUTPUT	725.00
G4B1	REMOTE DIGITAL 16-CHANNEL I/O UNIT OPTOMUX PROTOCOL	435.00
G4B2	REMOTE ANALOG 8-CHANNEL I/O UNIT OPTOMUX PROTOCOL	485.00
G4BATT32	3.6V BATTERY FOR CONTROLLER MEMORY	18.25
G4BRICKBASE	MOUNTING BASE FOR BRICK ASSEMBLY	75.00
G4D16L	LOCAL DIGITAL 16 CHANNEL MULTIFUNCTION I/O UNIT MISTIC PROTOCOL	615.00
G4D16LS	LOCAL DIGITAL 16 CHANNEL I/O UNIT MISTIC PROTOCOL	700.00
G4D16R	REMOTE DIGITAL 16-CHANNEL MULTIFUNCTION I/O UNIT MISTIC PROTOCOL	615.00
G4D32RS	REMOTE DIGITAL 32-CHANNEL I/O UNIT MISTIC PROTOCOL	450.00
G4DA10	TIMED PROPORTIONAL AC OUTPUT	100.00
G4DA3	+4 TO +20 MA OUTPUT	100.00
G4DA4	0 TO +5 VDC OUTPUT	117.00
G4DA5	0 TO +10 VDC OUTPUT	117.00
G4DA6	-5 TO +5 VDC OUTPUT	117.00
G4DA7	-10 TO +10 VDC OUTPUT	117.00
G4DA8	0 TO +20 MA OUTPUT	117.00
G4DA9	TIMED PROPORTIONAL DC OUTPUT	100.00
G4EXL	LOCAL ANALOG EXTENDER BRAIN CARD	85.00
G4EXR	REMOTE ANALOG EXTENDER BRAIN CARD	85.00
G4HDAR	REMOTE ANALOG 32-CHANNEL HIGH RESOLUTION MULTIFUNCTION I/O UNIT MISTIC PROTOCOL	685.00
G4IAC15	G4 AC INPUT 90-140 VAC, 15 VDC LOGIC	9.50
G4IAC15A	G4 AC INPUT 180-280VAC, 15 VDC LOGIC	10.50
G4IAC24	G4 AC INPUT 90-140 VAC, 24 VDC LOGIC	9.50
G4IAC24A	G4 AC INPUT 190-280 VAC, 24 VDC LOGIC	10.50
G4IAC5	G4 AC INPUT 90-140 VAC, 5 VDC LOGIC	9.50
G4IAC5A	G4 AC INPUT 180-280 VAC, 5 VDC LOGIC	10.50
G4IAC5MA	G4 AC INPUT 90-140 VAC, 5VDC LOGIC W/SW	21.00
G4IDC15	G4 DC INPUT 10-32 VDC, 15 VDC LOGIC	9.50
G4IDC24	G4 DC INPUT 10-32 VDC, 24 VDC LOGIC	9.50
G4IDC5	G4 DC INPUT 10-32 VDC, 5 VDC LOGIC	9.50
G4IDC5B	G4 DC INPUT 4-16 VDC, 5VDC LOGIC HIGH SPEED	13.00
G4IDC5D	G4 DC INPUT 2.5-28 VDC, 5 VDC LOGIC	8.50
G4IDC5G	G4 DC INPUT 35-60 VDC, 5 VDC LOGIC	9.50
G4IDC5K	G4 DC INPUT 2.5-16 VDC, 5 VDC LOGIC VERY HIGH SPEED	13.00
G4IDC5MA	G4 DC INPUT 10-32 VDC, 5 VDC LOGIC WITH HOA/SW	21.00
G4IDC5Q	G4 DC INPUT 2.5-16 VDC, 5 VDC LOGIC 2 CH QUADRATURE	195.00
G4IOR	REMOTE PANEL INTERFACE MISTIC PROTOCOL	62.00
G4LAX	LOCAL ANALOG 8 CHANNEL I/O UNIT EXTENDER	335.00
G4LC32	OPTO 22 CLASSIC CONTROLLER	#####
G4LC32ARC	CLASSIC ARCNET ADAPTER FOR G4LC32SX	270.00
G4LC32F1M	UPGRADE G4LC32 FLASH 4M	400.00
G4LC32ISA	OPTO 22 ISA CONTROLLER	#####
G4LC32ISA-LT	OPTO 22 ISA LITE CONTROLLER	635.00
G4LC32ISAARC	ISA ARCNET ADAPTER FOR G4LC32ISA	210.00
G4LC32ISAF1M	UPGRADE G4LC32ISA FLASH 4M	215.00
G4LC32ISASER	ISA SERIAL ADAPTER FOR G4LC32ISA	210.00
G4LC32RAMEX.5M	CLASSIC CONTROLLER (G4LC32) 1MB RAM EXPANSION KIT	280.00
G4LC32RAMEX2M	CLASSIC CONTROLLER (G4LC32) 2MB RAM EXPANSION KIT	#####
G4LC32RAMEX4M	CLASSIC CONTROLLER (G4LC32) 4MB RAM EXPANSION KIT	800.00
G4LC32SER	CLASSIC SERIAL ADAPTER FOR G4LC32SX	270.00
G4LC32SX	OPTO 22 CLASSIC SX CONTROLLER	#####
G4LC32SXF1M	UPGRADE G4LC32SX FLASH 4M	215.00
G4MSERVO	G4 MOTION SERVO	#####
G4OAC15	G4 AC OUTPUT 12-140 VAC, 15 VDC LOGIC	9.50
G4OAC15A	G4 AC OUTPUT 24-280 VAC, 15 VDC LOGIC	10.50
G4OAC24	G4 AC OUTPUT 12-140 VAC, 24 VDC LOGIC	9.50
G4OAC24A	G4 AC OUTPUT 24-280 VAC, 24 VDC LOGIC	10.50

Price Listing

ITEM	DESCRIPTION	1 TO 9
G4OAC5	G4 AC OUTPUT 12-140 VAC, 5 VDC LOGIC	9.50
G4OAC5A	G4 AC OUTPUT 24-280 VAC, 5 VDC LOGIC	10.50
G4OAC5A5	G4 AC OUTPUT, 24-280 VAC, 5 VDC LOGIC, NC	10.50
G4OAC5A5FM	G4 AC OUTPUT 24-280 VAC, 5 VDC LOGIC, NC, FM	11.50
G4OAC5AFM	G4 AC OUTPUT 24-280 VAC, 5 VDC LOGIC, FACTORY MUTUAL APPROVED	11.50
G4OAC5AMA	G4 AC OUTPUT 24-280 VAC, 5 VDC LOGIC WITH HOA/SW	21.00
G4OAC5FM	G4 AC OUTPUT 12-140 VAC, 5 VDC LOGIC, FM APPROVED	10.50
G4OAC5MA	G4 AC OUTPUT 12-140 VAC, 5 VDC LOGIC WITH HOA/SW	21.00
G4OAX	OPTOMUX ANALOG EXTENDER	335.00
G4ODC15	G4 DC OUTPUT 5-60 VDC, 15 VDC LOGIC	9.50
G4ODC24	G4 DC OUTPUT 5-60 VDC, 24 VDC LOGIC	9.50
G4ODC24A	G4 DC OUTPUT 5-200 VDC, 24 VDC LOGIC	15.40
G4ODC5	G4 DC OUTPUT 5-60 VDC, 5 VDC LOGIC	9.50
G4ODC5A	G4 DC OUTPUT 5-200 VDC, 5 VDC LOGIC	15.40
G4ODC5AFM	G4 DC OUTPUT 5-200 VDC, 5 VDC LOGIC, FM APPROVED	16.40
G4ODC5FM	G4 DC OUTPUT 5-60 VDC, 5 VDC LOGIC, FM APPROVED	10.50
G4ODC5MA	G4 DC OUTPUT 5-60 VDC, 5 VDC LOGIC WITH HOA/SW	21.00
G4ODC5R	G4 REED RELAY OUTPUT, 5 VDC LOGIC	10.50
G4ODC5R5	G4 REED RELAY OUTPUT, 5 VDC LOGIC, NC	10.50
G4ODC5R5FM	G4 REED RELAY OUTPUT, 5 VDC LOGIC, NC, FM APPROVED	11.50
G4ODC5R5FM	G4 REED RELAY OUTPUT, 5 VDC LOGIC, FM APPROVED	11.50
G4PB16	G4 16-CHANNEL I/O MODULE RACK	62.00
G4PB16H	G4 16-CHANNEL RACK W/HEADER CONNECTOR	69.00
G4PB16HC	G4 16-CHANNEL RACK W/HEADER CONNECTOR COMMON TB	147.00
G4PB16I	G4 16-CHANNEL I/O MODULE RACK ISOLATED CONTROL	80.00
G4PB16J	G4 DC INPUT 4-16VDC 16-CHANNEL INTEGRAL	175.00
G4PB16K	G4 DC INPUT 16-28VDC 16-CHANNEL INTEGRAL	175.00
G4PB16L	G4 DC OUTPUT 5-60VDC 16-CHANNEL INTEGRAL	190.00
G4PB16T	G4 16-CHANNEL I/O MODULE RACK EXTRA TERMINAL STRIP	80.00
G4PB24	G4 24-CHANNEL I/O MODULE RACK	97.00
G4PB32DEC	G4 32-CHANNEL I/O MODULE RACK	125.00
G4PB32H	G4 32-CHANNEL RACK W/HEADER CONNECTOR FOR B4 BRAIN	120.00
G4PB4	G4 4-CHANNEL I/O MODULE RACK	21.00
G4PB4R	G4 4-CHANNEL OUTPUT MODULE RACK	25.00
G4PB8	G4 8-POINT I/O RACK WITH HEADER CONN	38.00
G4PB8H	G4 8-POINT RACK W/HEADER CONN FOR BRAIN	42.00
G4PS245A	CLASSIC CONTROLLER POWER SUPPLY + 7 BRICKS 120VAC	450.00
G4PS245AFM	CLASSIC CONTROLLER POWER SUPPLY + 7 BRICKS 120VAC, FACTORY MUTUAL APPROVED	450.00
G4PS245B	CLASSIC CONTROLLER POWER SUPPLY + 7 BRICKS 220VAC	450.00
G4PS24XA	BRICK POWER SUPPLY 7 BRICKS 120 VAC	345.00
G4PS24XAFM	BRICK POWER SUPPLY 7 BRICKS 120 VAC FACTORY MUTUAL APPROVED	345.00
G4PS24XB	BRICK POWER SUPPLY 7 BRICKS 220 VAC	345.00
G4RA	REMOTE ANALOG 16 CHANNEL MULTIFUNCTION BRAIN MISTIC PROTOCOL	495.00
G4RAM1M	1 MB MEMORY EXPANSION RAM CHIP FOR FLASH BASED CONTROLLERS	50.00
G4RAM4M	4 MB MEMORY EXPANSION RAM CHIP FOR FLASH BASED CONTROLLERS	110.00
G4RAX	REMOTE ANALOG 8-CHANNEL I/O UNIT EXTENDER	335.00
G4RCOMMKIT	REMOTE BRICK COMMUNICATION KIT	142.00
G4RD	REMOTE DIGITAL 16-CHANNEL MULTIFUNCTION BRAIN MISTIC PROTOCOL	495.00
G4REG	BRICK POWER REGULATION MODULE	90.00
G4RPANEL	REMOTE BRICK PANEL KIT	290.00
G4RS	REMOTE DIGITAL 32-CHANNEL BRAIN MISTIC PROTOCOL	230.00
G4STRAP	G4 16-POSITION STRAP SINGLE RACK, R5187	8.95
G4SWIN	G4 INPUT SWITCH 5,15,24 VDC LOGIC	19.00
G4SWOUT	G4 OUTPUT SWITCH 250 VAC	19.00
G4TELEMETRY	MISTIC TELEMETRY EPROM & SOFTWARE	200.00
G4TERM	REMOTE BRICK TERMINATOR	35.00
HH1.5	1.5-FT HEADER TO HEADER CABLE	40.00
HH10	10-FT HEADER TO HEADER CABLE	64.00
HH4	4-FT HEADER TO HEADER CABLE	47.00
HH6	6-FT HEADER TO HEADER CABLE	54.00
HH8	8-FT HEADER TO HEADER CABLE	60.00
HHG4H2	PANEL TO PANEL HORIZONTAL LOCAL BRICK CABLE	21.00
HHG4V2	PANEL TO PANEL VERTICAL LOCAL BRICK CABLE	39.00
IAC15	AC INPUT 90-140 VAC, 15 VDC LOGIC	9.50
IAC15A	AC INPUT 180-280 VAC, 15 VDC LOGIC	10.50
IAC24	AC INPUT 90-140 VAC, 24 VDC LOGIC	9.50
IAC24A	AC INPUT 180-280 VAC, 24 VDC LOGIC	9.50
IAC5	AC INPUT 90-140 VAC, 5 VDC LOGIC	9.50
IAC5A	AC INPUT 180-280 VAC, 5 VDC LOGIC	10.50
IAC5AQ	4-CHANNEL AC INPUT 180-280 VAC, 5 VDC LOGIC	35.00
IAC5P	P MODEL AC INPUT 90-140 VAC, 5 VDC LOGIC	9.50
IAC5Q	4-CHANNEL AC INPUT 90-140 VAC, 5 VDC LOGIC	35.00
ICTD	TEMPERATURE PROBE	30.00
IDC15	DC INPUT 10-32 VDC, 15 VDC LOGIC	9.50
IDC24	DC INPUT 10-32 VDC, 24 VDC LOGIC	9.50
IDC5	DC INPUT 10-32 VDC, 5 VDC LOGIC	9.50
IDC5B	DC INPUT 4-16 VDC, 5 VDC LOGIC HIGH SPEED	13.00
IDC5BQ	4-CHANNEL DC INPUT 4-16 VDC, 5 VDC LOGIC, HIGH SPEED	45.00
IDC5D	DC INPUT 2.5-28 VDC, 5 VDC LOGIC	8.50
IDC5G	DC INPUT 35-60 VDC, 5 VDC LOGIC	9.50
IDC5P	P MODEL DC INPUT 10-32 VDC, 5 VDC LOGIC	9.50
IDC5Q	4-CHANNEL DC INPUT 10-32 VDC, 5 VDC LOGIC	35.00
INPUT SWITCH	INPUT SWITCH 5,15,24 VDC LOGIC	15.50
IODISPLAY	HMI SOFTWARE FOR SNAP-UP1-ADS PER PC	99.00
JUMPERS	JUMPERS, QTY 10	1.00
LC COMMUNICATOR	HAND HELD TERMINAL	325.00
LC4	OPTO 22 LC CONTROLLER	695.00
LC4A	OPTO 22 LC CONTROLLER 120 VAC	745.00
LC4B	OPTO 22 LC4 CONTROLLER 220 VAC	745.00
LC4DC	OPTO 22 LC CONTROLLER DC FILTER BOARD	745.00
LICENSE OPTO DISPLAY	OPTODISPLAY LICENSE ONLY	99.00
LICENSE OPTOCNTL	OPTOCONTROL LICENSE ONLY	99.00
LICENSE OPTOSERVER	OPTO SERVER LICENSE SINGLE SITE	99.00
M4	OPTO 22 MODULAR CONTROLLER	#####
M4 I/O	OPTO 22 MODULAR I/O CONTROLLER	#####
M4DUALARC	M4 DUAL ARCNET ADAPTER CARD	315.00
M4LCSX	UNAVAILABLE CNTRLR MODEL 400	
M4PS120A	MODULAR CONTROLLER AC POWER SUPPLY 90-130V	285.00
M4PS125D	MODULAR CONTROLLER DC POWER SUPPLY 125V	265.00
M4PS12D	MODULAR CONTROLLER DC POWER SUPPLY 9-15V	265.00
M4PS240A	MODULAR CONTROLLER AC POWER SUPPLY 180-250V	285.00
M4PS24D	MODULAR CONTROLLER DC POWER SUPPLY 18-35V	265.00
M4PS48D	MODULAR CONTROLLER DC POWER SUPPLY 36-60V	265.00
M4PSF	MODULAR CONTROLLER DC FILTER BOARD	145.00
M4RTU	OPTO 22 MODULAR RTU/DAS CONTROLLER	#####
M4RTUF1M	UPGRADE M4RTU FLASH 4M	215.00

Price Listing

ITEM	DESCRIPTION	1 TO 9
M4RTUX	OPTO 22 MODULAR CONTROLLER I/O EXTENDER	335.00
M4SARC	M4 ARCNET ADAPTER	210.00
M4SARCF	M4 ARCNET ADAPTER FIBER OPTIC	350.00
M4SARCFR	M4 ARCNET REPEATER FIBER OPTIC	450.00
M4SENET-100	100 BASE-TX M4 ETHERNET CARD	695.00
M4SENETC	M4 ETHERNET ADAPTER COAXIAL CABLE	595.00
M4SENETU	M4 ETHERNET ADAPTER UNSHEILDLED TWISTED PAIR	595.00
M4SSER	M4 SERIAL ADAPTER CARD	210.00
MDS	MISTIC DATA SERVER	995.00
MISC PART	ITEM DESCRIBED IN COMMENTS	0.00
MISTIC MMI	MISTIC 200 WINDOWS MMI	#####
MISTIC MMI/MDS	MISTIC 200 MMI AND MDS	#####
MP120D2	MP MODEL, 120 VAC, 2 AMP, DC CONTROL	8.50
MP120D4	MP MODEL, 120 VAC, 4 AMP, DC CONTROL	8.75
MP240D2	MP MODEL, 240 VAC, 2 AMP, DC CONTROL	9.15
MP240D4	MP MODEL, 240 VAC, 4 AMP, DC CONTROL	9.75
MP240D4-17	MP MODEL, 240 VAC, 4 AMP, DC CONTROL, VDE APPROVED	10.50
MP380D4	MP MODEL, 380 VAC, 4 AMP, DC CONTROL	10.50
OAC15	AC OUTPUT 12-140 VAC, 15 VDC LOGIC	9.50
OAC15A	AC OUTPUT 24-280 VAC, 15 VDC LOGIC	10.50
OAC24	AC OUTPUT 12-140 VAC, 24 VDC LOGIC	9.50
OAC24A	AC OUTPUT 24-280 VAC, 24 VDC LOGIC	10.50
OAC24H	AC OUTPUT 24-280 VAC, 24 VDC LOGIC, HIGH CURRENT	10.50
OAC5	AC OUTPUT 12-140 VAC, 5 VDC LOGIC	9.50
OAC5A	AC OUTPUT 24-280 VAC, 5 VDC LOGIC	10.50
OAC5A-11	AC OUTPUT MODULE NON ZERO CROSS	10.50
OAC5A5	AC OUTPUT 24-280 VAC, 5 VDC LOGIC, NC	10.50
OAC5P	P MODEL AC OUTPUT 12-140 VAC, 5 VDC LOGIC	9.50
OAC5Q	4-CHANNEL AC OUTPUT 12-280 VAC, 5 VDC LOGIC	35.00
OD10	10-FT EDGE TO HEADER CABLE	66.00
OD2	2-FT EDGE TO HEADER CABLE	39.00
OD4	4-FT EDGE TO HEADER CABLE	45.00
OD6	6-FT EDGE TO HEADER CABLE	52.00
OD8	8-FT EDGE TO HEADER CABLE	58.00
ODC15	DC OUTPUT 5-60 VDC, 15 VDC LOGIC	9.50
ODC15A	DC OUTPUT 5-200 VDC, 15 VDC LOGIC	15.40
ODC24	DC OUTPUT 5-60 VDC, 24 VDC LOGIC	9.50
ODC24A	DC OUTPUT 5-200 VDC, 24 VDC LOGIC	15.40
ODC5	DC OUTPUT 5-60 VDC, 5 VDC LOGIC	9.50
ODC5A	DC OUTPUT 5-200 VDC, 5 VDC LOGIC	15.40
ODC5AQ	4-CHANNEL DC OUTPUT 5-200 VDC, 5 VDC LOGIC	50.00
ODC5P	P MODEL DC OUTPUT 5-60 VDC, 5 VDC LOGIC	9.50
ODC5Q	4-CHANNEL DC OUTPUT 5-60 VDC, 5 VDC LOGIC	35.00
ODC5R	REED RELAY OUTPUT, 5 VDC LOGIC	10.50
ODC5RM	DC OUTPUT MODULE	18.00
OPTOCONTROL	obsolete	99.00
OPTODISPLAY	obsolete	99.00
OPTODRIVER	OPTODRIVER TOOLKIT	295.00
OPTOINFO CDB	OPTO INFO CD BULK 25 PACK	25.00
OPTOINTMB	OPTO INTEGRATION MOD BUS	425.00
OPTOSERVER	OPTOSERVER	99.00
OUTPUT SWITCH	OUTPUT SWITCH 250 VAC	15.50
P120D2	P MODEL, 120 VAC, 2 AMP, DC CONTROL	8.50
P120D4	P MODEL, 120 VAC, 4 AMP, DC CONTROL	8.75
P240D2	P MODEL, 240VAC, 2 AMP, DC CONTROL	9.15
P240D4	P MODEL, 240 VAC, 4 AMP, DC CONTROL	9.75
P240D4-17	P MODEL, AC OUTPUT, 12-140 VAC, 5VDC LOGIC	10.50
PB16A	16-CHANNEL I/O MODULE RACK	62.00
PB16AH	16-CHANNEL ANALOG MOUNTING RACK	170.00
PB16C	16-CHANNEL I/O MODULE RACK EXTRA TERMINAL STRIP	95.00
PB16H	16-CHANNEL RACK W/HEADER CONNECTOR	69.00
PB16HC	16-CHANNEL RACK W/HEADER CONNECTOR COMMON TB	98.00
PB16HQ	QUAD 4-MODULE POSITION RACK	69.00
PB16J	DC INPUT 4-16VDC 16-CHANNEL INTEGRAL	115.00
PB16K	DC INPUT 16-28VDC 16-CHANNEL INTEGRAL	115.00
PB16L	DC OUTPUT 5-60VDC 16-CHANNEL INTEGRAL	115.00
PB16T	16-CHANNEL I/O MODULE RACK	80.00
PB24	24-CHANNEL I/O MODULE RACK	97.00
PB24HQ	QUAD 6-MODULE POSITION RACK WITH HEADER CONNECTOR	115.00
PB24Q	QUAD 6-MODULE POSITION RACK	108.00
PB32DEC	QUAD 8-MODULE POSITION RACK	125.00
PB32HQ	QUAD 8-MODULE RACK W/HEADER CONNECTOR FOR B4 BRAIN	120.00
PB4	4-CHANNEL I/O MODULE RACK	21.00
PB4AH	4-CHANNEL ANALOG MOUNTING RACK	85.00
PB4H	4-CHANNEL RACK W/HEADER CONNECTOR	42.00
PB4MOA	4-CHANNEL SWITCH ASSEMBLY	64.00
PB4R	4-CHANNEL OUTPUT MODULE RACK	35.00
PB8	8-CHANNEL I/O MODULE RACK	38.00
PB8AH	8-CHANNEL ANALOG MOUNTING RACK	125.00
PB8H	8-CHANNEL RACK W/HEADER CONNECTOR	56.00
PBSA	POWER SUPPLY 120 VAC	70.00
PBSB	POWER SUPPLY 220 VAC	70.00
PBSC	POWER SUPPLY 12/24 VDC	95.00
PCI-AC28	PCI-AC28 ADAPTER CARD	315.00
PCI-AC5	PCI-AC5 ADAPTER CARD	315.00
PITM UPGRADE	UPGRADE FOR PROVE IT TO ME TOOLBOX	199.00
PROVEITTO ME	PROVE IT TO ME TOOLBOX	#####
REMOTE CABLE200	REMOTE BRICK INTERPANEL CABLE	45.00
SAFETY COVER	POWER SERIES STANDARD MODEL SSR COVER	1.00
SBTA	SINGLE BRICK TERMINAL ADAPTER	25.00
SBTA100	SINGLE BRICK TERMINATOR LOCAL	45.00
SNAP-AIARMS	0-10 AMP INPUT MODULE	195.00
SNAP-AICTD	SNAP 2-CHANNEL TEMPERATURE INPUT - AICTD	182.00
SNAP-AICTD-4	SNAP 4 CHANNEL ICTD INPUT	245.00
SNAP-AIMA	2-CHANNEL ANALOG CURRENT INPUT -20mA TO +20mA	182.00
SNAP-AIMA-4	SNAP 4 CHANNEL ANALOG CURRENT INPUT	245.00
SNAP-AIMA-i	2 CHANNEL AIMA ISOLATED	265.00
SNAP-AIMV-4	SNAP 4 CHANNEL ANALOG +/-150 mV INPUT	245.00
SNAP-AIMV2-4	SNAP 4 CHANNEL ANALOG +/-50 mV INPUT	245.00
SNAP-AIRATE	SNAP DUAL CHANNEL ANALOG RATE INPUT	195.00
SNAP-AIRTD	SNAP 2-CHANNEL TEMPERATURE INPUT - 100 OHM PT RTD	195.00
SNAP-AITM	2-CHANNEL ANALOG TYPE E, J, K THERMOCOUPLE OR -150mV TO +150mV INPUT	182.00
SNAP-AITM-2	SNAP 2-CHANNEL THERMOCOUPLE INPUT TYPES B,C,D,G,N,T,R,S	182.00
SNAP-AITM-i	2 CHANNEL AITM ISOLATED	245.00
SNAP-AITM2-i	SNAP 2 CHANNEL ISOLATED THERMOCOUPLE / mV INPUT	245.00
SNAP-AIV	2-CHANNEL ANALOG INPUT VOLTAGE -10VDC TO +10VDC	182.00

Price Listing

ITEM	DESCRIPTION	1 TO 9
SNAP-AIV-4	SNAP 4 CHANNEL ANALOG AIV	245.00
SNAP-AIV-4S	SNAP 4 CHANNEL AIV FOR SPAIN (CALIB.1.25V)	245.00
SNAP-AIV-I	2 CHANNEL AIV ISOLATED	245.00
SNAP-AIVRMS	0-250 VRMS INPUT	195.00
SNAP-AOA-23	SNAP 2-CHANNEL CURRENT LOOP OUTPUT - 4-20 MA	182.00
SNAP-AOA-28	SNAP 2-CHANNEL CURRENT LOOP OUTPUT 0-20 MA	195.00
SNAP-AOA-3	SINGLE-CHANNEL ANALOG OUTPUT CURRENT 4-20MA	150.00
SNAP-AOD-29	SNAP TPO MODULE	187.00
SNAP-AOV-25	SNAP 2-CHANNEL VOLTAGE OUTPUT - 0 TO 10 VOLTS DC	182.00
SNAP-AOV-27	SNAP 2-CHANNEL VOLTAGE OUTPUT - BIPOLAR -10 TO + 10 VOLTS DC	182.00
SNAP-AOV-5	SINGLE-CHANNEL ANALOG OUTPUT 0 TO 10VDC	150.00
SNAP-AOV-7	SINGLE-CHANNEL ANALOG OUTPUT VOLTAGE -10 TO +10VDC	95.00
SNAP-B12M	12-MODULE RACK	112.00
SNAP-B12MC	12-MODULE RACK WITH EXTRA TERMINAL BLOCK FOR FIELD WIRING	133.00
SNAP-B12MC-P	12-MODULE RACK WITH EXTRA TERMINAL BLOCK FOR FIELD WIRING, PLUGGABLE	308.00
SNAP-B16M	16-MODULE RACK	161.00
SNAP-B16MC	16-MODULE RACK WITH EXTRA TERMINAL BLOCK FOR FIELD WIRING	182.00
SNAP-B16MC-P	16-MODULE RACK WITH EXTRA TERMINAL BLOCK FOR FIELD WIRING, PLUGGABLE	420.00
SNAP-B3000-ENET	SNAP B3000 ETHERNET BRAIN	695.00
SNAP-B3000-MODBUS	SNAP ANALOG/DIGITAL BRAIN MODICON MODBUS PROTOCOL	425.00
SNAP-B4	SNAP 32-CHANNEL PAMUX PROTOCOL DIGITAL BRAIN BOARD	225.00
SNAP-B4M	SNAP 4 POSITION BRAIN RACK	77.00
SNAP-B6	HIGH SPEED SNAP ANALOG/DIGITAL BRAIN	550.00
SNAP-B8M	8-MODULE RACK	94.00
SNAP-B8MC	8-MODULE RACK WITH EXTRA TERMINAL BLOCK FOR FIELD WIRING	104.00
SNAP-B8MC-P	8-MODULE RACK WITH EXTRA TERMINAL BLOCK FOR FIELD WIRING, PLUGGABLE	217.00
SNAP-BRS	SNAP 32-CHANNEL MISTIC PROTOCOL REMOTE DIGITAL BRAIN BOARD	245.00
SNAP-BRS-HA	SNAP 32-CHANNEL MISTIC PROTOCOL REMOTE DIGITAL BRAIN BOARD WITH ARCNET (5 POS CONN VERS	265.00
SNAP-CDBBDIN	CLASSIC DIGITAL BRAIN BOARD DIN RAIL ADAPTER	20.00
SNAP-D12M	12-MODULE RACK	104.00
SNAP-D12MC	12-MODULE RACK WITH EXTRA TERMINAL BLOCK FOR FIELD WIRING	123.00
SNAP-D12MC-P	12-MODULE RACK WITH EXTRA TERMINAL BLOCK FOR FIELD WIRING, PLUGGABLE	294.00
SNAP-D4M	4-MODULE RACK	42.00
SNAP-D4MC	4-MODULE RACK WITH EXTRA TERMINAL BLOCK FOR FIELD WIRING	45.00
SNAP-D4MC-P	4-MODULE RACK WITH EXTRA TERMINAL BLOCK FOR FIELD WIRING, PLUGGABLE	104.00
SNAP-D64RS	SNAP 64 POINT DIGITAL RACK	161.00
SNAP-D6M	6-MODULE RACK	60.00
SNAP-D6MC	6-MODULE RACK WITH EXTRA TERMINAL BLOCK FOR FIELD WIRING	70.00
SNAP-D6MC-P	6-MODULE RACK WITH EXTRA TERMINAL BLOCK FOR FIELD WIRING, PLUGGABLE	160.00
SNAP-D8M	8-MODULE RACK	81.00
SNAP-D8MC	8-MODULE RACK WITH EXTRA TERMINAL BLOCK FOR FIELD WIRING	94.00
SNAP-D8MC-P	8-MODULE RACK WITH EXTRA TERMINAL BLOCK FOR FIELD WIRING, PLUGGABLE	210.00
SNAP-ENET-D64	SNAP- ETHERNET D64 BRAIN	695.00
SNAP-FIELDCONB	MODULE FIELD CONNECTOR 10-PACK	70.00
SNAP-FUSE1AB	1 AMP FUSE 25-PACK	12.50
SNAP-FUSE2AB	2 AMP FUSE 25-PACK	12.50
SNAP-FUSE4AB	4-AMP FUSE 25-PACK	12.50
SNAP-IAC5	4-CHANNEL AC INPUT 90-140 VAC, 5 VDC LOGIC	42.00
SNAP-IAC5A	4-CHANNEL AC INPUT 180-280 VAC, 5 VDC LOGIC	42.00
SNAP-IAC5AFM	4-CHANNEL AC INPUT 180-280 VAC FM	47.00
SNAP-IAC5FM	SNAP 4 CHANNEL AC INPUT FM	47.00
SNAP-IAC5MA	SNAP IAC5 MANUAL AUTO MODULE	84.00
SNAP-IDC5	4-CHANNEL DC INPUT 10-32 VDC, 5 VDC LOGIC	42.00
SNAP-IDC5-FAST-A	SNAP 4 CHANNEL HI-SPEED MODULE	46.00
SNAP-IDC5-SW	SNAP INPUT MODULE SELF-WETTING N.C.	56.00
SNAP-IDC5D	SNAP DC INPUT DATA ACQUISITION	42.00
SNAP-IDC5DFM	SNAP DC INPUT DATA ACQUISITION FM	47.00
SNAP-IDC5FAST	SNAP 4-CHANNEL HI-SPEED DC INPUT 2.5 - 16VDC, 5VDC LOGIC	46.00
SNAP-IDC5FM	SNAP 4 CHANNEL DC INPUT FM	47.00
SNAP-IDC5MA	SNAP IDC5 MANUAL AUTO MODULE	84.00
SNAP-IDC5Q	SNAP QUADRATURE MODULE	182.00
SNAP-IT-PM-ADS	SNAP IT PANEL MOUNT	#####
SNAP-IT-PM-ADS-PLUS	SNAP IT BOX WITH MODEM	#####
SNAP-IT-RM-ADS	SNAP-IT RACK MOUNT ANA / DIG / SER	#####
SNAP-IT-RM-D64	SNAP 64 POINT DIGITAL MONITOR	#####
SNAP-LABEL4B	4-MODULE LABEL HOLDER WITH LABELS 25-PACK	30.00
SNAP-LABEL6B	6-MODULE LABEL HOLDER WITH LABELS 25-PACK	30.00
SNAP-LCM4	SNAP M4 LOCAL CONTROLLER	#####
SNAP-LCSX	SNAP CONTROLLER SX,2 PORT	575.00
SNAP-LCSX-PLUS	SNAP CONTROLLER SX,4 PORT	695.00
SNAP-LEARNING CTR-US	SNAP LEARNING CENTER U.S. VERSION	#####
SNAP-MODFUSEHLDRB	DIGITAL OUTPUT FUSE HOLDER 10-PACK	7.00
SNAP-MODLATCHB	MODULE RELEASE LATCH 10-PACK	14.00
SNAP-OAC5	4-CHANNEL AC OUTPUT 12-280 VAC, 5 VDC LOGIC	42.00
SNAP-OAC5-I	SNAP AC OUTPUT MODULE ISOLATED	42.00
SNAP-OAC5-IFM	SNAP AC OUTPUT MODULE ISOLATED FM	47.00
SNAP-OAC5FM	4 CHANNEL AC OUTPUT 12-280VAC FM	47.00
SNAP-OAC5MA	SNAP OAC5 MANUAL AUTO MODULE	84.00
SNAP-ODC5-I	SNAP DC OUTPUT MODULE ISOLATED	42.00
SNAP-ODC5-IFM	SNAP DC OUTPUT MODULE ISOLATED FM	47.00
SNAP-ODC5A-I	SNAP DC OUTPUTMODULE ISOLATED	42.00
SNAP-ODC5A-IFM	SNAP DC OUTPUT MOD ISOLATED FM	47.00
SNAP-ODC5ASNK	SNAP ODC5A SINK MODULE	42.00
SNAP-ODC5MA	SNAP ODC5 MANUAL AUTO MODULE	84.00
SNAP-ODCSR	SNAP DC OUTPUT REED RELAY N.O.	45.00
SNAP-ODCSR5	SNAP DC OUTPUT REED RELAY N.C.	45.00
SNAP-ODCSR5FM	SNAP DC OUTPUT REED RELAY N.C.	50.00
SNAP-ODCSR5FM	SNAP DC OUTPUT REED RELAY FM	50.00
SNAP-ODCSSNK	4-CHANNEL DC OUTPUT 5-60 VDC, 5 VDC LOGIC SINK	42.00
SNAP-ODCSSNKFM	4 CHANNEL DC OUTPUT 5-60 LOGIC SINK FM	47.00
SNAP-ODCSSRC	4-CHANNEL DC OUTPUT 5-60 VDC, 5 VDC LOGIC SOURCE	42.00
SNAP-ODCSSRCFM	4 CHANNEL DC OUTPUT 5-60VDC FM	47.00
SNAP-PDPRS64	PROFIBUS DP REMOTE SIMPLE 64 POINT BRAIN	555.00
SNAP-PS24	SNAP POWER SUPPLY - LOOP POWER - 110 VAC TO 24 VDC	200.00
SNAP-PS5	SNAP POWER SUPPLY - SINGLE RACK - 110 VAC TO 5 VDC	200.00
SNAP-PS5-24DC	SNAP DC TO DC POWER SUPPLY	200.00
SNAP-PSDIN	SNAP POWER DIN ADAPTER	28.00
SNAP-RACKDIN	SNAP RACK DIN RAIL ADAPTER CLIP	11.25
SNAP-RACKDINB	SNAP RACK DIN RAIL ADAPTER CLIP 25-PACK	245.00
SNAP-RETN4B	4-MODULE RETENTION RAIL 25-PACK	110.00
SNAP-RETN6B	6-MODULE RETENSION RAIL 25PACK	135.00
SNAP-SCM-232	DUAL ISOLATED RS232 MODULE	245.00
SNAP-SCM-485	DUAL ISOLATED RS485 MODULE	245.00
SNAP-STRAP	SNAP MODULE STRAP	8.95
SNAP-UP1-ADS	ANALOG/DIGITAL/SERIAL/ETHERNET ULTIMATE BRAIN	995.00
SNAP-WIRESTRAP	SNAP STRAP WIRE JUMPER	5.50

Price Listing

ITEM	DESCRIPTION	1 TO 9
STRAP2	2-POSITION STRAP SINGLE RACK R0433	1.00
STRAP2Q	2-POSITION STRAP QUAD RACK R0432	1.00
STRAP4Q	4-POSITION STRAP QUAD RACK R0431	1.65
STRAP8	8-POSITION STRAP SINGLE RACK R0430	1.65
TERM 1	PAMUX BUS TERMINATION CARD	30.00
TERM 2	PAMUX BUS TERMINATION CARD SHIELDED CABLE	30.00
UCA4	GENERAL PURPOSE PAMUX INTERFACE	120.00
ULTIMATEIODOCS	PRINTED DOCUMENTATION FOR SNAP ULTIMATE I/O	99.00
Z120D10	Z MODEL, 120 VAC, 10 AMP, DC CONTROL	9.80
Z240D10	Z MODEL, 240 VAC, 10 AMP, DC CONTROL	10.00
Z240D10-17	Z MODEL, 240 VAC, 10 AMP, DC CONTROL, VDE APPROVED	11.50