

OPTO 22

DATA SHEET

Form 730-050728

BRAINS CLASSIC/MISTIC 16-CHANNEL ANALOG

page 1/10

Description

The B200 is an analog brain board used to control up to 16-channels of remote analog I/O using Opto 22's Classic analog I/O mounting racks and modules. On-board intelligence enables many distributed control features. The B200 and its digital counterpart, the B100, can be used with either an Opto 22 controller or a host computer.

The B200 communicates serially via RS-485 at communication speeds up to 115K baud using the Mistic® protocol. The B200 brain board is physically interchangeable with the traditional B2 Optomux brain boards for Opto 22 Classic I/O and is plug-compatible with Classic racks. This compatibility makes it possible for a "Classic I/O customer" using Standard analog I/O to take advantage of the increased performance of Opto 22's Mistic communications protocol. The compatibility also allows Optomux users to migrate to Opto 22's FactoryFloor® software without modifying existing field or communication wiring.

Utilizing the Mistic protocol, faster communication speed is combined with advanced I/O processing to provide unmatched performance and power at the I/O level. Time-critical functions such as temperature conversion and linearization, digital filtering, max/min tracking, and averaging can be off-loaded from your host processor to the B200's intelligent I/O processor. Distributed control functions include event/reactions, which execute high-speed, deterministic responses to sophisticated control sequences, alarm monitors, or diagnostic conditions. In addition, the B200 can generate an interrupt signal to an Opto 22 controller or host computer notifying the controller that an event has occurred.

For systems I/O customers, the B200 is the gateway to Opto 22's FactoryFloor. FactoryFloor consists of these integrated components:

- OptoControl™, a graphical, flowchart-based development environment for real-time control solutions.
- OptoDisplay™, a graphical, multimedia operator interface package.
- OptoServer™, an OPC 1.0-compliant data server that connects the controller network with the PC-based FactoryFloor network.

Opto 22's OptoDriver Toolkit™ allows you to create custom solutions utilizing the B200. The OptoDriver toolkit includes 32-bit Windows-compatible drivers, Windows 16-bit drivers, and Opto 22's classic DOS drivers. The kit also provides files, documentation, and real-world examples needed to write Microsoft Windows and DOS software applications that can access Opto 22 I/O hardware, using high-level languages such as Microsoft Visual C++™ or Microsoft Visual Basic®. The OptoDriver Toolkit provides programmers with a simple, direct connection to Opto 22's industry-standard Mistic, Optomux, or Pamux® I/O systems.

Part Number	Description
B200	16-Channel Analog Brain, Mistic Protocol

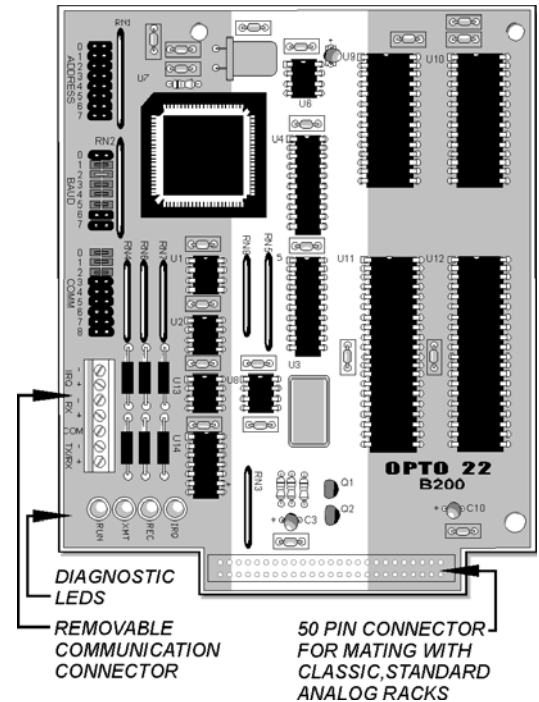

Description (Continued)

B100/B200 System Architecture

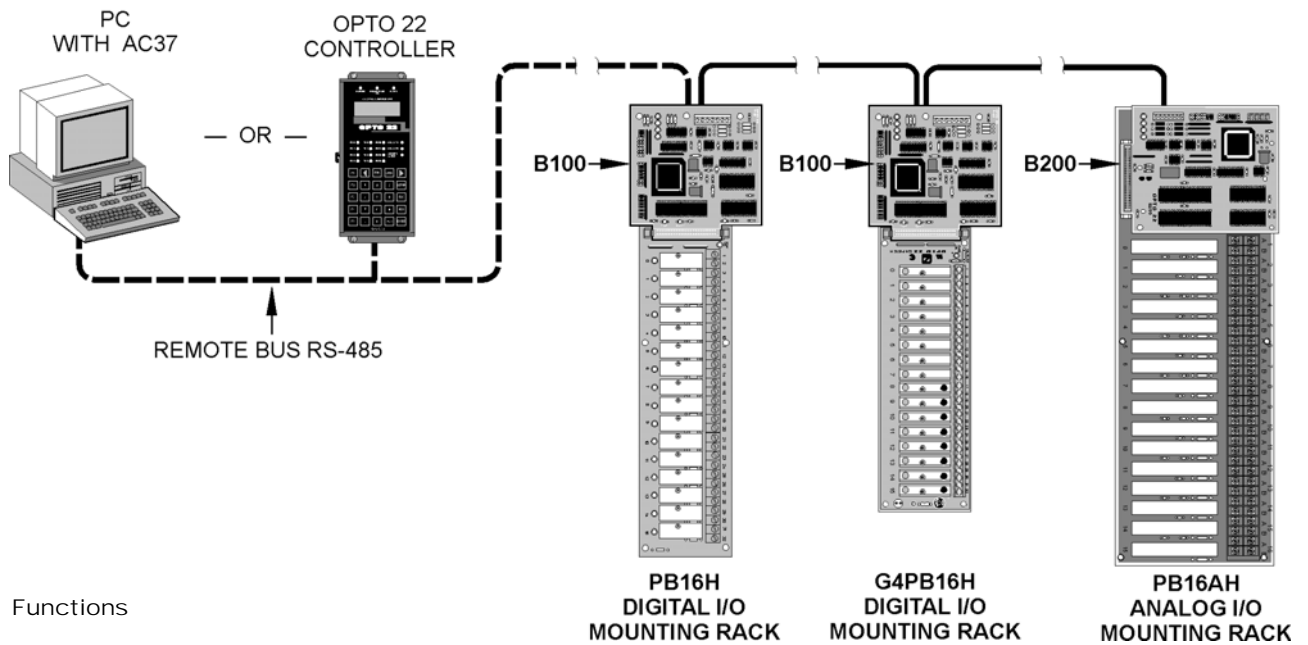

Functions

Analog
PID Loop Control
High/Low Limit Monitoring
Thermocouple Linearization
Digital Filtering
Ramping/Waveform Generation
Programmable Offset and Gain
Engineering Unit Scaling
Square Root Extraction

Specifications

MISTIC Command Set - Analog Functions

Analog Setup/System Commands

IDENTIFY TYPE
POWER-UP CLEAR
REPEAT LAST RESPONSE
RESET
RESET ALL PARAMETERS TO DEFAULT
SET COMM LINK WATCHDOG AND DELAY
SET COMM LINK WATCHDOG TIME-OUT DATA
SET RESPONSE DELAY
SET SYSTEM OPTIONS

Analog I/O Configuration Commands

CALCULATE AND SET ADC MODULE OFFSET
CALCULATE AND SET ADC MODULE GAIN
READ MODULE CONFIGURATION
SET ADC MODULE OFFSET
SET ADC MODULE GAIN
SET AVERAGING SAMPLE WEIGHT
SET CHANNEL CONFIGURATION
SET ENGINEERING UNIT SCALING PARAMETERS
SET I/O CONFIGURATION - GROUP
SET TOTALIZATION SAMPLE WEIGHT
SET TPO RESOLUTION
STORE SYSTEM CONFIGURATION

Analog Read/Write/Output Commands

RAMP DAC OUTPUT TO ENDPOINT
READ AND CLEAR I/O MODULE DATA
READ AND CLEAR I/O MODULE DATA - GROUP
READ I/O MODULE MAGNITUDE
READ I/O MODULE MAGNITUDE - GROUP
SET DAC MODULE MAGNITUDE, ENG. UNITS
SET DAC MODULE MAGNITUDE, ENG. UNITS - GROUP
SET DAC MODULE MAGNITUDE, COUNTS
SET DAC MODULE MAGNITUDE, COUNTS - GROUP

Analog Event/Reaction Commands

CLEAR EVENT/REACTION TABLE
CLEAR EVENT TABLE ENTRY
CLEAR INTERRUPT
ENABLE/DISABLE EVENT ENTRY - GROUP
ENABLE/DISABLE EVENT TABLE ENTRY
READ AND CLEAR EVENT LATCHES
READ EVENT DATA HOLDING BUFFER
READ EVENT ENTRY ENABLE/DISABLE STATUS
READ EVENT LATCHES
READ AND OPTIONALLY CLEAR EVENT LATCH
READ EVENT TABLE ENTRY
SET EVENT INTERRUPT STATUS
SET EVENT ON COMM LINK WATCHDOG TIME-OUT
SET EVENT ON I/O \geq SETPOINT
SET EVENT ON I/O \leq SETPOINT
SET EVENT REACTION COMMAND

Analog PID Loop Commands

INITIALIZE PID LOOP
READ ALL PID LOOP PARAMETERS
READ PID LOOP PARAMETER
SET PID LOOP CONTROL OPTIONS
SET PID LOOP DERIVATIVE RATE
SET PID LOOP GAIN
SET PID LOOP INTEGRAL RESET RATE
SET PID LOOP MIN-MAX OUTPUT LIMITS
SET PID LOOP MIN-MAX SETPOINT LIMITS
SET PID LOOP PROCESS VARIABLE
SET PID LOOP SETPOINT

1. For detailed information about Mistic Command Set, refer to Mistic Protocol User's Guide (Form #270) or Misticware™ User's Guide (Form #522).
2. For detailed information about Optomux Command Set, refer to Optomux Protocol Guide (Form #1572).

Form 730-050728

Specifications

General

Operating Specifications

Power Requirements	5.0 VDC \pm 0.1 VDC @ 600 mA max. (supplied through header connector pins 1 and 49).
Operating Temperature	0° to 70°C, 95% humidity, non-condensing
CPU	16-bit Intel 80C196 I/O processor
Communications Interface	RS-485 twisted pair with shield, 2-wire or 4-wire (if using interrupts)
Data Rates	300, 600, 1200, 2400, 4800, 9600, 19200, 38400, 57600, 76800, and 115200 baud
Range: Multidrop	Unlimited. (Up to 3,000 feet or 32 stations maximum between repeaters)
PID Update Rate	100 ms (for 1 to 8 PID loops)
LED Indicators	RUN (Power On), RCV (Receive), XMT (Transmit), and (IRQ) Interrupt
Options: Jumper Selectable	Address, communication, baud rate, CRC/Checksum, Binary/ASCII

Connectors and Jumpers

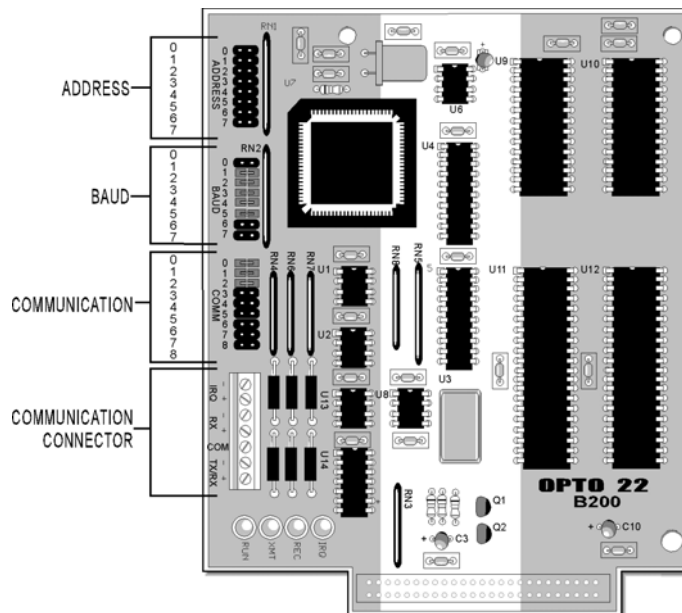

Form 730-050728

Specifications

LED Descriptions Communication Jumpers/Wiring

Communication Jumper Descriptions

Jumper	Description
0	Pull-up for TX/RX+
1	Terminator for TX/RX lines
2	Pull-down for TX/RX-
3	Pull-up for RX+
4	Terminator for RX lines
5	Pull-down for RX-
6	Pull-up for IRQ+
7	Terminator for IRQ lines
8	Pull-down for IRQ-

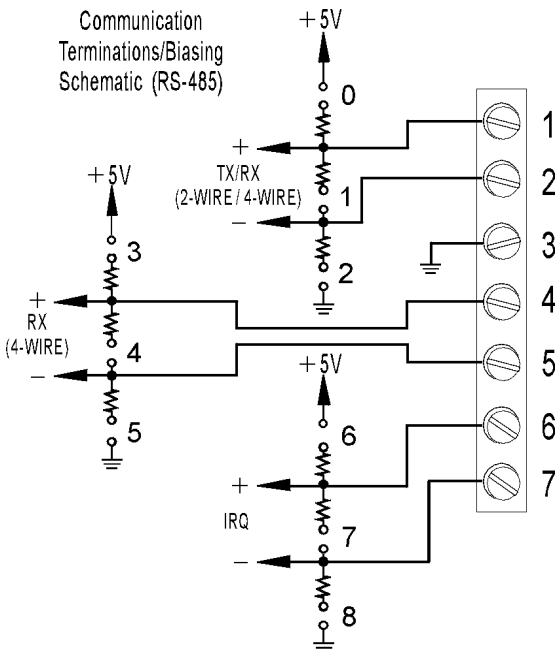
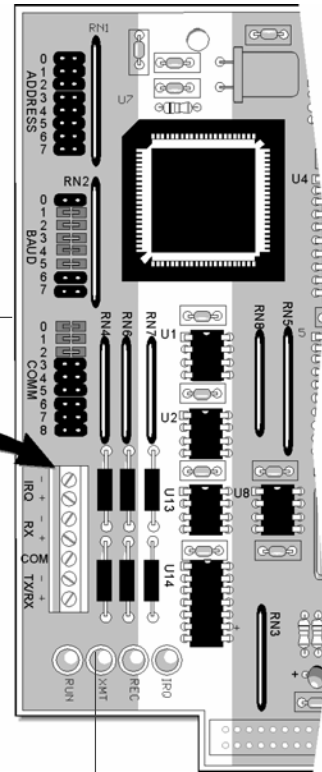
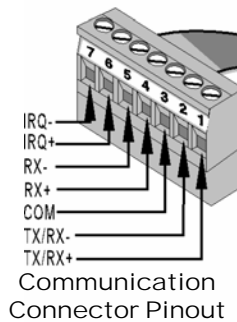

LED Description Table

LED	Description
IRQ	Processor interrupt request currently active.
RCV	Processor is currently receiving data on communication line.
XMT	Processor is currently transmitting data on communication line.
RUN	Power on Processor

Form 730-050728

Specifications

Communication Jumpers/Wiring (Continued)

Standard 2-Wire Configuration

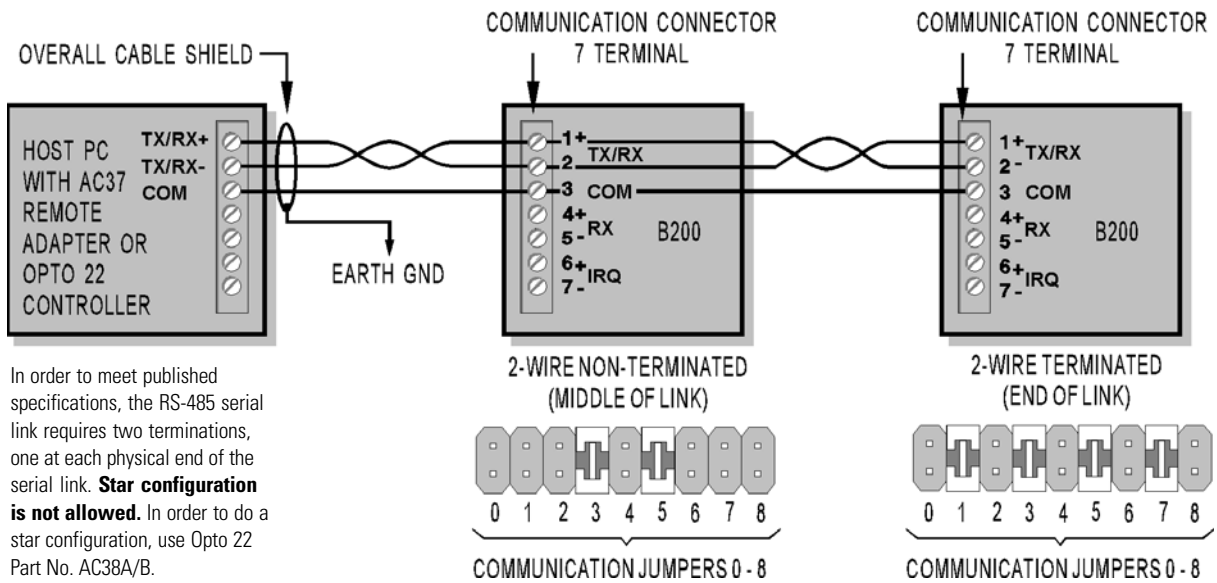

Alternate 4-Wire Configuration

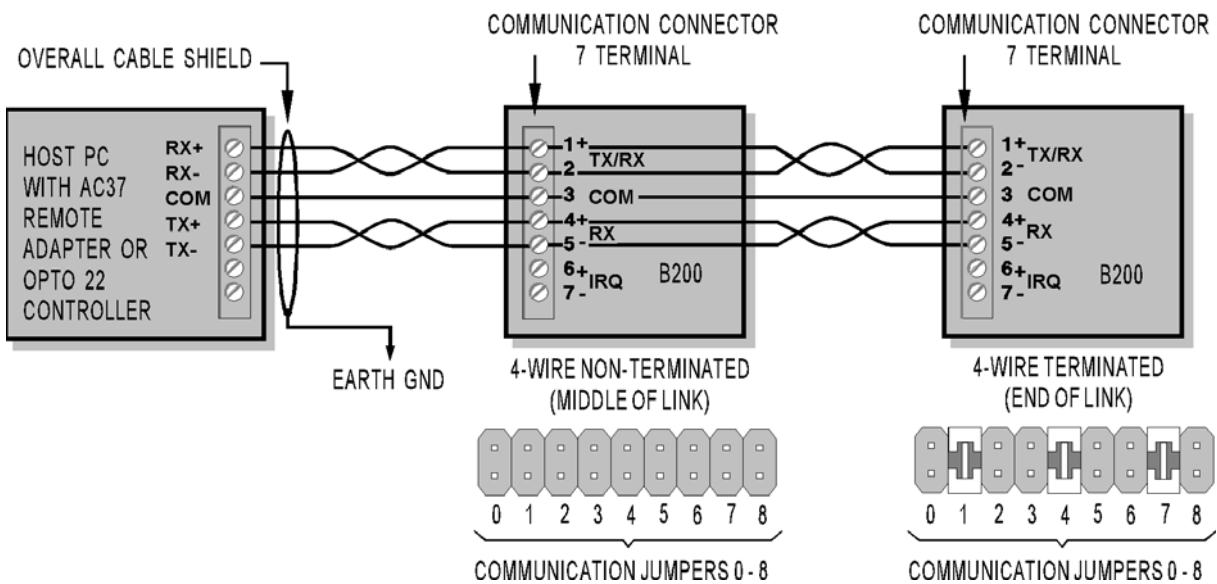

Form 730-050728

Specifications

Baud/Address Jumpers, LED Descriptions

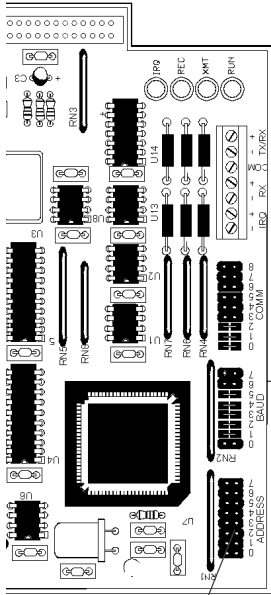

Table 1: Baud Rate Jumpers (0 - 3)

Baud Rate	Jumper Position 0	Jumper Position 1	Jumper Position 2	Jumper Position 3
115.2 KBaud (factory default setting)	Out	In	In	In
76.8 KBaud	In	Out	In	In
57.6 KBaud	Out	Out	In	In
38.4 KBaud	In	In	Out	In
19.2 KBaud	Out	In	Out	In
9600 Baud	In	Out	Out	In
4800 Baud	Out	Out	Out	In
2400 Baud	In	In	In	Out
1200 Baud	Out	In	In	Out
600 Baud	In	Out	In	Out
300 Baud	Out	Out	In	Out

Baud 0 - 3:

Use Table 1 to select appropriate baud rate.

Baud 4: (Mistic mode select jumper):

When using Mistic protocol; used to select either binary mode (jumper in, factory default setting) or ASCII mode (jumper out).

Baud 5: (Data verification jumper):

Used to select whether the type of data verification method used is Checksum Modulo 256 (jumper out) or CRC16 (jumper in, factory default setting).

Baud 6, 7:

Unused.

Address Jumpers (ADDRESS 0-7)

Use these jumpers to select an 8-bit address from 0 to 255 (0 to FF hexadecimal). The factory default is 0 (all jumpers out). The most significant bit is 7 and the least significant bit is 0.

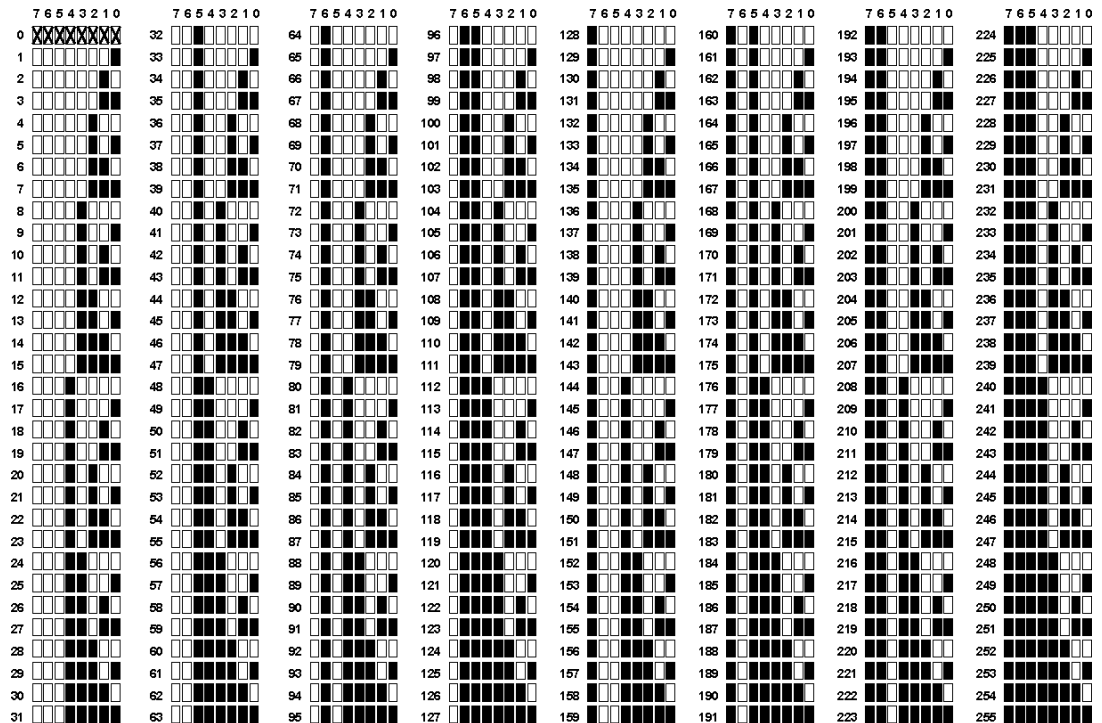

■ = JUMPER INSTALLED □ = NO JUMPER

OPTO 22

DATA SHEET

Form 730-050728

BRAINS CLASSIC/MISTIC 16-CHANNEL ANALOG

page 8/10

Dimensional Drawing

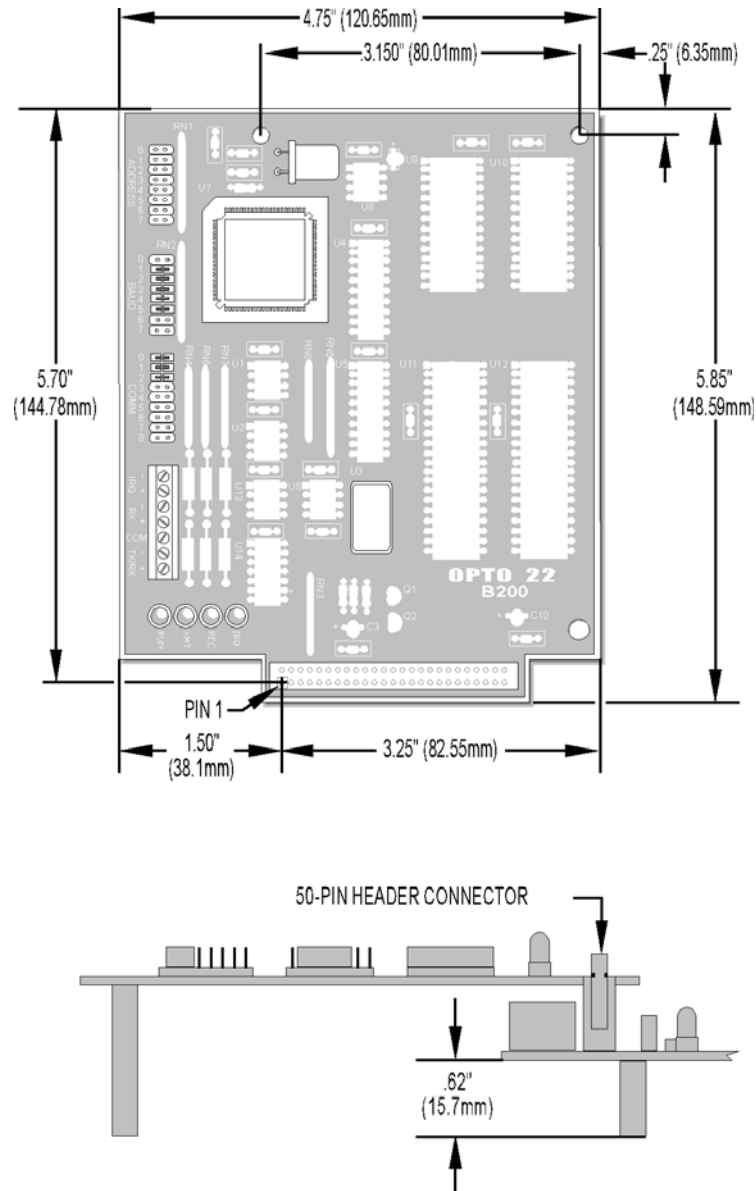

Form 730-050728

Assembly

Mounting the B200

Installing a B200 onto a Mounting Rack

1. Align the brain board's header connector with the mounting rack's header connector.
2. Firmly press the header connectors together until the locking tabs clamp down on the brain board as shown in the diagram below.

Installing a B200 onto a Mounting Rack

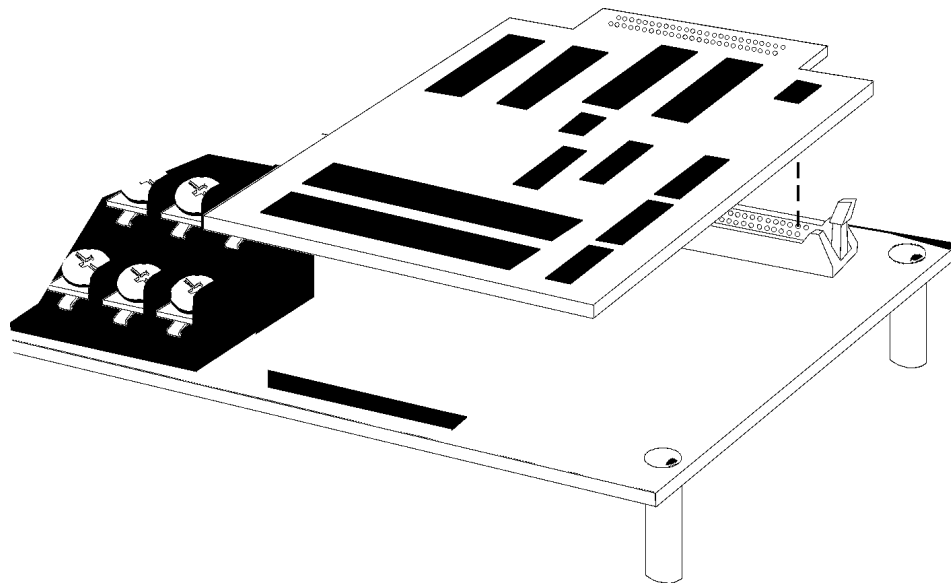

Products

Opto 22 produces a broad array of reliable, flexible hardware and software products for industrial automation, remote monitoring, enterprise data acquisition, and machine-to-machine (M2M) applications.

SNAP Ethernet Systems

Based on the Internet Protocol (IP), SNAP Ethernet systems offer flexibility in their network connectivity and in the software applications they work with. The physical network may be a wired Ethernet network, a cellular wireless network, or a modem. A wide variety of software applications can exchange data with SNAP Ethernet systems, including:

- Opto 22's own ioProject™ suite of control and HMI software
- Manufacturing resource planning (MRP), enterprise management, and other enterprise systems
- Human-machine interfaces (HMIs)
- Databases
- Email systems
- OPC client software
- Custom applications
- Modbus/TCP software and hardware.



SNAP Ethernet system hardware consists of controllers and I/O units. Controllers provide central control and data distribution. I/O units provide local connection to sensors and equipment.

SNAP OEM Systems

Opto 22 SNAP OEM I/O systems are highly configurable, programmable processors intended for OEMs, IT professionals, and others who need to use custom software with Opto 22 SNAP I/O modules.

Linux® applications running on these systems can read and write to analog, simple digital, and serial I/O points on SNAP I/O modules using easily implemented file-based operations. Applications can be developed using several common development tools and environments, including C or C++, Java, and shell scripts.



M2M Systems

Machine-to-machine (M2M) systems connect your business computer systems to the machines, devices, and environments you want to monitor, control, or collect data from. M2M systems often use wireless cellular communications to link remote facilities to central systems over the Internet, or to provide monitoring and control capability via a cellular phone.

Opto 22's Nvio™ systems include everything you need for M2M—interface and communications hardware, data service plan, and Web portal—in one easy-to-use package. Visit nvio.opto22.com for more information.

Opto 22 Software

Opto 22's ioProject and FactoryFloor® software suites provide full-featured and cost-effective control, HMI, and OPC software to power your Opto 22 hardware. These software applications help you develop control automation solutions, build easy-to-use operator interfaces, and expand your manufacturing systems' connectivity.



Quality

In delivering hardware and software solutions for worldwide device management and control, Opto 22 retains the highest commitment to quality. We do no statistical testing; each product is made in the U.S.A. and is tested twice before leaving our 160,000 square-foot manufacturing facility in Temecula, California. That's why we can guarantee solid-state relays and optically-isolated I/O modules *for life*.

Product Support

Opto 22's Product Support Group offers comprehensive technical support for Opto 22 products. The staff of support engineers represents years of training and experience, and can assist with a variety of project implementation questions. Product support is available in English and Spanish from Monday through Friday, 7 a.m. to 5 p.m. PST.

Opto 22 Web Sites

- www.opto22.com
- nvio.opto22.com
- www.internetio.com (live Internet I/O demo)

Other Resources

- OptoInfo CDs
- Custom integration and development
- Hands-on customer training classes.



About Opto 22

Opto 22 manufactures and develops hardware and software products for industrial automation, remote monitoring, enterprise data acquisition, and machine-to-machine (M2M) applications. Using standard, commercially available Internet, networking, and computer technologies, Opto 22's input/output and control systems allow customers to monitor, control, and acquire data from all of the mechanical, electrical, and electronic assets that are key to their business operations. Opto 22's products and services support automation end users, OEMs, and information technology and operations personnel.

Founded in 1974 and with over 85 million Opto 22-connected devices deployed worldwide, the company has an established reputation for quality and reliability.