



sinamics



 SINAMICS G110
Inverter Chassis Units
0.12 kW to 3 kW

SIEMENS

Related Catalogs

SINAMICS G150

Drive Converter Cabinet Units
75 kW to 800 kW
Order No.:
German: E86060-K5511-A101-A2
English: E86060-K5511-A101-A2-7600

D 11

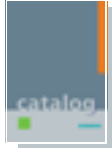

MICROMASTER

MICROMASTER 410/420/430/440
Inverters
0.12 kW to 250 kW
Order No.:
German: E86060-K5151-A121-A4
English: E86060-K5151-A121-A4-7600

DA 51.2

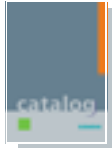

MICROMASTER/COMBIMASTER

MICROMASTER 411 Inverters
Distributed Drive Solutions
COMBIMASTER 411
Order No.:
German: E86060-K5251-A131-A2
English: E86060-K5251-A131-A2-7600

DA 51.3

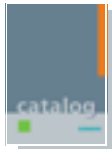

SIVOLT A/V

Alternating current and three-
phase current controller
Order No.:
German: E20002-K4068-A101-A1

DA 68

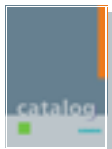

Low-Voltage Motors

Order No.:
German: E86060-K1711-A101-A3
English: E86060-K1711-A101-A3-7600

M 11

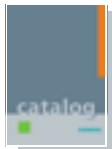

Components for automation

Order No.:
German: E86060-D4001-A100-C1
English: E86060-D4001-A110-C1-7600

CA 01



A&D Mail

Internet
<http://www.siemens.com/automation/maill>



Catalog CA 01 – SD configurator selection aid

In future the **SD configurator** selection aid will be available in combination with the CA 01 electronic catalog and no longer on a separate CD.



On CD 2 of the selection and configuration aids you will find the SD configurator for low-voltage motors, inverters MICROMASTER 4 and SINAMICS G110 including:

- Dimension drawing generator for motors
- Data sheet generator for motors
- Starting calculation
- 3D models in .stp format
- Extensive documentation

Hardware and software requirements

- PC with Pentium II or comparable processor
- Operating systems
 - Windows 98/ME
 - Windows 2000
 - Windows XP
 - Windows NT (Service Pack 5 upwards)
- Minimum of 128 RAM
- 1024 x 768 graphics with more than 256 colors / small fonts
- CD-ROM drive
- Windows-compatible sound card
- Windows-compatible mouse

Installation

You can install this catalog directly from the CD-ROM as a complete or partial version on your hard disk or in the network.

Hotline:

For technical advice and hotline support concerning our CA 01 catalog:

Tel.: +49 (0) 180 50 50 22 2

E-Mail: adsupport@siemens.com

Trademarks

All designations in this catalog marked with ® are registered trademarks of Siemens AG.

Other names in this catalog may be trademarks which, if used by third parties for their own purposes, may violate the rights of the trademark owner.

SINAMICS G110 Inverter Chassis Units

Catalog D 11.1
December 2003



The products in this catalog are also included in the CD-ROM catalog CA 01.
Order No.:
E86060-D4001-A110-C1-7600

Contact your local Siemens representative for further information

© Siemens AG 2003



The products and systems described in this catalog are manufactured/sold under application of a certified quality management system in accordance with DIN EN ISO 9001. The certificate is recognized in all IQNet countries.



SIEMENS

Introduction	Welcome to Automation and Drives	Page 2
Frequency inverters	Overview Benefits Application Design Function Technical data Selection and ordering data Dimensional drawings Schematic	3
Variant dependent options	Overview Selection and ordering data	11
Variant independent options and Documentation	Overview Selection and ordering data	13
Training	Overview Training case Starter kit	14
Appendix	A&D in the WWW Easy shopping with the A&D Mall Service & Support Conditions of sale and delivery Export regulations	16

Welcome to Automation and Drives

We would like to welcome you to Automation and Drives and our comprehensive range of products, systems, solutions and services for production and process automation and building technology worldwide.

With integrated automation blocks, powerful engineering tools and innovative concepts such as Totally Integrated Automation and Totally Integrated Power, we deliver solution platforms based on standards that offer you a considerable savings potential.

Discover the world of our technology now. If you need more detailed information, please contact one of your regional Siemens partners.

They will be glad to assist you.



Overview



SINAMICS G110, frame size A (on the right with flat plate heatsink)



SINAMICS G110, frame sizes B and C

SINAMICS G110 is a frequency inverter with basic functions for a variety of industrial variable-speed drive applications.

The particularly compact SINAMICS G110 inverter operates with voltage frequency control on single-phase supplies (200 V to 240 V).

It is the ideal low-cost frequency inverter solution for the lower power range of the SINAMICS family.

The latest technical documentation (catalogs, dimensional drawings, certificates, user manuals and operating instructions) is available on the Internet at:

<http://www.siemens.com/sinamics-g110>

and also on CD-ROM CA 01 Vol. 2 "Planning" in the SD configurator, which can be ordered from the following address:

<http://www.siemens.com/automation/CA01>

Benefits

- Easy to install, parameterize and commission
- Rugged EMC design
- Comprehensive range of parameters enabling configuration for a wide range of applications
- Simple cable connection
- Scaleable functionality due to analog and USS variants
- High pulse frequencies for low-noise motor operation
- Status information and alarm messages with the optional Basic Operator Panel (BOP)
- Time saving parameter cloning with the optional Basic Operator Panel (BOP)
- External options for PC communications and Basic Operator Panel (BOP)
- Fast, repeatable digital input response time for fast reaction applications

Benefits (continued)

- Precise setpoint entry by means of a high resolution 10-bit analog input (analog variants only)
- LED for status information
- Versions with internal EMC filters Class A or B
- DIP switch for easy setting of 50 Hz or 60 Hz applications
- DIP switch for easy bus termination on the RS485 USS variant
- RS485 serial interface (USS variants only) facilitates connection to a networked drive system.

Options (overview)

- Low leakage EMC Class B filter
- Supplementary EMC Class B filter
- Line reactors
- Basic Operator Panel (BOP)
- DIN rail mounting kit (frame sizes A and B)
- PC to inverter connection kit
- STARTER commissioning tool.

International standards

- Complies with the requirements of the EC low voltage directive
- CE marking
- UL and cUL listed
- c-tick.

Application

SINAMICS G110 is especially suited for use with pumps and fans, or as a drive in various industrial sectors, such as the food, textile and packaging industries, as well as for conveyor systems, factory gate and garage door operating mechanisms, and as a universal drive for moving billboards.

Design

The chassis units of the SINAMICS G110 family comprise the control unit and CPM 110 power module giving the inverters a compact and efficient design. The inverters use latest IGBT technology and digital microprocessor control.

The SINAMICS G110 inverter family consists of the following variants and versions:

- **Analog variant** available in the following versions:
 - without EMC filter, with heatsink
 - integrated EMC Class A/B filter, with heatsink
 - without EMC filter, with flat plate heatsink (FS A only)
 - integrated EMC Class B filter, with flat plate heatsink (FS A only).
- **USS variant** (RS485) available in the following versions:
 - without EMC filter, with heatsink
 - integrated EMC Class A/B filter, with heatsink
 - without EMC filter, with flat plate heatsink (FS A only)
 - integrated EMC Class B filter, with flat plate heatsink (FS A only).

Cooling is achieved on FS A by a heatsink and natural convection. The FS A flat plate heatsink version offers space saving and favorable heat dissipation because an additional heatsink can be installed outside the control cabinet. On FS B and FS C an integrated fan is used to cool the heatsink, which ensures the design is as compact as possible.

SINAMICS G110

Chassis units

Frequency inverters

Design (continued)

The connections on all versions of the inverter are easily accessible and conform to the standard layout. The mains and motor connections are separated for optimum electromagnetic compatibility and clear connection (as with contactors). The control terminal strip has a screwless design.

The optional Basic Operator Panel BOP can be fitted without the need for tools.

Function

- Careful handling of the machine mechanical system due to a skip frequency band in case of resonance, parameterizable ramp up/ramp down times up to 650 s, ramp smoothing, as well as bringing the inverter into circuit on turning motor (flying start)
- Increased installation availability by automatic restart facility following power failure or fault
- Fast current limit (FCL) for trip-free operation in case of sudden load changes
- Programmable V/f characteristic (e.g. for synchronous motors)
- Fast DC braking without external braking resistor
- Limitation of DC link voltage by means of the V_{DCmax} controller
- Slip compensation, electronic motor potentiometer function and three fixed speed setpoints
- Configurable voltage boost for higher dynamic response when starting and accelerating
- Motor holding brake function to control an external mechanical brake.

Technical data

Power range	0.12 kW to 3.0 kW	
Supply voltage	1 AC 200 V to 240 V $\pm 10\%$	
Power frequency	47 Hz to 63 Hz	
Output frequency	0 Hz to 650 Hz	
cos phi	≥ 0.95	
Inverter efficiency	Inverters < 0.75 kW: 90% to 94% Inverters ≥ 0.75 kW: $\geq 95\%$	
Overload capability	Overload current 1.5 x rated output current (i.e. 150% overload capability) for 60 s, then 0.85 x rated output current for 240 s, cycle time 300 s	
Inrush current	less than rated input current	
Control method	linear V/f characteristic (with programmable voltage boost); quadratic V/f characteristic; multipoint characteristic (programmable V/f characteristic)	
Pulse frequency	8 kHz (standard) 2 kHz to 16 kHz (in 2 kHz steps)	
Fixed frequencies	3, programmable	
Skip frequency band	1, programmable	
Setpoint resolution	0.01 Hz digital 0.01 Hz serial 10 bit analog (motor potentiometer 0.1 Hz)	
Digital inputs	3 programmable digital inputs, non-isolated; PNP type, SIMATIC compatible	
Analog input (analog variant)	1, for setpoint (0 V to 10 V, scaleable or for use as 4th digital input)	
Digital output	1 isolated optocoupler output (24 V DC, 50 mA, resistive, NPN type)	
Serial interface (USS variant)	RS485, for operation with USS protocol	
Motor cable length	max. 25 m (shielded) max. 50 m (unshielded)	
Electromagnetic compatibility	all devices with internal EMC filter for power drive systems in category C2 installations (restricted availability), limit complies with EN 55 011, Class A, Group 1	furthermore, all filtered devices with shielded cables with a max. length of 5 m comply with the limits of EN 55 011, Class B
Braking	DC braking	
Protection level	IP20	
Temperature range	-10 °C to +40 °C up to +50 °C with derating	
Storage temperature	-40 °C to +70 °C	

Technical data (continued)

Humidity	95% (non-condensing)		
Operational altitudes	up to 1000 m above sea level without derating Rated output current at 4000 m above sea level: 90% Supply voltage up to 2000 m above sea level: 100% at 4000 m above sea level: 75%		
Protection features for	undervoltage, overvoltage, earth faults, short circuits, stall prevention, I^2t thermal motor protection, inverter over-temperature, motor over-temperature		
Conformity with standards	UL, cUL, CE, c-tick		
CE marking	conformity with EC low voltage directive 73/23/EEC		
Dimensions and weights (without options)	Frame size	Dimensions H x W x D	Weight, approx. (kg)
	(FS)	mm	unfiltered filtered
	A ≤ 0.37 kW	150 x 90 x 116	0.7 0.8
	A 0.55 kW and 0.75 kW	150 x 90 x 131	0.8 0.9
	A ≤ 0.37 kW with flat plate heatsink	150 x 90 x 101	0.6 0.7
	A 0.55 kW and 0.75 kW with flat plate heatsink	150 x 90 x 101	0.7 0.8
	B	160 x 140 x 142	1.4 1.5
	C 2.2 kW	181 x 184 x 152	1.9 2.1
C 3.0 kW	181 x 184 x 152	2.0 2.2	

Technical data for versions with flat plate heatsink

The flat plate heatsink version offers space saving and favorable heat dissipation because an additional heatsink can be installed outside the control cabinet.

Output	120 W	250 W	370 W	550 W	750 W
Operating temperature	-10 °C to +50 °C	-10 °C to +50 °C	-10 °C to +50 °C	-10 °C to +50 °C	-10 °C to +40 °C
Total losses at full load and maximum operating temperature as specified	22 W	28 W	36 W	43 W	54 W
Line-side and control losses	9 W	10 W	12 W	13 W	15 W
Recommended thermal resistance of heatsink	3.0 K/W	2.2 K/W	1.6 K/W	1.2 K/W	1.2 K/W
Recommended output current	0.9 A	1.7 A	2.3 A	3.2 A	3.9 A

Derating data

Pulse frequency

Output kW	Rated output current in A for a pulse frequency of							
	2 kHz	4 kHz	6 kHz	8 kHz	10 kHz	12 kHz	14 kHz	16 kHz
0.12	0.9	0.9	0.9	0.9	0.9	0.9	0.9	0.9
0.25	1.7	1.7	1.7	1.7	1.7	1.7	1.7	1.7
0.37	2.3	2.3	2.3	2.3	2.3	2.3	2.3	2.3
0.55	3.2	3.2	3.2	3.2	3.0	2.7	2.5	2.2
0.75 (at 40 °C)	3.9	3.9	3.9	3.9	3.6	3.3	3.0	2.7
0.75	3.2	3.2	3.2	3.2	3.0	2.7	2.5	2.2
1.1	6.0	6.0	6.0	6.0	5.9	5.7	5.6	5.4
1.5 (at 40 °C)	7.8	7.8	7.8	7.8	7.6	7.4	7.2	7.0
1.5	6.0	6.0	6.0	6.0	5.9	5.7	5.6	5.4
2.2	11.0	11.0	11.0	11.0	10.8	10.5	10.2	9.9
3.0 (at 40 °C)	13.6	13.6	13.6	13.6	13.3	12.9	12.6	12.3
3.0	11.0	11.0	11.0	11.0	10.8	10.5	10.2	9.9

The current data applies for an ambient temperature of 50 °C unless otherwise specified.

Technical data (continued)

Standard conversion factors: metric to US units

Unit	US to metric standard units	Metric to US standard units
Length	1 in. = 25.40 mm 1 ft. = 30.48 cm 1 yd = 0.91 m 1 mi. = 1.61 km	1 mm = 0.03937 in. 1 cm = 0.39370 in. 1 m = 3.28084 ft. 1 km = 0.62137 mi.
Temperature	°C = 5/9 (°F - 32)	°F = (9 x °C)/5 + 32
Weight	1lbs = 0.454 kg	1 kg = 2.205 lbs
Torque	1lb.ft. = 1.356 Nm	1 Nm = 0.738 lb.ft.
Power	1 hp = 0.746 kW	1 kW = 1.341 hp

Note:

For kW and hp specifications in the Selection and Ordering tables, we do not use calculated hp values but the corresponding standardized hp motor ratings.

Conformity with standards

CE marking



The SINAMICS G110 inverters comply with the requirements of the low voltage directive 73/23/EEC. A certificate of conformity can be issued on request.

Low voltage directive

The inverters comply with the following standards listed in the official EU journal:

- EN 60 204
Safety of machinery, electrical equipment of machines
- EN 50 178
Electronic equipment in electrical power installations.

Machinery directive

The inverters are suitable for installation in machines. Compliance with the machinery directive 89/392/EEC requires a separate certificate of conformity. This must be issued by the firm which constructs the plant or puts the machine on the market.

EMC directive

- EN 61 800-3
Variable speed electrical power drive systems
Part 3: EMC product standard including specific test methods.

The modified EMC product standard EN 61 800-3/A11 for electrical power drive systems came into effect on 01.01.2002. The following comments apply to the SINAMICS G110 frequency inverters from Siemens:

- The EMC product standard EN 61 800-3/A11 does not apply directly to a frequency inverter but to a PDS (Power Drive System), which comprises the complete circuitry, motor and cables in addition to the inverter.
- A frequency inverter must therefore only be considered as a component which, on its own, is not subject to the EMC product standard EN 61 800-3/A11. However, the inverter Operating Manual specifies the conditions under which the product standard can be met if the frequency inverter is used within a PDS. The EMC directive in the EU is met for a PDS by observing the product standard EN 61 800-3/A11 for PDS. The frequency inverters on their own do not generally require marking according to the EMC directive.

- As components on their own, the frequency inverters are only classified as "restricted availability" for persons and users with the necessary EMC knowledge. They are not designed for unrestricted sale or "general availability" for users.

At this point a clear distinction must be made between the frequency inverter and the PDS. A PDS can certainly be designed by the machine manufacturer for general availability, and the standard must be applied accordingly. However, the components used in the PDS may not necessarily be designed for "general availability".

- Since 01.01.2002, the EMC product standard EN 61 800-3/A11 also defines, for the first time, limits for conducted interference and radiated interference for the so-called "second environment" (= industrial power supply systems which do not supply households). Although these limits lie below those of filter Class A according to EN 55 011, a PDS with an unfiltered frequency inverter from the SINAMICS G110 series does not comply with these values, and therefore does not meet the standard EN 61 800-3/A11. However, the use of unfiltered inverters in an industrial installation is possible, if it forms part of a system which includes power-line filtering at the "system level".
- Using internal or external filters and the installation instructions included in the documentation, the PDS designed using the frequency inverters complies with the product standard EN 61 800-3/A11:
 - with Class B low leakage filters to EN 55 011 in the first environment (residential, commercial and light industry), unrestricted sale
 - with Class A filters to EN 55 011 in the first environment plus warning label, restricted sale and installation by EMC experts
 - with Class B filters to EN 55 011 in the first environment, restricted sale
 - with Class A filters to EN 55 011 in the second environment (industrial areas), where these filters even significantly exceed the requirements of EN 61 800-3/A11.
- A distinction must be made between the product standards for electrical power drive systems (PDS), i.e. the range of standards EN 61 800-3/A11 (of which Part 3/A11 covers EMC) and the product standards for the devices/systems/machines etc. There should be no changes in the practical use of frequency inverters. Since frequency inverters are always part of a PDS, and these are part of a machine, the machine manufacturer must observe various standards according to the machine type and environment, e.g. EN 61 000-3-2 for power supply harmonics and EN 55 011 for radio interference. The product standard for PDS on its own is therefore either insufficient or irrelevant in this context.

In terms of compliance with limits for harmonic current emissions, the EMC product standard EN 61 800-3/A11 for PDS refers to compliance with the EN 61 000-3-2 and EN 61 000-3-12 standards.

Technical data (continued)

Electromagnetic compatibility

No inadmissible electromagnetic emissions occur if the product-specific installation guidelines are correctly observed.

The table below lists the measured results for emissions and immunity to interference for SINAMICS G110 inverters.

The inverters were installed according to the guidelines with shielded motor cables and shielded control cables.

EMC phenomenon Standard/test		Relevant criteria	Limit value
Emissions EN 61 800-3 (1st environment ¹⁾)	Conducted via mains cable	150 kHz to 30 MHz	Unfiltered: not tested
	Emitted by the drive	30 MHz to 1 GHz	All devices with internal EMC filter for power drive systems in category C2 installations (restricted availability ²⁾). Limit complies with EN 55 011, Class A, Group 1. Furthermore, all filtered devices with shielded cables with a max. length of 5 m comply with the limits of EN 55 011, Class B
ESD immunity test EN 61 000-4-2	ESD through air discharge	Test level 3	8 kV
	ESD through contact discharge	Test level 3	6 kV
Electromagnetic fields immunity test EN 61 000-4-3	Electrical field applied to unit	Test level 3 26 MHz to 1 GHz	10 V/m
Burst immunity test EN 61 000-4-4	Applied to all cable terminations	Test level 4	4 kV
Surge immunity test EN 61 000-4-5	Applied to mains cables	Test level 3	2 kV
Immunity to conducted disturbances, induced by radio frequency fields EN 61 000-4-6	Applied to mains, motor and control cables	Test level 4 0.15 MHz to 80 MHz 80% AM (1 kHz)	10 V

UL listing

UL and cUL listed power conversion equipment type 5B33 in accordance with UL508C.

For use in environments with pollution degree 2.

1) 1st environment

Residential, commercial and light industry: Environment which includes residential areas as well as equipment which is directly connected to a low-voltage supply without intermediate transformer, which is used to supply residential buildings.

2) Restricted availability:

Sales channel for which the marketing/sale of the equipment is limited to distributors, customers or users who – either individually or together – have technical EMC knowledge.

Category C2:

Power Drive System (PDS) with rated voltage <1000 V.
When used in 1st environment, installation and start-up only by EMC experts.

SINAMICS G110

Chassis units

Frequency inverters

Selection and Ordering Data

Output kW	Rated input current ¹⁾		Rated output current A	Frame size	Version	SINAMICS G110 without filter Generally suited to heavy industrial applications. For details please refer to technical data "conformity with standards", "EMC directive". Order no.	SINAMICS G110 with internal filter Order no.	Filter class when using shielded cables with a cable length of max.		
	hp	A						5 m	10 m	25 m
0.12	0.16	2.3	0.9	FS A	Analog	6SL3211-0AB11-2UA0	6SL3211-0AB11-2BA0	B	A ²⁾	²⁾
						6SL3211-0AB11-2UB0	6SL3211-0AB11-2BB0	B	A ²⁾	²⁾
						6SL3211-0KB11-2UA0 (with flat plate heatsink)	6SL3211-0KB11-2BA0	B	A ²⁾	²⁾
						6SL3211-0KB11-2UB0 (with flat plate heatsink)	6SL3211-0KB11-2BB0	B	A ²⁾	²⁾
0.25	0.33	4.5	1.7	FS A	Analog	6SL3211-0AB12-5UA0	6SL3211-0AB12-5BA0	B	A ²⁾	²⁾
						6SL3211-0AB12-5UB0	6SL3211-0AB12-5BB0	B	A ²⁾	²⁾
						6SL3211-0KB12-5UA0 (with flat plate heatsink)	6SL3211-0KB12-5BA0	B	A ²⁾	²⁾
						6SL3211-0KB12-5UB0 (with flat plate heatsink)	6SL3211-0KB12-5BB0	B	A ²⁾	²⁾
0.37	0.5	6.2	2.3	FS A	Analog	6SL3211-0AB13-7UA0	6SL3211-0AB13-7BA0	B	A ²⁾	²⁾
						6SL3211-0AB13-7UB0	6SL3211-0AB13-7BB0	B	A ²⁾	²⁾
						6SL3211-0KB13-7UA0 (with flat plate heatsink)	6SL3211-0KB13-7BA0	B	A ²⁾	²⁾
						6SL3211-0KB13-7UB0 (with flat plate heatsink)	6SL3211-0KB13-7BB0	B	A ²⁾	²⁾
0.55	0.75	7.7	3.2	FS A	Analog	6SL3211-0AB15-5UA0	6SL3211-0AB15-5BA0	B	A ²⁾	²⁾
						6SL3211-0AB15-5UB0	6SL3211-0AB15-5BB0	B	A ²⁾	²⁾
						6SL3211-0KB15-5UA0 (with flat plate heatsink)	6SL3211-0KB15-5BA0	B	A ²⁾	²⁾
						6SL3211-0KB15-5UB0 (with flat plate heatsink)	6SL3211-0KB15-5BB0	B	A ²⁾	²⁾
0.75	1.0	10.0	3.9 (at 40 °C)	FS A	Analog	6SL3211-0AB17-5UA0	6SL3211-0AB17-5BA0	B	A ²⁾	²⁾
						6SL3211-0AB17-5UB0	6SL3211-0AB17-5BB0	B	A ²⁾	²⁾
						6SL3211-0KB17-5UA0 (with flat plate heatsink)	6SL3211-0KB17-5BA0	B	A ²⁾	²⁾
						6SL3211-0KB17-5UB0 (with flat plate heatsink)	6SL3211-0KB17-5BB0	B	A ²⁾	²⁾
1.1	1.5	14.7	6.0	FS B	Analog	6SL3211-0AB21-1UA0	6SL3211-0AB21-1AA0	B	A ²⁾	A ²⁾
						6SL3211-0AB21-1UB0	6SL3211-0AB21-1AB0	B	A ²⁾	A ²⁾
1.5	2.0	19.7	7.8 (at 40 °C)	FS B	Analog	6SL3211-0AB21-5UA0	6SL3211-0AB21-5AA0	B	A ²⁾	A ²⁾
						6SL3211-0AB21-5UB0	6SL3211-0AB21-5AB0	B	A ²⁾	A ²⁾
2.2	3.0	27.2	11.0	FS C	Analog	6SL3211-0AB22-2UA0	6SL3211-0AB22-2AA0	B	A ²⁾	A ²⁾
						6SL3211-0AB22-2UB0	6SL3211-0AB22-2AB0	B	A ²⁾	A ²⁾
3.0	4.0	35.6	13.6 (at 40 °C)	FS C	Analog	6SL3211-0AB23-0UA0	6SL3211-0AB23-0AA0	B	A ²⁾	A ²⁾
						6SL3211-0AB23-0UB0	6SL3211-0AB23-0AB0	B	A ²⁾	A ²⁾

The current data applies for an ambient temperature of 50 °C unless otherwise specified.

For SINAMICS G110 inverters the last digit of the full Order no. indicates the version type. As a result of product development, this digit may differ from the one specified when ordering.

All SINAMICS G110 inverters are supplied without a Basic Operator Panel (BOP). Any Basic Operator Panel or other options have to be ordered separately.

- 1) The value applies to the rated mains voltage of 230 V.
- 2) Class B also with additional filter.

Frequency inverters

Dimensional drawings

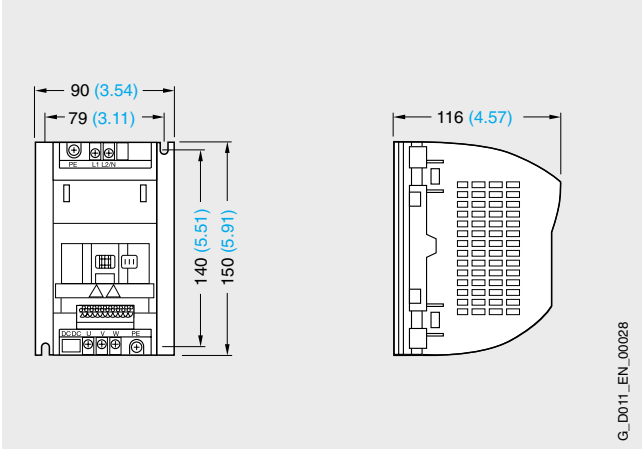

FS A inverter; 0.12 kW to 0.37 kW

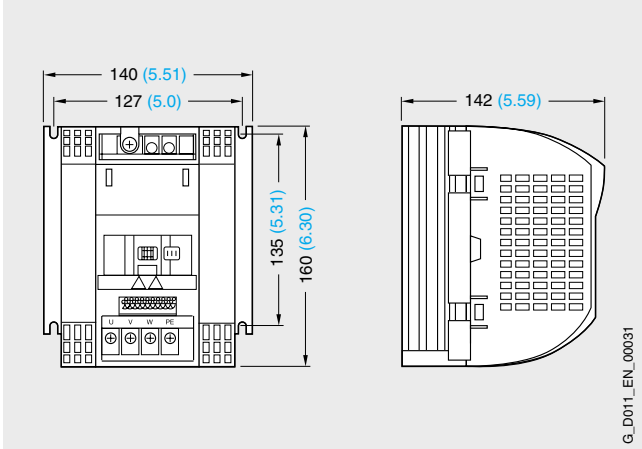

FS B inverter; 1.1 kW to 1.5 kW

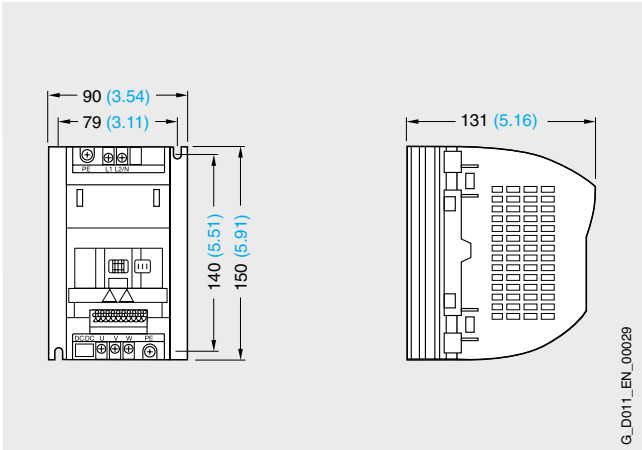

FS A inverter; 0.55 kW to 0.75 kW

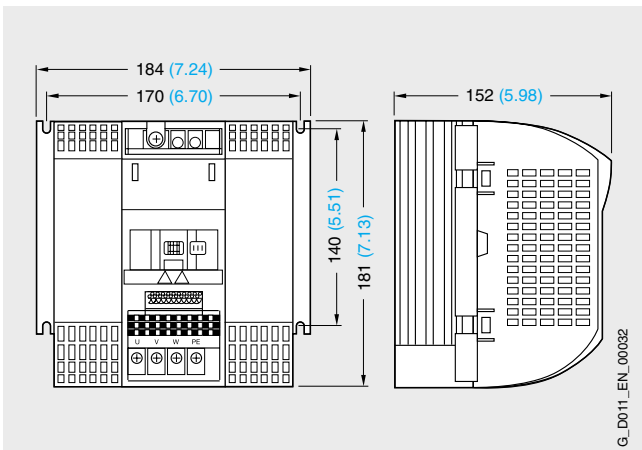

FS C inverter; 2.2 kW to 3.0 kW

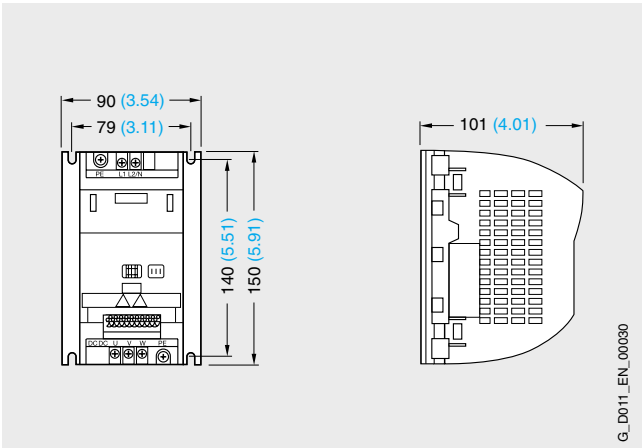

FS A inverter with flat plate heatsink; 0.12 kW to 0.75 kW

With plugged Basic Operator Panel (BOP), the mounting depth increases by 8 mm (0.31 inches).
 All dimensions are in mm (values in brackets are in inches).

SINAMICS G110

Chassis units

Frequency inverters

Schematic

General circuit diagram

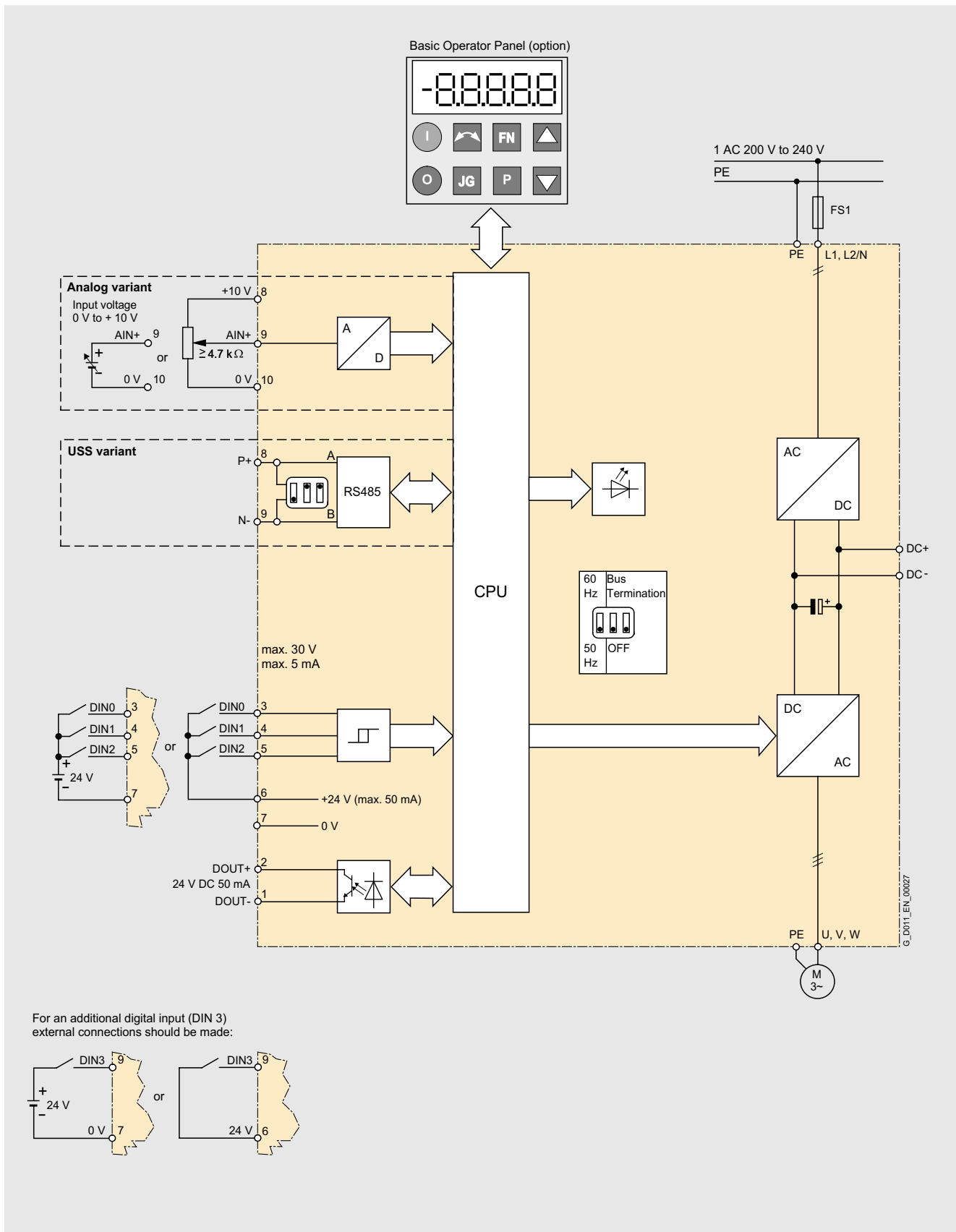

For an additional digital input (DIN 3) external connections should be made:

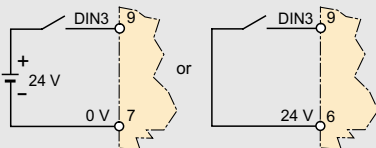

Overview

Internal EMC filter

Variants with internal EMC filter for both Class A and Class B environments are available.

• Class A

For Class A the requirements are fulfilled using shielded cables with a maximum length of 10 m (for FS A) or 25 m (for FS B and FS C). The limits comply with EN 55 011 Class A.

• Class B

For Class B the requirements are fulfilled using shielded cables with a maximum length of 5 m. The limits comply with EN 55 011 Class B.

An inverter with an internal filter can be used with a 30 mA residual-current circuit-breaker, and is only suitable for hardwired installations.

A non-filtered inverter together with the optional "Class B with low leakage currents filter" has a leakage current of < 3.5 mA (shielded motor cable up to 5 m).

Supplementary Class B EMC filter

Available for inverters with an internal Class A EMC filter.

With this filter, the inverter complies with the emission standard EN 55 011, Class B.

The requirements are fulfilled using shielded cables with a max. length of 25 m.

Class B filter with low leakage currents

With this filter, the unfiltered inverter complies with the emission standard EN 55 011, Class B. The leakage currents are reduced to < 3.5 mA.

Unfiltered inverters can be used for power drive systems in category C1 installations (general availability).

The requirements are fulfilled with

- shielded cables with a max. length of 5 m
- installation of the inverter in a metal enclosure (e.g. control cabinet)
- 16 kHz pulse frequency (frame size B and C only)

For category C1 installations, a 16 kHz pulse frequency is generally recommended for ultrasonic operation and low motor noise.

Line reactor

Line reactors are used to smooth voltage peaks or to bridge commutating dips.

In addition, line reactors reduce the effects of harmonics on the inverter and the power supply.

If the ratio of inverter rated power to mains short-circuit power is less than 1%, a line reactor must be used in order to reduce the current peaks.

According to EN 61 000-3-2 "Limits for harmonic currents with device input current ≤ 16 A per phase", there are special considerations for drives with 120 W to 550 W and 230 V single-phase supplies which are used in non-industrial applications (1st environment).

For devices with 120 W to 370 W, users must either fit the recommended line reactors or apply to the power utility company for authorization to connect the devices to the public power supply.

No limits are currently defined in the EN 61 000-3-2 standard for professionally used devices with a connected load > 1 kW. This means that inverters with an output power ≥ 0.75 kW comply with the EN 61 000-3-2 standard.

SINAMICS G110

Chassis units

Variant dependent options

Selection and Ordering Data

The options listed here are inverter-specific. EMC filters and line reactors have to be mounted separately.

The inverter and the associated options have the same voltage ratings.

All the inverter-specific supplementary components listed here are certified to UL, except fuses. 3NA3 fuses are recommended for European use.

Use in America requires UL listed fuses, for example the Class NON range from Bussmann.

Output		Order no. of the options				
kW	hp	Class B filter with low leakage currents	Line reactor	Supplementary Class B EMC filter	Fuse	Circuit-breaker
Options for inverters without filter						
0.12	0.16	6SE6400-2FL01-0AB0	6SE6400-3CC00-4AB3	-	3NA3803	3RV1021-1DA10
0.25	0.33	6SE6400-2FL01-0AB0	6SE6400-3CC00-4AB3	-	3NA3803	3RV1021-1FA10
0.37	0.50	6SE6400-2FL01-0AB0	6SE6400-3CC01-0AB3	-	3NA3803	3RV1021-1HA10
0.55	0.75	6SE6400-2FL01-0AB0	6SE6400-3CC01-0AB3	-	3NA3803	3RV1021-1JA10
0.75	1.0	6SE6400-2FL01-0AB0	6SE6400-3CC01-0AB3	-	3NA3805	3RV1021-1KA10
1.1	1.5	6SE6400-2FL02-6BB0	6SE6400-3CC02-6BB3	-	3NA3807	3RV1021-4BA10
1.5	2.0	6SE6400-2FL02-6BB0	6SE6400-3CC02-6BB3	-	3NA3810	3RV1021-4CA10
2.2	3.0	6SE6400-2FL02-6BB0	6SE6400-3CC02-6BB3	-	3NA3814	3RV1031-4EA10
3.0	4.0	-	6SE6400-3CC03-5CB3	-	3NA3820	3RV1031-4FA10
Options for inverters with internal filter Class A/B						
0.12	0.16	-	6SE6400-3CC00-4AB3	6SE6400-2FS01-0AB0	3NA3803	3RV1021-1DA10
0.25	0.33	-	6SE6400-3CC00-4AB3	6SE6400-2FS01-0AB0	3NA3803	3RV1021-1FA10
0.37	0.50	-	6SE6400-3CC01-0AB3	6SE6400-2FS01-0AB0	3NA3803	3RV1021-1HA10
0.55	0.75	-	6SE6400-3CC01-0AB3	6SE6400-2FS01-0AB0	3NA3803	3RV1021-1JA10
0.75	1.0	-	6SE6400-3CC01-0AB3	6SE6400-2FS01-0AB0	3NA3805	3RV1021-1KA10
1.1	1.5	-	6SE6400-3CC02-6BB3	6SE6400-2FS02-6BB0	3NA3807	3RV1021-4BA10
1.5	2.0	-	6SE6400-3CC02-6BB3	6SE6400-2FS02-6BB0	3NA3810	3RV1021-4CA10
2.2	3.0	-	6SE6400-3CC02-6BB3	6SE6400-2FS02-6BB0	3NA3814	3RV1031-4EA10
3.0	4.0	-	6SE6400-3CC03-5CB3	6SE6400-2FS03-5CB0	3NA3820	3RV1031-4FA10

Variant independent options

Documentation

Overview

Basic Operator Panel (BOP)



The BOP can be used to make individual parameter settings. Values and units are shown on a 5-digit display. One BOP can be used for several inverters. It is directly plugged into the inverter. The BOP offers a parameter cloning function, which enables a parameter set from one inverter to be saved and then downloaded to another inverter.

PC to inverter connection kit

For controlling and commissioning an inverter directly from a PC if the appropriate software (STARTER) has been installed. Isolated RS232 adapter board for reliable point to point connection to a PC. It offers a 9-pin Sub-D connector and an RS232 standard cable (3 m).

Commissioning tool

STARTER is a graphic start-up tool for commissioning SINAMICS G110 frequency inverters under Windows NT/2000/XP Professional. Parameter lists can be read out, altered, stored, read in and printed.

Selection and Ordering Data

The options listed here are suitable for all SINAMICS G110 inverters.

Options	Order no.
Basic Operator Panel (BOP)	6SL3255-0AA00-4BA0
PC to inverter connection kit	6SL3255-0AA00-2AA0
Adapter for mounting on DIN rail, Size 1 (FS A)	6SL3261-1BA00-0AA0
Adapter for mounting on DIN rail, Size 2 (FS B)	6SL3261-1BB00-0AA0
STARTER commissioning tool on CD-ROM, including: operating instructions, parameter list, Getting Started Guide ¹⁾	6SL3271-0CA00-0AG0

Selection and Ordering Data

Type of documentation	Language	Order no.
Operating instructions ¹⁾ (paper version)	German	6SL3298-0AA11-0AP0
	English	6SL3298-0AA11-0BP0
	French	6SL3298-0AA11-0DP0
	Italian	6SL3298-0AA11-0CP0
	Spanish	6SL3298-0AA11-0EP0
Parameter list ¹⁾ (paper version)	German	6SL3298-0BA11-0AP0
	English	6SL3298-0BA11-0BP0
	French	6SL3298-0BA11-0DP0
	Italian	6SL3298-0BA11-0CP0
	Spanish	6SL3298-0BA11-0EP0
Getting Started Guide ¹⁾	Multilanguage	A paper version is supplied with each inverter.

¹⁾ Documentation is also available on the Internet at <http://www.siemens.com/sinamics-g110>

SINAMICS G110

Chassis units

Training

Overview



The people who operate, program and service these devices have special skills and knowledge regarding the efficient use of drive technology.

The training centers of the Automation and Drives Group train your employees so that they can master this innovative technology. Well-trained employees are motivated and are dedicated to optimizing automation solutions.

Our SINAMICS training is carried out on specially developed training devices in the training centers. In addition, training cases are available for mobile use by sales and servicing personnel, and can be ordered separately.

The courses are designed on a modular basis and are aimed at various target groups, but can also be tailored to individual customer requirements.

We offer courses for:

- managers, decision makers and sales personnel
- designers and project managers
- servicing specialists and operating and servicing personnel.

In addition to the standard courses in our training centers, we also offer individual courses, which are tailored to specific customer requirements and can also be carried out locally on request.

SINAMICS DR-SN-UEB overview course

This course was designed specifically for sales personnel and decision makers, who want to obtain a general overview of the SINAMICS and MICROMASTER 4 drive concept and its position in the world of Siemens drives.

The system overview starts with an introduction to the basics of motor and inverter technology.

The SIZER planning tool and the STARTER commissioning tool are introduced and illustrated with short exercises.

MICROMASTER 4 SD-MM4 commissioning and servicing course

MICROMASTER 4 and SINAMICS G110 have a unique configuration and start-up. This course is therefore recommended both for MICROMASTER 4 users and SINAMICS G110 customers.

MICROMASTER 4 and SINAMICS G110 inverters are available for practical exercises.

Further information

All SITRAIN training courses can be booked by calling

01805-235611

or using the following order data.

	Order no.
ITC catalog , German	E86060-K6850-A101-B4
List of dates and prices including course information on CD-ROM, German	E86060-P6850-A101-C7
SITRAIN course information system on a separate CD-ROM, German/English	E86060-D6850-A100-B9-7400

Contact

If you have further questions regarding the courses on offer, please contact the training office on

01805-235611

or visit our website at:

<http://www.siemens.com/sitrain>

Here you will find our full range of courses with the latest additional dates, details of course reservations and further information.

Siemens AG
Trainingscenter A&D
Gleiwitzer Str. 555
90475 Nürnberg-Moorenbrunn
Germany

Tel.: 01805-235611

Fax: 01805-235612

E-mail: A&D.kursbuero@nbgm.siemens.de

Training case

Starter kit

Overview



Within the modular SIDEMO case system for microsystems, there is also a training case for SINAMICS G110, which is designed for mobile use by sales and servicing personnel.

The training case is equipped with an analog variant of the SINAMICS G110 inverter.

The training case can be operated on its own or in combination with other demonstration systems, e.g. LOGO!, SIMATIC S7-200, SITOP DC-USV.

The training case therefore includes an instruction sheet on how to replace the inverter with an USS variant (not included in the scope of supply).

The demonstration systems are delivered in dark blue carrying cases with dimensions 400 x 300 x 210 mm (gross weight 12 kg). The carrying cases can be stacked.

Further information is available on the Internet at <http://www.siemens.com/sidemo>

Selection and Ordering Data

	Order no.
SINAMICS G110 training case (including Basic Operator Panel (BOP))	6AG1064-1AA03-0AA0

Overview



The SINAMICS G110 starter kit provides a low-cost introduction to the world of variable speed drives.

It comprises a stackable carrying case containing the following:

- Inverter (0.75 kW or 1.5 kW) with analog input and internal EMC filter
- Basic Operator Panel (BOP)
- PC to inverter connection kit
- Product brief, operating instructions and parameter list (paper version in German or English)
- STARTER commissioning tool on CD-ROM, including: operating instructions, parameter list and Getting Started Guide
- Screwdriver

Selection and Ordering Data

	Output	Language	Order no.
Starter kit in a stackable carrying case, including:	0.75 kW	German	6SL3200-0AB10-0AA0
	1.5 kW	German	6SL3200-0AB20-0AA0
• Inverter with analog input and internal EMC filter	0.75 kW	English	6SL3200-0AB30-0AA0
	1.5 kW	English	6SL3200-0AB40-0AA0
• Basic Operator Panel (BOP)			
• PC to inverter connection kit			
• Product brief, operating instructions and parameter list (paper version)			
• CD-ROM			
• Screwdriver			

SINAMICS G110

Chassis units

Appendix

A&D in the WWW



A detailed knowledge of the range of products and services available is essential when planning and configuring automation systems. It goes without saying that this information must always be fully up-to-date.

The Siemens Automation and Drives Group (A&D) has therefore built up a comprehensive range of information in the World Wide Web, which offers quick and easy access to all data required.

Under the address

<http://www.siemens.com/automation>

you will find everything you need to know about products, systems and services.

Easy Shopping with the A&D Mall



The A&D Mall is the virtual department store of Siemens AG in the Internet. Here you have access to a huge range of products presented in electronic catalogs in an informative and attractive way.

Data transfer via EDIFACT allows the whole procedure from selection through ordering to tracking of the order to be carried out online via the Internet.

Numerous functions are available to support you.

For example, powerful search functions make it easy to find the required products, which can be immediately checked for availability. Customer-specific discounts and preparation of quotes can be carried out online as well as order tracking and tracing.

Please visit the A&D Mall on the Internet under:

<http://www.siemens.com/automation/mall>

Online Support



The comprehensive information system available round the clock via Internet ranging from Product Support and Service & Support services to Support Tools in the Shop.

<http://www.siemens.com/automation/service&support>

Service On Site



With Service On Site we offer services for startup and maintenance, essential for ensuring system availability.

In Germany
0180 50 50 444 ¹⁾

Technical Support



Competent consulting in technical questions covering a wide range of customer-oriented services for all our products and systems.

Tel.: +49 (0)180 50 50 222
Fax: +49 (0)180 50 50 223
E-Mail:
adsupport@siemens.com

Repairs and Spare Parts



In the operating phase of a machine or automation system we provide a comprehensive repair and spare parts service ensuring the highest degree of operating safety and reliability.

In Germany
0180 50 50 448 ¹⁾

¹⁾ For country-specific telephone numbers go to our Internet site at:
<http://www.siemens.com/automation/service&support>

Terms and Conditions of Sale and Delivery

By using this catalog you can acquire hardware and software products described therein from the Siemens AG subject to the following terms. Please note! The scope, the quality and the conditions for supplies and services, including software products, by any Siemens entity having a registered office outside of Germany, shall be subject exclusively to the General Terms and Conditions of the respective Siemens entity.

for customers with a seat or registered office in Germany

The General Terms of Payment as well as the General Conditions for the Supply of Products and Services of the Electrical and Electronics Industry shall apply.

For software products, the General License Conditions for Software Products for Automation and Drives for Customers with Seat or registered Office in Germany shall apply.

for customers with a seat or registered office outside of Germany

The General Terms of Payment as well as the General Conditions for Supplies of Siemens, Automation and Drives for Customers with a Seat or registered Office outside of Germany shall apply.

For software products, the General License Conditions for Software Products for Automation and Drives for Customers with Seat or registered Office outside of Germany shall apply.

General

The prices are in € (Euro) ex works, exclusive packaging.

The sales tax (value added tax) is not included in the prices. It shall be debited separately at the respective rate according to the applicable legal regulations.

In addition to the prices of products which include silver and/or copper, surcharges may be calculated if the respective limits of the notes are exceeded.

Prices are subject to change without prior notice. We will debit the prices valid at the time of delivery.

The dimensions are in mm. Illustrations are not binding.

Insofar as there are no remarks on the corresponding pages, - especially with regard to data, dimensions and weights given - these are subject to change without prior notice.

Comprehensive Terms and Conditions of Sale and Delivery are available free of charge from your local Siemens business office under the following Order Nos.:

- 6ZB5310-0KR30-0BA0
(for customers based in the Federal Republic of Germany)
- 6ZB5310-0KS53-0BA0
(for customers based outside of the Federal Republic of Germany)

or download them from the Internet:

www.siemens.com/automation/mall

(Germany: A&D Mall Online-Help System)

Export regulations

The products listed in this catalog may be subject to European/German and/or US export regulations.

Therefore, any export requiring a license is subject to approval by the competent authorities.

According to current provisions, the following export regulations must be observed with respect to the products featured in this catalog:

AL	Number of the <u>German Export List</u> . Products marked other than "N" require an export license. In the case of software products, the export designations of the relevant data medium must also be generally adhered to. Goods labeled with an " <u>AL not equal to N</u> " are subject to a European or German export authorization when being exported out of the EU.
ECCN	<u>Export Control Classification Number</u> . Products marked other than "N" are subject to a reexport license to specific countries. In the case of software products, the export designations of the relevant data medium must also be generally adhered to. Goods labeled with an " <u>ECCN not equal to N</u> " are subject to a US re-export authorization.

Even without a label or with an "AL: N" or "ECCN: N", authorization may be required due to the final destination and purpose for which the goods are to be used.

The deciding factors are the AL or ECCN export authorization indicated on order confirmations, delivery notes and invoices.

Errors excepted and subject to change without prior notice.

Responsible for
Technical contents:
Siemens AG, A&D SD SM, Erlangen
General editing:
Siemens AG, A&D PT 5, Erlangen

Siemens AG
Automation & Drives
Standard Drives
Postfach 3269
D-91050 Erlangen
Germany

Order No.: **E86060-K5511-A111-A1-7600**
Printed in Germany
KG K 1203 30.0 BD 20 En/422223



The information provided in this catalog contains descriptions or characteristics of performance which in case of actual use do not always apply as described or which may change as a result of further development of the products. An obligation to provide the respective characteristics shall only exist if expressly agreed in the terms of contract. Availability and technical specifications are subject to change without notice.

Siemens AG

Automation and Drives

Standard Drives

Postfach 32 69, D-91050 Erlangen

www.siemens.com/sinamics-g110

Order No. E86060-K5511-A111-A1-7600