

## Ordering information codes

		Code
<b>Model</b>	48 x 48 mm	95
<b>Outputs</b>	SSd / relay	00
	relay / relay	11
	SSd / SSd	22
	4-20mA / relay	B1
	4-20mA / ssd	B2
	0-5V / relay	C1
	0-5V / ssd	C2
	0-10V / relay	D1
	0-10V / ssd	D2
	<b>Output 3</b>	Always relay
<b>Programmer</b>		P
<b>Inputs</b>	Sensor	A
	4-20mA	B
	0-5V	C
	0-10V	D
<b>Communications</b>	None fitted	0
	RS232 fitted	2
	RS485 fitted	4
<b>Unused</b>		00

Ordering example 1	Ordering example 2
Model 9500P ssd/relay/relay outputs 4-20mA input, RS485 fitted	Model 9500 with 4-20mA/ssd/relay outputs, sensor input, no comms
95 00 1 P B 4 00	95 B2 1 P A 0 00

Codes for additional software and hardware	
CALgrafix	10 02 GB 0 0 0 0
CALgrafix Professional	10 03 GB 0 0 0 0
Communications board RS232	3C 00 00 2 0 0 0
Communications board RS485	3C 00 00 4 0 0 0
RS232 to RS485 converter	3C 25 00 0 K 3
CALopc OPC server	10 05 GB 0 0 0 0
CALpoll	Available on the web

### Ask for these brochures for our other product ranges



**Temperature Controllers**  
This low-cost range is dedicated for temperature control and also has the added options for RS232 & RS485 communications boards. All controllers have P.I.D. control, autotune, heat-cool strategy and a single ramp-soak profile.



**Temperature Sensors**  
This comprehensive catalogue is full of useful information as well as a wide range of thermocouples and RTDs for all applications. Also included is a range of accessories from cables, connectors, glands to thermowells.

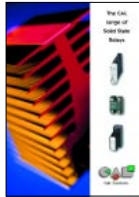

**Solid State Relays**  
This range of solid-state relays completes the solution from sensors to control output. This catalogue shows a range of hockey-puck style SSRs and the Soltron range with built-in heat sinks that are easy to specify and install.

Your nearest CAL contact;



**CAL Controls Ltd**  
Bury Mead Road, Hitchin, Herts, SG5 1RT. UK  
Tel: + 44 (0)1462-436161 Fax: + 44 (0)1462-451801  
email: sales@cal-controls.co.uk  
http://www.cal-controls.com

**CAL Controls Inc**  
1117 S. Milwaukee Avenue, Libertyville, IL 60048. USA  
Tel: (847) 680-7080 Fax: (847) 816-6852  
email: sales@cal-controls.com  
http://www.cal-controls.com

a VIDA GROUP company



## The CAL 9500P Programmable Profiling Temperature & Process Controller



# The CAL 9500P Programmable Temperature / Process Controller with Communications & Software Support

## CAL innovators in control

Established in 1963, CAL is a dynamic and strong company leading the industry in single-loop controllers. CAL's pioneering spirit established many of today's world standards for controllers such as the first 48mm x 48mm (1/16" DIN) analogue controller, followed by the first digital controller of the same size and then the first 24mm x 48mm (1/32" DIN) controller.

CAL's range of easy-to-use controllers are complemented by a suite of software products for communications, data-logging and supervisory control.

CAL has developed a reputation based on product support, innovation and attractively-styled controllers that enhance our customers' equipment, panels and machines.

**Note:**  
Standard colour is Jade Green, other colours are subject to minimum order quantities.



## The CAL 9500P programmable process controller

The CAL 9500P is a versatile programmable controller for temperature and process control applications. It is designed to offer the highest functionality in a 48mm x 48mm (1/16" DIN) package.

The 9500P can be factory configured in a range of process control or temperature control options making the controller dedicated to the application, ideal for both OEM and manufacturing process applications.

This combination of programmable ramp/soak profiles, process control inputs and 3 outputs, together with RS232 or RS485 comms makes the CAL 9500P a unique and affordable package.

### Controller functionality

- Full P.I.D. operation
- Autotune at 75% of set-point or at set-point
- Heat-cool operation
- RS232 or RS485 communications options
- CE, UL & CSA compliant

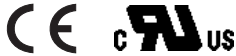

### Inputs

- Thermocouples & RTD (PT100, 2 or 3 wire)
- Analogue – 0-20mA, 4-20mA, 0-50mV, 0-5V, 0-10V

### Easy to scale input signals

CAL has made the task of scaling inputs very simple:  
**example:** 4-20mA = 60-260 units, where 4mA = 60 units  
**note:** 4-20mA corresponds to an input range of 10-50mV  
**Step 1,** enter scale max' = 260,  
**Step 2,** enter scale min' = 60,  
**Step 3,** enter input max' = 50 (i.e. 50mV = 20mA)  
**Step 4,** enter input min' = 10 (i.e. 10mV = 4mA).

### Outputs (total of three outputs)

- Solid state relay drive (SSD) and Relays (2 amp)
- Analogue – 4-20mA, 0-5V, 0-10V

**3-YEAR WARRANTY**

Visit our website for - pdf technical manuals, application notes, tutorials and much more

[www.cal-controls.com](http://www.cal-controls.com)

## Programmer functionality

- Up to 31 programs (profiles)
  - Up to 126 segments
  - Unlimited use of event outputs via the 2nd and 3rd outputs
  - Copy/Paste/Edit/Delete functions to simplify program building
  - Call another program as a sub-program segment
  - Up to 999 program loop cycles, or continuous loop cycling
  - Hold back function, to ensure the next segment is not started until the last segment reaches the set-point
  - 3 power fail recovery options, (Hold, Continue or Reset)
  - Front panel interrogation of the program position
  - Memory usage indication during programming.
- (note: program capacity is a memory function and different types of segment use more/less memory).

## Profile of a single program

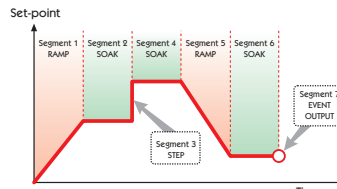

### Subset of the functions list:

- hold Suspends program until run
- on Run program
- Edit Insert, delete or copy programs

### Power failure modes

- rSET Reset to program start
- Cont Continue from interruption
- hold Hold at interruption

### Segment types

- SPr Ramp to next set-point
- SoAK Hold set-point for set time
- STEP Step to new set-point
- LoOP Repeat the program
- CALL Call up another program
- E.oP Generate an event output at end of segment
- Edit Delete or insert a segment

### Hold back function

- hb.u Hold back, this function 'holds back' the ramping set-point until the measured value catches up with the ramping set-point. This function ensures that the time taken to ramp does not reduce the next segment.

## Memory Allocation Table

Function	Memory Usage
Ramp	4 Bytes
Ramp with Holdback	5 Bytes
Soak	2 Bytes
Step	3 Bytes
Loops (1-3)	1 Byte
Loop (4+)	2 Bytes
Call	1 Byte
Event Output	1 Byte
Program Header	1 Byte

### Examples:

Maximum capacity; 351 Bytes, 126 segments per program, 31 programs

**Example 1** (349 Bytes)  
One program of 116 segments (58 ramps, 58 soaks)



**Example 2** (340 Bytes)  
4 programs of 28 segments (14 ramps, 14 soaks)



**Example 3** (341 Bytes)  
31 programs of (ramp-soak-ramp)

The above ramps are without hold-back option

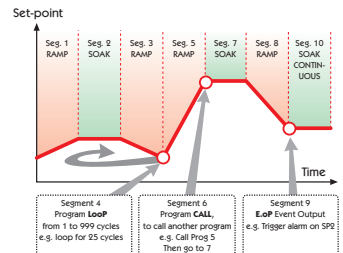

The CAL 9500P is potentially the most versatile and flexible controller in its size and price range. The above program shows what is possible from this unique controller.

[www.cal-controls.com](http://www.cal-controls.com)

## Software and Connectivity

Using CAL controllers there's a wide range of software support products designed to suit different applications.

Product	CALgrafix	CALopc	CALpoll
Description	Easy to use and install software application requiring no design work.	Software driver for OPC client/server applications such as SCADA.	Example demo program plus source code to help you build a custom application.
Ideal for:	Chart-recorders, Data-logger, Alarms, Programming 9500P profiles	Large SCADA applications requiring many inputs other than CAL	Custom software applications dedicated to one application.
For use by:	Plant/Process engineers, Supervisors, Quality control, System/Machine designers	Process engineers, Plant managers, SCADA system builders.	Software engineers with Visual C experience
Typical applications	Quality control, Process optimisation, Lab equipment	Process control, Manufacturing	OEM machines, development projects
License cost	\$	\$	Gratis/web
Development cost	\$	\$\$\$	\$\$\$\$\$\$
Flexibility/versatility	✓✓✓	✓✓✓	✓✓✓✓✓
	Connect to other h/w	Connect to other h/w	As flexible as the s/w
Other comments	Designed for simplicity with many features	User must also purchase the SCADA software	For use with Visual C ++ Compiler

### Terminology:

<b>SCADA</b>	Supervisory Control And Data Acquisition
<b>OPC</b>	Object Linking and Embedding for Process Control
<b>OEM</b>	Original Equipment Manufacturer

### CALopc – OPC server

The CALopc server is a MODBUS RTU software product designed for integration into OPC client/server applications such as SCADA. CALopc includes pre-configured templates for all CAL controllers, together with controller bitmaps and the 7-segment LED true type font.

Using this OPC server allows 'tags' to be added to all controller functions and built into the SCADA application enabling the display and changing of any parameters in a custom configured application for complete process monitoring and control.



### CALpoll – tools for custom software engineers

CALpoll is a free of charge software product available from [www.cal-controls.com](http://www.cal-controls.com) It includes an example program and source code in Visual C++.

It is ideal for use by software engineers who wish to create custom applications that need to communicate with CAL controllers via the MODBUS RTU protocol.

The source code includes routines for communicating via MODBUS saving the software engineer significant development time. The example program also doubles as an ideal diagnostic tool for proving that the communications hardware is set up correctly.

For further details please contact CAL.

Visit our website for - pdf technical manuals, application notes, tutorials and much more

## CALgrafix Process Monitoring and Configuration Software

CALgrafix is cost-effective process monitoring and controller configuration software that provides added value to using CAL's range of temperature and process controllers.

### Functions

- Data-logger with archiving process data
- Chart-recorder for on-screen viewing of trends
- Virtual instrument display
- On-screen alarm displays with audible notification
- A unique drag'n'drop feature for programming 9500P profiles
- 'Cloning' of instrument settings
- Saving of applications of multiple controller set-ups
- Configuration/programming tool for controllers
- OPC client/server architecture



### Example of networked controller configuration into CALgrafix

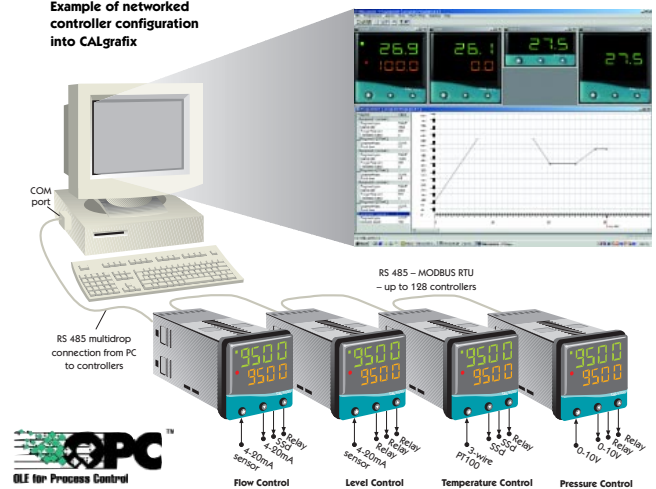

### Ideal for:

Recording process data for manufacturing reporting, quality control, health & safety purposes, or OEM system development.

### Applications:

Food industry, Dairy industry, Carbon fibre, Glass, Rubber & Plastics manufacturing, Ovens, Furnaces, Kilns, Autoclaves, Environmental cabinets, Plastics machines, Laboratory and Scientific equipment, Bottling and beverage production and many other process industries.

[www.cal-controls.com](http://www.cal-controls.com)

[www.cal-controls.com](http://www.cal-controls.com)

## CAL 9500P Specifications

<b>Thermocouple</b>	
9 types:	B, E, J, K, L, N, R, S, T
Standards:	IEC 584-1-1 : EN60584-1
CJC rejection:	20:1 (0.05°C) typical
External resistance:	100Ω maximum
<b>Resistance thermometer</b>	
RTD/Pt100	2 or 3 wire
Standards:	IEC751: EN60751 (100Ω 0°C/138.5Ω 100°C Pt)
Bulb current:	0.2mA maximum
<b>Analogue process inputs</b>	0 to 50mV <sub>r</sub> +/- 0.1%. 0-20mA, 4-20mA, +/- 0.1%. 0-5V, +/- 0.1%. 0-10V, +/- 0.1%
<b>Applicable to all Thermocouple and RTD inputs (SM = sensor maximum)</b>	
Calibration accuracy:	+/- 0.25% SM +/- 1°C
Sampling frequency:	Input 10Hz, CJC 2 sec.
Common mode rejection:	Negligible effect up to 140dB, 240V, 50-60Hz
Series mode rejection:	60dB, 50-60Hz
Temperature coefficient:	50ppm/°C SM typical
Reference conditions:	22°C +/- 2°C, rated voltage after 15 minutes settling time.
<b>Output devices (check configuration)</b>	
SSd1 and SSd2:	Solid state relay driver: To switch a remote SSR 6Vdc (nominal) 20mA non-isolated
Relay 1,2,3	Miniature power relay: Form A/SPST contacts (AgCdO): 2A/250Vac resistive load
Analogue output:	4-20mA 500Ω max +/- 0.1% full scale typical 0-5Vdc 10mA (500Ω min) +/- 0.1% full scale typical 0-10Vdc 10mA (1KΩ min) +/- 0.1% full scale typical
<b>General</b>	
Displays:	Upper, 4 Digits, high brightness green LED. 10mm (0.4") high. Lower, 4 Digits, high brightness orange LED 9mm (0.35") high. Digital range -199 to 9999. Hi-res mode -199.9 to 999.9. LED output indicators - SP1 square, green; SP2/SP3 round, red 3 elastomeric buttons
Keypad:	
<b>Programmer functions:</b>	
Segments:	Total of 126 per program
Programs:	Maximum of 31 programs
Program memory:	351 Bytes (see memory allocation table)
<b>Environmental</b>	
Humidity:	Max 95% non-condensing
Altitude:	up to 2000M
Installation:	Categories II and III
Pollution:	Degree II
Protection:	NEMA 4X, IP66 (Front panel only)
EMC emission:	EN50081-1 FCC Rules 15 subpart J Class A
EMC immunity:	EN50082-2
Ambient:	0-50°C (32-130°F)
Mouldings:	flame retardant polycarbonate
Weight:	180g (6.4 oz)
Safety:	EN61010-1/CSA22.2 No 1010.1 92 (see users manual)
<b>Dimensions</b>	
Front fascia:	51.0 x 51.0mm (2.0" x 2.0") (includes gasket)
Sleeve length:	106.7mm (4.2") (with gasket fitted)
Instrument body:	44.8 x 44.8mm (1.76" x 1.76")
Overall length:	116.2mm (4.57")
<b>Supply Voltage:</b>	100-240Vac, 50-60Hz +/- 10% maximum permitted fluctuation
<b>Power Requirements:</b>	6.0VA (nominal)

## Technical Specifications

### Typical Application

In this example the load temperature is monitored by a temperature transducer/transmitter which provides a 4-20mA input signal to the controller. The 4-20mA output has been allocated to SP1 to drive an SCR power controller providing a phase angle controlled output to the heater.

**F1 Fuse:** 1A time lag type to IEC127. CSA/UL rating 250Vac

**F2 Fuse:** High Rupture Capacity (HRC) Suitable for maximum rated load current

**S1 Switch:** IEC/CSA/UL Approved disconnecting device.

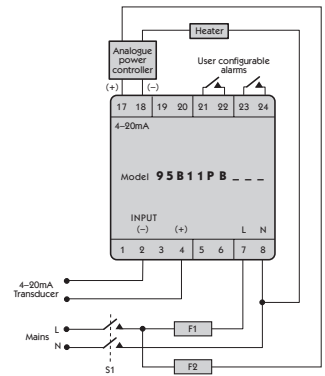

### Model 9500P

(48x48mm) 1/16 DIN

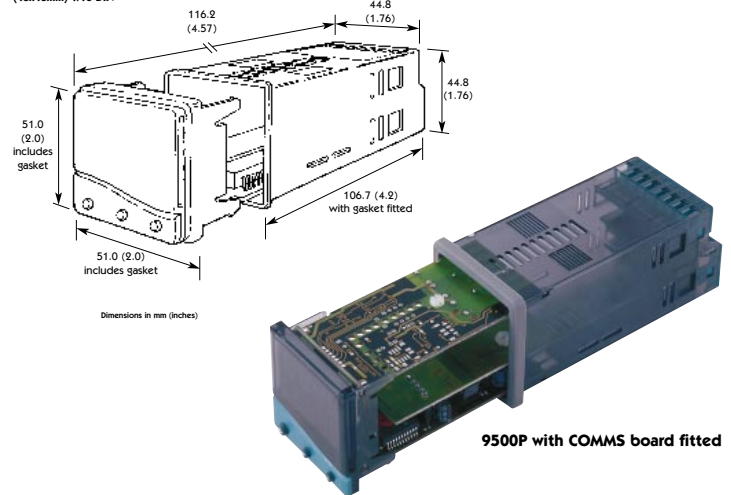

Visit our website for - pdf technical manuals, application notes, tutorials and much more

[www.cal-controls.com](http://www.cal-controls.com)

[www.cal-controls.com](http://www.cal-controls.com)