

SNAP B-Series Racks

Features

- Secure mounting for SNAP I/O modules plus a SNAP brain or on-the-rack SNAP controller
- Analog, digital, and serial modules on the same rack
- Panel or DIN-rail mounting
- Modules snap into place

Description

NOTE: For racks to use with SNAP PAC controllers and brains, see Opto 22 form #1684, the *SNAP PAC Racks Data Sheet*.

NOTE: M-series racks (such as the SNAP-M64), used with SNAP Simple brains and SNAP-UP1-M64 controllers, have been replaced by SNAP PAC racks. See form #1684.

SNAP B-series mounting racks are designed to hold an intelligent SNAP I/O processor—either a SNAP brain or an on-the-rack controller—and several I/O modules.

This rack family includes racks that are compatible with ARCNET and serial SNAP brains, including those using Modbus® and Profibus® protocols, and with some Ethernet-based SNAP Ultimate I/O™ on-the-rack controllers and SNAP Ethernet I/O™ brains. For specific processor compatibility, see “Specifications” on page 3.

Since SNAP analog, digital, and serial I/O modules have the same footprint, customers using most SNAP B-series racks can mix modules on the same I/O mounting rack. However, module types, features, and positions on the rack vary depending on the capabilities of the brain or on-the-rack controller used. See the brain or controller data sheet for details.

Field devices are wired directly to the top-mounted removable connectors on the modules plugged into each rack. SNAP B-series racks can accommodate up to 4, 8, 12, or 16 modules. The module and rack design allows modules to simply “snap” on and off the mounting rack.

SNAP racks use a retention rail locking system that holds modules securely to the rack. Normally, a hold-down screw is not required. However, for applications that require additional module security, SNAP racks have provisions for two 4-40 by ½-inch standard machine screws to hold each module in position.

MC and MC-P model racks provide an auxiliary screw-type terminal strip for field wiring common connections such as loop power distribution. MC racks use a fixed terminal strip, while MC-P racks use removable connectors for easy maintenance (see enlarged view on the following page).

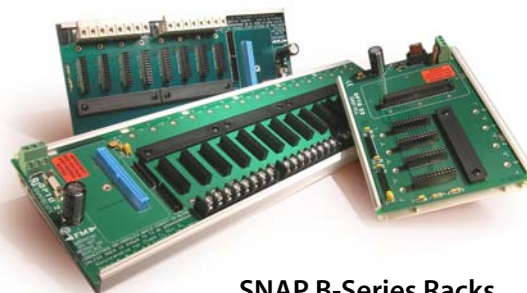

SNAP B-Series Racks

All SNAP racks offer panel mounting and the option of DIN-rail mounting. SNAP racks require a 5 VDC power source.

SNAP-B4M, SNAP-B8M, SNAP-B12M, SNAP-B16M, and SNAP-D64RS racks are Factory Mutual approved.

Part Numbers

Part	Description
SNAP-B4M*	4-module rack
SNAP-B8M*	8-module rack
SNAP-B12M*	12-module rack
SNAP-B16M*	16-module rack
SNAP-B8MC	8-module rack with extra terminal block for field wiring
SNAP-B12MC	12-module rack with extra terminal block for field wiring
SNAP-B16MC	16-module rack with extra terminal block for field wiring
SNAP-B8MC-P	8-module rack with extra terminal block for field wiring, pluggable
SNAP-B12MC-P	12-module rack with extra terminal block for field wiring, pluggable
SNAP-B16MC-P	16-module rack with extra terminal block for field wiring, pluggable
SNAP-D64RS*	16-module rack for digital-only SNAP Ultimate, SNAP Ethernet, and SNAP-PDPRS64 Profibus brains
SNAP-FUSE7.5AB	7.5-amp fuse, 25-pack
SNAP-FUSE4AB	4-amp fuse, 25-pack
SNAP-FUSE1AB	1-amp fuse, 25-pack
SNAP-TEX-DRC10	SNAP PAC rack DIN-rail adapter clip, 10-pack
SNAP-TEX-REC10N	Narrow end cap for SNAP PAC racks DIN-rail assemblies, 10-pack
SNAP-TEX-REC10W	Wide end cap for SNAP PAC racks DIN-rail assemblies with terminal strips, 10-pack

* Factory Mutual (FM) approved

Description (continued)

SNAP-B8M (8-Module Position I/O Mounting Rack)

Shown with B3000 brain (purchased separately)

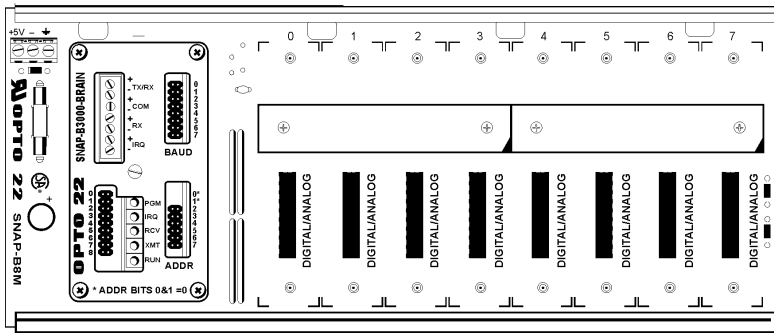

SNAP-B8MC (8-Module Position I/O Mounting Rack)

Shown with B3000 brain (purchased separately)

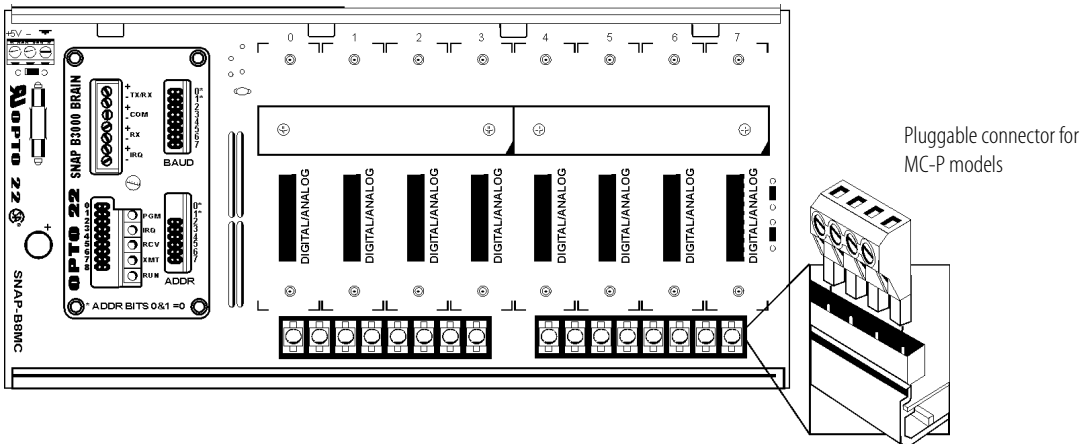

SNAP B-Series Racks

Specifications

Part Number	Description ¹	Power ² Requirements	I/O Processor ³ Compatibility	Replacement Fuse	Operating Temperature	Relative Humidity
SNAP-B4M	4-module mixed	5.0 to 5.2 VDC @ 1.8 Amps max	SNAP-UP1-ADS SNAP-B3000-ENET SNAP-ENET-RTC B3000 B3000-HA SNAP-B4 SNAP-B6 SNAP-BRS SNAP-BRS-HA SNAP-B3000-MODBUS	SNAP-FUSE4A or Bel ⁵ 5HF4	0 to 70 °C	95%, non-condensing
SNAP-B8M	8-module mixed	5.0 to 5.2 VDC @ 2.6 Amps max				
SNAP-B8MC	8-module mixed, terminal block					
SNAP-B8MC-P	8-module mixed, pluggable terminal block					
SNAP-B12M	12-module mixed ⁴	5.0 to 5.2 VDC @ 3.4 Amps max				
SNAP-B12MC	12-module mixed ⁴ , terminal block					
SNAP-B12MC-P	12-module mixed ⁴ , pluggable terminal block					
SNAP-B16M	16-module mixed ⁴	5.0 to 5.2 VDC @ 4.2 Amps max				
SNAP-B16MC	16-module mixed ⁴ , terminal block					
SNAP-B16MC-P	16-module mixed ⁴ , pluggable terminal block					
SNAP-D64RS	16-module digital only (limited digital functions)	5.0 to 5.2 VDC @ 1.8 Amps max	SNAP-UP1-D64 SNAP-ENET-D64 SNAP-PDPRS64	SNAP-FUSE1A or Buss ⁵ GDC1A		

1 "Mixed" means the rack can hold analog, digital, and serial modules. Most Ethernet-based I/O processors handle all these types of modules; other processors do not. See the processor's data sheet for details.

2 Power requirements shown are for a rack, a processor, and a full load of 2-channel analog modules (for the SNAP-D64RS, a full load of 4-channel digital modules). Power requirements for other SNAP modules are higher. See module data sheets.

3 "I/O Processor" means a SNAP brain or on-the-rack controller.

4 Four-channel SNAP digital modules can be used in positions 0–7 only.

5 Manufacturer's part number (not available through Opto 22).

Specifications (continued)

All models:
Power schematic
 For fuse part numbers,
 see Specifications on
[page 3](#).

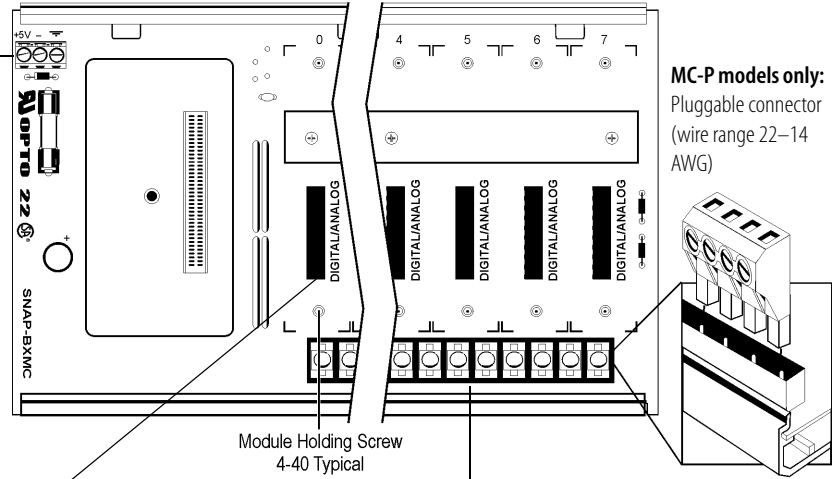
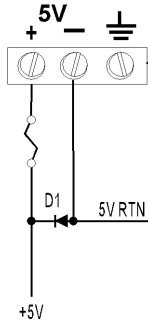

MC-P models only:
 Pluggable connector
 (wire range 22-14
 AWG)

All models: Module mating
 connector pinout (female)

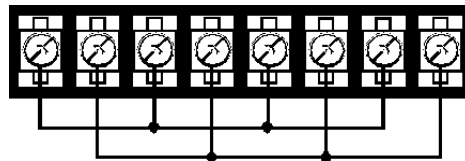
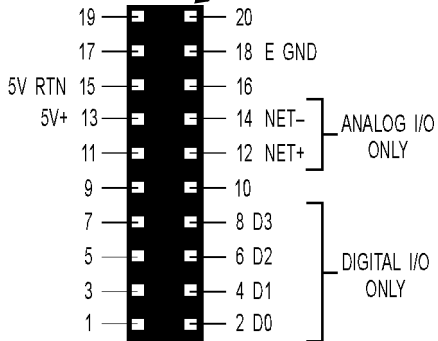

MC and MC-P models only: For detailed information on
 terminal strip usage, see [page 12](#) through [page 16](#).

SNAP B-Series Racks

Dimensional Drawings

Dimensions—SNAP-D64RS Rack and B-Series Racks with Terminal Strips

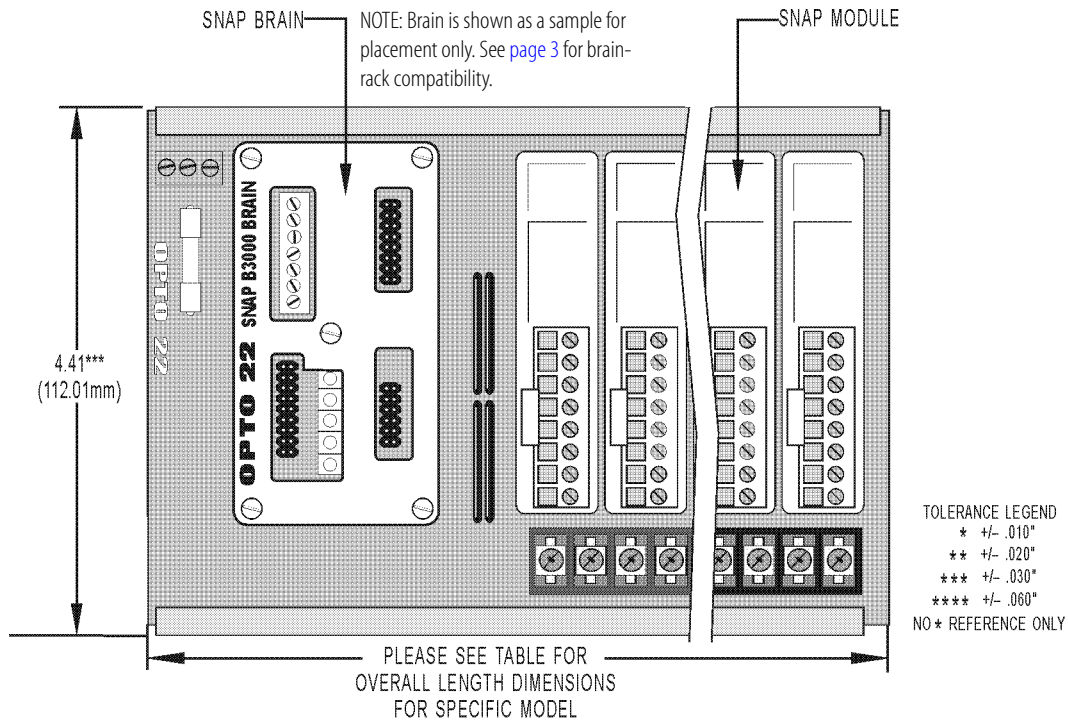

Overall Length Dimensions (SNAP-D64RS and B-series racks with terminal strips)

Part Number	Description	Width (inches)	Width (mm)	Length (inches)	Length (mm)
SNAP-B8MC SNAP-B8MC-P	8-module rack for other brains, with terminal block	4.41	112.01	9.25	234.95
SNAP-B12MC SNAP-B12MC-P	12-module rack for other brains, with terminal block	4.41	112.01	12.25	311.15
SNAP-B16MC SNAP-B16MC-P	16-module rack for other brains, with terminal block	4.41	112.01	15.25	387.35
SNAP-D64RS	16-module rack, digital only	4.41	112.01	15.25	387.35

Dimensional Drawings (continued)

Dimensions—B-Series Racks Without Terminal Strips

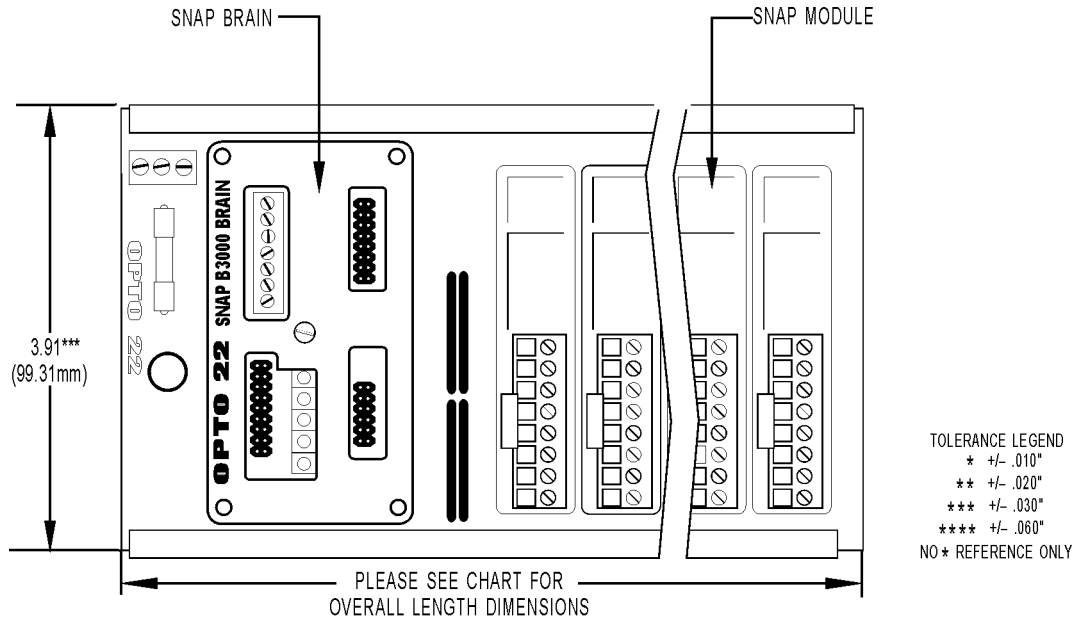

Overall Length Dimensions (B-series racks without terminal strips)

Part Number	Description	Width (inches)	Width (mm)	Length (inches)	Length (mm)
SNAP-B4M	4-module rack	3.91	99.31	6.24	158.41
SNAP-B8M	8-module rack	3.91	99.31	9.24	234.70
SNAP-B12M	12-module rack	3.91	99.31	12.24	310.90
SNAP-B16M	16-module rack	3.91	99.31	15.24	387.10

SNAP B-Series Racks

Dimensional Drawings (continued)

**SNAP-D64RS Rack and B-Series Racks with Terminal Strips:
Right Side View with DIN-Rail Option Installed**

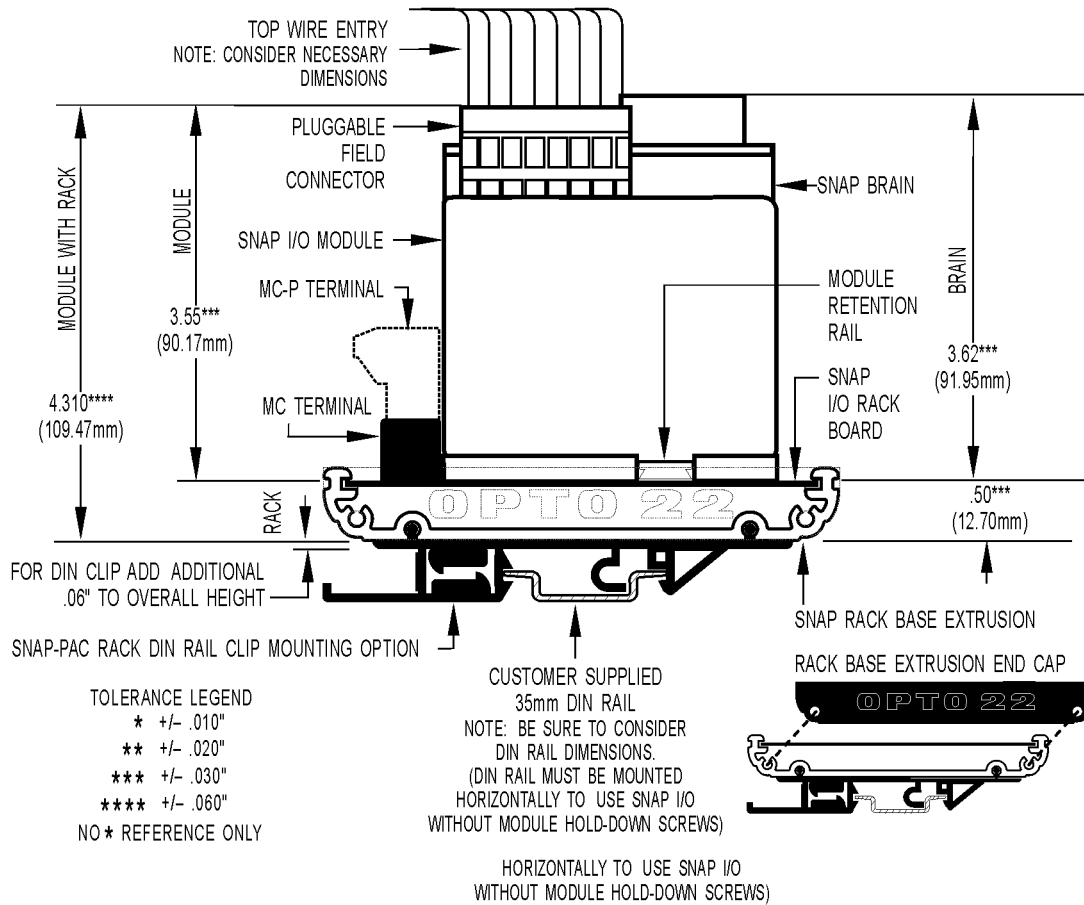

Processor Height*	Processor Part Number	Rack
4.12 in. (104.6 mm)	SNAP-UP1-ADS SNAP-B3000-ENET SNAP-ENET-RTC	B-series
	SNAP-UP1-D64 SNAP-ENET-D64	SNAP-D64RS
3.70 in. (95.9 mm)	B3000 B3000-HA SNAP-B4 SNAP-BRS-HA SNAP-B6 SNAP-B3000-MODBUS SNAP-BRS	B-series

* Height listed is from the processor's mounting surface to the highest part of the processor. Height does not include wiring or cables.

Dimensional Drawings (continued)

B-Series Racks Without Terminal Strips: Right Side View with DIN-Rail Option Installed

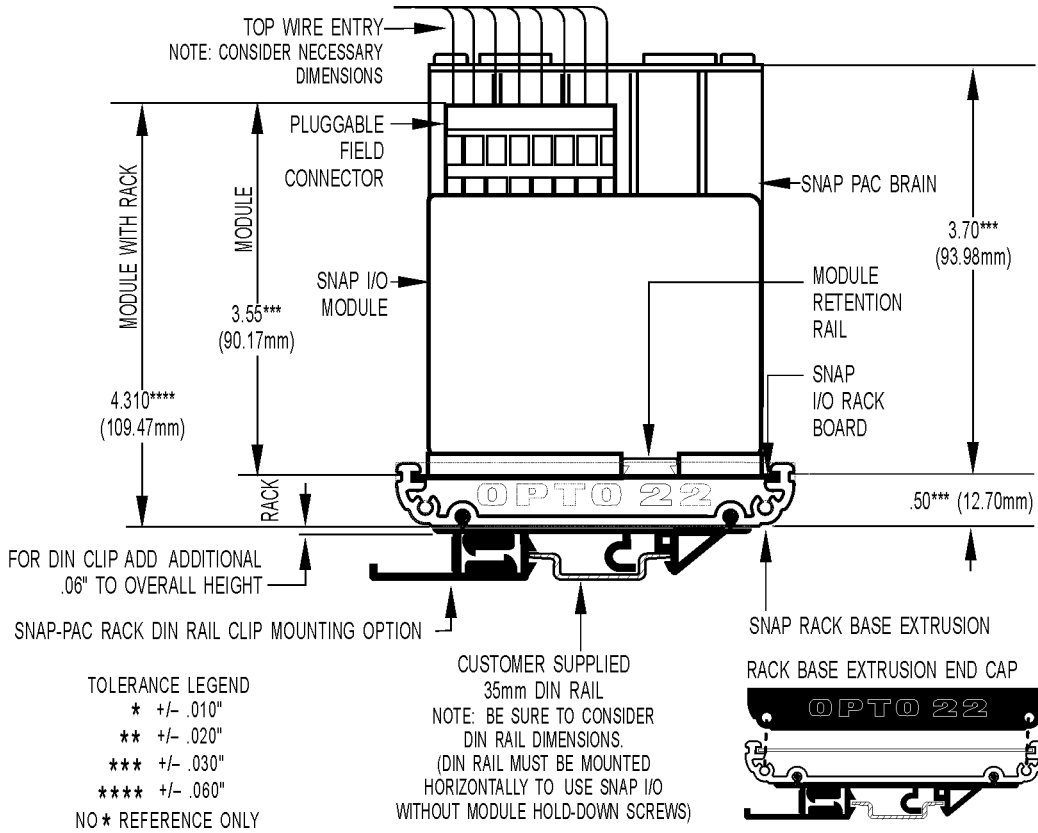

Processor Height*	Processor Part Number	
4.12 in. (104.6 mm)	SNAP-UP1-ADS SNAP-B3000-ENET	SNAP-ENET-RTC
3.70 in. (95.9 mm)	B3000 SNAP-B4 SNAP-B6 B3000-HA	SNAP-BRS SNAP-BRS-HA SNAP-B3000-MODBUS

* Height listed is from the processor's mounting surface to the highest part of the processor. It does not include wiring or cables.

SNAP B-Series Racks

Mounting

NOTE: If you are not using hold-down screws, the SNAP rack assembly should be mounted horizontally.

Use the following steps to mount racks as shown in the diagrams on the next two pages.

Preferred Method: Template

(Product on site)

1. Use SNAP rack mounting extrusion as template.
2. Be sure to use the diagrams on the next two pages to determine required product and option clearances.

Alternate Method: Prefabrication of Panels

(No product on site)

Mounting holes are in sets of two, located on lower left and upper right with respect to a center line (CL).

1. Using the diagrams on the next two pages, determine CL1 mounting hole positions. (CL1 is located on the left side of all SNAP rack mounting extrusions.)
2. Use the center-to-center length specification table below to determine the offset between center lines and the number of center line positions for each model.
3. Repeat the process for each center line position.

Center-to-Center Length (All Models)

Part Number	Description	Center-to-Center Length	Number of Center Positions
SNAP-B4M	4-module rack	4.01 in.	2
SNAP-B8M SNAP-B8MC SNAP-B8MC-P	8-module rack	3.51 in.	3
SNAP-B12M SNAP-B12MC SNAP-B12MC-P	12-module rack	5.01 in.	3
SNAP-B16M SNAP-B16MC SNAP-B16MC-P SNAP-D64RS	16-module rack	4.34 in.	4

Mounting (continued)

**SNAP-D64RS Rack and B-Series Racks with Terminal Strips:
Typical Plain View of SNAP Mounting Extrusion**

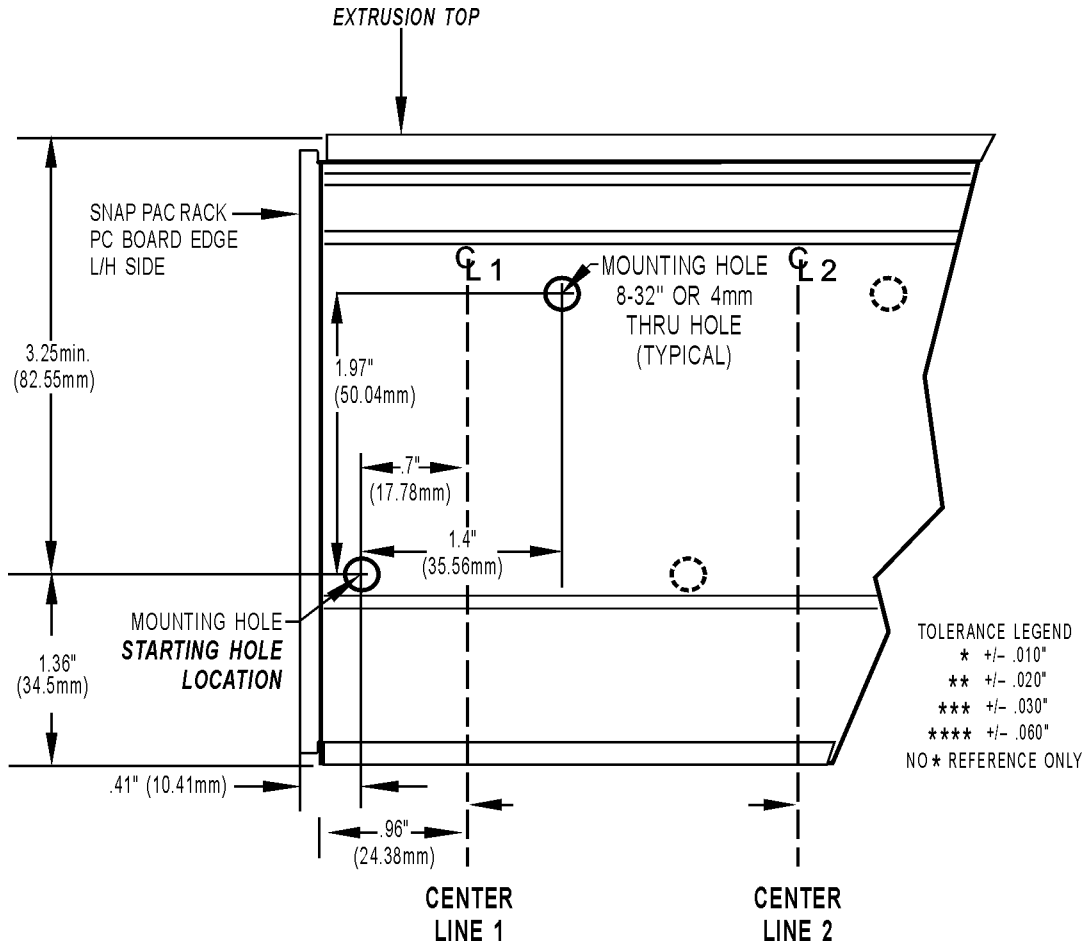

See instructions and table on [page 9](#).

SNAP B-Series Racks

Mounting (continued)

B-Series Racks Without Terminal Strips: Typical Plain View of SNAP Mounting Extrusion

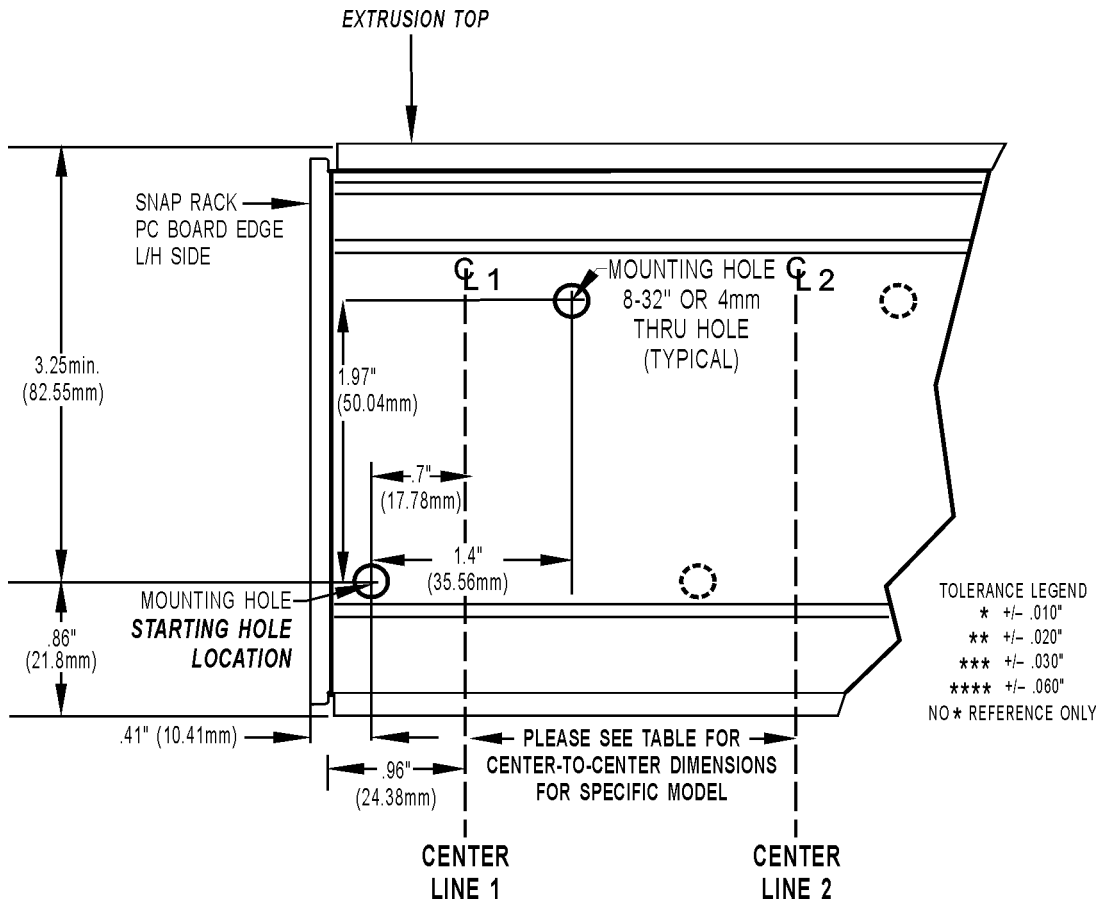

See instructions and table on [page 9](#).

Wiring Diagrams—B-Series Models with Terminal Strips

Terminal Strip Usage—Digital

NOTE: Consult the SNAP module data sheet for your specific module for additional wiring information.

Example: Digital Input Using Terminal Strip

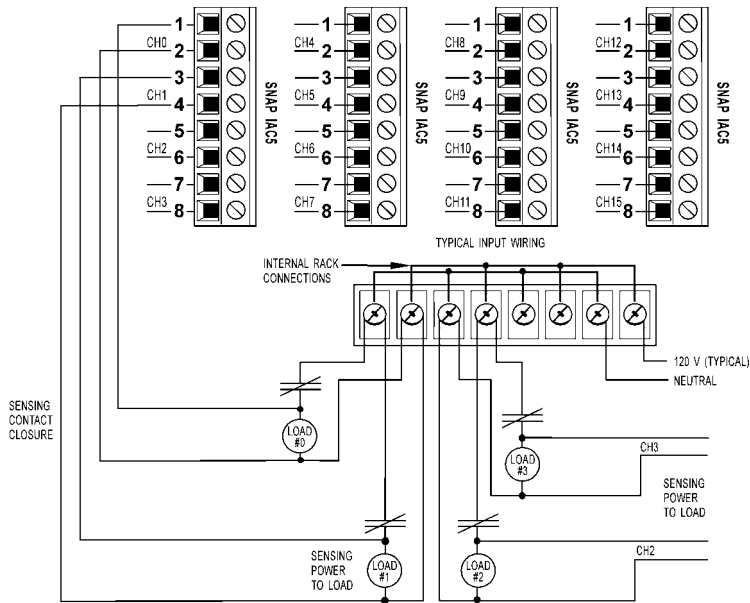

Example: Digital AC Output Using Terminal Strip

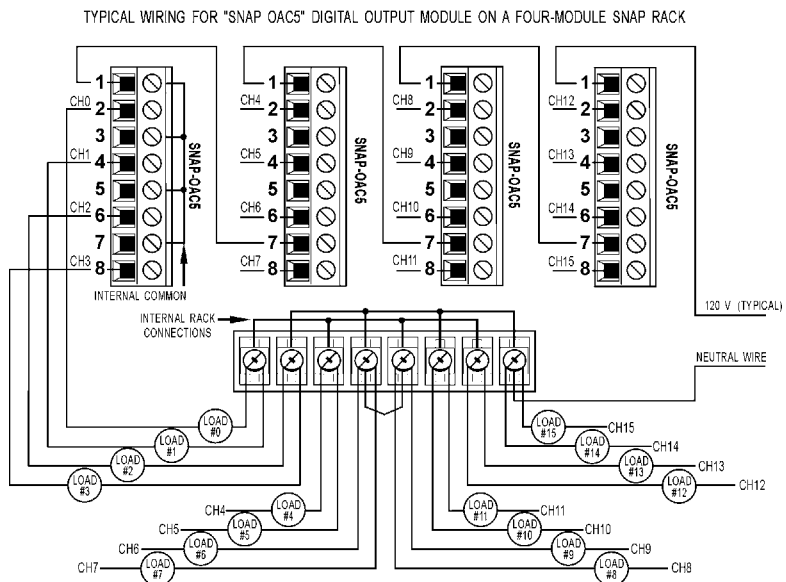

SNAP B-Series Racks

Wiring Diagrams—B-Series Models with Terminal Strips

Terminal Strip Usage—Digital (continued)

Example: Digital DC Output (Sourcing) Using Terminal Strip

NOTE: Consult the SNAP module data sheet for your specific module for additional wiring information.

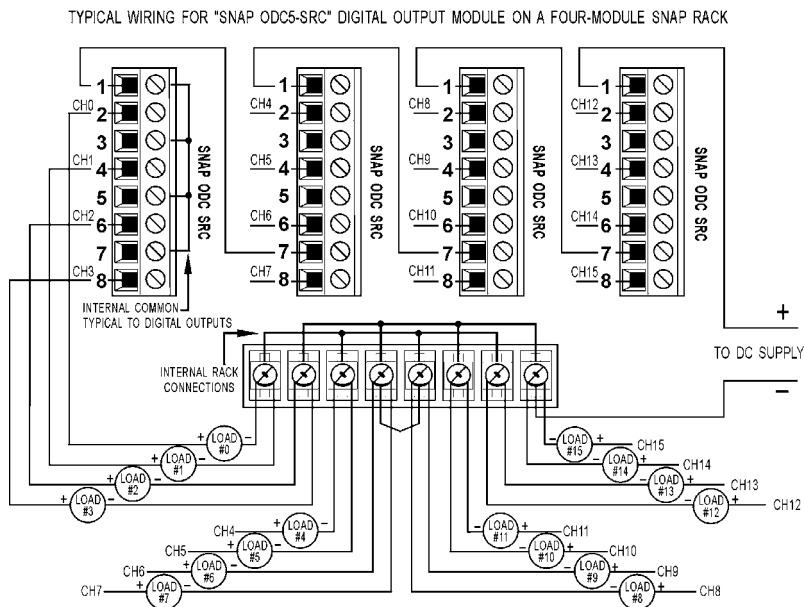

Example: Digital DC Output (Sinking) Using Terminal Strip

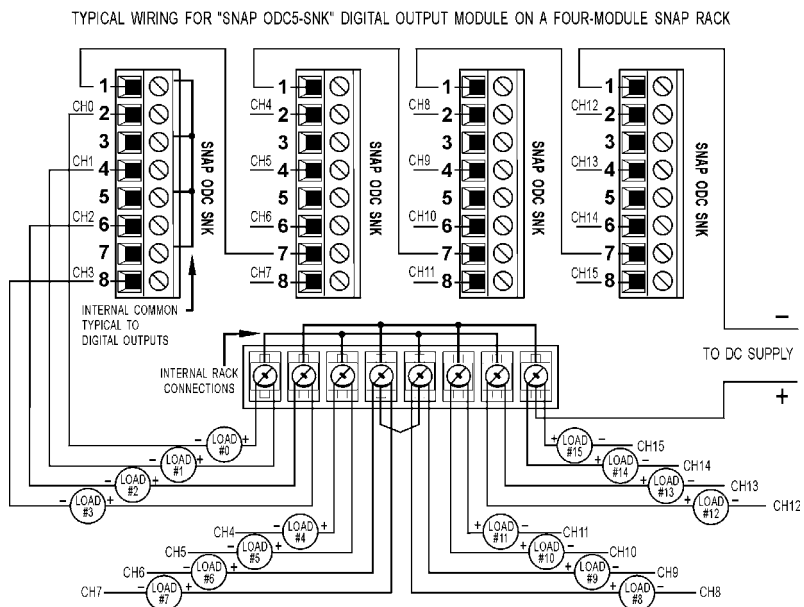

Wiring Diagrams—B-Series Models with Terminal Strips

Terminal Strip Usage—Analog

NOTE: Consult the SNAP module data sheet for your specific module for additional wiring information.

Example: Analog Input (Current: Negative) Using Terminal Strip

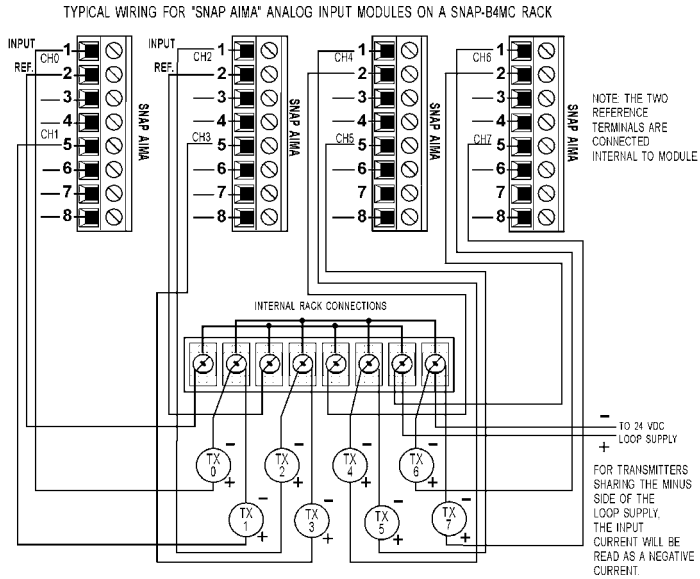

Example: Analog Input (Current: Positive) Using Terminal Strip

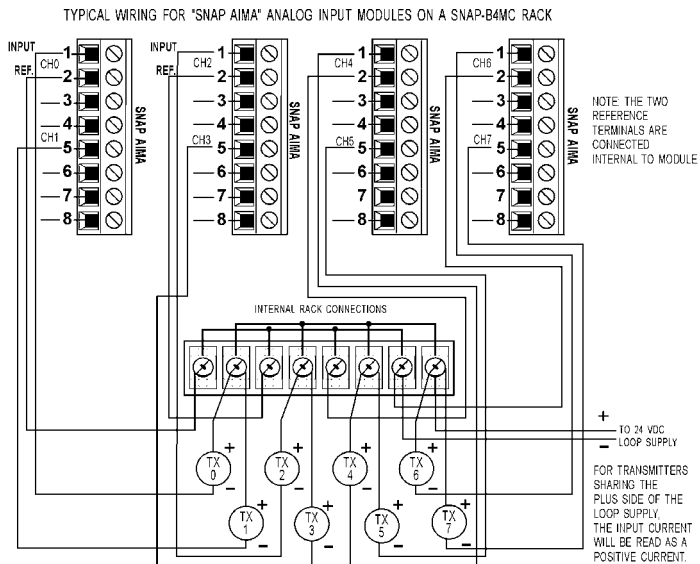

SNAP B-Series Racks

Wiring Diagrams—B-Series Models with Terminal Strips

Terminal Strip Usage—Analog (continued)

Example: Analog Output (4–20 mA Current: Sourcing) Using Terminal Strip

NOTE: Consult the SNAP module data sheet for your specific module for additional wiring information.

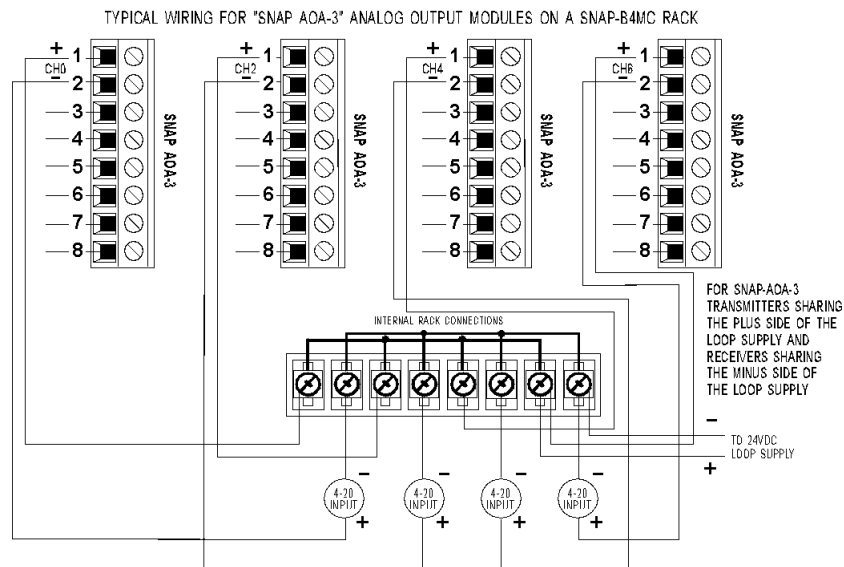

Example: Analog Output (4–20 mA Current: Sinking) Using Terminal Strip

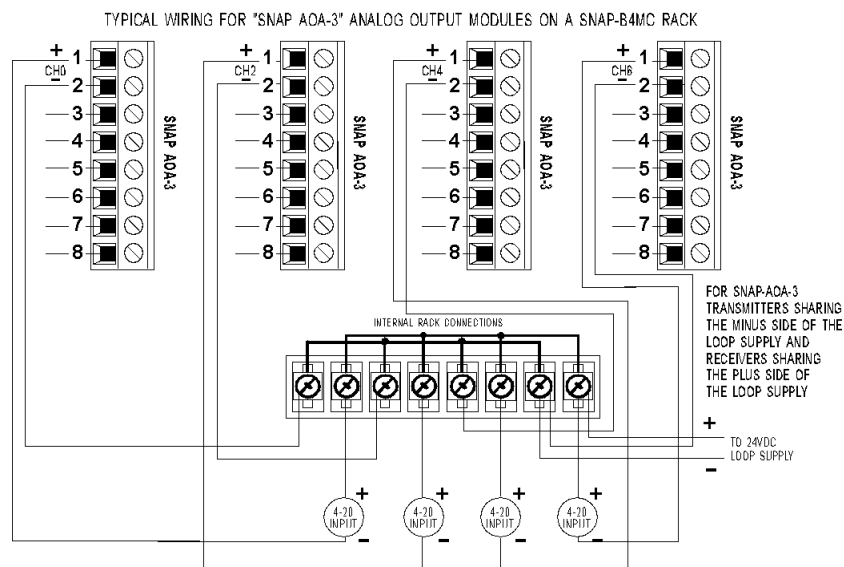

Wiring Diagrams—B-Series Models with Terminal Strips

Terminal Strip Usage—Analog (continued)

NOTE: Consult the SNAP module data sheet for your specific module for additional wiring information.

Example: Analog Input (Voltage) Using Terminal Strip

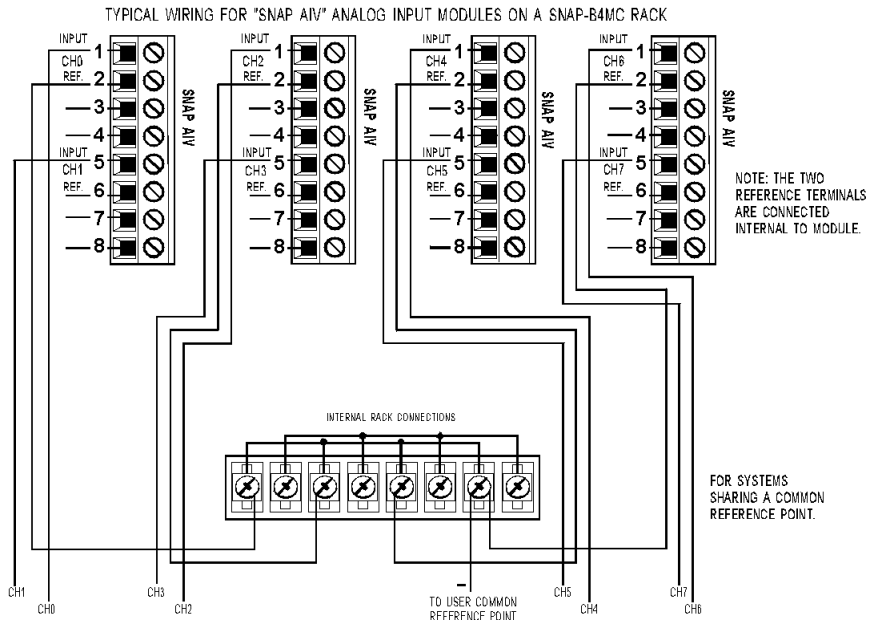

More About Opto 22

Products

Opto 22 develops and manufactures reliable, flexible, easy-to-use hardware and software products for industrial automation, remote monitoring, and data acquisition applications.

SNAP PAC System

Designed to simplify the typically complex process of understanding, selecting, buying, and applying an automation system, the SNAP PAC System consists of four integrated components:

- SNAP PAC controllers
- PAC Project™ Software Suite
- SNAP PAC brains
- SNAP I/O™

SNAP PAC Controllers

Programmable automation controllers (PACs) are multifunctional, multidomain, modular controllers based on open standards and providing an integrated development environment.

Opto 22 has been manufacturing PACs for many years. The latest models include the standalone SNAP PAC S-series and the rack-mounted SNAP PAC R-series. Both handle a wide range of digital, analog, and serial functions and are equally suited to data collection, remote monitoring, process control, and discrete and hybrid manufacturing.

SNAP PACs are based on open Ethernet and Internet Protocol (IP) standards, so you can build or extend a system without the expense and limitations of proprietary networks and protocols.

PAC Project Software Suite

Opto 22's PAC Project Software Suite provides full-featured and cost-effective control programming, HMI (human machine interface) development and runtime, OPC server, and database connectivity software to power your SNAP PAC System.

These fully integrated software applications share a single tagname database, so the data points you configure in PAC Control™ are immediately available for use in PAC Display™, OptoOPCServer™, and OptoDataLink™. Commands are in plain English; variables and I/O point names are fully descriptive.

PAC Project Basic offers control and HMI tools and is free for download on our website, www.opto22.com. PAC Project Professional, available for separate purchase, adds OptoOPCServer, OptoDataLink, options for Ethernet link redundancy or segmented networking, and support for legacy Opto 22 serial *mistic*™ I/O units.

SNAP PAC Brains

While SNAP PAC controllers provide central control and data distribution, SNAP PAC brains provide distributed intelligence for I/O processing and communications. Brains offer analog, digital, and serial functions, including thermocouple linearization; PID loop control; and optional high-speed digital counting (up to 20 kHz), quadrature counting, TPO, and pulse generation and measurement.

SNAP I/O

I/O provides the local connection to sensors and equipment. Opto 22 SNAP I/O offers 1 to 32 points of reliable I/O per module, depending on the type of module and your needs. Analog, digital, serial, and special-purpose modules are all mixed on the same mounting rack and controlled by the same processor (SNAP PAC brain or rack-mounted controller).

Quality

Founded in 1974 and with over 85 million devices sold, Opto 22 has established a worldwide reputation for high-quality products. All are made in the U.S.A. at our manufacturing facility in Temecula, California. Because we do no statistical testing and each part is tested twice before leaving our factory, we can guarantee most solid-state relays and optically isolated I/O modules for life.

Free Product Support

Opto 22's Product Support Group offers free, comprehensive technical support for Opto 22 products. Our staff of support engineers represents decades of training and experience. Product support is available in English and Spanish, by phone or email, Monday through Friday, 7 a.m. to 5 p.m. PST.

Free Customer Training

Hands-on training classes for the SNAP PAC System are offered at our headquarters in Temecula, California. Each student has his or her own learning station; classes are limited to nine students. Registration for the free training class is on a first-come, first-served basis. See our website, www.opto22.com, for more information or email training@opto22.com.

Purchasing Opto 22 Products

Opto 22 products are sold directly and through a worldwide network of distributors, partners, and system integrators. For more information, contact Opto 22 headquarters at 800-321-6786 or 951-695-3000, or visit our website at www.opto22.com.

www.opto22.com