

G4 Digital DC Output Modules

Features

- 4000 volts opticalisolation (transient)
- Built-in LED status indicator
- Logic levels of 5, 15, and 24 VDC
- Removable fuse
- Ability to withstand one-second surge of 5 amps
- Operating temperature: -30 °C to 70 °C
- UL recognized, CSA certified, CE approved
- Passes NEMA Showering Arc Test (ICS 2-230)
- Meets IEEE Surge Withstand Specification (IEEE-472)



G4ODC5

Description

Opto 22's G4 DC output modules are used to control or switch DC loads. Each module provides up to 4000 volts of optical isolation (transient) between field devices and control logic.

The G4ODC5MA is a special module featuring a manual-on/manual-off/automatic switch, ideal for diagnostic testing of control applications.

Typical applications for DC output modules include switching loads such as DC relays, solenoids, motor starters, lamps, and indicators.

Part Numbers

Part	Description
G4ODC5	G4 DC Output 5–60 VDC, 5 VDC Logic
G4ODC5FM	G4 DC Output 5–60 VDC, 5 VDC Logic, Factory Mutual approved
G4ODC5A	G4 DC Output 5–200 VDC, 5 VDC Logic
G4ODC5AFM	G4 DC Output 5–200 VDC, 5 VDC Logic, Factory Mutual approved
G4ODC5MA	G4 DC Output 5–60 VDC, 5 VDC Logic with Manual/Auto Switch
G4ODC15	G4 DC Output 5–60 VDC, 15 VDC Logic
G4ODC24	G4 DC Output 5–60 VDC, 24 VDC Logic
G4ODC24A	G4 DC Output 5–200 VDC, 24 VDC Logic

G4 Digital DC Output Modules

Specifications

	Units	G4ODC5 G4ODC5FM*	G4ODC5A G4ODC5AFM*	G4ODC5MA	G4ODC15	G4ODC24	G4ODC24A
Maximum line voltage	VDC	60	200	60	60	60	200
Output voltage range	VDC	5–60	5–200	5–60	5–60	5–60	5–200
Key feature	—	—	—	Diagnostic switch	—	—	—
Current rating: At 45 °C ambient	A	3	1	3	3	3	1
At 70 °C ambient	A	2	0.55	2	2	2	0.55
Isolation input-to-out- put (transient): 1 ms 1 minute	volts	4000 1500	4000 1500	4000 1500	4000 1500	4000 1500	4000 1500
Off-state leakage at maximum voltage	mA	1	1	1	1	1	1
Control resistance (R _c in schematic)	W	220	220	220	1 K	2.2 K	2.2 K
One-second surge	A	5	5	5	5	5	5
Turn-on time	micro- seconds	100	100	100	100	100	100
Turn-off time	micro- seconds	750	750	750	750	750	750
Output voltage drop maximum peak	V	1.6	1.6	1.6	1.6	1.6	1.6
Nominal logic voltage	VDC	5	5	5	15	24	24
Logic voltage range	VDC	4–8	4–8	4–8	10.5–16	19.5–32	19.5–32
Logic pickup voltage	VDC	4	4	4	10.5	19.5	19.5
Logic dropout voltage	VDC	1	1	1	1	1	1
Logic input current at nominal logic voltage	mA	12	12	12	15	18	18
Temperature: Operating	°C	-30 to +70	-30 to +70	-30 to +70	-30 to +70	-30 to +70	-3- to +70
Storage	°C	-30 to +85	-30 to +85	-30 to +85	-30 to +85	-30 to +85	-30 to +85

*Part numbers ending in FM are Factory Mutual approved.

G4 Digital DC Output Modules

Dimensions

All Models Except MA

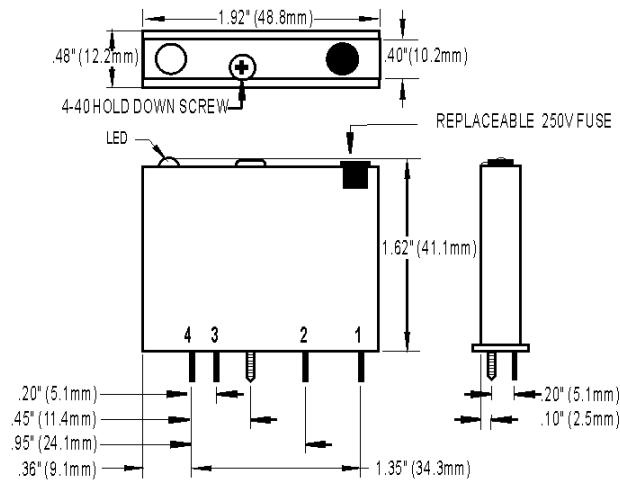

MA Models

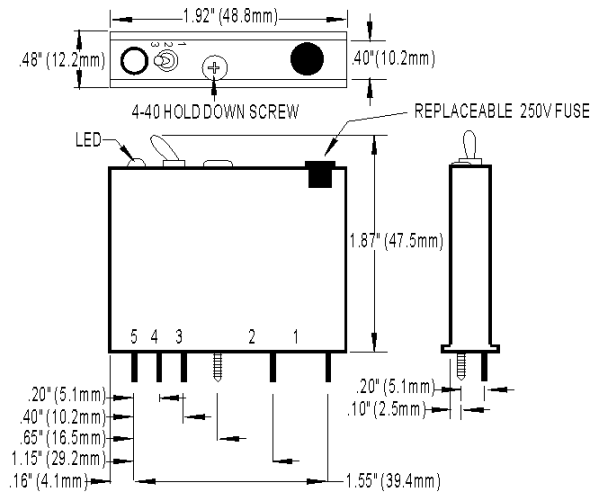

G4 Digital DC Output Modules

Schematics

All Models Except MA

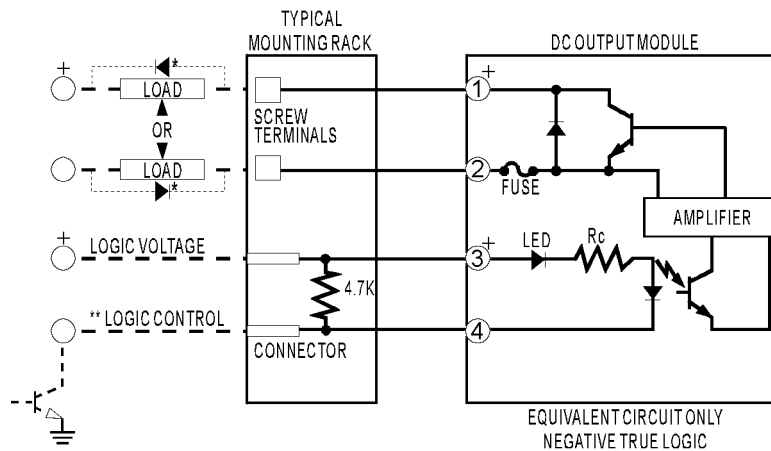

* Commutation diode must be used on inductive loads. Typically, use diode IN4005.
 ** Control line is compatible with totem pole or tri-state output device.

MA Models

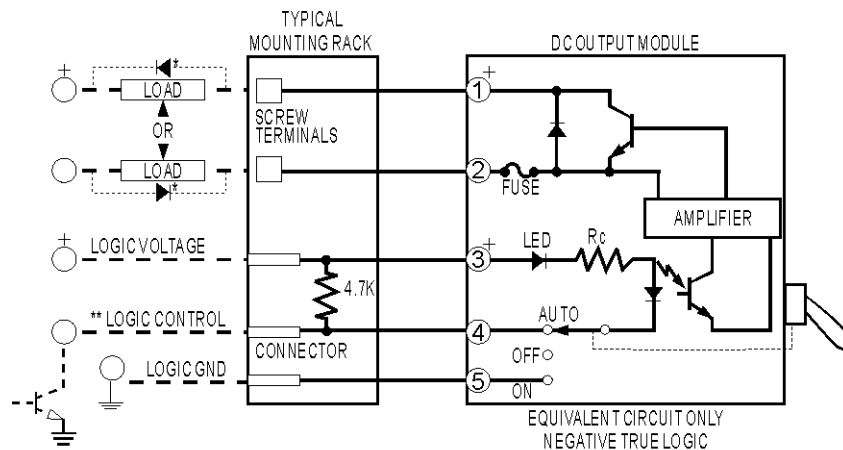

* Commutation diode must be used on inductive loads. Typically, use diode IN4005.
 ** Control line is compatible with totem pole or tri-state output device.