

LINE-MOUNTED FLOW MICRO-REGULATOR WITH PUSH-IN FITTING

Serie RFL R

The RFL R flow micro-regulator belongs to the LINE ON LINE® family and can be connected in series or in parallel with all the other products.

The RFL R regulates the air input and thus the speed in pneumatic actuators. Two versions are available:

- Type U (unidirectional) regulates the flow only in one of the two directions of air flow. The following types of fitting can be mounted:

- Push-in input and output fitting
- Push-in input fitting and threaded port on the exhaust (cylinder type)
- Input threaded port and push-in fitting on the exhaust (valve type)

- Type B (bidirectional) regulates the flow in both directions of air flow. The following types of fitting can be mounted:

- Push-in input and output fitting
- Threaded port and push-in fitting

There are four possible types of assembly (see example on the following page).



TECHNICAL DATA		Ø 4	Ø 6	Ø 8
Max. operating pressure	MPa		1	
	bar		10	
	psi		145	
Temperature range	°C		-20°C ÷ +60°C	
	°F		-4°F ÷ +140°F	
Max flow rate on regulation at 6.3 bar	NI/min	155	450	850
Flow rate on relief at 6.3 bar	NI/min	160	550	950
Adjustment		Manual or using a screwdriver		
Internal system		Tapered needle		
Recommended pipe		Rilsan PA 11 – Nylon 6 – Polyamide 12 - Polypropylene		
Fluid		Lubricated or unlubricated filtered air		

COMPONENTS

- ① Technopolymer body
- ② Nickel-plated brass seal support
- ③ NBR gasket
- ④ Brass adjusting needle
- ⑤ Nickel-plated brass needle ring nut
- ⑥ Wall fixing ring nut
- ⑦ NBR seal
- ⑧ Technopolymer spring ring
- ⑨ Stainless steel clip-on spring
- ⑩ Technopolymer stop bushing
- ⑪ Technopolymer release bushing

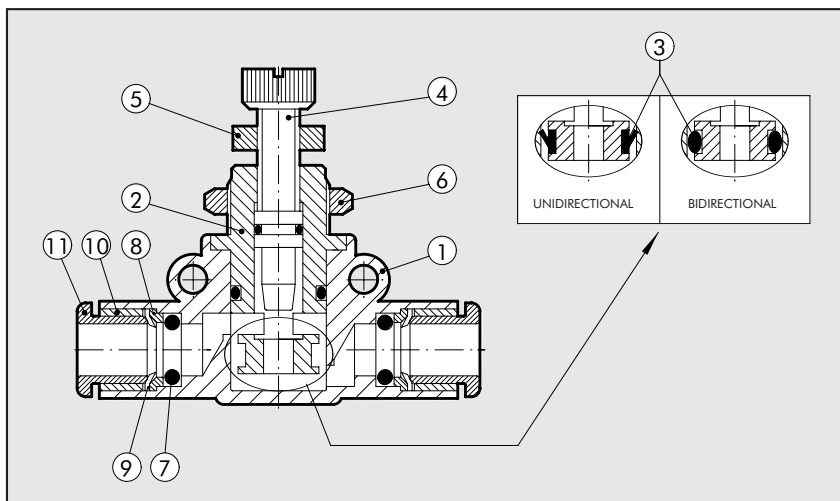



FLOW CHARTS

RFL R Ø 4

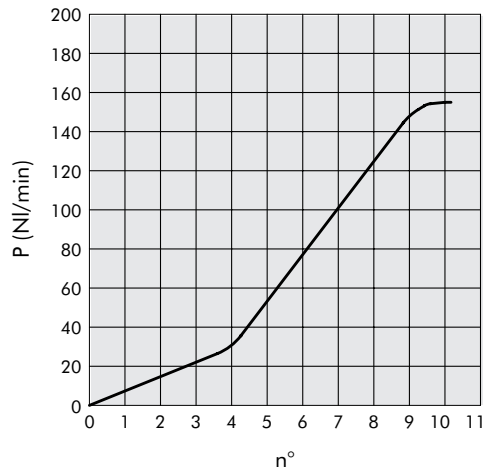

RFL R Ø 6

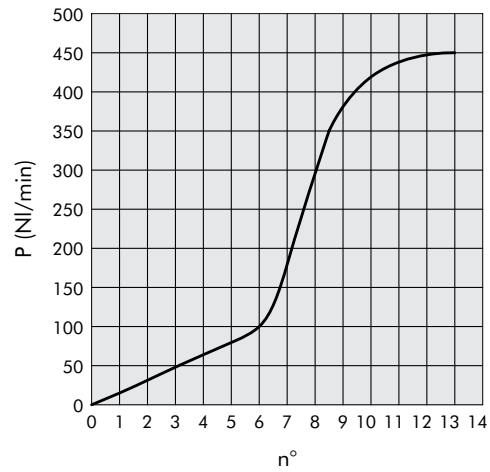

RFL R Ø 8

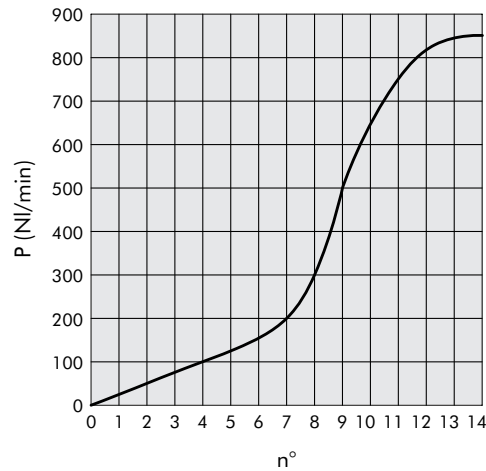

ASSEMBLY OPTIONS

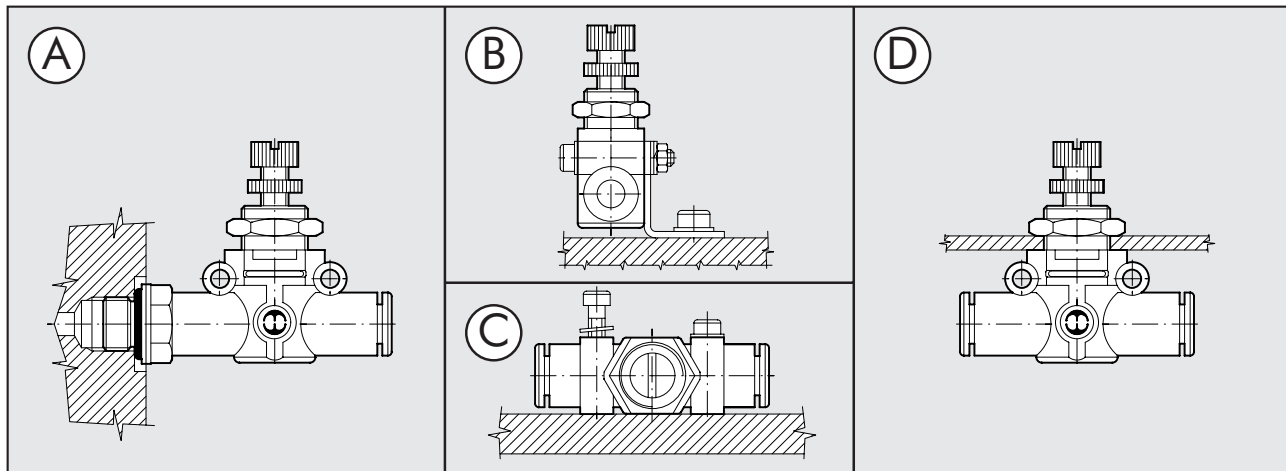

How to mount the RFL R:

- Fig. A: With the male threaded port it is possible to mount the RFL R straight onto the actuator or the control valve.
- Fig. B: Fixing to the plate with the special SQU L bracket.
- Fig. C: There are two robust rings on the plastic body for fixing the RFL R straight onto the wall.
- Fig. D: The ring nut is screwed onto the threaded metal part of the RFL R body for panel mounting.

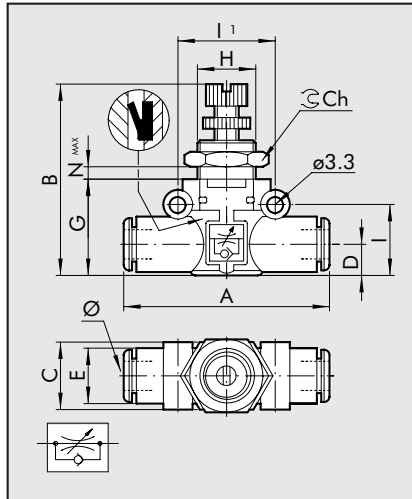
RFL R PIPE-PIPE UNIDIRECTIONAL

Code	Ref.	Ø	A	B	C	D	E	G	H	I	II	Ch	Nmax
9041301	RFL R U 4-4	4	40	33.5÷36.5	10.7	5.6	10	17.5	M9x0.75	12.8	16	11	4
9041316	RFL R U 6-6	6	47	36÷41	14.7	6.4	11.4	20	M12x0.75	14.6	20	15	4
9041324	RFL R U 8-8	8	55.5	44÷49	18.7	9.1	13.8	26	M15x1	18.7	24	20	4.5

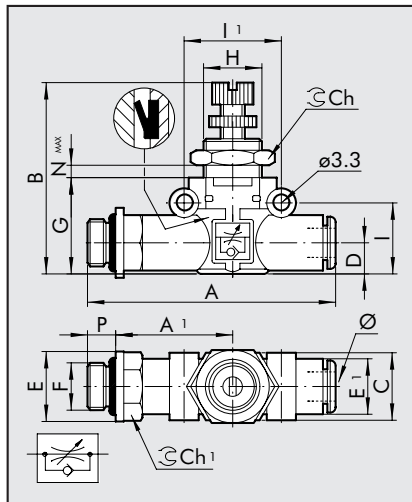
RFL R THREAD-PIPE UNIDIRECTIONAL CYLINDER VERSION

Code	Ref.	F	Ø	P	A	A1	B	C	D	E	E1
9041401	RFL R U M5-4	M5	4	4	46.7	22.7	33.5÷36.5	10.7	5.6	9.9	10
9041402	RFL R U 1/8-4	1/8	4	6	50.6	24.6	33.5÷36.5	10.7	5.6	14	10
9041408	RFL R U 1/8-6	1/8	6	6	57.3	27.8	36÷41	14.7	6.4	14	11.4
9041409	RFL R U 1/4-6	1/4	6	8	60.3	28.8	36÷41	14.7	6.4	18	11.4
9041410	RFL R U 1/8-8	1/8	8	6	65.3	31.8	44÷49	18.7	9.1	15	13.8
9041411	RFL R U 1/4-8	1/4	8	8	69.7	34.2	44÷49	18.7	9.1	18	13.8
9041412	RFL R U 3/8-8	3/8	8	9	71.3	34.8	44÷49	18.7	9.1	22	13.8

G	H	I	II	Ch	Ch1	Nmax
17.5	M9x0.75	12.8	16	11	9	4
17.5	M9x0.75	12.8	16	11	12	4
20	M12x0.75	14.6	20	15	12	4
20	M12x0.75	14.6	20	15	14	4
26	M15x1	18.7	24	20	14	4.5
26	M15x1	18.7	24	20	14	4.5
26	M15x1	18.7	24	20	17	4.5

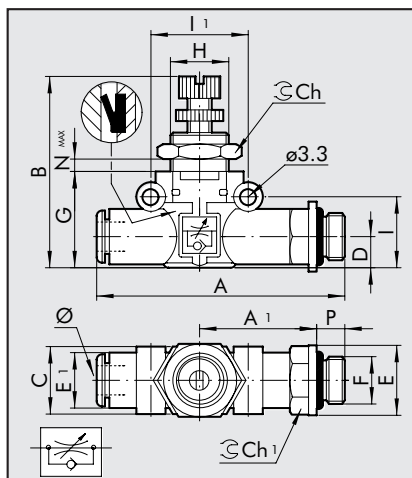
RFL R PIPE-THREAD UNIDIRECTIONAL VALVE VERSION

Code	Ref.	Ø	F	P	A	A1	B	C	D	E	E1
9041501	RFL R U 4-M5	4	M5	4	46.7	22.7	33.5÷36.5	10.7	5.6	9.9	10
9041502	RFL R U 4-1/8	4	1/8	6	50.6	24.6	33.5÷36.5	10.7	5.6	14	10
9041508	RFL R U 6-1/8	6	1/8	6	57.3	27.8	36÷41	14.7	6.4	14	11.4
9041509	RFL R U 6-1/4	6	1/4	8	60.3	28.8	36÷41	14.7	6.4	18	11.4
9041510	RFL R U 8-1/8	8	1/8	6	65.3	31.8	44÷49	18.7	9.1	15	13.8
9041511	RFL R U 8-1/4	8	1/4	8	69.7	34.2	44÷49	18.7	9.1	18	13.8
9041512	RFL R U 8-3/8	8	3/8	9	71.3	34.8	44÷49	18.7	9.1	22	13.8

G	H	I	II	Ch	Ch1	Nmax
17.5	M9x0.75	12.8	16	11	9	4
17.5	M9x0.75	12.8	16	11	12	4
20	M12x0.75	14.6	20	15	12	4
20	M12x0.75	14.6	20	15	14	4
26	M15x1	18.7	24	20	14	4.5
26	M15x1	18.7	24	20	14	4.5
26	M15x1	18.7	24	20	17	4.5



RFL R PIPE-PIPE BIDIRECTIONAL

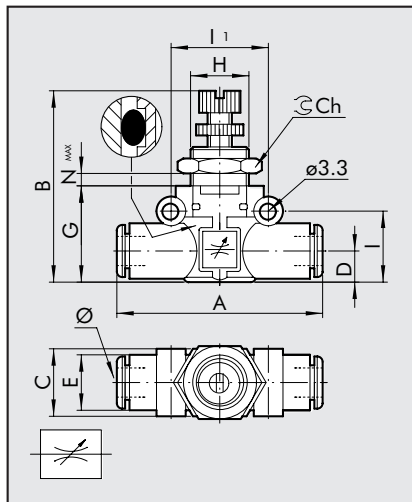

Code	Ref.	Ø	A	B	C	D	E	G	H	I	I1	Ch	Nmax
9041601	RFL R B 4-4	4	40	33.5÷36.5	10.7	5.6	10	17.5	M9x0.75	12.8	16	11	4
9041616	RFL R B 6-6	6	47	36÷41	14.7	6.4	11.4	20	M12x0.75	14.6	20	15	4
9041624	RFL R B 8-8	8	55.5	44÷49	18.7	9.1	13.8	26	M15x1	18.7	24	20	4.5

RFL R THREAD-PIPE BIDIRECTIONAL

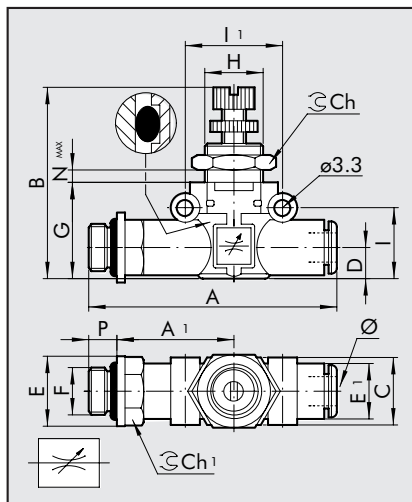

Code	Ref.	F	Ø	P	A	A1	B	C	D	E	E1
9041701	RFL R B M5-4	M5	4	4	46.7	22.7	33.5÷36.5	10.7	5.6	9.9	10
9041702	RFL R B 1/8-4	1/8	4	6	50.6	24.6	33.5÷36.5	10.7	5.6	14	10
9041708	RFL R B 1/8-6	1/8	6	6	57.3	27.8	36÷41	14.7	6.4	14	11.4
9041709	RFL R B 1/4-6	1/4	6	8	60.3	28.8	36÷41	14.7	6.4	18	11.4
9041710	RFL R B 1/8-8	1/8	8	6	65.3	31.8	44÷49	18.7	9.1	15	13.8
9041711	RFL R B 1/4-8	1/4	8	8	69.7	34.2	44÷49	18.7	9.1	18	13.8
9041712	RFL R B 3/8-8	3/8	8	9	71.3	34.8	44÷49	18.7	9.1	22	13.8

G	H	I	I1	Ch	Ch1	Nmax
17.5	M9x0.75	12.8	16	11	9	4
17.5	M9x0.75	12.8	16	11	12	4
20	M12x0.75	14.6	20	15	12	4
20	M12x0.75	14.6	20	15	14	4
26	M15x1	18.7	24	20	14	4.5
26	M15x1	18.7	24	20	14	4.5
26	M15x1	18.7	24	20	17	4.5

NOTES