

- Compact size/low weight/In-line units
- High flow performance
- Suitable for panel and wall mounting
- Two gain flow control
- Adjustment can be locked
- Captive regulator needle will not blow out when unscrewed
- Adjusting knob position line



### Technical Data

**Medium:**

Compressed air, filtered, lubricated or non lubricated, inert gases.

**Operation:**

Uni-directional flow control.

**Mounting:**

In-line. Panel mounted by hexagonal mounting nut. Wall mounted by through-holes in regulator body.

Port size: BSPP and NPT		
M5	T1000M0500	(Not Available)
1/8"	T1000C1800	T1000A1800
1/4"	T1000C2800	T1000A2800
3/8"	T1000C3800	T1000A3800
1/2"	T1000C4800	T1000A4800

**Operating pressure:**

1-10 bar (0,3-10 bar for M5)

**Operating Temperature:**

-20°C to 80°C

Consult our technical service for use below +2°C

### Materials

M5: Aluminium body, Nitrile seals, brass needle internal and external parts.

1/8, 1/4, 3/8, 1/2: Aluminium alloy body, Nitrile seals, brass needle and internal parts, external parts in aluminium alloy.

### Ordering Information

To order, quote product number from table overleaf:

e.g. T1000C1800 for 1/8 BSPP model.

T1000A2800 for 1/4 NPT model.

### Alternative Models:

M/800 range of heavy duty regulators see page 5.9.051.01

M/600 range of heavy duty panel mounting flow regulators.

see page 5.9.041.01

S/518 Precision flow regulator

(air & hydraulic)

see page 5.9.031.01

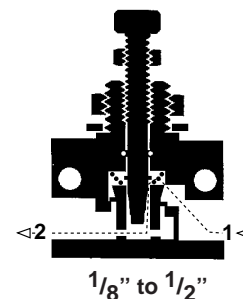
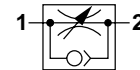



General Information

Port	Maximum Regulating Flow Factor		Critical Pressure Ratio (b)	Free Flow Factor		Critical Pressure Ratio (b)	Minimum Operating Pressure (bar)	Opening Pressure (bar)	Weight (gms)
	BSPP port	NPT port		BSPP port	NPT port				
M5	0,28 0,07		0,2	0,28 0,07		0,2	0,3	0,3	20
1/8	0,57 0,14	0,57 0,14	0,2	1,50 0,37	1,50 0,37	0,2	1,0	<0,1	31
1/4	1,30 0,32	1,30 0,32	0,2	2,80 0,69	2,80 0,69	0,2	1,0	<0,1	56
3/8	4,80 1,17	4,30 1,00	0,2	6,70 1,64	5,90 1,45	0,2	1,0	<0,1	150
1/2	7,50 1,84	6,50 1,60	0,2	8,30 2,00	7,80 1,90	0,2	1,0	<0,1	180

\*C :measured in dm<sup>3</sup>/(s.bar)  
 \*\*Cv :measured in US gal/min

Model T1000M0500

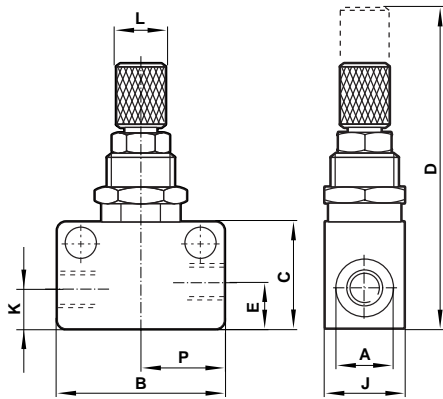

Model	T1000 M0500	T1000 C1800	T1000 A1800	T1000 C2800	T1000 A2800	T1000 C3800	T1000 A3800	T1000 C4800	T1000 A4800
A(mm)	M5	G1/8	1/8NPT	G1/4	1/4NPT	G3/8	3/8NPT	G1/2	1/2NPT
B(mm)	25,0	34,0	34,0	45,0	45,0	58,0	58,0	65,0	65,0
C(mm)	15,0	20,0	20,0	25,4	25,4	32,5	32,5	36,0	36,0
O(mm)	45,0	51,0	51,0	61,5	61,5	78,5	78,5	82,0	82,0
E(mm)	6,5								
F(mm)	12,0	16,5	16,5	20,8	20,8	27,0	27,0	30,5	30,5
Gmm)	18,0	24,0	24,0	32,0	32,0	43,0	43,0	50,0	50,0
H (mm)	4,5	4,5	4,5	4,5	4,5	6,5	6,5	6,5	6,5
J(mm)	12,0	16,0	16,0	19,0	19,0	28,0	28,0	30,0	30,0
K(mm)	5,5	8,0	8,0	9,7	9,7	13,0	13,0	15,0	15,0
L(mm)	M10x0,75	M12x1	M12x1	M14x1	M14x1	M20x1	M20x1	M20x1	M20x1
M(mm)	8a/f	Ø10	Ø10	Ø10	Ø10	14a/f	14a/f	14a/f	14a/f
N(mm)	12a/f	14a/f	14a/f	17a/f	17a/f	24a/f	24a/f	24a/f	24a/f
P(mm)	12,5	17,0	17,0	22,5	22,5	29,0	29,0	32,5	32,5
panel hole	10,5	12,5	12,5	14,5	14,5	20,5	20,5	20,5	20,5
max panel thickness	4,0	4,0	4,0	4,0	4,0	4,0	4,0	4,0	4,0

Model T1000C or T1000A

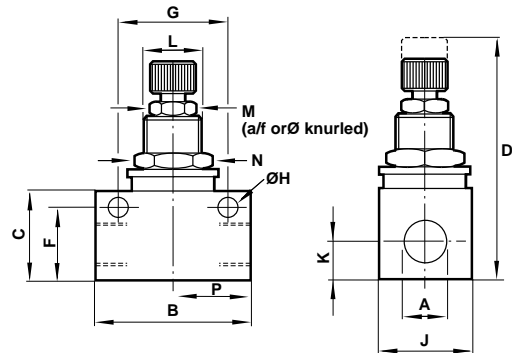

NPT according to ANSI B 1 20 1 G according to BS 2779/ISO 228/1  
 Note: Washer and Nut for Panel Mounting are delivered as standard.



Flow vs Turns at 6 bar (drop pressure = 6 - 0 bar)

**T1000M0500 (M5)**

Flow in dm<sup>3</sup>/s ANR

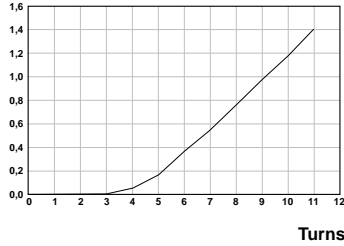

**T1000\*1800 (1/8 BSPP, NPT)**

Flow in dm<sup>3</sup>/s ANR

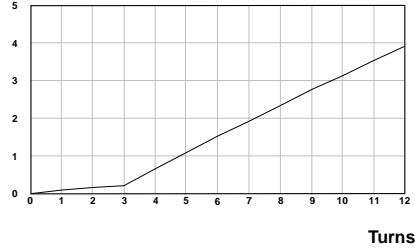

**T1000\*2800 (1/4 BSPP, NPT)**

Flow in dm<sup>3</sup>/s ANR

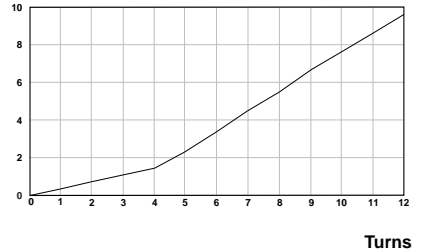

**T1000\*3800 (3/8 port)**

Flow in dm<sup>3</sup>/s ANR

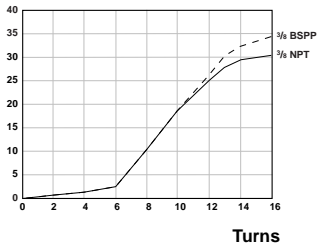

**T1000\*4800 (1/2 port)**

Flow in dm<sup>3</sup>/s ANR

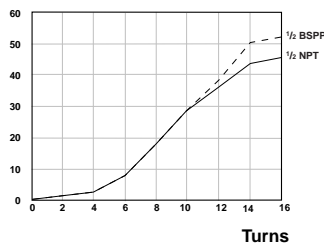

For details of NPT flow factors see General information table above

**Warning**

These products are intended for use in industrial compressed air systems only. Do not use these products where pressures and temperatures can exceed those listed under **Technical Data**.

Before using these products with fluids other than those specified, for non-industrial applications, life-support systems, or other applications not within published specifications, consult NORGREN.

Through misuse, age, or malfunction, components used in fluid power systems can fail in various modes. The system designer is warned to consider the failure modes of all component parts used in fluid power systems and to provide adequate safeguards to prevent personal injury or damage to equipment in the event of such failure.

**System designers must provide a warning to end users in the system instructional manual if protection against a failure mode cannot be adequately provided.**

System designers and end users are cautioned to review specific warnings found in instruction sheets packed and shipped with these products.